

# Stainless Steel Valves



## General Index

Figure No.	Valve Type	Pressure Class	End Connection	Material Available	Size Range	Catalog Page
90	Gate, RS	200 CWP	Threaded	CF3M	½" - 2"	5
190	Gate, NRS	200 CWP	Threaded	CF3M	½" - 2"	5
122	Gate, OS&Y	150	Threaded	CF3M	½" - 2"	6
124	Gate, OS&Y	150	Socket Weld	CF3M	½" - 2"	6
127	Gate, OS&Y	150	Flanged	CF8M	½" - 8"	7
127FF	Gate, OS&Y	150	Flanged	CF8M	½" - 8"	7
2210	Gate, OS&Y	300	Threaded	CF3M	½" - 2"	8
2214	Gate, OS&Y	300	Socket Weld	CF3M	½" - 2"	8
2217	Gate, OS&Y	300	Flanged	CF8M	½" - 10"	9
2217FF	Gate, OS&Y	300	Flanged	CF8M	½" - 10"	9
4210	Gate, OS&Y	600	Threaded	CM3M	½" - 2"	10
4214	Gate, OS&Y	600	Socket Weld	CF3M	½" - 2"	10
40	Globe	200 CWP	Threaded	CF3M	½" - 2"	12
310	Globe	150	Threaded	CF3M	½" - 2"	13
314	Globe	150	Socket Weld	CF3M	½" - 2"	13
317	Globe	150	Flanged	CF8M	½" - 8"	14
317FF	Globe	150	Flanged	CF8M	½" - 8"	14
2310	Globe	300	Threaded	CF3M	½" - 2"	15
2314	Globe	300	Socket Weld	CF3M	½" - 2"	15
2317	Globe	300	Flanged	CF8M	½" - 6"	16
2317FF	Globe	300	Flanged	CF8M	½" - 6"	16
49	Swing Check	200 CWP	Threaded	CF3M	½" - 2"	18
370	Swing Check	150	Threaded	CF3M	½" - 2"	19
374	Swing Check	150	Socket Weld	CF3M	½" - 2"	19
377	Swing Check	150	Flanged	CF8M	½" - 12"	20
377FF	Swing Check	150	Flanged	CF8M	½" - 12"	20
2370	Swing Check	300	Threaded	CF3M	½" - 2"	21
2374	Swing Check	300	Socket Weld	CF3M	½" - 2"	21
2377	Swing Check	300	Flanged	CF8M	½" - 6"	22
2377FF	Swing Check	300	Flanged	CF8M	½" - 6"	22
9502	Ball - 2 pc	2000/1500 CWP	Threaded	CF3M	½" - 2"	24



# Stainless Steel Valves

## How To Order

### How to Specify and Order the Correct Valves

This catalog has been published to assist you in choosing the correct valve for a vast number of piping conditions. The Aloyco product line makes available to you a very broad choice of valves. These valves are described in this catalog.

Care should be taken to select the most suitable valves for your service(s). Exact specification of each valve should be made to avoid possible ambiguity. When requesting quotations and/or ordering the product a fully adequate description should be made.

### Selecting the Valve Size

Nominal size of the pipeline into which the valve will be placed must be determined.

### Valve Material

The following facts should be considered in determining the correct valve material:

- the medium or media which will be controlled
- the temperature range of the line medium (media)
- the pressure range to which the valve will be subjected
- possible atmospheric conditions which may affect the valve
- possible extraordinary stresses to which the valve will be subjected
- safety standards and/or piping codes which must be met

### Type of Valve

What is the control function of the valve? Each valve configuration has been developed to perform certain control functions. Do not expect one type of valve to perform all the valving jobs in a system.

### Pressure-Temperature Ratings

Please pay careful attention that the pressure-temperature ratings of a particular valve are in keeping with the requirements of the service. Pay especially careful attention to the packing and gasket materials as this may limit the rating as is the case with PTFE used as the standard in many of the Aloyco valves.

### Valve and Connections

Considerations as to pipeline integrity, future maintenance, corrosion factors, field assembly, weight and safety should be given in determining the method of connecting the valve in the pipeline.

### Method of Operation

The means by which the valve is operated as supplied are shown for the valves in this catalog. Many optional operating devices are regularly supplied by Aloyco.

### Ordering the Valve

Please state the following information when ordering a valve in order to avoid unnecessary delays and to insure we supply you with the valve you have requested.

1. Valve size
2. Pressure boundary material - metallurgy of the castings and components.
3. Type of valve - gate, globe, check, etc.
4. End connection including wall thickness of connecting pipe if weld end and any special flange facings or finishes
5. Any material deviations from standard - packing, gasket, bolting, etc.
6. Any accessories - acid shield, locking devices, chain operation, etc.
7. Manual or power actuators, please include details of requirements.
8. For convenience in ordering, specify by figure number.

Contact Aloyco for additional assistance in valve selection.

# Stainless Steel Gate Valves



## Materials of Construction

Valve Material Designation	304	316*	Alloy 20	Hastelloy B	Hastelloy C	Monel	Nickel	Inconel	
Part	Component Material								
1 Yoke Nut	303	303	303	303	303	303	303	303	
2 Yoke Nut Set Screw	303	303	303	303	303	303	303	303	
3 Handwheel	Mall. Iron	Mall. Iron	Mall. Iron	Mall. Iron	Mall. Iron	Mall. Iron	Mall. Iron	Mall. Iron	
4 Handwheel Key	Steel	Steel	Steel	Steel	Steel	Steel	Steel	Steel	
5 Grease Fitting	Steel	Steel	Steel	Steel	Steel	Steel	Steel	Steel	
6 Yoke Bushing	303	303	303	303	303	303	303	303	
7 Stem	304	316	A-20	Hastelloy B	Hastelloy C	Monel	Nickel	Inconel	
8 Gland Eyebolt Nut	304	304	304	304	304	304	304	304	
9 Gland Plate	CF-8M	CF-8M	CF-8M	CF-8M	CF-8M	CF-8M	CF-8M	CF-8M	
10 Gland Eyebolt	304	304	304	304	304	304	304	304	
11 Gland Follower	316	316	316	316	316	316	316	316	
12 Gland Bolt Nut	303	303	303	303	303	303	303	303	
13 Gland Bolt	304	304	304	304	304	304	304	304	
14 Packing Ring	PTFE	PTFE	PTFE	PTFE	PTFE	PTFE	PTFE	PTFE	
15 Bonnet	CF-8M	CF-8M	CN-7M	N-12M	CW-12M	M-35	CZ-100	CY-40	
16 Bonnet Bolt	304	304	304	304	304	304	304	304	
17 Gasket	PTFE	PTFE	PTFE	PTFE	PTFE	PTFE	PTFE	PTFE	
18 Bonnet Bolt Nut	303	303	303	303	303	303	303	303	
19 Body	CF-8	CF-8M	CN-7M	N-12M	CW-12M	M-35	CZ-100	CY-40	
20 Wedge	CF-8	CF-8	CF-8	CF-8	CF-8	CF-8	CF-8	CF-8	

### General Notes:

- \* Valve material designation 316 is the Aloyco standard valve
- Body material on threaded & socket weld end is made from low carbon grade castings.
- Valve is regularly supplied with PTFE packing & gasket and suitable for service temperature up to 500°F
- Graphite packing & gaskets are available for higher service temperatures. Consult customer service for material options.

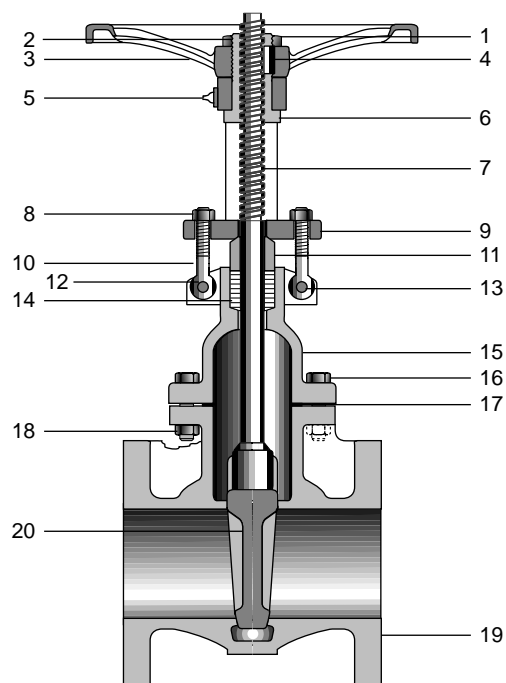

### 200 CWP • Threaded Bonnet • Solid Wedge Disc

#### Materials of Construction

1	Wheel Nut	A194 GR 8F
2	Handwheel	Malleable Iron
3	I.D. Plate	Stainless Steel
4	Packing Nut	A276 Type 316
5	Gland	A276 Type 316
6	Packing	PTFE
7	Bonnet	A351 GR CF8M
8	Stem	A276 Type 316
9	Disc	A351 GR CF8M
10	Body	A351 GR CF8M
11*	Stuffing Box	A276 Type 316

\* Figure 190 only

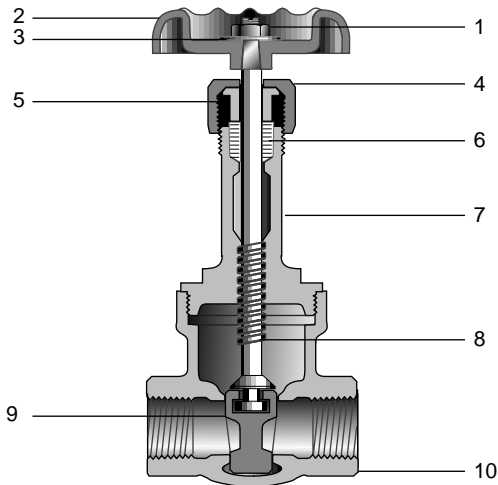

**Fig. 90**

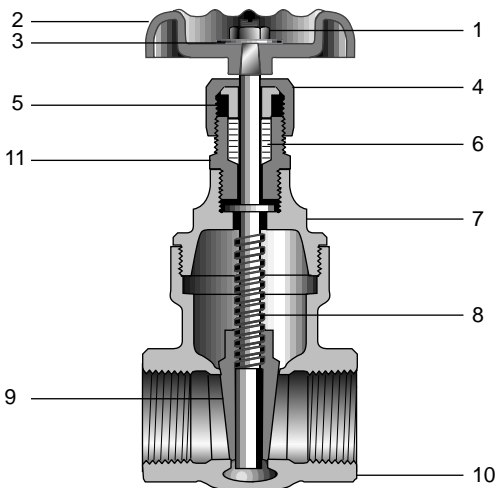

**Fig. 190**

#### Figure 90

Rising Stem

#### Figure 190

Non-Rising Stem

#### Size Range:

1/2 through 2 inches

#### Design Features:

- Threaded Ends
- Integral Seat
- Figure 190 - Inside Screw/Non-rising Stem
- MSS-SP-42

#### Pressure Temperature Ratings:

200 psi @ -20 to 350°F

#### Industry Standards

Threaded Ends	ANSI B.1.20.1
End-to-End	Manufacturer's Standard

#### Dimensions and Weights

Valve Size	Weight		Dimensions			
			A	B		C
	90	190		90	190	
1/2	1.00	0.90	2.12	5.25	3.75	2.06
3/4	1.70	1.50	2.31	6.25	4.56	2.56
1	2.80	2.50	2.81	7.50	5.25	2.75
1 1/2	3.50	3.20	3.56	10.25	7.25	3.62
2	8.00	7.00	3.88	12.25	8.38	4.06

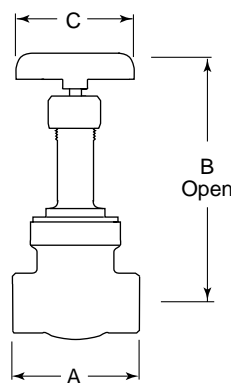

**Fig. 90**

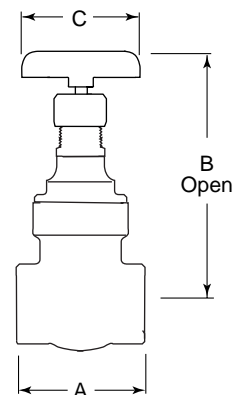

**Fig. 190**

**Class 150 • Outside Screw & Yoke • Solid Wedge Disc**

Figure 122

Threaded Ends

Figure 124

Socket Weld Ends

**Size Range:**

1/2 through 2 inches

**Design Features:**

- Bolted Bonnet
- Rising Stem
- Integral Seat
- Retained Gasket
- MSS-SP-42

**Industry Standards**

Pipe Threads	ANSI B.1.20.1
Wall Section	ANSI B16.34
Socket Weld Ends	ANSI B16.11
End-to-End	Manufacturer's Standard
Pressure-Temp Rating	ANSI B16.34
Testing	API 598

**Dimensions and Weights**

Valve Size	Weight	Dimensions			
		A	B	C	D*
1/2	5.00	3.00	7.25	3.38	.50
3/4	6.00	3.25	7.62	3.38	.50
1	8.00	3.75	8.75	3.88	.50
1 1/2	18.00	4.50	11.25	5.00	.50
2	24.00	5.00	12.88	5.00	.62

\*For Figure 124 only - Socket weld depth

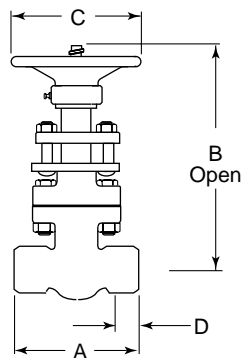

**Materials of Construction**

1	Yoke Bushing Nut	A582 Type 303
2	Yoke Nut Set Screw	A582 Type 303
3	Handwheel	Malleable Iron
4	Grease Fitting	Steel
5	Yoke Bushing	A743 GR CF16F
6	Stem	A276 Type 316
7	Gland Bolt Nut	A194 GR 8F
8	Gland Plate	A351 GR CF8M
9	Gland Follower	A276 Type 316
10	Gland Bolt	A193 GR B8
11	Bonnet Bolt	A194 GR 8F
12	Bonnet	A351 GR CF8M
13	Packing	PTFE
14	Gasket	PTFE
15	Bonnet Bolt Nut	A194 GR 8F
16	Wedge	A351 GR CF8M
17	Body	A351 GR CF8M

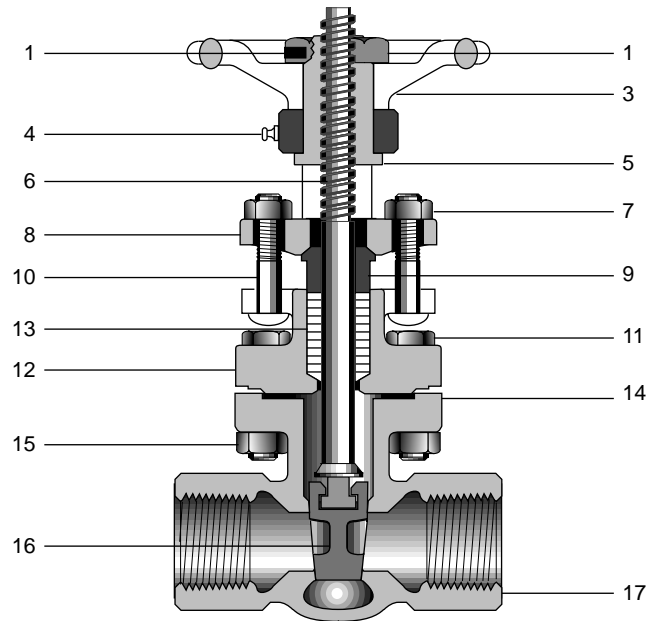

### Class 150 • Outside Screw & Yoke • Solid Wedge Disc

#### Materials of Construction

1	Yoke Bushing Nut	A582 Type 303
2	Yoke Nut Set Screw	A582 Type 303
3	Handwheel	Malleable Iron
4	Grease Fitting	Steel
5	Yoke Bushing	A743 GR CF16F
6	Stem	A276 Type 316
7	Gland Bolt Nut	A194 GR 8F
8	Gland Plate	A351 GR CF8M
9	Gland Follower	A276 Type 316
10	Gland Bolt	A193 GR B8
11	Bonnet Bolt	A194 GR 8F
12	Bonnet	A351 GR CF8M
13	Packing	PTFE
14	Gasket	PTFE
15	Bonnet Bolt Nut	A194 GR 8F
16	Wedge	A351 GR CF8M
17	Body	A351 GR CF8M
18	Yoke Bolt	A193 GR B8
19	Yoke	A351 GR CF8M
20	Yoke Nut	A194 GR 8F

#### Figure 127

Raised Face, Flanged Ends

#### Figure 127FF

Flat Face, Flanged Ends

#### Size Range:

1/2 through 8 inches

#### Design Features:

- Bolted Bonnet
- Rising Stem
- Integral Seat
- Retained Gasket
- MSS-SP-42

#### Industry Standards

End Flanges	ANSI B16.5
Wall Section	ANSI B16.34
Face-to-Face	ANSI B16.10
Pressure-Temp Ratings	ANSI B16.34
Design	API 603
Testing	API 598

#### Dimensions and Weights

Valve Size	Weight	Dimensions			
		A	B	C	D
1/2	7.00	4.25	8.38	3.38	.44
3/4	8.00	4.62	8.75	3.38	.44
1	12.00	5.00	9.00	3.88	.44
1 1/2	22.00	6.50	11.50	5.00	.56
2	33.00	7.00	12.88	5.00	.62
2 1/2	42.00	7.50	15.75	7.00	.96
3	50.00	18.00	17.38	7.50	.75
4	96.00	9.00	22.25	10.00	.94
6	150.00	10.50	29.75	12.00	1.00
8	276.00	11.50	42.00	14.00	1.12

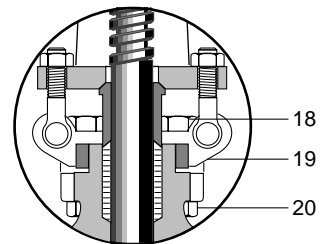
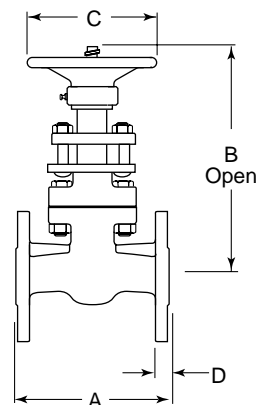
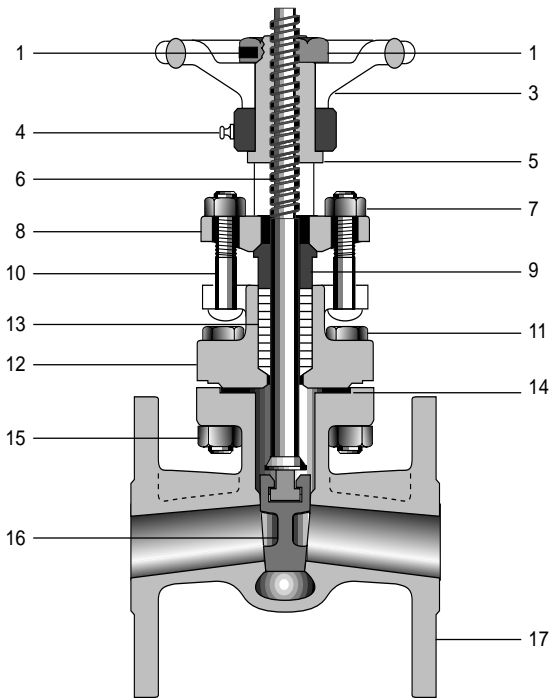

Separate Yoke Detail  
Sizes 2 1/2" - 8"

**Class 300 • Outside Screw & Yoke • Solid Wedge Disc**

**Figure 2210**

Threaded Ends

**Figure 2214**

Socket Weld Ends

**Size Range:**

1/2 through 2 inches

**Design Features:**

- Bolted Bonnet
- Retained Gasket
- Rising Stem
- Integral Seat
- MSS-SP-42

**Industry Standards**

Pipe Threads	ANSI B.1.20.1
Wall Section	ANSI B16.34
Socket Weld Ends	ANSI B16.11
End-to-End	Manufacturer's Standard
Pressure-Temp. Rating	ANSI B16.34
Testing	API 598

**Dimensions and Weights**

Valve Size	Weight	Dimensions			
		A	B	C	D*
1/2	6.10	3.12	7.25	3.38	.50
3/4	8.00	3.25	7.62	3.38	.50
1	11.50	3.88	8.75	3.88	.50
1 1/2	25.00	4.75	11.25	5.00	.50
2	34.00	5.00	12.88	5.00	.62

\*For Figure 2214 only - Socket weld depth

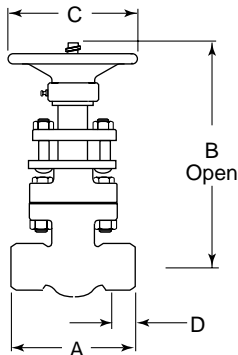

**Materials of Construction**

1	Yoke Bushing Nut	A582 Type 303
2	Yoke Nut Set Screw	A582 Type 303
3	Handwheel	Malleable Iron
4	Grease Fitting	Steel
5	Yoke Bushing	A743 GR CF16F
6	Stem	A276 Type 316
7	Gland Bolt Nut	A194 GR 8F
8	Gland Plate	A351 GR CF8M
9	Gland Follower	A276 Type 316
10	Gland Bolt	A193 GR B8
11	Bonnet Bolt	A194 GR 8F
12	Bonnet	A351 GR CF8M
13	Packing	PTFE
14	Gasket	PTFE
15	Bonnet Bolt Nut	A194 GR 8F
16	Wedge	A351 GR CF8M
17	Body	A351 GR CF8M

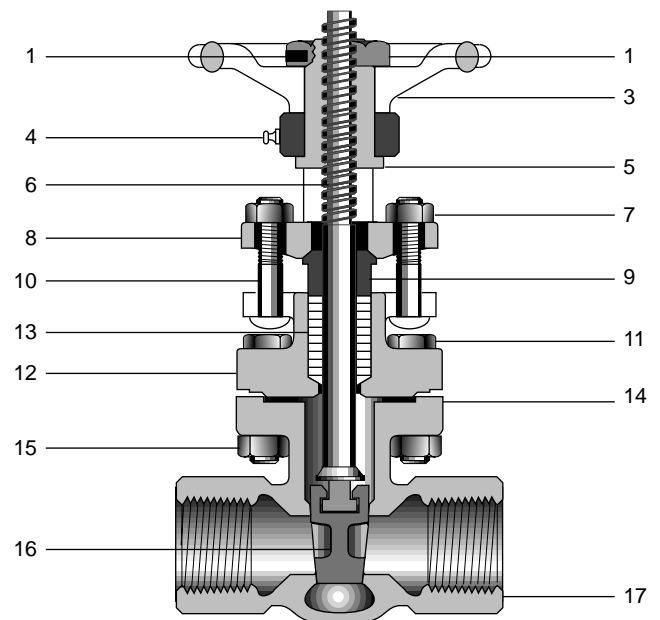

### Class 300 • Outside Screw & Yoke • Solid Wedge Disc

#### Materials of Construction

1	Yoke Bushing Nut	A582 Type 303
2	Handwheel Nut	A582 Type 303
3	Handwheel	Malleable Iron
4	Retainer Set Screw	A582 Type 303
5	Bushing Retainer	A582 Type 303
6	Yoke Bushing	A582 Type 303
7	Grease Fitting	Steel
8	Gland Bolt Nut	A194 GR 8F
9	Gland Plate	A351 GR CF8M
10	Gland Follower	A276 Type 316
11	Gland Bolt	A193 GR B8
12	Packing	PTFE
13	Pipe Plug	A276 Type 316
14	Lantern Ring	A276 Type 316
15	Bonnet	A351 GR CF8M
16	Stem	A276 Type 316
17	Gasket	PTFE
18	Bonnet Bolt Nut	A194 GR 8F
19	Bonnet Bolt	A193 GR B8
20	Body	A351 GR CF8M
21	Wedge	A351 GR CF8M
22	Gland Bolt	A193 GR B8
23	Yoke	A351 GR CF8M
24	Bolt Nut	A194 GR 8F
25	Yoke Bolt	A193 GR B8

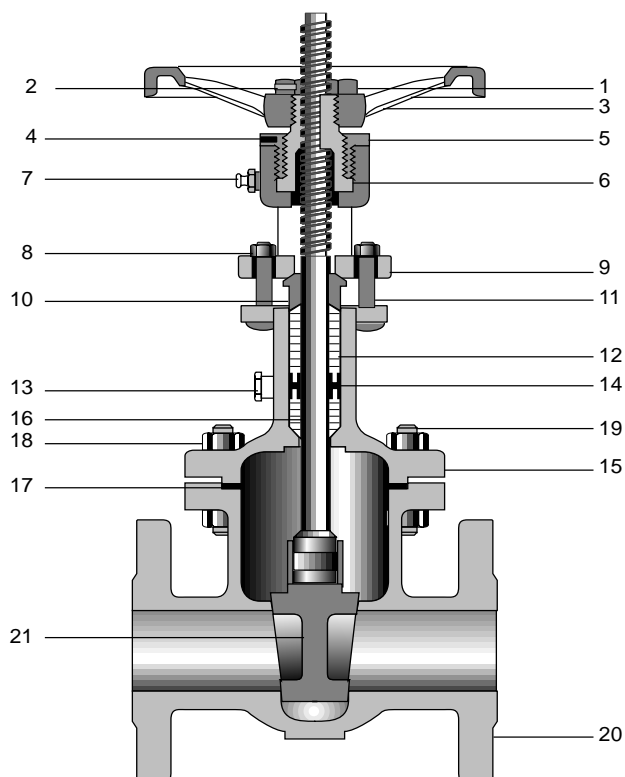

#### Figure 2217

Raised Face, Flanged Ends

#### Figure 2217FF

Flat Face, Flanged Ends

#### Size Range:

1/2 through 10 inches

#### Design Features:

- Bolted Bonnet
- Retained Gasket
- Rising Stem
- Integral Seat
- MSS-SP-42

#### Industry Standards

End Flanges	ANSI B16.5
Wall Section	ANSI B16.34
Face-to-Face	ANSI B16.10
Pressure-Temp. Ratings	ANSI B16.34
Testing	API 598

#### Dimensions and Weights

Valve Size	Weight	Dimensions			
		A	B	C	D
1/2	9.30	5.50	7.25	3.38	.56
3/4	13.20	6.00	7.62	3.38	.62
1	18.40	6.50	8.75	3.88	.96
1 1/2	36.00	7.50	11.25	5.00	.81
2	48.00	8.50	12.88	5.00	.88
3	102.00	11.12	21.31	10.00	1.12
4	169.00	12.00	26.50	12.00	1.25
6	305.00	15.88	35.88	16.00	1.44
8	483.00	16.50	46.25	18.00	1.62
10	890.00	18.00	56.38	20.00	1.88

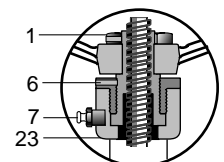
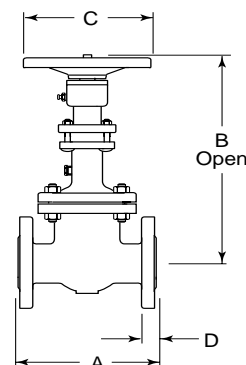

Yoke Bushing Detail  
Sizes 6" to 10"

## Class 600 • Outside Screw & Yoke • Solid Wedge Disc

### Figure 4210

Threaded Ends

### Figure 4214

Socket Weld Ends

#### Size Range:

1/2 through 2 inches

#### Design Features:

- Bolted Bonnet
- Retained Gasket
- Rising Stem
- Integral Seat

#### Industry Standards

Pipe Threads	ANSI B1.20.1
Wall Section	ANSI B16.34
Socket Weld Ends	ANSI B16.11
End-to-End	Manufacturer's Standards
Pressure-Temp Rating	ANSI B16.34
Testing	API 598

#### Dimensions and Weights

Valve Size	Weight	Dimensions			
		A	B	C	D*
1/2	6.80	3.12	7.50	3.50	.50
3/4	8.30	3.25	8.38	4.00	.50
1	14.00	3.88	10.50	5.00	.50
1 1/2	29.00	4.75	13.62	8.00	.50
2	42.00	5.00	15.75	9.00	.62

\*For Figure 4214 only - Socket weld depth

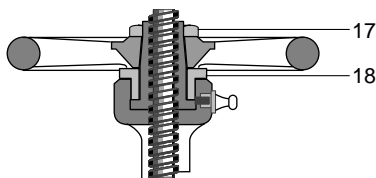
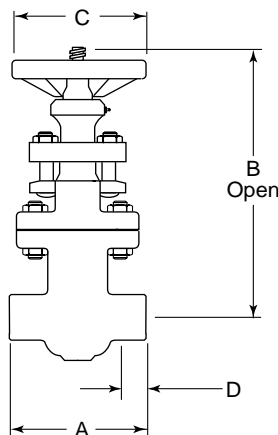
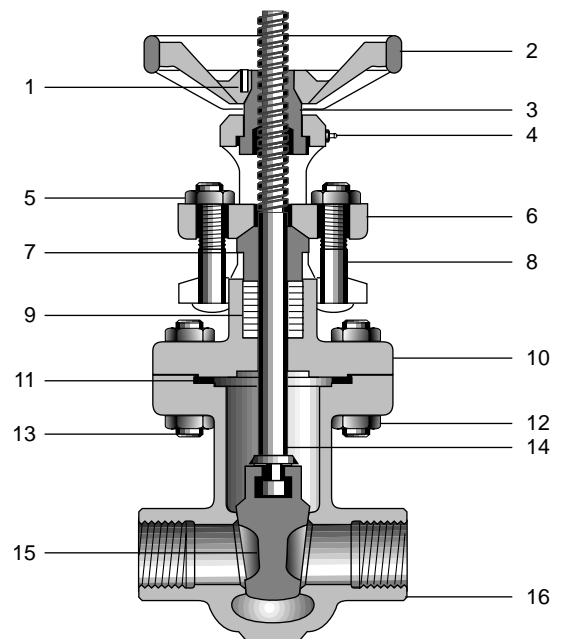

Fig. 4210 & Fig. 4214  
Sizes 1 1/2" - 2"



#### Materials of Construction

1	Yoke Bushing Pin	A582 Type 303
2	Handwheel	Malleable Iron
3	Yoke Bushing	A743 GR CF16F
4	Grease Fitting	Steel
5	Gland Bolt Nut	A194 GR 8F
6	Gland Plate	A351 GR CF8M
7	Gland Follower	A276 Type 316
8	Gland Eyebolt	A193 GR B8
9	Packing	PTFE
10	Bonnet	A351 GR CF8M
11	Gasket	PTFE
12	Bonnet Bolt Nut	A194 GR 8F
13	Bonnet Bolt	A193 GR B8
14	Stem	A276 Type 316
15	Wedge	A351 GR CF8M
16	Body	A351 GR CF8M
17	Handwheel Nut	A582 Type 303
18	Yoke Bushing Retainer	A582 Type 303





# Stainless Steel Globe Valves

## Materials of Construction

Valve Material Designation	304	316*	Alloy 20	Hastelloy B	Hastelloy C	Monel	Nickel	Inconel	
Part	Component Material								
1 Handwheel	Mall. Iron	Mall. Iron	Mall. Iron	Mall. Iron	Mall. Iron	Mall. Iron	Mall. Iron	Mall. Iron	Mall. Iron
2 Handwheel Nut	303	303	303	303	303	303	303	303	303
3 Yoke Nut Pin	Steel	Steel	Steel	Steel	Steel	Steel	Steel	Steel	Steel
4 Yoke	CF-8M	CF-8M	CF-8M	CF-8M	CF-8M	CF-8M	CF-8M	CF-8M	CF-8M
5 Yoke Bushing Nut	303	303	303	303	303	303	303	303	303
6 Yoke Bushing	—	—	—	—	—	—	—	—	—
7 Gland Bolt Nut	303	303	303	303	303	303	303	303	303
8 Gland Plate	CF-8M	CF-8M	CF-8M	CF-8M	CF-8M	CF-8M	CF-8M	CF-8M	CF-8M
9 Gland Follower	316	316	316	316	316	316	316	316	316
10 Gland Bolt	304	304	304	304	304	304	304	304	304
11 Packing	PTFE	PTFE	PTFE	PTFE	PTFE	PTFE	PTFE	PTFE	PTFE
12 Bonnet Bolt	304	304	304	304	304	304	304	304	304
13 Bonnet	CF-8	CF-8M	CN-7M	N-12M	CW-12M	M-35	CZ-100	CY-40	
14 Gasket	PTFE	PTFE	PTFE	PTFE	PTFE	PTFE	PTFE	PTFE	PTFE
15 Bonnet Bolt Nut	303	303	303	303	303	303	303	303	303
16 Stem	304	316	A-20	Hastelloy B	Hastelloy C	Monel	Nickel	Inconel	
17 Swivel Nut	CF-8	CF-8M	CN-7M	N-12M	CW-12M	M-35	CZ-100	CY-40	
18 Swivel Nut Pin	304	316	A-20	Hastelloy B	Hastelloy C	Monel	Nickel	Inconel	
19 Disc	CF-8	CF-8M	CN-7M	N-12M	CW-12M	M-35	CZ-100	CY-40	
20 Body	CF-8	CF-8M	CN-7M	N-12M	CW-12M	M-35	CZ-100	CY-40	

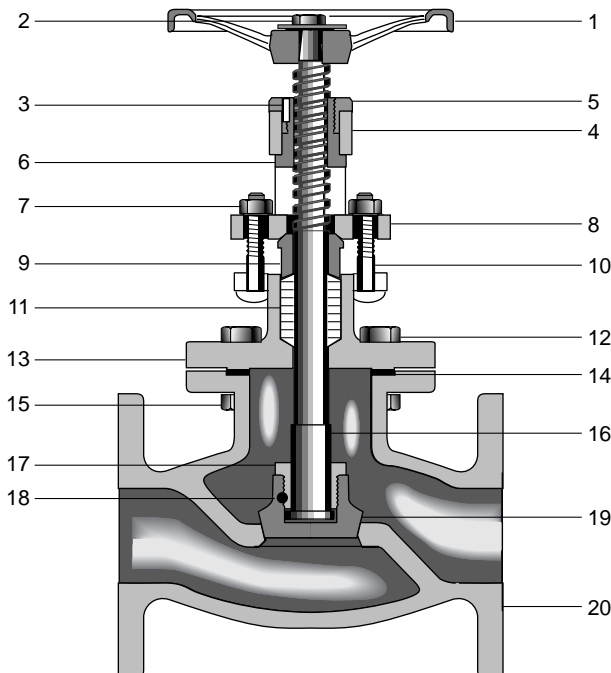

### General Notes:

- \* Valve material designation 316 is the Aloyco standard valve
- Body material on threaded & socket weld end is made from low carbon grade castings.
- Valve is regularly supplied with PTFE packing & gasket and suitable for service temperature up to 500°F
- Graphite packing & gaskets are available for higher service temperatures. Consult factory or customer service for material options.

**200 CWP • Union Bonnet • Plug Type Disc**

Figure 40  
Threaded Ends

**Size Range:**

1/2 through 2 inches

**Design Features:**

- Inside Screw
- Rising Stem
- Integral Seat

**Pressure Temperature Ratings:**

200 psi @ -20° to 100°F  
135 psi @ -500°F max.

**Materials of Construction**

1	Handwheel Nut	A194 GR 8F
2	Handwheel	Malleable Iron
3	Stem	A276 Type 316
4	Gland	A276 Type 316
5	Packing Nut	A276 Type 316
6	Packing	PTFE
7	Bonnet	A351 GR CF8M
8	Gasket	PTFE
9	Union Ring	A276 Type 316
10	Swivel Nut	A276 Type 316
11	Disc	A351 GR CF8M
12	Body	A351 GR CF8M

**Industry Standards**

Threaded Ends	ANSI B1.20.1
End-to-End	Manufacturer's Standard

**Dimensions and Weights**

Valve Size	Weight	Dimensions		
		A	B	C
1/2	1.30	2.25	4.18	3.75
3/4	2.00	2.75	5.00	3.75
1	3.00	3.31	5.62	4.75
1 1/2	6.50	4.50	7.44	6.00
2	10.0	5.25	8.25	7.00

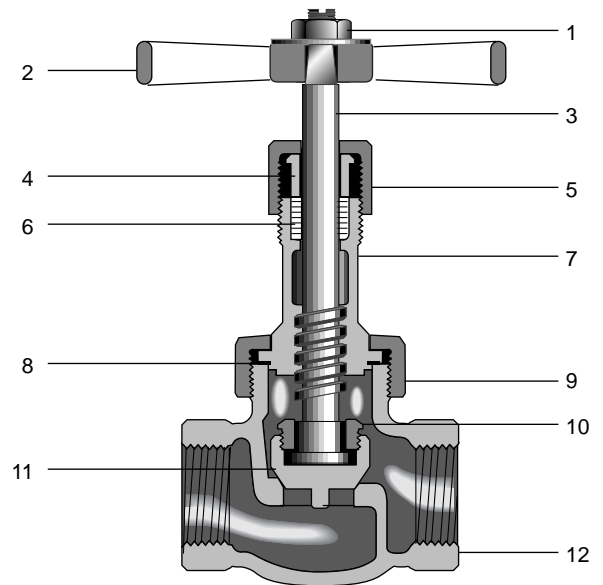
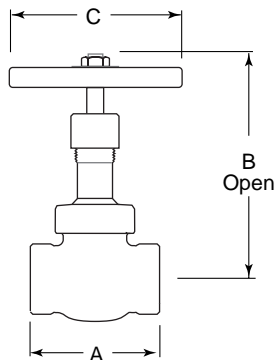

### Class 150 • Outside Screw & Yoke • Plug Type Disc

#### Materials of Construction

1	Handwheel Nut	A582 Type 303
2	Handwheel	Malleable Iron
3	Yoke Nut Pin	A582 Type 303
4	Yoke Bushing Nut	A582 Type 303
5	Yoke Bushing	A582 Type 303
6	Gland Bolt Nut	A194 GR 8F
7	Gland Plate	A351 GR CF8M
8	Gland Follower	A351 GR CF8M
9	Gland Bolt	A193 GR B8
10	Packing	PTFE
11	Bonnet Bolt	A193 GR B8
12	Bonnet	A351 GR CF8M
13	Gasket	PTFE
14	Bonnet Bolt Nut	A194 GR 8F
15	Stem	A276 Type 316
16	Swivel Nut	A351 GR CF8M
17	Swivel Nut Pin	A276 Type 316
18	Disc	A351 GR CF8M
19	Body	A351 GR CF8M
20	Yoke	A351 GR CF8M
21	Yoke Bolt	A193 GR 8F
22	Yoke Bolt Nut	A194 GR 8F

#### Figure 310

Threaded Ends

#### Figure 314

Socket Weld Ends

#### Size Range:

1/2 through 2 inches

#### Design Features:

- Bolted Bonnet
- Retained Gasket
- Rising Stem
- Integral Seat
- MSS-SP-40

#### Industry Standards

Pipe Threads	ANSI B1.20.1
Wall Section	ANSI B16.34
Socket Weld Ends	ANSI B16.11
End-to-End	Manufacturer's Standard
Pressure-Temp. Ratings	ANSI B16.34
Testing	API 598

#### Dimensions and Weights

Valve Size	Weight	Dimensions			
		A	B	C	D*
1/2	4.50	3.38	6.50	3.00	.38
3/4	6.00	3.75	8.00	3.50	.50
1	7.00	4.25	8.38	3.50	.50
1 1/2	15.00	5.50	10.25	5.00	.50
2	23.00	6.50	12.00	6.00	.31

\* For Figure 314 only - socket weld depth

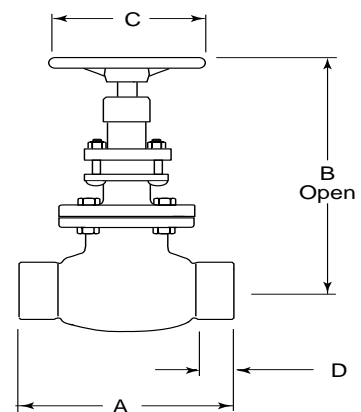
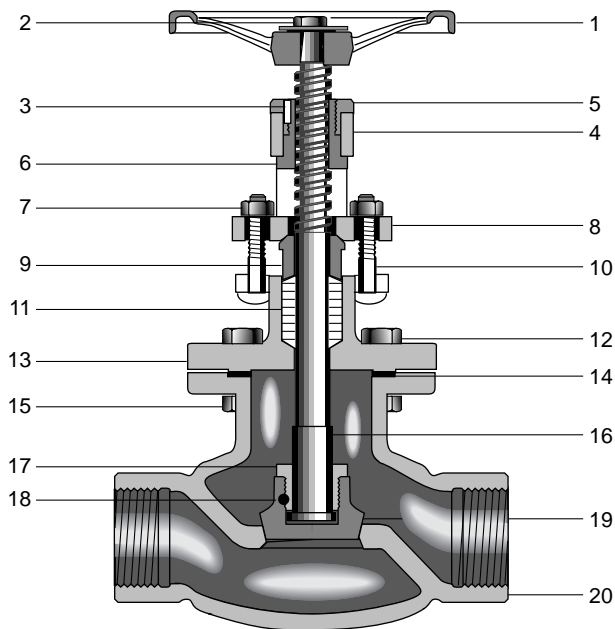

# Figures 317 317 FF

# Stainless Steel Globe Valves



## Class 150 • Outside Screw & Yoke • Plug Type Disc

**Figure 317**  
Raised Face, Flanged Ends

**Figure 317FF**  
Flat Face, Flanged Ends

**Size Range:**  
1/2 through 8 inches

- Design Features:**
- Bolted Bonnet
  - Rising Stem
  - Retained Gasket
  - Integral Seat
  - Disc Guide Below Seat
  - MSS-SP-42

### Industry Standards

End Flanges	ANSI B16.5
Wall Section	ANSI B16.34
Face-to-Face	ANSI B16.10
Pressure-Temp. Ratings	ANSI B16.34
Testing	API 598

### Materials of Construction

1	Handwheel Nut	A582 Type 303
2	Handwheel	Malleable Iron
3	Yoke Nut Pin	A582 Type 303
4	Yoke Bushing Nut	A582 Type 303
5	Yoke Bushing	A582 Type 303
6	Gland Bolt Nut	A194 GR 8F
7	Gland Plate	A351 GR CF8M
8	Gland Follower	A351 GR CF8M
9	Gland Bolt	A193 GR B8
10	Packing	PTFE
11	Bonnet Bolt	A193 GR B8
12	Bonnet	A351 GR CF8M
13	Gasket	PTFE
14	Bonnet Bolt Nut	A194 GR 8F
15	Stem	A276 Type 316
16	Swivel Nut	A351 GR CF8M
17	Swivel Nut Pin	A276 Type 316
18	Disc	A351 GR CF8M
19	Body	A351 GR CF8M
20	Yoke	A351 GR CF8M
21	Yoke Bolt	A193 GR 8F
22	Yoke Bolt Nut	A194 GR 8F

### Dimensions and Weights

Valve Size	Weight	Dimensions		
		A	B	C
1/2	6.50	4.25	6.50	3.00
3/4	8.00	4.62	8.00	3.50
1	10.00	5.00	8.38	3.50
1 1/2	19.00	6.50	10.25	5.00
2	31.00	8.00	12.00	6.00
3	58.00	9.50	14.50	8.00
4	95.00	11.50	17.00	10.00
6	173.00	16.00	21.38	12.00
8	284.00	19.50	26.00	16.00

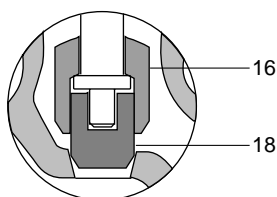

Disc Detail  
Sizes 1/2" to 2"

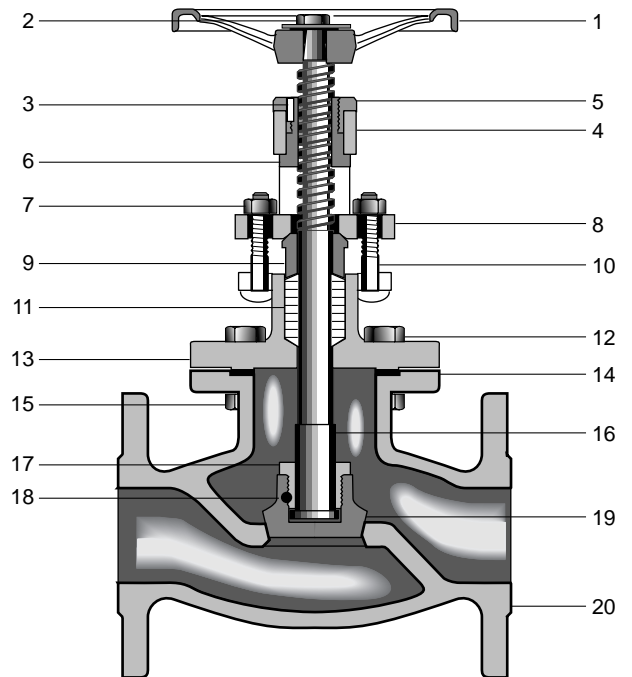
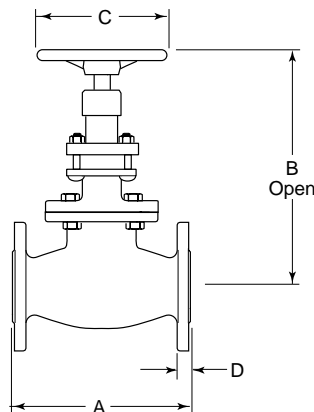



# Stainless Steel Globe Valves

Figures 2310  
2314

## Class 300 • Outside Screw & Yoke • Plug Type Disc

### Materials of Construction

1	Handwheel Nut	A582 Type 303
2	Handwheel	Malleable Iron
3	Yoke Bushing	A582 Type 303
4	Stem	A276 Type 316
5	Gland Bolt Nut	A194 GR 8F
6	Gland Plate	A351 GR CF8M
7	Gland Bolt	A193 GR B8
8	Gland Follower	A276 Type 316
9	Packing	PTFE
10	Bonnet Bolt Nut	A194 GR 8F
11	Bonnet	A351 GR CF8M
12	Gasket	PTFE
13	Bonnet Bolt	A193 GR B8
14	Swivel Nut	A276 Type 316
15	Body	A351 GR CF8M
16	Disc	A351 GR CF8M
17	Swivel Nut Pin	A276 Type 316

### Figure 2310

Threaded Ends

### Figure 2314

Socket Weld Ends

#### Size Range:

1/2 through 2 inches

#### Design Features:

- Bolted Bonnet
- Rising Stem
- Retained Gasket
- Integral Seat
- Disc Guide Below Seat
- MSS-SP-42

### Industry Standards

Pipe Threads	ANSI B1.20.1
Wall Section	ANSI B16.34
Face-to-Face	Manufacturer's Standard
Pressure-Temp. Ratings	ANSI B16.34
Testing	API 598

### Dimensions and Weights

Valve Size	Weight	Dimensions			
		A	B	C	D*
1/2	5.00	3.62	6.50	3.00	.38
3/4	6.00	4.00	8.00	3.50	.50
1	7.00	4.50	8.38	3.50	.50
1 1/2	15.00	5.75	10.25	5.00	.50
2	24.00	6.75	12.00	6.00	.62

\* For Figure 2314 only - socket weld depth

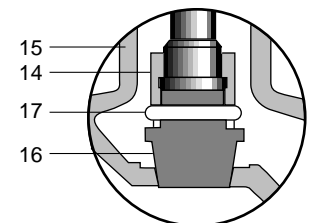
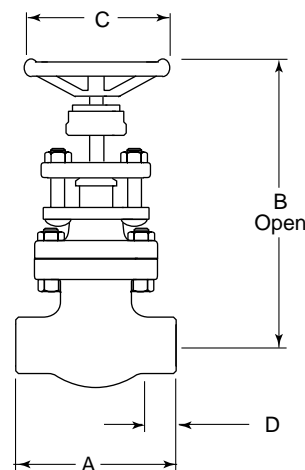
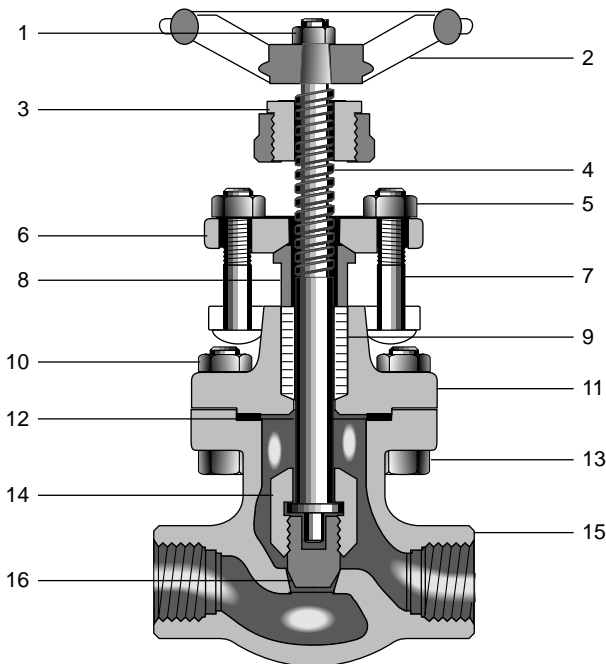

Disc Detail  
Sizes 1/2" to 1"

# Figures 2317A 2317FF Stainless Steel Globe Valves



## Class 300 • Outside Screw & Yoke • Plug Type Disc

**Figure 2317A**  
Raised Face, Flanged Ends  
**Figure 2317FF**  
Flat Face, Flanged Ends

**Size Range:**  
1/2 through 6 inches

- Design Features:**
- Bolted Bonnet
  - Retained Gasket
  - Rising Stem
  - Integral Seat
  - MSS-SP-42

### Industry Standards

End Flanges	ANSI B16.5
Wall Section	ANSI B16.34
Face-to-Face	ANSI B16.10
Pressure-Temp. Ratings	ANSI B16.34
Testing	API 598

### Materials of Construction

1	Handwheel Nut	A582 Type 303
2	Handwheel	Malleable Iron
3	Yoke Nut Pin	A582 Type 303
4	Yoke Bushing Nut	A743 GR CF-16F
5	Yoke Bushing	A743 GR CF-16F
6	Stem	A276 Type 316
7	Gland Bolt Nut	A194 GR 8F
8	Gland Plate	A351 GR CF8M
9	Gland Follower	A276 Type 316
10	Gland Bolt	A193 GR B8
11	Packing	PTFE
12	Lantern Ring	A276 Type 316
13	Pipe Plug	A276 Type 316
14	Gasket	PTFE
15	Bonnet Bolt Nut	A194 GR 8F
16	Bonnet Bolt	A193 GR B8
17	Swivel Nut	A351 GR CF8M
18	Swivel Nut Pin	A276 Type 316
19	Body	A351 GR CF8M
20	Disc	A351 GR CF8M

### Dimensions and Weights

Valve Size	Weight	Dimensions			
		A	B	C	D
1/2	13.00	6.00	9.12	4.00	.56
3/4	17.00	7.00	9.12	4.00	.62
1	24.50	8.00	10.12	6.00	.69
1 1/2	36.00	9.00	13.75	7.00	.18
2	54.00	10.50	15.25	9.00	.88
4	147.00	14.00	22.75	12.00	1.25
6	280.00	17.50	27.88	16.00	1.44

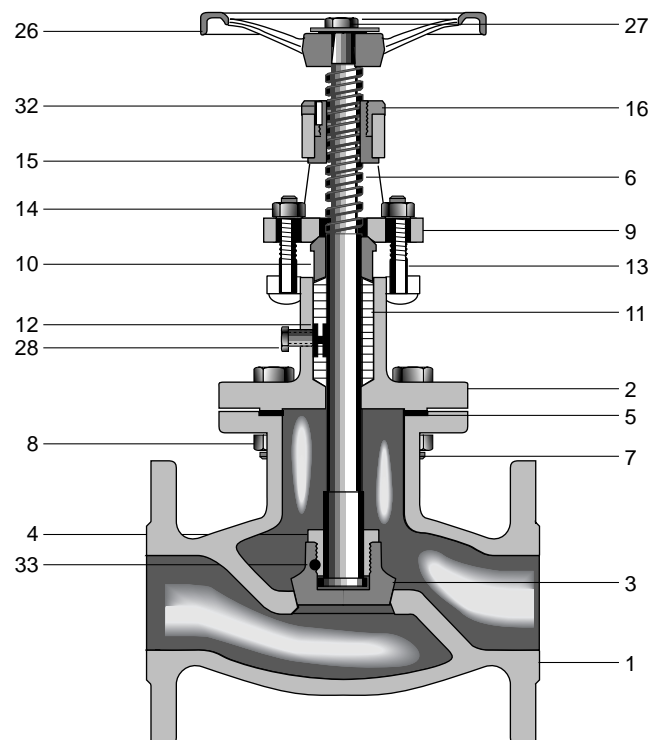
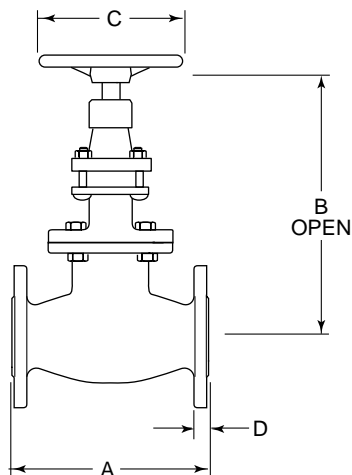



# Stainless Steel Check Valves

## Materials of Construction

Valve Material Designation		304	316*	Alloy 20	Hastelloy B	Hastelloy C	Monel	Nickel	Inconel
Part		Component Material							
1	Cover	CF-8	CF-8M	CN-7M	N-12M	CW-12M	M-35	CZ-100	CY-40
2	Cover Bolt	304	304	304	304	304	304	304	304
3	Cover Pin	Steel	Steel	Steel	Steel	Steel	Steel	Steel	Steel
4	Gasket	PTFE	PTFE	PTFE	PTFE	PTFE	PTFE	PTFE	PTFE
5	Cover Bolt Nut	303	303	303	303	303	303	303	303
6	Clapper Arm Shaft	304	316	A-20	Hastelloy B	Hastelloy C	Monel	Nickel	Inconel
7	Clapper Arm	CF-8	CF-8M	CN-7M	N-12M	CW-12M	M-35	CZ-100	CY-40
8	Disc Nut Washer	304	316	A-20	Hastelloy B	Hastelloy C	Monel	Nickel	Inconel
9	Disc Nut Pin	304	316	A-20	Hastelloy B	Hastelloy C	Monel	Nickel	Inconel
10	Disc Nut	304	316	A-20	Hastelloy B	Hastelloy C	Monel	Nickel	Inconel
11	Disc	CF-8	CF-8M	CN-7M	N-12M	CW-12M	M-35	CZ-100	CY-40
12	Body	CF-8	CF-8M	CN-7M	N-12M	CW-12M	M-35	CZ-100	CY-40

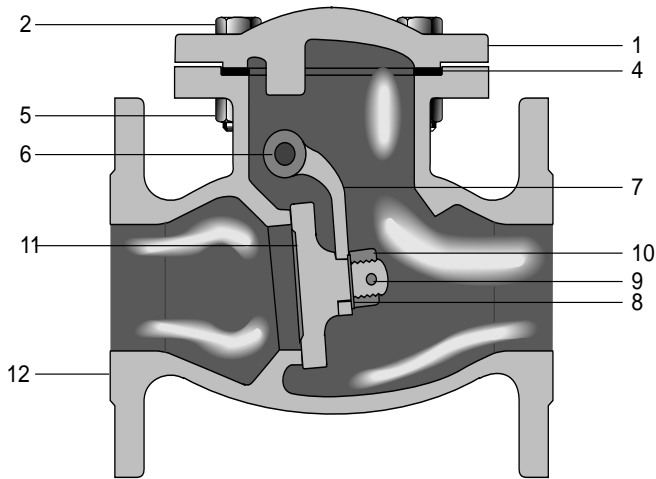

### General Notes:

- \* Valve material designation 316 is the Aloyco standard valve
- Body material on threaded & socket weld end is made from low carbon grade castings.
- Valve is regularly supplied with PTFE gasket and suitable for service temperature up to 500°F
- Graphite gaskets are available for higher service temperatures. Consult factory or customer service for material options.

Figure 49

# Stainless Steel Check Valves



**Class 200 • Y-Pattern • Threaded Cap**

Figure 49  
Threaded Ends

**Size Range:**

1/2 through 2 inches

**Design Features:**

- Integral Seat

**Pressure Temperature Ratings:**

- 200 psi @ -20°F to 100°F
- 135 psi @ 500°F Max

**Materials of Construction**

1	Cap	A351 GR CF8M
2	Gasket	PTFE
3	Disc Lock Nut	A194 GR 8M
4	Hinge	A351 GR CF8M
5	Pipe Plug	A193 GR B8M
6	Hinge Pin	A276 Type 316
7	Disc	A276 Type 316
8	Body	A351 GR CF8M

**Industry Standards**

Pipe Threads	ANSI B1.20.1
--------------	--------------

**Dimensions and Weights**

Valve Size	Weight	Dimensions			
		A	B	C	D
1/2	1.00	3.00	.50	.75	1.88
3/4	1.60	3.50	.75	1.00	2.12
1	2.90	4.25	1.00	1.25	2.75
1 1/2	6.10	5.50	1.50	1.62	3.50
2	9.00	6.50	2.00	2.00	4.25

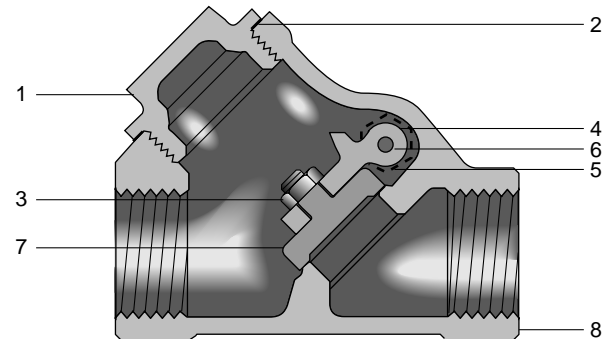
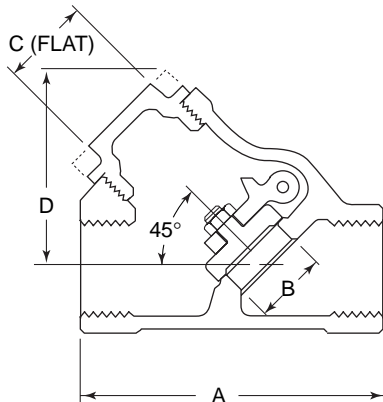



# Stainless Steel Check Valves

Figures 370  
374

## Class 150 • Bolted Cover

### Materials of Construction

1	Cover	A351 GR CF8M
2	Cover Bolt Nut	A194 GR 8F
3	Cover Bolt	A193 GR B8
4	Clapper Arm Shaft	A276 Type 316
5	Disc	A351 GR CF8M
6	Clapper Arm	A351 GR CF8M
7	Disc Nut	A194 GR 8M
8	Disc Nut Pin	A276 Type 316
9	Gasket	PTFE
10	Body	A351 GR CF8M
11	Disc Nut Washer	A276 Type 316

### Figure 370

Threaded Ends

### Figure 374

Socket Weld Ends

### Size Range:

1/2 through 2 inches

### Design Features:

- Retained Gasket
- Integral Seat

### Industry Standards

Pipe Threads	ANSI B2.1
Wall Section	ANSI B16.34
Face-to-Face	ANSI B16.10
End-to-End	Manufacturer's Standard
Pressure Temp. Ratings	ANSI B16.34
Testing	API 598

### Dimensions and Weights

Valve Size	Weight	Dimensions		
		A	B	C*
1/2	4.50	3.75	2.75	.38
3/4	4.50	3.75	3.00	.50
1	7.00	5.00	3.38	.50
1 1/2	11.50	6.00	4.00	.50
2	16.50	6.50	4.50	.62

\* For Figure 374 only - socket weld depth

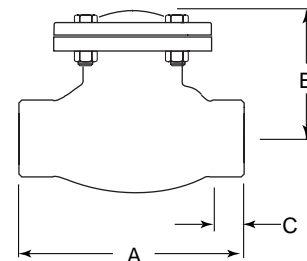
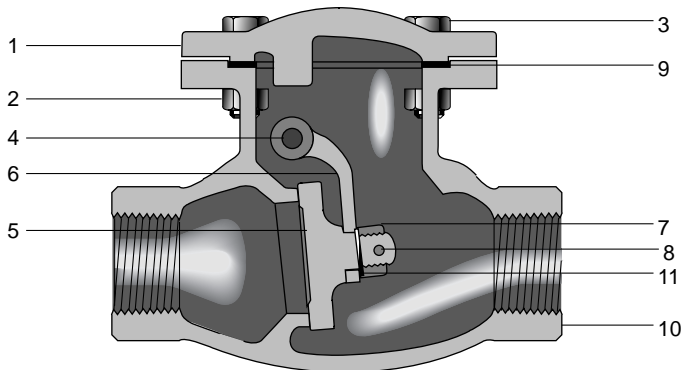

**Class 150 • Bolted Cover**

**Figure 377**  
Raised Face, Flanged Ends

**Figure 377FF**  
Flat Face, Flanged Ends

**Size Range:**  
1/2 through 12 inches

- Design Features:**
- Retained Gasket
  - Integral Seat
  - MSS-SP-42

### Materials of Construction

1	Cover	A351 GR CF8M
2	Cover Bolt Nut	A194 GR 8F
3	Cover Bolt	A193 GR B8
4	Clapper Arm Shaft	A276 Type 316
5	Disc	A351 GR CF8M
6	Clapper Arm	A351 GR CF8M
7	Disc Nut	A194 GR 8M
8	Disc Nut Pin	A276 Type 316
9	Gasket	PTFE
10	Body	A351 GR CF8M
11	Disc Nut Washer	A276 Type 316

### Industry Standards

End Flanges	ANSI B16.5
Wall Section	ANSI B16.34
Face-to-Face	ANSI B16.10
Pressure-Temp. Ratings	ANSI B16.34
Testing	API 598

### Dimensions and Weights

Valve Size	Weight	Dimensions		
		A	B	C
1/2	5.00	4.25	2.75	.44
3/4	6.00	4.31	3.00	.44
1	10.00	5.00	3.38	.44
1 1/2	17.00	6.50	4.00	.56
2	26.00	8.00	4.50	.62
3	52.00	9.50	5.62	.75
4	76.00	11.50	6.75	.94
6	145.00	14.00	8.00	1.00
8	260.00	19.50	10.00	1.12
10	380.00	24.50	13.12	1.18
12	435.00	27.50	14.88	1.25

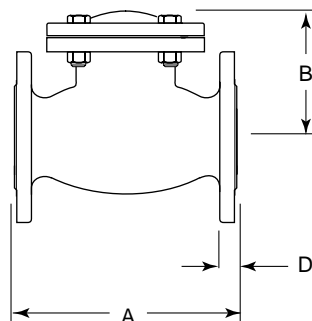
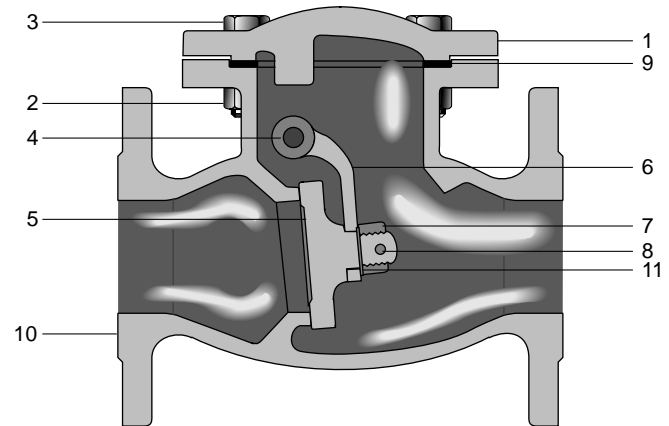



# Stainless Steel Check Valves

Figures 2370  
2374

## Class 300 • Bolted Cover

### Materials of Construction

1	Cover Bolt	A193 GR B8
2	Cover Bolt Nut	A194 GR 8F
3	Cover	A351 GR CF8M
4	Gasket	PTFE
5	Clapper Arm Shaft	A276 Type 316
6	Clapper Arm	A351 GR CF8M
7	Body	A351 GR CF8M
8	Disc	A276 Type 316
9	Disc Nut Washer	A276 Type 316
10	Disc Nut Pin	A276 Type 316
11	Disc Nut	A194 GR 8M

Figure 2370  
Threaded Ends

Figure 2374  
Socket Weld Ends

**Size Range:**  
1/2 through 2 inches

**Design Features:**

- Retained Gasket
- Integral Seat

### Industry Standards

Pipe Threads	ANSI B1.20.1
Wall Section	ANSI B16.34
Face-to-Face	ANSI B16.10
End-to-End	Manufacturer's Standard
Pressure Temp. Ratings	ANSI B16.34
Testing	API 598

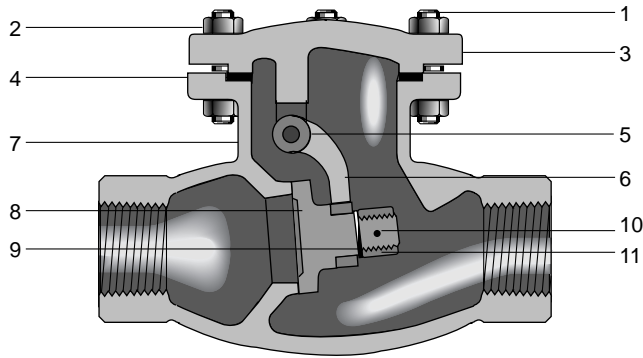

### Dimensions and Weights

Valve Size	Weight	Dimensions		
		A	B	C*
1/2	7.00	4.50	4.75	.38
3/4	10.00	5.00	5.25	.50
1	14.00	5.50	5.25	.50
1 1/2	20.00	6.00	5.25	.50
2	29.00	6.50	5.50	.62

\* For Figure 2374 only - socket weld depth

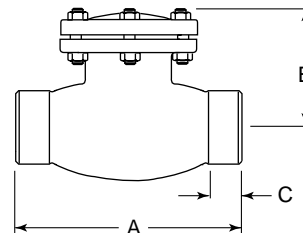

**Class 300 • Bolted Cover**

**Figure 2377**  
Raised Face, Flanged Ends  
**Figure 2377FF**  
Flat Face, Flanged Ends

**Size Range:**  
1/2 through 12 inches

- Design Features:**
- Retained Gasket
  - Integral Seat
  - MSS-SP-42

### Materials of Construction

1	Cover Bolt	A193 GR B8
2	Cover Bolt Nut	A194 GR 8F
3	Cover	A351 GR CF8M
4	Gasket	PTFE
5	Clapper Arm Shaft	A276 Type 316
6	Clapper Arm	A351 GR CF8M
7	Body	A351 GR CF8M
8	Disc	A276 Type 316
9	Disc Nut Washer	A276 Type 316
10	Disc Nut Pin	A276 Type 316
11	Disc Nut	A194 GR 8M

### Industry Standards

End Flanges	ANSI B16.5
Wall Section	ANSI B16.34
Face-to-Face	ANSI B16.10
Pressure-Temp. Ratings	ANSI B16.34
Testing	API 598

### Dimensions and Weights

Valve Size	Weight	Dimensions		
		A	B	C
1/2	12.00	6.00	4.75	.56
3/4	16.00	7.00	5.25	.62
1	21.00	8.50	5.50	.69
1 1/2	30.00	9.50	5.00	.81
2	40.00	10.50	5.50	.88
3	78.00	12.50	6.75	1.12
4	122.00	14.00	8.00	1.25
6	230.00	17.50	9.50	1.44
8	362.00	21.00	12.25	1.62
10	575.00	24.50	14.00	1.88
12	688.00	28.00	16.50	2.00

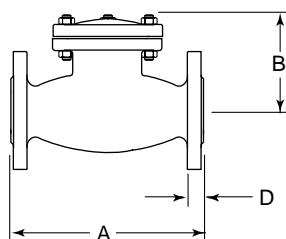
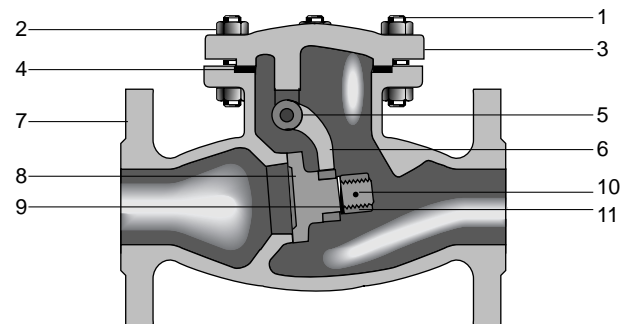



# Stainless Steel Ball Valves

Figure 9502

## 2000/1500 CWP • Two-Piece Body

### Materials of Construction

1	Follower	Type 316 GR CF8M, A-351
2	Stem	Type 316, A-276
3	Handle Nut	Stainless Steel 304, A-270
4	Handle Sleeve	Vinyl
5	Handle	Type 304, A-276
6	Gland	Type 316, A276
7	Packing	PTFE
8	Thrust Washer	PTFE
9	Seat	PTFE 15% Glass Filled
10	Ball	Type 316, A-276
11	Body	Type 316 GR CF8M, A-351
12	Gasket	PTFE

### Figure 9502

Threaded Ends

#### Size Range:

1/4 through 2 inches

#### Design Features:

- MSS-SP-110
- Reduced Port
- Locking Handle

### Dimensions and Weights

Valve Size	Weight	Dimensions				
		A	B	C	D	E
1/4	.75	3.90	1.80	.44	2.13	1.56
3/8	.69	3.90	1.80	.50	2.13	1.56
1/2	.69	3.90	1.80	.50	2.25	1.56
3/4	1.31	4.75	2.06	.69	3.00	1.81
1	1.69	4.75	2.19	.88	3.38	1.81
1-1/4	3.09	5.75	2.63	1.00	4.00	2.00
1-1/2	4.19	5.75	2.82	1.25	4.38	2.00
2	5.84	7.20	3.00	1.50	5.39	2.00

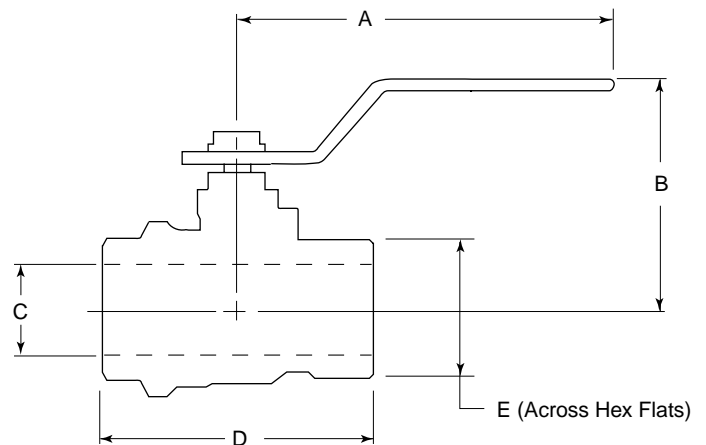
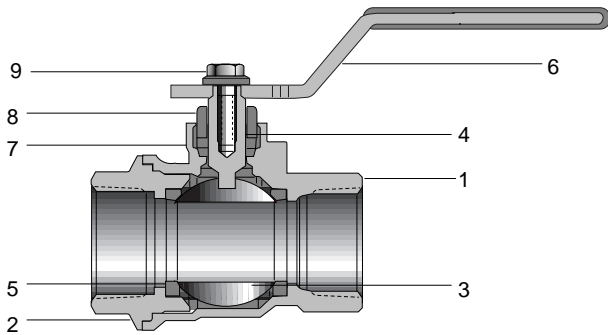

# Stainless Steel Valves



## Application Data

The following recommendations are based on data obtained from both actual plant operating experience as well as laboratory tests. These should not be considered as final recommendations for the corrosive media listed, because factors such as dissolved salts, various process compounds, temperature and velocity influence the corrosion resistance of metals and alloys. We suggest your consulting with us before making final selections.

In an effort to be specific, first and alternate choices are designated in the following table for each solution listed. In making the first choice, consideration was given to such factors as corrosion resistance, material availability and economy. An alternate choice material is listed for most solutions. The alternate choice in most cases is equal in corrosion resistance to the first choice material, but is usually more costly.

Corrosive Medium	Temp °F	First Choice	Alternate Choice
Acetic Acid			
In conc. to 100%	150	304	316
In conc. to 100%	200	316	Alloy 20
In conc. to 60%	Boiling	316	Alloy 20
60% to 100%	Boiling	Alloy 20	
Acetic Anhydride			
100%	175	316	Alloy 20
100%	244	Hastelloy C	
Acetone	Boiling	304	316
Acetyl Chloride	Boiling	Alloy 20	
Acid Mixtures			
50% HNO <sub>3</sub> - 50% H <sub>2</sub> SO <sub>4</sub>	140	304	316
50% HNO <sub>3</sub> - 50% H <sub>2</sub> SO <sub>4</sub>	200	316	Alloy 20
50% HNO <sub>3</sub> - 50% H <sub>2</sub> SO <sub>4</sub>	250	Alloy 20	
25% HNO <sub>3</sub> - 75% H <sub>2</sub> SO <sub>4</sub>	200	316	Alloy 20
25% HNO <sub>3</sub> - 75% H <sub>2</sub> SO <sub>4</sub>	250	Alloy 20	
10% HNO <sub>3</sub> - 70% H <sub>2</sub> SO <sub>4</sub>	140	304	316
10% HNO <sub>3</sub> - 70% H <sub>2</sub> SO <sub>4</sub>	Boiling	Alloy 20	
5% HNO <sub>3</sub> - 30% H <sub>2</sub> SO <sub>4</sub>	140	316	Alloy 20
5% HNO <sub>3</sub> - 30% H <sub>2</sub> SO <sub>4</sub>	230	Alloy 20	
5% HNO <sub>3</sub> - 15% H <sub>2</sub> SO <sub>4</sub>	200	316	Alloy 20
5% HNO <sub>3</sub> - 15% H <sub>2</sub> SO <sub>4</sub>	220	Alloy 20	
90% Acetic - 2% H <sub>2</sub> SO <sub>4</sub>	70	316	Alloy 20
Acid & Salt Mixtures			
Fuming HNO <sub>3</sub> - 10% KNO <sub>3</sub>	Boiling	304	316
Fuming HNO <sub>3</sub> - 10% Al(NO <sub>3</sub> ) <sub>3</sub>	Boiling	304	316
10% H <sub>2</sub> SO <sub>4</sub> - 10% CuSO <sub>4</sub>	Boiling	316	Alloy 20
10% H <sub>2</sub> SO <sub>4</sub> - 20% Fe <sub>2</sub> (SU <sub>4</sub> ) <sub>3</sub>	Boiling	Alloy 20	
Acid Mine Water	70	316	Alloy 20
Aerazine - 50	100	304	
Alcohol			
Ethyl	212	316	Alloy 20
Methanol	212	316	Alloy 20
Alkylation - Sulfuric Acid	100	Alloy 20	
Aluminum Acetate			
All Concentrations	160	304	316
All Concentrations	212	316	Alloy 20
Aluminum Chloride			
All Concentrations	75	Alloy 20	
10%	125	Alloy 20	
All Concentrations	300	Hastelloy B	
Aluminum Fluoride - 20%	160	Monel	Nickel
Aluminum Hydroxide			
Saturated	70	316	Alloy 20
10%	200	316	Alloy 20
Aluminum Sulfate			
In conc. to 50%	212	316	Alloy 20
Saturated	212	Alloy 20	
Aluminum Chrome Sulfate - 5%	70	316	Alloy 20

Corrosive Medium	Temp °F	First Choice	Alternate Choice
Alum			
(Potassium Aluminum Sulfate)			
10%	212	316	Alloy 20
All Concentrations	212	Alloy 20	
Digestion of Bauxite in H <sub>2</sub> SO <sub>4</sub> to make Alum	300	Alloy 20	
Ammonium Bicarbonate			
In conc. to 90%	212	304	316
Ammonium Carbonate			
All Concentrations	212	304	316
Ammonium Chloride (Sal Ammoniac)			
In conc. to 50%	70	316	Alloy 20
In conc. to 50%	150	Alloy 20	Monel
In conc. to 100%	212	Monel	Nickel
Ammonium Chlorostannate (Saturated)	70	316	Alloy 20
Ammonium Hydroxide	212	304	316
Ammonium Nitrate - Neutral 83% & 95%	212	304	316
Ammoniated Ammonium Nitrate	160	316	Alloy 20
Ammonium Oxalate			
In conc. to 30%	200	304	316
Ammonium Perchlorate			
In conc. to 10%	200	304	316
In conc. to 40%	200	Hastelloy C	
Ammonium Persulfate			
In conc. to 30%	200	316	Alloy 20
Ammonium Phosphate			
In conc. to 30%	200	304	316
Ammonium Sulfate			
In conc. to 10%	212	316	Alloy 20
In conc. to 50%	160	316	Alloy 20
Saturated	212	Alloy 20	
Plus free H <sub>2</sub> SO <sub>4</sub>	150	Alloy 20	Monel
Ammonium Sulfite			
In conc. to 50%	212	316	Alloy 20
Ammonium Bisulfite (Sulfite Cooking Liquor)	280	316	Alloy 20
Ammonium Thiocyanate			
In conc. to 50%	175	304	316
Amyl Alcohol - 50%	350	Alloy 20	
Amyl Mercaptan	300	Alloy 20	
Aniline - Conc.	200	316	Alloy 20
Aniline & Ferric Chloride	650	Hastelloy C	Hastelloy B
Arsenic Acid			
In conc. to 30%	200	316	Alloy 20
In conc. to 100%	200	Alloy 20	



# Stainless Steel Valves

## Application Data

Corrosive Medium	Temp °F	First Choice	Alternate Choice
Barium Carbonate			
All Concentrations	70	304	316
10%	212	304	316
Barium Chloride			
All Concentrations	70	316	Alloy 20
40%	212	Alloy 20	
Barium Nitrate -			
All Concentrations	212	304	316
Barium Sulfate			
10%	212	304	316
Concentrated	212	Alloy 20	
Benzene (Benzol)	212	304	316
Benzene Sulfonic Acid - 90%	375	Alloy 20	
Benzoic Acid			
In conc. to 100%	212	304	316
100%	400	304	316
Black Liquor (Sulfate Pulping)			
In conc. to 75% Solids	340	316	Alloy 20
Borax - 5%	212	304	316
Boric Acid			
In conc. to 50%	300	304	316
In conc. to 100%	125	304	316
Boron Trifluoride - 100%	350	304	316
Bromine			
Wet Gas	212	Hastelloy C	
Dry (Gas or Liquid)	125	Monel	Nickel
Butyric Acid			
In conc. to 5%	150	304	316
In conc. to 25%	100	Alloy 20	
In conc. to 100%	265	Hastelloy C	
Carbonic Acid			
- In conc. to 100%	212	304	316
Calcium Bisulfite			
(Sulfite Cooking Liquor)	300	316	Alloy 20
Cadmium Sulfate - 30%	212	304	316
Calcium Chlorate			
In conc. to 10%	212	316	Alloy 20
In conc. to 30%	212	Alloy 20	
In conc. to 100%	212	Hastelloy C	
Calcium Chloride			
In conc. to 80%	125	316	Alloy 20
In conc. to 100%	180	Alloy 20	
Calcium Hydroxide			
In conc. to 50%	212	316	Alloy 20
Calcium Hypochlorite			
3 g.p.l. Available Chlorine	70	316	Alloy 20
In conc. to 40 g.p.l. available Chlorine	125	Hastelloy C	
Carbon Tetrachloride			
C.P.	200	316	Alloy 20
Plus H <sub>2</sub> O	200	Alloy 20	
Cellulose Acetate	150	316	Alloy 20
Chloroacetic Acid -			
In conc. to 100%	212	Hastelloy C	
Chlorobenzene - Concentrated	175	316	Alloy 20
Chloroform - Concentrated	212	304	316
Chlorine Dioxide			
Solution from absorbers to bleach		317	Alloy 20
Solution from neutralizer		Alloy 20	

Corrosive Medium	Temp °F	First Choice	Alternate Choice
Chlorine Trifluoride	100	Monel	Nickel
Chlorine Gas-moist, saturated	70	Hastelloy C	
Chlorosulfonic Acid - 99.5%	100	304	316
Chromic Acid			
5%	70	304	316
In conc. to 50%	125	Alloy 20	
Citric Acid -			
In conc. to 50%	212	316	Alloy 20
All concentrations	212	Alloy 20	
Cola Syrup	70	304	316
Coffee	300	304	316
Copper Chloride -			
In conc. to 100%	70	Hastelloy C	
Copper Cyanide -			
In conc. to Saturated	212	304	316
Copper Nitrate -			
in conc. to Saturated	212	304	316
Copper Sulfate			
In conc. to saturated	212	316	Alloy 20
Plus 10% H <sub>2</sub> SO <sub>4</sub>	150	Alloy 20	
Creosote	200	304	316
Cresylic Acid	350	Alloy 20	
Cyanogen Gas	70	304	316
Dichloroethane	212	304	316
Diethanolamine	212	316	304
Dinitrochlorobenzene			
Melted and Solidified	70	304	316
Distilling Wort	212	304	316
Dyewood Liquor		304	316
Epsom Salt (MgSO <sub>4</sub> ) -			
in conc. to saturated	212	304	316
Ether	70	304	316
Ethylene Chloride, dry	70	304	316
Ethyl Acetate, conc.	200	304	316
Ethyl Chloride			
Dry	600	304	316
10%	175	Alloy 20	
Fatty Acids (Tall Oil Distillation)			
High Rosin Acids - over 50%	525	316	Alloy 20
High Fatty Acids - over 60%	525	317	Hastelloy C
Ferric Chloride-			
18% (HCl-24.7%)	700	Hastelloy C	Hastelloy B
Ferric Nitrate			
In conc. to 100%	125	304	316
In conc. to 100%	212	Alloy 20	
Ferric Sulfate			
10%	212	316	Alloy 20
In conc. to 100%	70	316	Alloy 20
In conc. to 100%	150	Alloy 20	
Fluorine-Dry	800	Nickel	Monel
Formaldehyde			
In conc. to 100%	125	316	
In conc. to 100%	212	Alloy 20	
Formic Acid			
In conc. to 100%	125	316	Alloy 20
In conc. to 100%	212	Alloy 20	
Fruit Juices	212	304	316
Furfural-In conc. to 100%	212	304	316

# Stainless Steel Valves



## Application Data

Corrosive Medium	Temp °F	First Choice	Alternate Choice
Gallic Acid-In conc. to 100%	212	304	316
Glue (Acid Solutions)	140	316	Alloy 20
Hydrazine	125	304	
Hydrobromic Acid- In conc. to 50%	200	Hastelloy B	
Hydrochloric Acid- In conc. to 37%	212	Hastelloy B	
Hydrocyanic Acid	125	316	Alloy 20
Hydrofluoric Acid			
In conc. to anhydrous (Air free)	212	Monel	
In conc. 90% to Anhydrous	100	Alloy 20	
Hydrogen Fluoride - Gas	500	Monel	Nickel
Hydrogen Peroxide			
In conc. to 90%	150	304	316
Hydrogen Sulfide			
Dry	900	304	316
Wet	125	316	Alloy 20
Indoform	70	316	Alloy 20
Ink		316	Alloy 20
Isomerization- Butane (HCl & AlCl <sub>3</sub> )	100	Hastelloy B	
Kraft Mill Solutions			
Black Liquor			
In conc. to 75% solids	340	316	Alloy 20
White Liquor	300	316	Alloy 20
Green Liquor	260	316	Alloy 20
Lactic Acid			
In conc. to 100%	160	316	Alloy 20
In conc. to 100%	212	Alloy 20	
Lard	Hot	304	316
Lead Nitrate			
In conc. to 100%	70	304	316
In conc. to 60%	212	316	Alloy 20
Linseed Oil	70	304	316
Plus H <sub>2</sub> SO <sub>4</sub>	392	Alloy 20	
Magnesium Chloride			
In conc. to 5%	70	316	Alloy 20
In conc. to 50%	175	Alloy 20	
In conc. to 40%	300	Nickel	Hastelloy B
Magnesium Nitrate			
In conc. to 10%	212	304	316
In conc. to 100%	70	304	316
Magnesium Sulfate			
In conc. to 100%	212	316	Alloy 20
Maleic Acid	212	316	Alloy 20
Maleic Anhydride	350	316	Alloy 20
Methyl Chloride - Dry	212	304	316
Mayonnaise	70	304	316
Methylene Chloride - Dry	212	304	316
Milk	212	304	316
Mineral Oil	300	304	316
Monochloroacetic Acid - 70%	120	Hastelloy C	Alloy 20
Monoethanolamine			
In conc. to 100%	212	304	316
Mustard	70	316	Alloy 20
Nickel Sulfate-in conc. to 100%	212	316	Alloy 20
Nicotine Sulfate - 8% to 15%	200	316	Alloy 20

Corrosive Medium	Temp °F	First Choice	Alternate Choice
Nitric Acid			
In conc. to 80%	125	304	316
In conc. to 65%	212	304	316
50 to 85%	150	Alloy 20	
Fuming - 86% and Higher	110	Alloy 20	
Nitro Cellulose	70	304	316
Nitrogen Tetroxide	100	304	316
Nitrous Acid - All conc.	70	304	316
Oleic Acid			
70	70	304	316
400	400	316	Alloy 20
600	600	Alloy 20	
Oxalic Acid			
In conc. to 90%	70	304	316
All Conc.	212	Alloy 20	
Paraffin	Hot	304	316
Pentaborane	70	304	
Petroleum Ether		304	316
Phenol (Carbolic Acid)			
C.P. or crude	360	304	316
Vapors	700	Alloy 20	Hastelloy B
Phosphoric Acid			
In conc. to 60%	200	316	Alloy 20
60 to 85% - Aerated	200	316	Alloy 20
In conc. to 85% - Air Free	200	Alloy 20	Hastelloy B
85% to 100% Air Free	275	Hastelloy B	
Photographic Developer	70	316	Alloy 2
Phthalic Acid	360	316	Alloy 2
Phthalic Anhydride	285	316	Alloy 2
Picric Acid - in conc. to 100%	212	304	316
Propionic Acid - 66%	300	Alloy 20	Hastelloy C
Propyl Acetate	192	304	316
Polyvinyl Acetate, 2% H <sub>2</sub> SO <sub>4</sub>	150	316	Alloy 20
Potassium Bicarbonate			
In conc. to 100%	70	30.4	316
In conc. to 40%	212	316	Alloy 20
Potassium Carbonate			
In conc. to 100%	70	314	316
In conc. to 60%	212	304	316
Potassium Chlorate			
In conc. to 100%	70	316	Alloy 20
In conc. to 30%	200	316	Alloy 20
Potassium Chloride			
Quiescent - 5%	160	Alloy 20	Monel
Aerated - 20%	150	Alloy 20	Monel
Saturated	212	Monel	
Potassium Dichromate			
In conc. to 60%	212	304	316
In conc. to 100%	70	304	316
Potassium Ferricyanide			
In conc. to 100%	70	304	316
In conc. to 60%	200	316	Alloy 20
Potassium Ferrocyanide			
In conc. to 30%	200	304	316
In conc. to 90%	200	Alloy 20	
Potassium Hydroxide (Caustic Potash)			
20%	200	304	316
50%	250	Alloy 20	Nickel
75%	275	Nickel	
100%	750	Inconel	



# Stainless Steel Valves

## Application Data

Corrosive Medium	Temp °F	First Choice	Alternate Choice
Potassium Nitrate - In conc. to 100%	212	304	316
Potassium Oxalate In conc. to 100%	70	304	316
In conc. to 40%	212	304	316
Potassium Sulfate In conc. to 100%	70	304	316
In conc. to 20%	200	316	Alloy 20
Pyrogallic Acid In conc. to 100%	70	304	316
In conc. to 60%	200	Alloy 20	
Rayon Spin Bath 5 to 15% H <sub>2</sub> SO <sub>4</sub>	150	Alloy 20	
17% H <sub>2</sub> SO <sub>4</sub>	190	Hastelloy C	
Sea Water	160	Alloy 20	Monel
Selenious Acid - In conc. to 30%	212	304	316
Silver Nitrate In conc. to 100%	160	304	316
In conc. to 70%	212	Alloy 20	
Sodium Bicarbonate In conc. to 100%	70	304	316
In conc. to 40%	212	304	316
Sodium Carbonate All concentrations	70	304	316
In conc. to 50%	212	316	Alloy 20
All concentrations	212	Alloy 20	
Sodium Chlorate In conc. to 100%	70	316	Alloy 20
In conc. to 70%	212	316	Alloy 20
Sodium Chloride Quiescent - 5%	160	Alloy 20	Monel
Aerated - 20%	175	Alloy 20	Monel
Saturated	212	Monel	
Sodium Hydrosulfide - 65% to 68%	176	304	316
Sodium Hydroxide (Caustic Soda) 20%	200	304	316
50%	250	Alloy 20	Nickel
75%	275	Nickel	
100%	750	Inconel	
Sodium Hypochlorite 3 g.p.l. Available Chlorine	70	316	Alloy 20
In conc. to 40 g.p.l. available Chlorine	125	Hastelloy C	
Sodium Nitrate 70%	212	304	316
100% Molten	900	304	316
Sodium Sulfate In conc. to 30%	212	316	Alloy 20
Concentrated	212	316	Alloy 20
Sodium Sulfide In conc. to 100%	70	316	Alloy 20
In conc. to 50%	200	Alloy 20	
Sodium Sulfite 10%	175	304	316
30%	200	Alloy 20	
Spirits of Wine		304	316
Starch Solution	100	304	316

Corrosive Medium	Temp °F	First Choice	Alternate Choice
Stearic Acid - Conc.	400	316	Alloy 20
Sugar & Sugar Solutions		304	316
Sulfonic Acid	130	304	316
Sulfur Dioxide Gas, Moist	200	316	Alloy 20
Gas, Dry	575	304	316
Sulfur, Molten Dry	300	316	Alloy 20
Plus Moisture	300	Alloy 20	
Sulfur Monochloride (Plus CC1 <sub>4</sub> )	200	Nickel	Monel
Sulfuric Acid All Concentrations	125	Alloy 20	
5%	200	Alloy 20	
10%	175	Alloy 20	
20-40%	150	Alloy 20	
50-60%	140	Alloy 20	
70-80%	130	Alloy 20	
90%	145	Alloy 20	
93-100%	175	Alloy 20	
10-25%	180	Hastelloy C	
25-50%	175	Hastelloy B	
60%	180	Hastelloy B	
80%	210	Hastelloy B	
90%	220	Hastelloy B	
Oleum	175	Alloy 20	
Sulfurous Acid All Concentrations	300	Alloy 20	
All Concentrations	150	316	Alloy 20
Tall Oil	525	316	
Tannic Acid	150	316	Alloy 20
Tanning Liquor		304	316
Tartaric Acid 10%	212	304	316
50%	212	316	Alloy 20
Trisodium Phosphate - 20%	175	304	316
Turpentine		304	316
Unsymmetrical Dimethyl Hydrazine	140	304	
Urea	260	316	
Vegetable Juices	212	316	Alloy 20
Vinegar	150	304	316
Water, High Purity	750	304	316
Zinc Ammonium Chloride - 12 <sup>o</sup> Be	180	Hastelloy C	Alloy 20
Zinc Chloride In conc. to 70%	70	316	Alloy 20
In conc. to 90%	150	Alloy 20	
In conc. to 50%	212	Monel	Hastelloy B
All conc. to 100%	212	Hastelloy B	
Zinc Cyanide - Moist	70	304	316
Zinc Nitrate, 10%	175	304	316
Zinc Sulfate 40%	212	316	Alloy 20
Saturated	70	316	Alloy 20