

PARALLEL SLIDE GATE VALVES
1000 - 1690 - 2850 CLASS
SIZES 5" to 24"



VALVES LTD



INDEX & PRODUCT REVIEW

Full Bore, Standard Bore and Reduced Bore Parallel Slide Gate Valves

The HH Valves range of full bore, standard bore and reduced bore high pressure parallel slide gate valves is primarily designed for isolation of steam and feed water as well as many other applications.

Features and advantages

A parallel slide valve seat achieves tightness by utilising the line pressure, rather than by mechanical effort which can be the case with a wedge gate valve design.

This eliminates the possibility of binding which may occur with a wedge gate valve as a result of large temperature fluctuations within the valve during service.

The effort required to seal a parallel slide valve is therefore much reduced over that required to seal a wedge gate valve. This is an advantage when fitting actuators with the parallel slide design allowing smaller sized actuators to be used, resulting in cost savings.

A parallel slide valve is ideally suited to in-line maintenance with the re-machining of all internal components being on-centre and with the seat faces only needing to be nominally parallel.

The self-aligning disc design of the parallel slide valve creates a wiping action over the seat faces to assist in the removal of contaminants. The hard-faced stellite seats and discs have a sufficient thickness of deposit to allow several re-machining operations to be performed during maintenance before new parts are required.

Pillar and stem stop design provides accurate guidance for the valve stem and gives open to close visual position indication.

All high pressure valves incorporate a pressure seal bonnet design. The internal pressure acting on the bonnet acts on the resilient, pre-formed, compressed graphite seal ring to form the bonnet seal.

The parallel slide design includes a backseat feature which is used when the valve is in the fully open position. The backseat is integrally incorporated within the bonnet by means of a direct, stellite deposited seating face. The stem collar provides the other sealing face and when lapped together with the backseat face, the seal is made. The backseat should **ONLY** be used to isolate the gland from the line medium in instances when gland leakage is evident and until such time that the valve can be de-pressurised and repaired. **UNDER NO CIRCUMSTANCES SHOULD THE BACKSEAT BE USED TO ALLOW GLAND REPAIR WHILE THE VALVE AND SYSTEM IS PRESSURISED.**

The disc retaining clips are screwed onto the stud during valve assembly and locked in position. This provides sufficient loading and freedom of movement to allow proper alignment and accurate contact to be maintained over the lapped seat and disc sealing faces during thermal expansion and contraction, regardless of the valve orientation.

For start-up and regulating duties a vee-port seat with full-faced stellite deposited discs can be provided, allowing accurate flow rate characteristics to be achieved.



Pressure Seal Arrangement

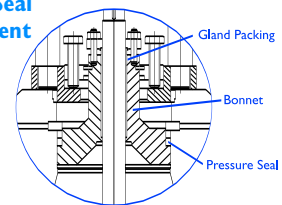

Backseat Arrangement

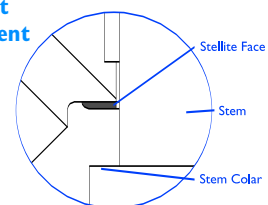

Disc Retaining Clip

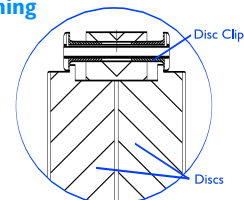

Regulating Duty Vee Port Seat

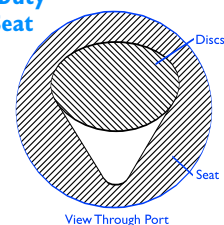



BY-PASS EQUALISING DEVICES

HH Valves high pressure full bore, standard bore and reduced bore parallel slide valves are selected on the basis of the flow conditions and the allowable pressure drop for each application.

By-pass Valves

A by-pass valve can be fitted to equalise the pressure on either side of a closed main valve. It can also be used to warm-up the downstream pipe-work for short periods of time before the main valve is opened, substantially reducing the load to open the valve.

An equalising by-pass valve is fitted to overcome the possibility of intergate pressure locking. This system uses a standard by-pass valve as described above, but has an additional small bore pipe that connects the main valve intergate chamber to that of the by-pass valve. When the main valve is closed and the by-pass is opened the intergate pressure is evacuated. The main valve, in this instance, remains bi-directional.

All by-pass valves will be HH Valves, small bore, forged steel design, matching the properties of the main valve and, if required, can be fitted at our factory together with the associated pipe-work.

A more basic method of overcoming the possibility of intergate pressure locking is to fit an equalising pipe. This consists of a simple pipe which connects the main valve intergate chamber to the upstream port. This will automatically equalise the pressure between that in the centre chamber and the upstream side of the valve.

An even simpler method is to drill a small hole in the upstream seat which will again automatically equalise the pressure in the centre chamber with that in the upstream side.

In both these instances the main valve will become uni-directional and would therefore be fitted with an arrow to clearly show the direction of flow.

Intergate Pressure Build-up and Lock-up

Thermal expansion can create pressure-locking when a fluid, at ambient temperature, is trapped in the intergate cavity of the valve body. When the plant is on start-up and heat is seen by the valve when in the closed position, excessive pressure can be generated in the intergate cavity, sometimes exceeding the maximum pressure rating of the valve. This can be demonstrated by difficulty in opening the valve or by the tripping out of the actuator when starting the opening sequence.

Pressure build-up or hydraulic pressure lock-up can occur on high pressure feed water services when the valve is being closed. The stem, when operating the valve from open to close, will displace the water and until the valve is almost closed the displaced water will disperse along the pipeline. Once the seat fully contacts the disc any further travel cannot displace the water and pressure build or hydraulic lock-up, within the intergate cavity, can occur.

The solution to both these problems is to fit one of the equalising devices described above.

Electric Motor Operation of the Main and By-pass Valves

The by-pass must be operated in the correct sequence with the opening and closing of the main valve.

With both the main valve and by-pass valve closed the actuators should be configured so that it is not possible to open the main valve until the by-pass valve is opened.

Open the by-pass valve fully (do not inch the opening process).

Open the main valve.

When the main valve is fully open, the by-pass valve should be set to close automatically.

The signal to close the main valve should automatically open the by-pass valve.

When the main valve reaches the fully closed position the by-pass valve should be set to automatically close.

The cycle is now complete.

When an equalising pipe is connected between the by-pass valve and the main intergate cavity, the pressure will always equalise to the upstream when both valve are closed.

When the main valve is fitted with a pressure equalising valve, in addition to the standard by-pass valve, this is hand operated and should be locked in the open position during normal operation.

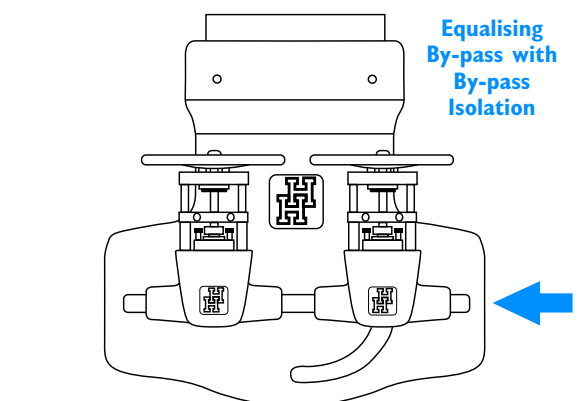
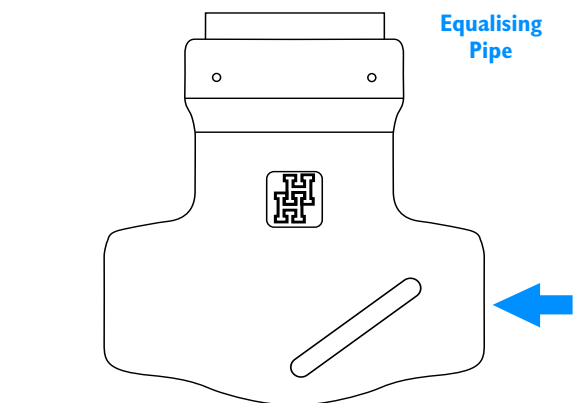
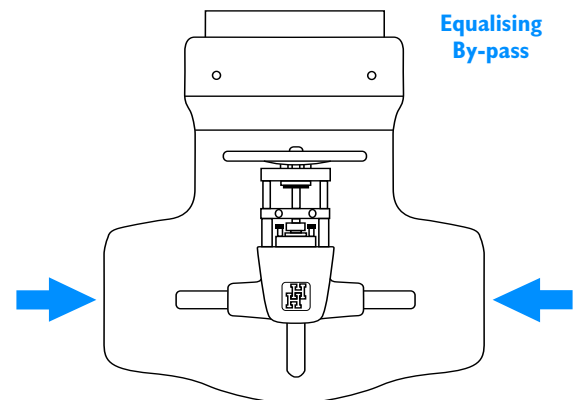
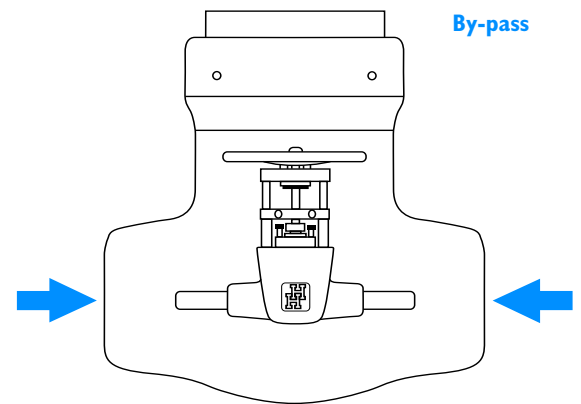



MATERIAL & PARTS SPECIFICATION

Fig No. 5095, Butt Weld Ends, Class 1000

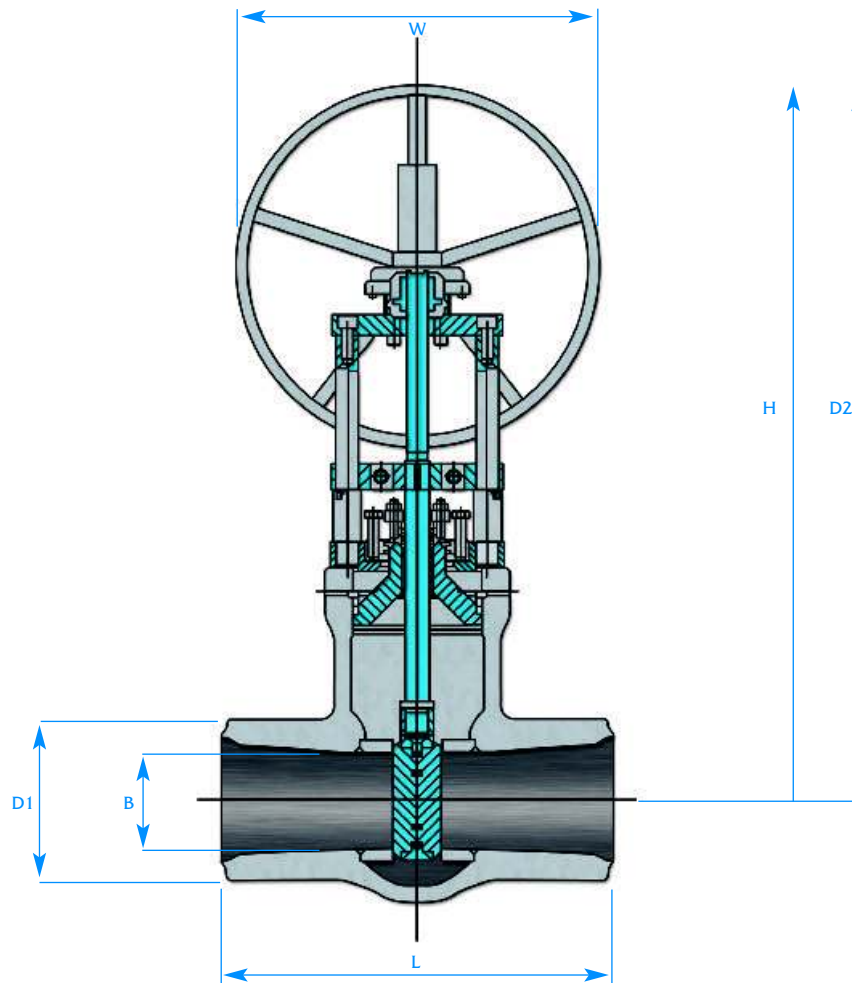

Hydrostatic Shell & Seat Leak Test Pressures PSIG - BAR

Pressure Class	Materials							
	ASTM A-216 WCB		ASTM A-217 WC6		ASTM A-217 WC9		ASTM A-217 C12A	
	Shell	Seat	Shell	Seat	Shell	Seat	Shell	Seat
1000	3725	2720	3750	2750	3750	2750	3750	2750
	256	187.5	259	189.7	259	189.7	259	189.7

The test values are calculated from separate sections in ASME B16.34 and are not exact equivalents.

Materials of Construction

Part Description	Carbon Steel Specification Fig No. 5095	Alloy Steel Specification Fig No. L5095	Alloy Steel Specification Fig No. R5095	C12A Alloy Steel Specification Fig No. U5095
Body	ASTM A216 Gr. WCB†	ASTM A217 Gr WC6	ASTM A217 Gr WC9	ASTM A217 Gr C12A
Bonnet	ASTM A216 Gr. WCB† Stellite Faced	ASTM A182 F11 Stellite Faced	ASTM A182 F22 Stellite Faced	ASTM A182 F91 Stellite Faced
Cover	ASTM A516 Gr.60	ASTM A182 F11	ASTM A182 F11	ASTM A182 F11
Stem	ASTM A565 - XM 32	ASTM A565 - XM 32	ASTM A565 - XM 32	ASTM A565 - XM 32
Gland	ASTM B150 Gr.630	ASTM B150 Gr.630	ASTM B150 Gr.630	ASTM B150 Gr.630
Seats	ASTM A105 Stellite Faced	ASTM A182 F11 Stellite Faced	ASTM A182 F22 Stellite Faced	ASTM A182 F91 Stellite Faced
Yoke Sleeve	ASTM A439 - D2	ASTM A439 - D2	ASTM A439 - D2	ASTM A439 - D2
Handwheel	Cast Iron/Steel	Cast Iron/Steel	Cast Iron/Steel	Cast Iron/Steel
Disc	ASTM A216 Gr WCB Stellite Faced	ASTM A182 F11 Stellite Faced	ASTM A182 F22 Stellite Faced	ASTM A182 F91 Stellite Faced
Gland Packing	Flexible Graphite Rings	Flexible Graphite Rings	Flexible Graphite Rings	Flexible Graphite Rings
Pressure Seal Ring	Expanded Graphite	Expanded Graphite	Expanded Graphite	Expanded Graphite

† 0.25% Carbon max.

Hardfacing is stellite or equivalent



VALVE DIMENSIONS

Fig No. 5095, Butt Weld Ends, Class 1000

ASME Class 1000 FULL BORE											
Size mm	Fig No.	Weight lbs kgs	Length L	Casting OD		Valve Bore B	Withdrawal Space D2	H/W Dia		CV	K Factor
				DI				H	W		
5	5095 - FB	290	17.01	5	.79	4.41	46.06	30.35	18	1624	0.13
		132	432		147	112	1170	771	457		
6		466	20.00		7.05	5.75	56.22	37.60	24	2840	0.12
		212	508		179	146	1428	955	610		
8		1054	25.98		10.94	7.48	82.56	58.94	30	4945	0.11
		479	660		278	190	2097	1497	762		
10		1577	30.98		12.24	8.98	95.67	68.35	36	7255	0.11
		717	787		311	228	2430	1736	914		
12		2376	35.98		15.94	10.94	113.27	80.59	36	11004	0.11
		1080	914		405	278	2877	2047	914		
14		2988	39.02		16.46	12.20	121.57	84.72	24	13832	0.10
		1358	991		418	310	3088	2152	610		
16		4574	42.99		18.90	13.66	134.29	92.87	24	17523	0.10
		2079	1092		480	347	3411	2359	610		
18		7817	47.99		19.33	15.59	167.17	118.43	36	23116	0.10
		3553	1219		491	396	4246	3008	914		
20		7682	52.01		20.35	17.32	167.17	118.43	36	28828	0.10
		3492	1321		517	440	4246	3008	914		
24		9148	60.98		22.87	19.29	175.59	123.39	36	36125	0.09
		4158	1549		581	490	4460	3134	914		

ASME Class 1000 STANDARD BORE											
Size mm	Fig No.	Weight lbs kgs	Length L	Casting OD		Valve Bore B	Withdrawal Space D2	H/W Dia		CV	K Factor
				DI				H	W		
5	NA					NA					
6	5095 - PB	323	20.00		7.44	4.41	46.06	30.35	18	1384	0.43
		147	508		189	112	1170	771	457		
8		579	25.98		10.08	5.75	56.22	37.60	24	2402	0.41
		263	660		256	146	1428	955	610		
10		1164	30.98		11.46	7.48	82.56	58.94	30	4280	0.33
		529	787		291	190	2097	1497	762		
12		1749	35.98		14.33	8.98	95.67	68.35	36	6370	0.29
		795	914		364	228	2430	1736	914		
14		2035	39.02		15.94	9.61	99.80	70.83	36	7024	0.35
		925	991		405	244	2535	1799	914		
16		2752	42.99		17.80	10.94	113.27	80.59	36	9047	0.37
		1251	1092		452	278	2877	2047	914		
18		3826	47.99		19.92	12.20	121.57	84.72	24	11152	0.39
		1739	1219		506	310	3088	2152	610		
20		5419	52.01		22.28	13.66	134.29	92.87	24	14092	0.37
		2463	1321		566	347	3411	2359	610		
24		8307	60.98		22.95	16.46	167.17	118.43	36	21042	0.35
		3776	1549		583	418	4246	3008	914		

ASME Class 1000 REDUCED BORE											
Size mm	Fig No.	Weight lbs kgs	Length L	Casting OD		Valve Bore B	Withdrawal Space D2	H/W Dia		CV	K Factor
				DI				H	W		
5	NA					NA					
6	NA					NA					
8	5095 - RB	383	25.98		8.90	4.41	46.06	30.35	18	997	2.39
		174	660		226	112	1170	771	457		
10		647	30.98		11.65	5.75	56.22	37.60	24	1743	1.98
		294	787		296	146	1428	955	610		
12		1263	35.98		14.37	7.48	82.56	58.94	30	3329	1.07
		574	914		365	190	2097	1497	762		
14		1826	39.02		15.83	8.98	95.67	68.35	36	5518	0.57
		830	991		402	228	2430	1736	914		
16		2132	42.99		16.93	9.61	99.80	70.83	36	5629	0.95
		969	1092		430	244	2535	1799	914		
18		2913	47.99		19.92	10.94	113.27	80.59	36	7495	0.86
		1324	1219		506	278	2877	2047	914		
20		3978	52.01		22.28	12.20	121.57	84.72	24	9262	0.87
		1808	1321		566	310	3088	2152	610		
24		5909	60.98		23.07	13.66	134.29	92.87	24	10463	1.40
		2686	1549		586	347	3411	2359	610		



MATERIAL & PARTS SPECIFICATION

Fig No. 5096, Butt Weld Ends, Class 1690

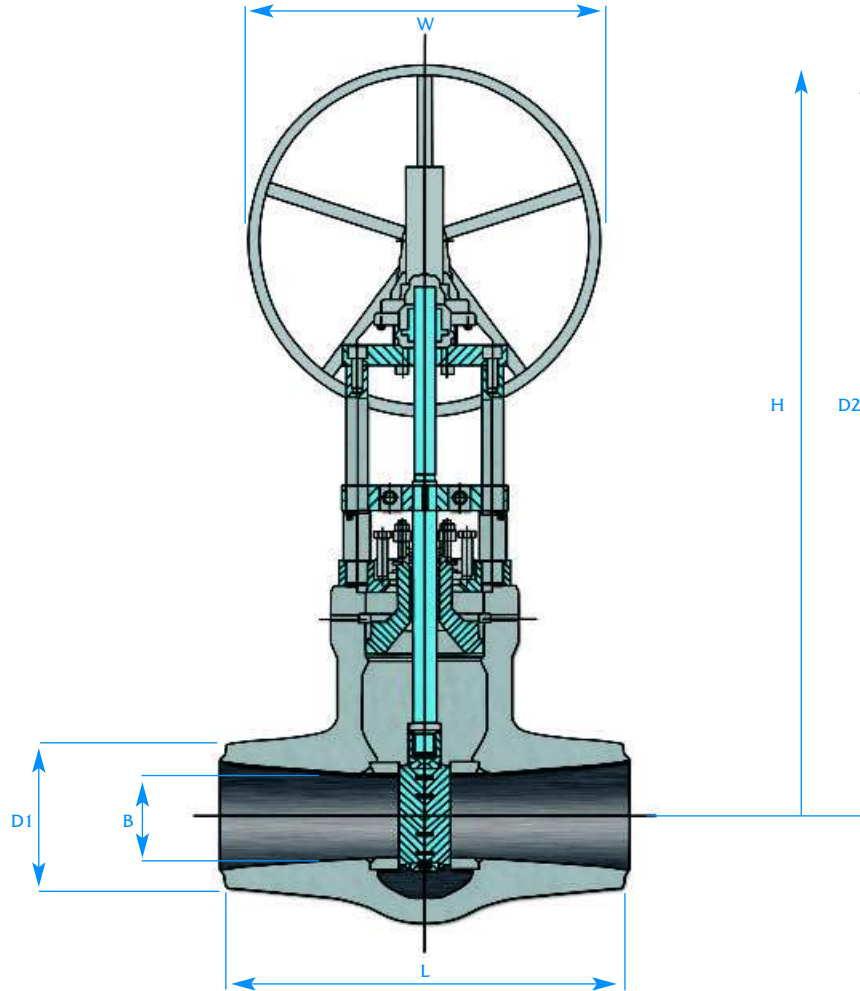

Hydrostatic Shell & Seat Leak Test Pressures PSIG - BAR

Pressure Class	Materials							
	ASTM A-216 WCB		ASTM A-217 WC6		ASTM A-217 WC9		ASTM A-217 C12A	
	Shell	Seat	Shell	Seat	Shell	Seat	Shell	Seat
1690	6275	4595	6350	4650	6350	4650	6350	4650
	432	316.5	437	320.5	437	320.5	437	320.5

The test values are calculated from separate sections in ASME B16.34 and are not exact equivalents.

Materials of Construction

Part Description	Carbon Steel Specification Fig No. 5096	Alloy Steel Specification Fig No. L5096	Alloy Steel Specification Fig No. R5096	C12A Alloy Steel Specification Fig No. U5096
Body	ASTM A216 Gr. WCB†	ASTM A217 Gr WC6	ASTM A217 Gr WC9	ASTM A217 Gr C12A
Bonnet	ASTM A216 Gr. WCB† Stellite Faced	ASTM A182 F11 Stellite Faced	ASTM A182 F22 Stellite Faced	ASTM A182 F91 Stellite Faced
Cover	ASTM A516 Gr.60	ASTM A182 F11	ASTM A182 F11	ASTM A182 F11
Stem	ASTM A565 - XM 32	ASTM A565 - XM 32	ASTM A565 - XM 32	ASTM A565 - XM 32
Gland	ASTM B150 Gr.630	ASTM B150 Gr.630	ASTM B150 Gr.630	ASTM B150 Gr.630
Seats	ASTM A105 Stellite Faced	ASTM A182 F11 Stellite Faced	ASTM A182 F22 Stellite Faced	ASTM A182 F91 Stellite Faced
Yoke Sleeve	ASTM A439 - D2	ASTM A439 - D2	ASTM A439 - D2	ASTM A439 - D2
Handwheel	Cast Iron/Steel	Cast Iron/Steel	Cast Iron/Steel	Cast Iron/Steel
Disc	ASTM A216 Gr WCB Stellite Faced	ASTM A182 F11 Stellite Faced	ASTM A182 F22 Stellite Faced	ASTM A182 F91 Stellite Faced
Gland Packing	Flexible Graphite Rings	Flexible Graphite Rings	Flexible Graphite Rings	Flexible Graphite Rings
Pressure Seal Ring	Expanded Graphite	Expanded Graphite	Expanded Graphite	Expanded Graphite

† 0.25% Carbon max.

Hardfacing is stellite or equivalent



VALVE DIMENSIONS

Fig No. 5096, Butt Weld Ends, Class 1690

ASME Class 1690 FULL BORE												
Size mm	Fig No.	Weight lbs kgs	Length L	Casting OD		Valve Bore B	Withdrawal Space D2	Height Closed H	H/W Dia		CV	K Factor
				DI					W			
5	5096 - FB	337	19.02	5.47	3.94	41.34	27.13	24	945	0.34		
		153	483	139	100	1050	689	610				
6		711	22.01	8.03	5.16	55.83	37.32	30	2210	0.13		
		323	559	204	131	1418	948	762				
8		1148	27.99	10.24	6.42	79.33	56.89	30	2855	0.24		
		522	711	260	163	2015	1445	762				
10		2114	34.02	11.81	7.87	89.88	63.54	30	4116	0.27		
		961	864	300	200	2283	1614	762				
12		3674	39.02	15.43	9.84	113.46	80.63	36	7747	0.15		
		1670	991	392	250	2882	2048	914				
14		4981	41.97	17.24	10.94	133.62	96.22	36	9976	0.14		
		2264	1066	438	278	3394	2444	914				
16		6523	47.01	17.48	12.20	140.00	99.41	36	11215	0.19		
		2965	1194	444	310	3556	2525	914				
18		10446	52.99	17.83	14.09	161.34	112.56	36	16725	0.14		
		4748	1346	453	358	4098	2859	914				
20		11231	57.99	22.24	15.83	161.34	112.56	36	22210	0.12		
		5105	1473	565	402	4098	2859	914				
24		13539	65.98	25.75	17.32	171.26	118.11	36	18650	0.36		
		6154	1676	654	440	4350	3000	914				

ASME Class 1690 STANDARD BORE												
Size mm	Fig No.	Weight lbs kgs	Length L	Casting OD		Valve Bore B	Withdrawal Space D2	Height Closed H	H/W Dia		CV	K Factor
				DI					W			
5	NA			NA								
6	5096 - PB	392	22.01	7.36	3.94	41.34	27.13	24	1052	0.58		
		178	559	187	100	1050	689	610				
8		821	27.99	9.09	5.16	55.83	37.32	30	1829	0.57		
		373	711	231	131	1418	948	762				
10		1410	34.02	11.77	6.42	79.33	56.89	30	2858	0.57		
		641	864	299	163	2015	1445	762				
12		2308	39.02	14.88	7.87	89.88	63.54	30	4506	0.46		
		1049	991	378	200	2283	1614	762				
14		2913	41.97	14.41	8.54	106.02	76.85	36	5124	0.53		
		1324	1066	366	217	2693	1952	914				
16		4030	47.01	17.87	9.84	113.46	80.63	36	6944	0.50		
		1832	1194	454	250	2882	2048	914				
18		5555	52.99	20.24	10.94	133.62	96.22	36	8480	0.54		
		2525	1346	514	278	3394	2444	914				
20		7590	57.99	21.42	12.20	140.00	99.41	36	10607	0.53		
		3450	1473	544	310	3556	2525	914				
24		12294	65.98	24.84	14.09	162.05	112.56	36	15639	0.51		
		5588	1676	631	358	4116	2859	914				

ASME Class 1690 REDUCED BORE												
Size mm	Fig No.	Weight lbs kgs	Length L	Casting OD		Valve Bore B	Withdrawal Space D2	Height Closed H	H/W Dia		CV	K Factor
				DI					W			
5	NA			NA								
6	NA			NA								
8	5096 - RB	460	27.99	9.41	3.94	41.34	27.13	24	777	3.18		
		209	711	239	100	1050	689	610				
10		942	34.02	11.26	5.16	55.83	37.32	30	1411	2.34		
		428	864	286	131	1418	948	762				
12		1544	39.02	14.49	6.42	79.33	56.89	30	2276	1.81		
		702	991	368	163	2015	1445	762				
14		2416	41.97	15.28	7.87	89.88	63.54	30	3910	0.91		
		1098	1066	388	200	2283	1614	762				
16		3095	47.01	16.93	8.54	106.02	76.85	36	4251	1.33		
		1407	1194	430	217	2693	1952	914				
18		5410	52.99	20.00	9.84	113.46	80.63	36	5887	1.12		
		2459	1346	508	250	2882	2048	914				
20		5854	57.99	20.91	10.94	133.62	96.22	36	7207	1.14		
		2661	1473	531	278	3394	2444	914				
24		8261	65.98	25.20	12.20	140.00	99.41	36	8066	1.90		
		3755	1676	640	310	3556	2525	914				



MATERIAL & PARTS SPECIFICATION

Fig No. 5099, Butt Weld Ends, Class 2850

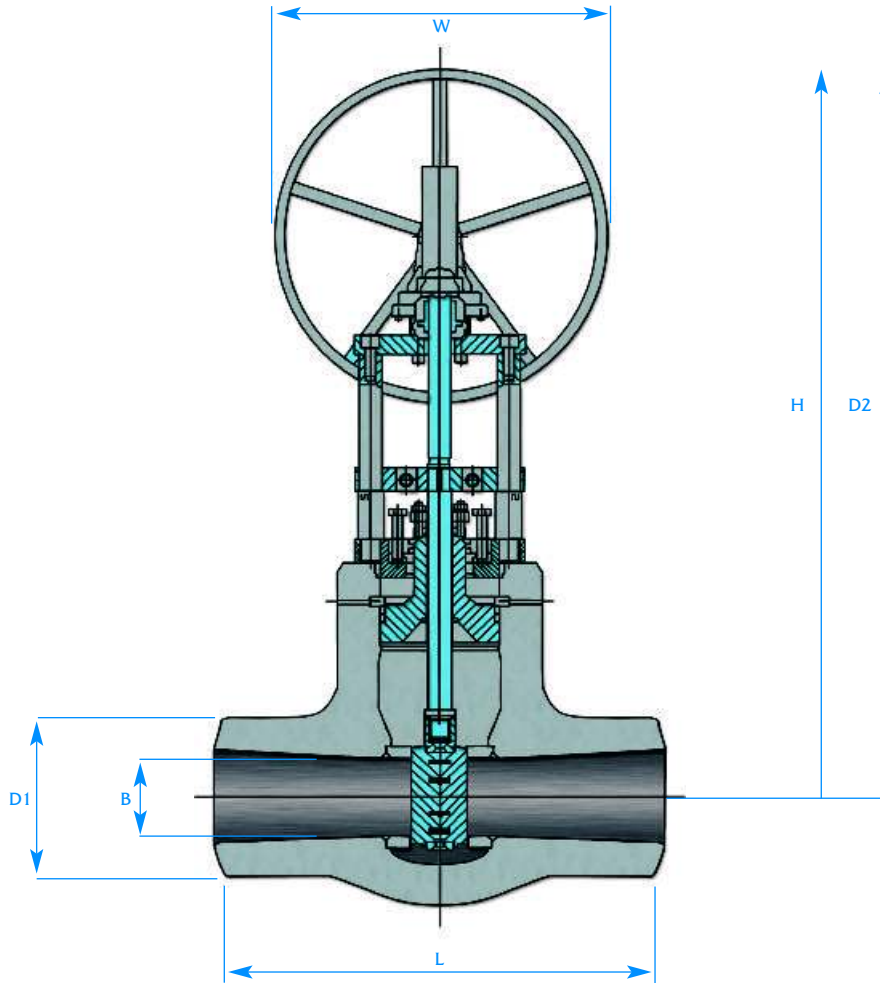

Hydrostatic Shell & Seat Leak Test Pressures PSIG - BAR

Pressure Class	Materials							
	ASTM A-216 WCB		ASTM A-217 WC6		ASTM A-217 WC9		ASTM A-217 C12A	
	Shell	Seat	Shell	Seat	Shell	Seat	Shell	Seat
2850	10575	7740	10700	7840	10700	7840	10700	7840
	728	533.7	737	540.5	737	540.5	737	540.5

The test values are calculated from separate sections in ASME B16.34 and are not exact equivalents.

Materials of Construction

Part Description	Carbon Steel Specification Fig No. 5099	Alloy Steel Specification Fig No. L5099	Alloy Steel Specification Fig No. R5099	C12A Alloy Steel Specification Fig No. U5099
Body	ASTM A216 Gr. WCB†	ASTM A217 Gr WC6	ASTM A217 Gr WC9	ASTM A217 Gr C12A
Bonnet	ASTM A216 Gr. WCB† Stellite Faced	ASTM A182 F11 Stellite Faced	ASTM A182 F22 Stellite Faced	ASTM A182 F91 Stellite Faced
Cover	ASTM A516 Gr.60	ASTM A182 F11	ASTM A182 F11	ASTM A182 F11
Stem	ASTM A565 - XM 32	ASTM A565 - XM 32	ASTM A565 - XM 32	ASTM A565 - XM 32
Gland	ASTM B150 Gr.630	ASTM B150 Gr.630	ASTM B150 Gr.630	ASTM B150 Gr.630
Seats	ASTM A105 Stellite Faced	ASTM A182 F11 Stellite Faced	ASTM A182 F22 Stellite Faced	ASTM A182 F91 Stellite Faced
Yoke Sleeve	ASTM A439 - D2	ASTM A439 - D2	ASTM A439 - D2	ASTM A439 - D2
Handwheel	Cast Iron/Steel	Cast Iron/Steel	Cast Iron/Steel	Cast Iron/Steel
Disc	ASTM A216 Gr WCB Stellite Faced	ASTM A182 F11 Stellite Faced	ASTM A182 F22 Stellite Faced	ASTM A182 F91 Stellite Faced
Gland Packing	Flexible Graphite Rings	Flexible Graphite Rings	Flexible Graphite Rings	Flexible Graphite Rings
Pressure Seal Ring	Expanded Graphite	Expanded Graphite	Expanded Graphite	Expanded Graphite

† 0.25% Carbon max.

Hardfacing is stellite or equivalent



VALVE DIMENSIONS

Fig No. 5099, Butt Weld Ends, Class 2850

ASME Class 2850 FULL BORE											
Size mm	Fig No.	Weight lbs kgs	Length L	Casting OD		Valve Bore B	Withdrawal Space D2	Height Closed H	H/W Dia		K Factor
				DI	DI				W	W	
5	5099 - FB	427	20.98	5.39	3.15	54.76	41.57	30	424	1.35	
		194	533	137	80	1391	1056	762			
6		884	24.02	7.99	4.17	64.09	47.13	30	896	0.64	
		402	610	203	106	1628	1197	762			
8		1441	30.00	10.20	5.24	72.83	52.09	30	1171	1.40	
		655	762	259	133	1850	1323	762			
10		2266	35.98	12.09	6.57	92.17	67.64	36	1876	1.32	
		1030	914	307	167	2341	1718	914			
12		5181	40.98	13.98	8.27	109.49	78.58	36	3288	0.87	
		2355	1041	355	210	2781	1996	914			
14		6490	43.98	16.54	8.98	108.15	74.88	36	3755	0.99	
		2950	1117	420	228	2747	1902	914			
16		10424	49.02	17.17	10.28	136.02	97.60	36	4934	0.99	
		4738	1245	436	261	3455	2479	914			
18		14291	55.00	17.72	12.20	140.00	99.41	36	7809	0.63	
		6496	1397	450	310	3556	2525	914			
20		15286	60.00	18.78	12.99	145.00	103.66	36	8065	0.91	
		6948	1524	477	330	3683	2633	914			
24		17901	67.99	24.06	15.24	172.72	116.69	36	10618	1.10	
		8137	1727	611	387	4387	2964	914			

ASME Class 2850 STANDARD BORE											
Size mm	Fig No.	Weight lbs kgs	Length L	Casting OD		Valve Bore B	Withdrawal Space D2	Height Closed H	H/W Dia		K Factor
				DI	DI				W	W	
5	NA			NA							
6	5099 - PB	486	24.02	7.68	3.15	54.76	41.57	30	571	1.57	
		221	610	195	80	1391	1056	762			
8		972	30.00	9.06	4.17	64.09	47.13	30	936	2.19	
		442	762	230	106	1628	1197	762			
10		1753	35.98	12.17	5.24	72.83	52.09	30	1493	2.09	
		797	914	309	133	1850	1323	762			
12		2882	40.98	14.17	6.57	92.17	67.64	36	2480	1.52	
		1310	1041	360	167	2341	1718	914			
14		3828	43.98	14.17	7.05	86.02	59.45	24	2725	1.88	
		1740	1117	360	179	2185	1510	610			
16		5837	49.02	17.20	8.27	109.49	78.58	36	3855	1.62	
		2653	1245	437	210	2781	1996	914			
18		7506	55.00	19.80	8.98	108.15	74.88	36	4346	2.05	
		3412	1397	503	228	2747	1902	914			
20		11317	60.00	21.42	10.28	136.02	97.60	36	5904	1.70	
		5144	1524	544	261	3455	2479	914			
24		16254	67.99	29.29	12.20	140.00	99.41	36	8159	1.86	
		7388	1727	744	310	3556	2525	914			

ASME Class 2850 REDUCED BORE											
Size mm	Fig No.	Weight lbs kgs	Length L	Casting OD		Valve Bore B	Withdrawal Space D2	Height Closed H	H/W Dia		K Factor
				DI	DI				W	W	
5	NA			NA							
6	NA			NA							
8	5099 - RB	579	30.00	9.45	3.15	54.76	41.57	30	428	10.49	
		263	762	240	80	1391	1056	762			
10		1122	35.98	11.14	4.17	64.09	47.13	30	776	7.73	
		510	914	283	106	1628	1197	762			
12		1932	40.98	14.41	5.24	72.83	52.09	30	1261	5.89	
		878	1041	366	133	1850	1323	762			
14		3007	43.98	15.08	6.57	92.17	67.64	36	2212	2.85	
		1367	1117	383	167	2341	1718	914			
16		4085	49.02	17.09	7.05	86.02	59.45	24	2349	4.35	
		1857	1245	434	179	2185	1510	610			
18		6237	55.00	20.51	8.27	109.49	78.58	36	3398	3.35	
		2835	1397	521	210	2781	1996	914			
20		7922	60.00	20.71	8.98	108.15	74.88	36	3898	3.90	
		3601	1524	526	228	2747	1902	914			
24		12217	67.99	24.61	10.28	136.02	97.60	36	4792	5.40	
		5553	1727	625	261	3455	2479	914			



PRESSURE/TEMPERATURE RATINGS

High Pressure Cast Steel Pressure Seal Parallel Slide Gate Valve

ASME B16.34 (2004) Interpolated 1000, 1690 and 2850 Standard & Special Class Pressure/Temperature Ratings

Class 1000 Metric Units

Fig No	End Conn	ASTM Body Material	ASME B16.34 Class	-29 to								Working Pressure in barg								Temperature in °C				
				38	50	100	150	200	250	300	325	350	375	400	425	450	475	500	525	550	575	600	625	650
5095	BWE	WCB	1000 Standard	170.2	167.1	155.3	150.2	146.0	139.8	132.8	129.0	125.2	121.2	115.8	95.9	76.7*	-	-	-	-	-	-	-	-
5095XR	BWE	WCB	1000 Special	172.4	172.4	172.1	170.1	168.6	168.4	168.4	167.0	163.0	157.0	144.7	119.9	95.9*	-	-	-	-	-	-	-	-
L5095	BWE	WC6	1000 Standard	172.4	172.4	171.6	165.8	159.9	154.5	142.9	137.8	134.1	129.4	122.0	116.8	112.7	105.6	85.8	49.7	42.3	29.3	20.3	-	-
L5095XR	BWE	WC6	1000 Special	172.4	172.4	172.4	172.4	172.4	172.4	172.4	172.4	171.4	168.3	167.4	165.5	159.2	142.5	107.2	62.0	53.0	36.7	25.5	-	-
R5095	BWE	WC9	1000 Standard	172.4	172.4	171.8	167.3	162.1	154.5	142.9	137.8	134.1	129.4	122.0	116.8	112.7	105.6	94.1	61.5	52.1	35.0	23.0	-	-
R5095XR	BWE	WC9	1000 Special	172.4	172.4	172.1	169.9	167.4	166.6	165.9	165.3	164.0	162.6	162.6	162.6	157.1	142.5	119.0	76.8	65.1	43.9	28.7	-	-
U5095	BWE	C12A	1000 Standard	172.4	172.4	171.8	167.3	162.1	154.5	142.9	137.8	134.1	129.4	122.0	116.8	112.7	105.6	94.1	83.6	83.2	79.8	65.0	48.7	33.1
U5095XR	BWE	C12A	1000 Special	172.4	172.4	172.4	172.4	172.4	172.4	172.4	172.4	171.4	168.3	167.4	165.5	159.2	142.5	119.0	96.6	96.6	95.3	81.2	60.9	41.4

Class 1690 Metric Units

Fig No	End Conn	ASTM Body Material	ASME B16.34 Class	-29 to								Working Pressure in barg								Temperature in °C				
				38	50	100	150	200	250	300	325	350	375	400	425	450	475	500	525	550	575	600	625	650
5096	BWE	WCB	1690 Standard	287.6	282.3	262.5	253.9	246.7	236.3	224.3	218.1	211.6	204.8	195.6	162.0	129.6*	-	-	-	-	-	-	-	-
5096XR	BWE	WCB	1690 Special	291.3	291.3	290.9	287.5	284.9	284.6	284.6	282.3	275.6	265.3	244.5	202.6	162*	-	-	-	-	-	-	-	-
L5096	BWE	WC6	1690 Standard	291.3	291.3	290.0	280.2	270.2	261.1	241.5	232.8	226.6	218.6	206.2	197.2	190.4	178.3	144.9	83.9	71.6	49.6	34.4	-	-
L5096XR	BWE	WC6	1690 Special	291.3	291.3	291.3	291.3	291.3	291.3	291.3	291.3	289.7	284.5	282.9	279.6	265.7	240.8	181.2	104.9	89.5	62.0	43.0	-	-
R5096	BWE	WC9	1690 Standard	291.3	291.3	290.2	282.6	274.2	261.1	241.5	232.8	226.6	218.6	206.2	197.2	190.4	178.3	158.8	103.9	88.1	59.3	38.8	-	-
R5096XR	BWE	WC9	1690 Special	291.3	291.3	290.8	287.1	282.9	281.6	280.4	279.4	277.2	274.7	274.7	274.7	265.7	240.8	201.2	129.8	110.1	74.1	48.5	-	-
U5096	BWE	C12A	1690 Standard	291.3	291.3	290.2	282.6	274.2	261.1	241.5	232.8	226.6	218.6	206.2	197.2	190.4	178.3	158.8	141.3	140.7	134.9	109.9	82.3	55.9
U5096XR	BWE	C12A	1690 Special	291.3	291.3	291.3	291.3	291.3	291.3	291.3	291.3	289.7	284.5	282.9	279.6	265.7	240.8	201.2	163.5	163.5	161.1	137.3	102.9	69.9

Class 2850 Metric Units

Fig No	End Conn	ASTM Body Material	ASME B16.34 Class	-29 to								Working Pressure in barg								Temperature in °C				
				38	50	100	150	200	250	300	325	350	375	400	425	450	475	500	525	550	575	600	625	650
5099	BWE	WCB	2850 Standard	485.1	476.2	442.7	428.2	416.1	398.4	378.3	367.8	356.8	345.5	329.8	273.3	218.5*	-	-	-	-	-	-	-	-
5099XR	BWE	WCB	2850 Special	491.2	491.2	490.5	484.8	480.4	480.0	480.0	471.6	464.7	447.5	412.3	341.5	273.2*	-	-	-	-	-	-	-	-
L5099	BWE	WC6	2850 Standard	491.2	491.2	489.1	472.5	455.6	440.2	407.1	392.5	382.2	368.5	347.5	332.4	321.2	300.8	244.4	141.5	120.7	83.7	58.0	-	-
L5099XR	BWE	WC6	2850 Special	491.2	491.2	491.2	491.2	491.2	491.2	491.2	491.2	488.6	479.8	476.9	471.6	448.1	406.2	305.5	176.8	150.9	104.5	72.5	-	-
R5099	BWE	WC9	2850 Standard	491.2	491.2	489.5	476.8	462.2	440.2	407.1	392.5	382.2	368.5	347.5	332.4	321.2	300.8	267.9	175.2	148.5	100.0	65.4	-	-
R5099XR	BWE	WC9	2850 Special	491.2	491.2	490.4	484.0	477.1	474.8	472.9	471.2	467.4	463.2	463.2	463.2	448.1	406.2	339.1	219.0	185.6	125.0	81.7	-	-
U5099	BWE	C12A	2850 Standard	491.2	491.2	489.5	476.8	462.2	440.2	407.1	392.5	382.2	368.5	347.5	332.4	321.2	300.8	267.9	238.1	237.1	227.4	185.3	138.7	94.3
U5099XR	BWE	C12A	2850 Special	491.2	491.2	491.2	491.2	491.2	491.2	491.2	491.2	488.6	479.8	476.9	471.6	448.1	406.2	339.1	275.5	275.5	271.6	231.5	173.4	117.9

* Use of WCB is permissible, but not recommended for prolonged use above 425°F
WC6 and WC9 are not to be used above 595 °F

For intermediate ratings use linear interpolation



PRESSURE/TEMPERATURE RATINGS

High Pressure Cast Steel Pressure Seal Parallel Slide Gate Valve

ASME B16.34 (2004) Interpolated 1000, 1690, and 2850 Standard & Special Class Pressure/Temperature Ratings

Class 1000 Imperial Units

Fig No	End Conn	ASTM Body Material	ASME B16.34 Class	-20 to		Working Pressure in psig								Temperature in °F							
				100	200	300	400	500	600	650	700	750	800	850	900	950	1000	1050	1100	1150	1200
5095	BWE	WCB	1690 Standard	2468	2262	2183	2112	2011	1894	1833	1769	1689	1372	1062*	-	-	-	-	-	-	
5095XR	BWE	WCB	1690 Special	2500	2500	2467	2444	2444	2444	2383	2305	2116	1716	1328*	-	-	-	-	-	-	
L5095	BWE	WC6	1690 Standard	2500	2500	2406	2311	2217	2017	1961	1894	1773	1694	1623	1499	1062	722	478	322	-	-
L5095XR	BWE	WC6	1690 Special	2500	2500	2500	2500	2500	2500	2500	2444	2428	2400	2256	1956	1328	900	600	400	-	-
R5095	BWE	WC9	1690 Standard	2500	2500	2428	2351	2217	2017	1961	1894	1773	1694	1623	1499	1288	889	583	367	-	-
R5095XR	BWE	WC9	1690 Special	2500	2500	2449	2428	2416	2405	2384	2356	2356	2256	2000	1573	1116	728	456	-	-	-
U5095	BWE	C12A	1690 Standard	2500	2500	2428	2351	2217	2017	1961	1894	1773	1694	1623	1499	1288	1212	1200	1006	744	478
U5095XR	BWE	C12A	1690 Special	2500	2500	2500	2500	2500	2500	2500	2444	2428	2400	2256	2000	1573	1401	1401	1256	928	600

Class 1690 Imperial Units

Fig No	End Conn	ASTM Body Material	ASME B16.34 Class	-20 to		Working Pressure in psig								Temperature in °F							
				100	200	300	400	500	600	650	700	750	800	850	900	950	1000	1050	1100	1150	1200
5096	BWE	WCB	1690 Standard	4173	3824	3684	3571	3397	3199	3093	2999	2857	2316	1796*	-	-	-	-	-	-	
5096XR	BWE	WCB	1690 Special	4225	4225	4169	4137	4137	4137	4028	3893	3572	2896	2247*	-	-	-	-	-	-	
L5096	BWE	WC6	1690 Standard	4225	4225	4067	3904	3746	3408	3313	3199	2996	2861	2744	2530	1796	1217	811	541	-	-
L5096XR	BWE	WC6	1690 Special	4225	4225	4225	4225	4225	4225	4225	4130	4106	4056	3814	3307	2247	1521	1014	676	-	-
R5096	BWE	WC9	1690 Standard	4225	4225	4102	3977	3746	3408	3313	3199	2996	2861	2744	2530	2175	1505	985	619	-	-
R5096XR	BWE	WC9	1690 Special	4225	4225	4163	4101	4079	4062	4033	3983	3983	3983	3814	3380	2658	1882	1233	772	-	-
U5096	BWE	C12A	1690 Standard	4225	4225	4102	3977	3746	3408	3313	3199	2996	2861	2744	2530	2175	2050	2028	1701	1256	811
U5096XR	BWE	C12A	1690 Special	4225	4225	4225	4225	4225	4225	4225	4130	4106	4056	3814	3380	2658	2371	2371	2124	1571	1014

Class 2850 Imperial Units

Fig No	End Conn	ASTM Body Material	ASME B16.34 Class	-20 to		Working Pressure in psig								Temperature in °F							
				100	200	300	400	500	600	650	700	750	800	850	900	950	1000	1050	1100	1150	1200
5099	BWE	WCB	2850 Standard	7035	6448	6214	6019	5728	5392	5216	5044	4822	3910	3028*	-	-	-	-	-	-	
5099XR	BWE	WCB	2850 Special	7125	7125	7034	6961	6961	6961	6795	6566	6025	4885	3786*	-	-	-	-	-	-	
L5099	BWE	WC6	2850 Standard	7125	7125	6858	6584	6314	5745	5591	5392	5050	4822	4628	4269	3028	2052	1368	912	-	-
L5099XR	BWE	WC6	2850 Special	7125	7125	7125	7125	7125	7125	7125	6965	6921	6840	6435	5579	3786	2565	1710	1140	-	-
R5099	BWE	WC9	2850 Standard	7125	7125	6920	6703	6314	5745	5591	5392	5050	4822	4628	4269	3671	2542	1660	1214	-	-
R5099XR	BWE	WC9	2850 Special	7125	7125	7023	6914	6880	6851	6800	6719	6719	6719	6435	5700	4480	3175	2076	1304	-	-
U5099	BWE	C12A	2850 Standard	7125	7125	6920	6703	6314	5745	5591	5392	5050	4822	4628	4269	3671	3448	3420	2869	2116	1368
U5099XR	BWE	C12A	2850 Special	7125	7125	7125	7125	7125	7125	7125	6965	6921	6840	6435	5700	4480	4129	4129	3584	2646	1710

* Use of WCB is permissible, but not recommended for prolonged use above 800°F
 WC6 and WC9 are not to be used above 1100°F

For intermediate ratings use linear interpolation



DISTRIBUTED BY



HH VALVES LTD

UNIT 4, LEOPOLD CENTRE, SMETHURST LANE

PEMBERTON, WIGAN WN5 8EG

TELEPHONE: +44 (0)1942 218 111 FAX: +44 (0)1942 224 800

EMAIL: sales@hhvalves.com WEB: www.hhvalves.com

Our policy is one of continuous development and improvement and we therefore retain the right to alter specifications at any time and without notice. Every effort is made to produce up-to-date literature but this brochure should not be regarded as an infallible guide to current specification and does not form part of any contract.