

rotork® Controls

Marine Navy Applications

In a world where operability and reliability are of paramount importance, the IQT-N actuator builds upon the success of the original IQT actuator.

Specifically designed to meet the needs of modern warship design, the IQT-N has been independently tested for shock tolerance and meets the requirements of most worldwide surface ship applications.

Size and weight implications have been addressed by providing a compact design, packed with features and benefits normally found on additional equipment.

The Rotork IQT-N actuator offers a low cost, reliable, virtually maintenance free, light weight 'fit and forget' solution which offers a myriad of control options fitting with the management of shipboard critical systems.

Various optional upgrades are available including:

- Fire protection exceeding ANSI/API607 and UL1709 (1,093 °C / 2,000 °F for 30 minutes)*

IQ-Insight PC software, when used in conjunction with the Setting Tool *Pro*, allows all IQ set-up configuration and data logger information to be transferred to a PC, reviewed analysed and reconfigured. Reconfigured files can then be uploaded to the actuator.

IQT-N offers the following powerful features

- Three-phase, single-phase and DC power supplies.
- Modulating duty option.
- Full-turn and multiport option.
- Shock tolerant.
- Compact design.
- Environmental protection to IP68 (7 mtr for 72 hours).

Setting Tool *Pro* features

- Stores downloaded data for analysis with InSight software on PC's.
- Fast, easy configuration of multiple actuators on-board using transferable settings feature.
- Intrinsically safe robust construction.

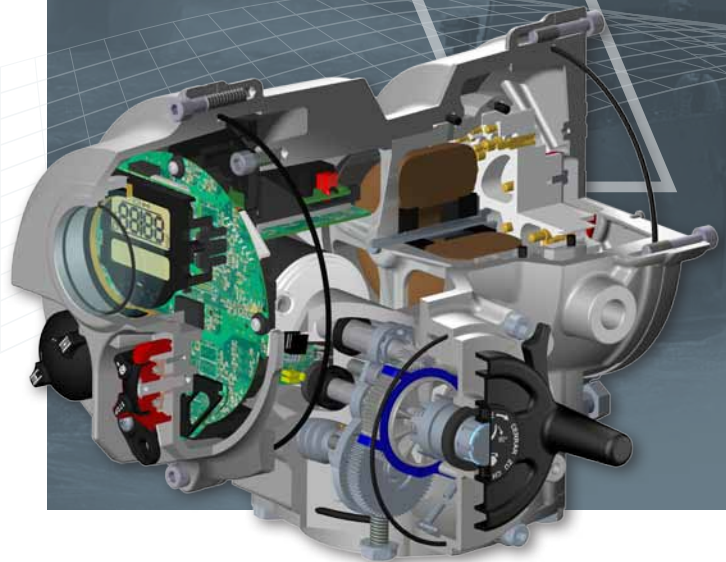

IQT-N Range

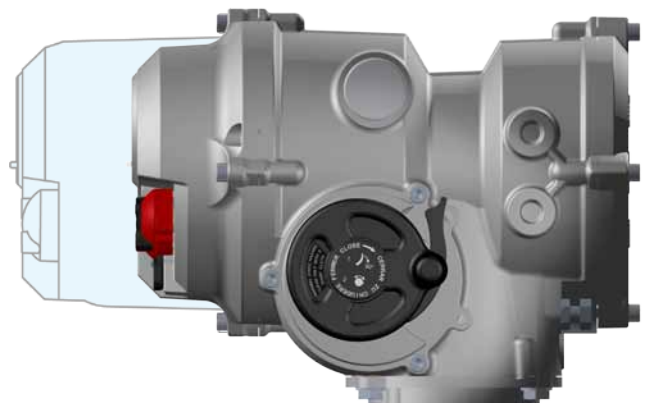

ACTUATOR	MAXIMUM TORQUE
IQT-N125	125 Nm / 92 Ft lbs
IQT-N250	250 Nm / 185 Ft lbs
IQT-N500	500 Nm / 369 Ft lbs
IQT-N1000	1,000 Nm / 738 Ft lbs
IQT-N2000	2,000 Nm / 1,476 Ft lbs

* Please consult Rotork for various options such as semi-rigid enclosures (blankets). Intumescent coating is not available for this product.

Established Leaders in Actuation Technology

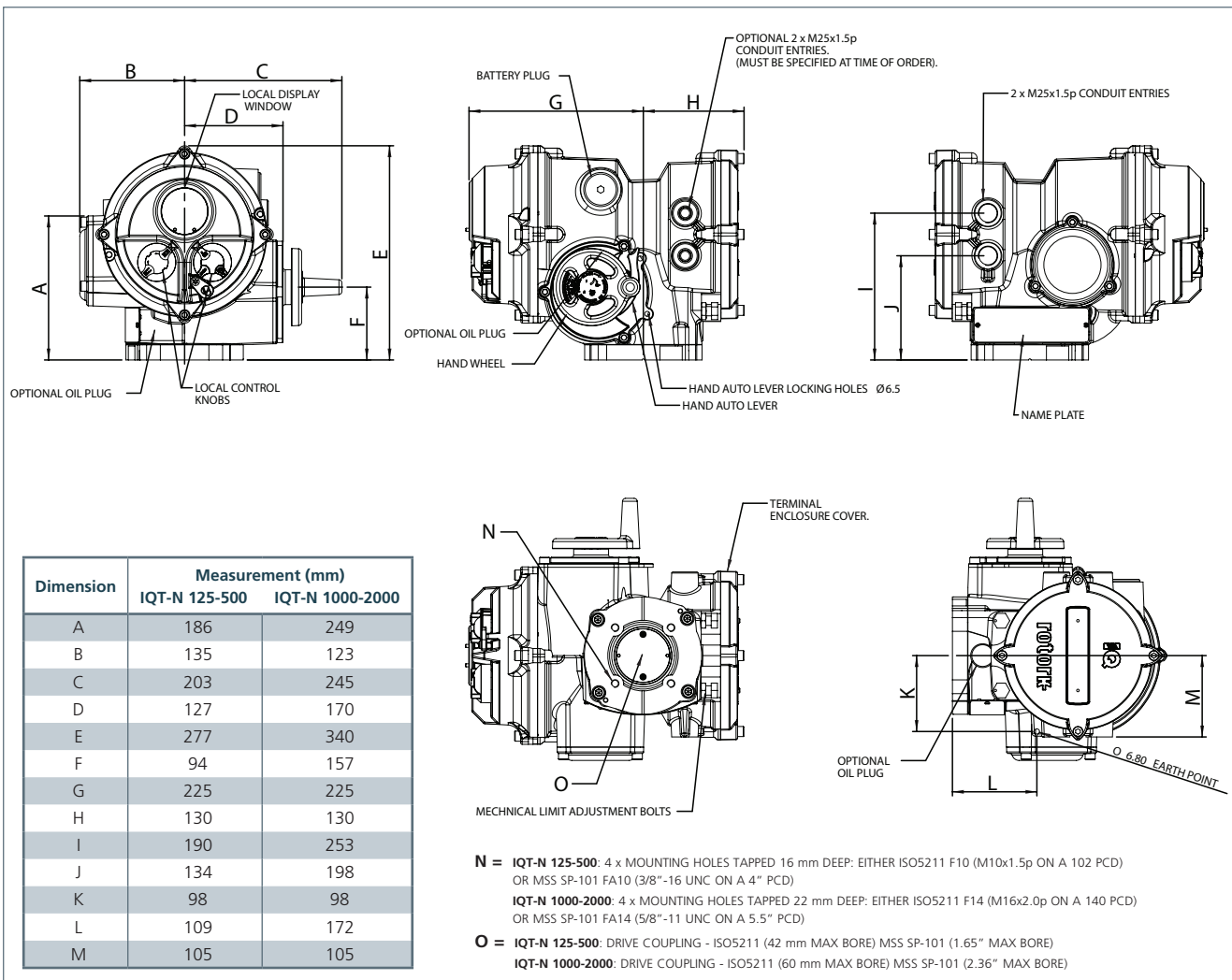

A full listing of our worldwide sales and service network is available on our website.

www.rotork.com

UK
 Rotork plc
 tel +44 (0)1225 733200
 fax +44 (0)1225 333467
 email mail@rotork.com

USA
 Rotork Controls Inc.
 tel +1 (585) 247 2304
 fax +1 (585) 247 2308
 email info@rotork.com

Controls
 Electric Actuators and Control Systems

Fluid Systems
 Fluid Power Actuators and Control Systems

Gears
 Gearboxes and Gear Operators

Site Services
 Projects, Services and Retrofit