

Forged & Cast Steel
Ball Valves

1/2" to 60"



FLUICON



Ball Valves

Side entry

Top entry

All welded

Metal to metal

Cryogenic

API 6A

API 6D

Sub Sea

Modular

C-BV5





A family tradition:
50 years and counting
Roberto Brevi
Simone Brevi
e Fabio Brevi

www.ombvalves.com

Introduction 3	API 6A 26
Quality - Testing 4	Product Range 28
Trunnion - Programme/Features 6	Floating - Programme/ Features 30
Side entry - BSE 8	Floating 32
Forged and cast top entry - BTE 14	Cryogenic 36
Full welded - WSE 20	Modular Valves 39

INTRODUCTION

Over the past 30 years OMB have developed into a major international valve supplier, supporting the oil, gas, power generation & chemical industries. We have gained a reputation for quality and reliability and OMB's innovation is supported by a rigorous Research & Development Programme.

OMB are always looking to develop existing products and introduce new lines, which will enable the company to strengthen its market share and take OMB into the next millennium.

OMB work in close liaison with their customers, helping in identifying and solving problems and this is supported by a network of valve distribution and marketing service offices. Recently OMB acquired the Lamperti range of Ball Valve Products, which will further expand upon our existing range of ball valves. Due to this expansion programme we have opened a new Ball Valve Division "Fluicon", solely specialising in the manufacture and development of the ball valves range.

The valves will be fully in accordance with API6D and BS 5351. The valves are firesafe certified and manufactured in soft or metal seated designs. They can also be supplied Top Entry or Split Body welded construction. They can be manufactured to work at low temperature conditions and high temperatures.

With the total commitment of OMB, this new division can only be successful and we look forward to working with all our existing customers and new ones in the future, guaranteeing the OMB technical excellence and reliability.

OMB div Fluicon. Headquarter in Bergamo, Italy



QUALITY

OMB's certified quality assurance system is the result of more than 25 years of experience as forged steel valve manufacturers.



Each phase in the engineering, design, order administration manufacturing, procurement and assembly, as well as servicing the valves in the field, is ruled by comprehensive procedures.

OMB is certified to ISO 9001 since July 1990 and the strict application of very high quality assurance procedures won OMB the approval by the most important end-users around the world.

All the necessary quality assurance measures are put into practice and then documented from the time the order is received until the delivery time.

OMB staff has extensive experience in operating under strict quality standards, thus guaranteeing high level of service throughout all the company activities.



OMB spa-CENATE-BG-Italy-Fax +39+35+4256710		
valves specialist		
		
API LIC. Nr. 6D-0286		
		
FIG.		
OMB CODE		
SIZE	API CLASS	
RATING at 100°F	psi/MOP	
BODY	STEM	BALL
SEAT & INS.		
SERIAL Nr.		
TAG. N°		
M/YEAR		

All OMB Ball Valves can be recognized by the tag reporting all the relevant valve information.



TESTING



HYDRAULIC TEST



GAS TEST



FIRE SAFE TEST

Severe testing and inspection of all product components ensure the high quality and reliability of OMB-FLUICON ball valves.

Coordinate measurement equipment certifies the precision of valve components to required finish tolerances.

Valve performance are then tested against the OMB-FLUICON testing procedures. Every valve is pressure tested to assure the integrity of its construction before being released to the customer.

Special testing procedures can be studied and applied to meet specific customer's request.

Starting from material and components evaluation, OMB's Quality Control division operates a *state-of-the-art* laboratory where valves can be tested to satisfy every customer's requisition.

The laboratory is equipped to operate the following tests; just to mention few:

- Cryogenic Test
- Gas test
- Leak test
- Bend test
- DPI and MPI
- Fire safe test
- P.A.M.I. and other material related tests. All tests are documented and certified according to internal procedures based on international requirements or customer's requisitions.

	APPROVAL CERTIFICATE	n° M7654/C	Page 1 / 1
	Ref. BV.ITA.: 40.96.7654		
FIRE SAFE TEST ACC. TO API 607-65 6755			
Client : OMB SPA		Inspection date: 04.11.96	
<p>The undersigned ALDO NICOLINI, Supervisor of BUREAU VERITAS, acting within the scope of the general conditions which regulate the interventions of our company, did attend at request of Messrs. OMB SPA CINATE SOTTO - BERGAMO to their works for the purpose of witnessing the Fire Safe Test according to API 607-1988 and BS 6755 PART 2:1987 on the following valve:</p>			
Valve Description			
<p>Ball Side Entry RSE Trunion Valve 900 Lbs. Flanged Stock Finish size 8 x 4" Industrial Size Material Body-Closure : ASTM A105N + ENP Material Seat : ASTM A182 F8a Class 2 + ENP Material Stem : ASTM A193N + ENP Material Ball : ASTM A182 F8a Class 2</p>			
Manufactured and assembled in accordance with OMB drawing no. A9004-900			
<p>The valve was exposed to fire for 30 minutes, and during the test all parameters, as required by API 607 and BS6755 Part 2, were checked, recorded and found according to STD requirements. For further details of test arrangements and test results, see OMB Certificate no. 1569 herewith attached and duly enclosed.</p>			
ON THE BASIS OF THE RESULTS, THE ABOVE BALL VALVE SATISFACTORILY PASSED THE " FIRE SAFE TEST. "			
Date:	04.11.96	Issued by:	ALDO NICOLINI
BV STAMP:		Inspector:	MILANO
		Distribution:	
		BY Client:	

Fire Safe Certification



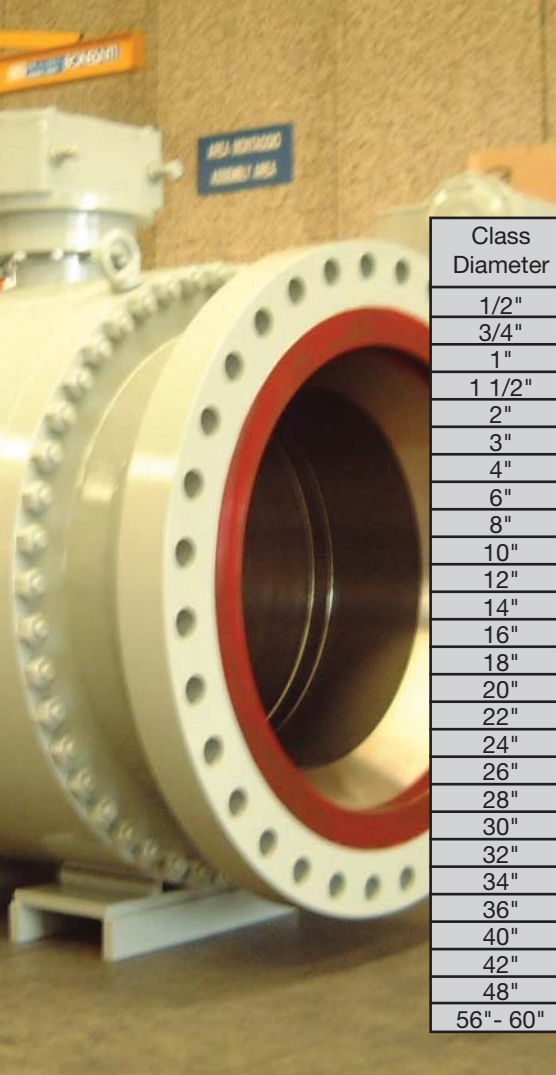

Trunnion Construction

Class Diameter	Class 150 RB - FB		Class 300 RB - FB		Class 600 RB - FB		Class 900 RB - FB		Class 1500 RB - FB		Class 2500 RB - FB	
1/2"												
3/4"												
1"												
1 1/2"												
2"	●	○	●	○	●	○	●	○	●	○	●	○
3"	●	○	●	○	●	○	●	○	●	○	●	○
4"	●	○	●	○	●	○	●	○	●	○	●	○
6"	●	○	●	○	●	○	●	○	●	○	●	○
8"	●	○	●	○	●	○	●	○	●	○	●	○
10"	●	○	●	○	●	○	●	○	●	○	●	○
12"	●	○	●	○	●	○	●	○	●	○	●	○
14"	●	○	●	○	●	○	●	○	●	○	●	○
16"	●	○	●	○	●	○	●	○	●	○	●	○
18"	●	○	●	○	●	○	●	○	●	○	●	○
20"	●	○	●	○	●	○	●	○	●	○	●	○
22"		○		○		○		○				
24"	●	○	●	○	●	○	●	○	●	○		
26"		○		○		○						
28"		○		○		○		○				
30"	●	○	●	○	●	○	●	○				
32"		○		○		○		○				
34"		○		○		○		○				
36"	●	○	●	○	●	○	●	○				
40"		○		○		○						
42"		○		○		○						
48"		○		○		○						
56" - 60"		○		○		○						

Other dimension on request

PROGRAMME



Applicable Standards

BS 5351

Steel Ball Valves

BS 6755

Testing of Valves

API 6D LICENCE N° 6D-0286

Specification for pipeline valves

API 6A LICENCE N° 6A-0778

Specification wellhead valves

API Spec. Q1

Quality

API 607

Valve Insp. Test

API 598

Steel Ball Valves

ISO 9001

Specification for Q.A.

ASME/ANSI B16.10

Face-to-face and End-to-end dimensions on ferrous valves

ASME/ANSI B16.5 - B16.47

Pipe flanges and flanged fittings

ASME/ANSI B16.34

Valves-flanged and Buttweld end

MSS SP-25

Standard Marking system for valves

NACE std MRO175

Sulfide stress cracking resistant metallic materials for oilfield equipment



OMB-FLUICON side entry type Ball Valves

OMB-FLUICON trunnion mounted type ball valves are manufactured to API 6D specification and tested to API 598/API 607. The construction is side entry three pieces full and reduced port. The valves are lever operated and where recommended or when required are gear operated or actuated. The following are some of the major design features:

Structure: Solid entirely forged construction.

Fire-safe: All size and pressure classes have been successfully fire-safe tested according to the relevant API and BS specifications. Test certificates are available on request.

Antistatic: Electrical continuity of all valve components, prevent statics build-up.

Double Block & Bleed: The body cavity is isolated when the ball is in either fully closed or fully opened position, the medium entrapped in it can easily be bled to avoid overpressure.

Seat Ring Sealing: as line pressure increases, our seat design enacts a piston effect forcing the resilient seat insert against the ball. In absence of the pressure or with low pressures, the seats are forced against the ball by the set of preloaded springs. (see sketch)

Pressure relieving: If excessive pressure builds up in the body cavity exceeding the safe working pressure, the seat automatically relieves.



FEATURES

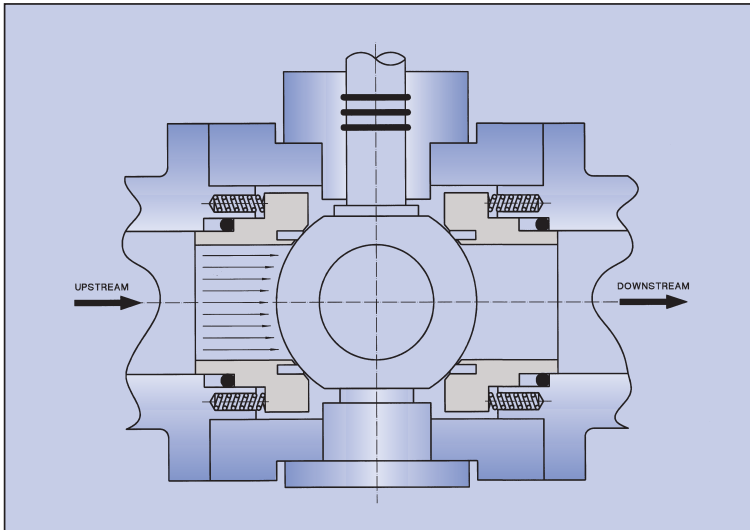

Trunnion Construction

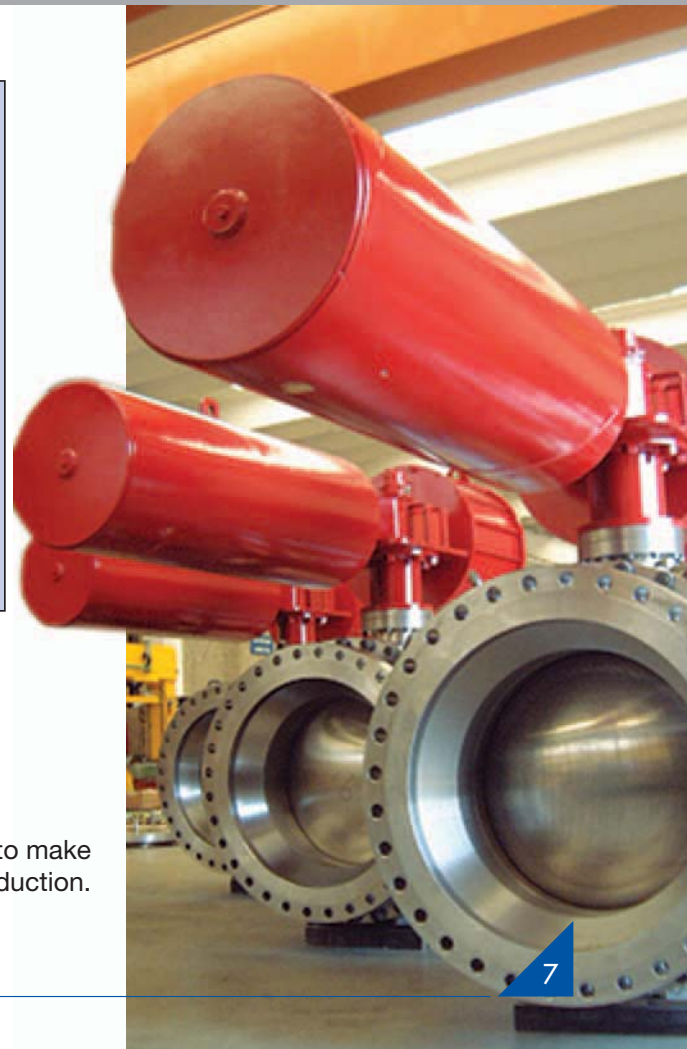

Without prior notice OMB reserves the right to make modifications or changes to its production.





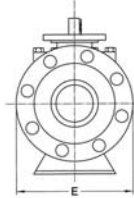
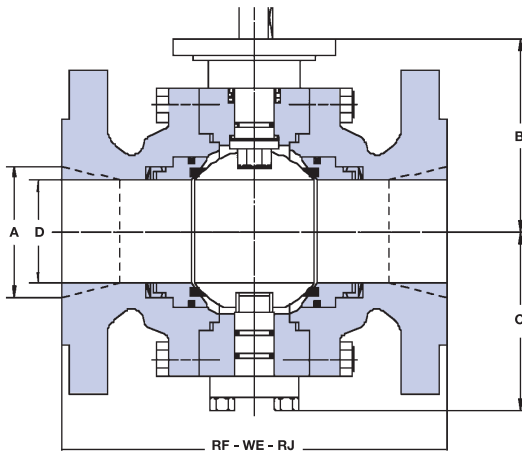

JASME CLASS 150 FULL BORE

SIZE IN/MM	SIDE ENTRY						WEIGHT LB/KG
	D	RF	WE	E	B	C	
2	2.00	7.00	8.50	5.90	5.51	3.54	44
50	51	178	216	150	140	90	20
3	3.00	8.00	11.13	7.48	7.48	4.13	91
80	76	203	283	190	190	105	41
4	4.00	9.00	12.00	9.00	9.72	5.55	144
100	102	229	305	230	247	141	65
6	6.00	15.50	18.00	12.20	11.61	6.88	338
150	152	394	457	310	295	175	152
8	8.00	18.00	20.50	15.35	12.99	8.26	489
200	203	457	521	390	330	210	220
10	10.00	21.00	22.00	18.11	15.74	9.84	922
250	254	533	559	460	400	250	415
12	12.00	24.00	25.00	21.45	18.11	12.20	1289
300	305	610	635	545	460	310	580
14	14.00	27.00	30.00	24.00	18.89	13.38	1802
350	356	686	762	610	480	340	811
16	16.00	30.00	33.00	26.37	21.25	15.15	2644
400	406	762	838	670	540	385	1150
18	18.00	34.00	36.00	24.80	22.83	16.85	2888
450	457	864	914	630	580	428	1300
20	20.00	36.00	39.00	33.43	23.00	21.45	4000
500	508	914	991	849	584	545	1800
22	22.00	40.00	43.00	36.81	24.00	23.00	5333
550	559	991	1092	935	610	584	2400
24	24.00	42.00	45.00	39.57	24.10	25.87	6888
600	610	1067	1143	1005	612	655	3100
26	26.00	45.00	49.00	41.73	24.69	22.20	(1)
650	660	1143	1245	1060	627	564	(1)
28	28.00	49.00	53.00	44.88	25.35	25.91	(1)
700	711	1244	1347	1140	644	658	(1)
30	30.00	51.00	55.00	47.24	27.20	27.70	(1)
750	762	1295	1397	1200	691	705	(1)
32	32.00	54.00	60.00	51.18	29.21	29.37	(1)
800	813	1371	1524	1300	742	746	(1)
34	34.00	58.00	64.00	53.94	29.88	30.51	(1)
850	864	1473	1626	1370	759	775	(1)
36	36.00	60.00	68.00	56.30	31.97	31.77	(1)
900	914	1524	1728	1430	812	807	(1)
40	40.00	69.00	77.00	63.00	35.43	35.35	(1)
1000	1016	1753	1956	1600	900	898	(1)
42	42.00	72.00	82.00	64.96	37.13	37.00	(1)
1050	1067	1855	2083	1656	943	940	(1)
48	48.00	80.00	94.00	75.59	43.19	41.73	(1)
1200	1219	2134	2388	1920	1097	1060	(1)
56	53.54	98.00	98.00	89.00	52.00	50.00	(1)
1400	1360	2490	2490	2260	13.21	1270	(1)

With lever
With gear

ASME CLASS 150 REDUCED BORE

SIZE IN/MM	SIDE ENTRY							WEIGHT LB/KG
	A	D	RF	WE	E	B	C	
2 x 1/2	2.00	1.50	7.00	8.50	5.90	4.00	3.00	33
50 x 40	51	38	178	216	150	101	76	15
3 x 2	3.00	2.00	11.13	3.03	7.48	5.51	3.54	66
80 x 50	76	51	203	283	190	140	90	30
4 x 3	4.00	3.00	12.00	4.02	9.00	7.48	4.13	133
100 x 80	102	76	229	305	230	190	105	60
6 x 4	6.00	4.00	15.50	18.00	12.20	11.02	6.53	262
150 x 100	152	102	394	457	310	280	166	118
8 x 6	8.00	6.00	18.00	20.50	15.35	11.61	6.88	366
200 x 150	203	152	457	521	395	295	175	165
10 x 8	10.00	8.00	21.00	22.00	15.98	12.99	8.26	588
250 x 200	254	203	533	559	406	330	210	265
12 x 10	12.00	10.00	24.00	25.00	19.02	15.74	9.84	1000
300 x 250	305	254	610	635	483	400	250	450
14 x 10	14.00	10.00	27.00	30.00	21.06	18.11	12.30	1155
350 x 250	356	254	686	762	535	460	310	520
14 x 12	14.00	12.00	27.00	30.00	21.06	18.11	12.20	1577
350 x 300	356	305	686	762	535	460	310	710
16 x 12	16.00	12.00	30.00	33.00	23.43	18.89	13.38	1755
400 x 300	406	305	762	838	595	480	340	790
16 x 14	16.00	14.00	30.00	33.00	23.43	18.89	13.38	2000
400 x 350	406	356	762	838	595	480	340	900
18 x 16	18.00	16.00	34.00	36.00	24.80	21.25	15.15	2777
450 x 400	457	406	864	914	630	540	385	1250
20 x 16	20.00	16.00	36.00	39.00	27.56	22.83	16.85	1555
500 x 400	508	406	914	991	700	580	428	1150
20 x 18	20.00	18.00	36.00	39.00	27.56	22.83	16.85	2777
500 x 450	508	457	914	991	700	580	428	1250
24 x 20	24.00	20.00	42.00	45.00	32.28	23.00	18.00	6400
600 x 500	610	508	1067	1143	820	584	457	2990
28 x 24	28.00	24.00	49.00	53.00	37.40	24.50	19.49	(1)
700 x 600	711	610	1244	1347	950	622	495	(1)
30 x 24	30.00	24.00	51.00	55.00	38.78	25.15	20.28	(1)
750 x 600	762	610	1295	1397	985	638	515	(1)
36 x 30	36.00	30.00	60.00	68.00	46.06	27.17	27.56	(1)
900 x 750	914	762	1524	1728	1170	690	700	(1)

* Other dimension on request.

- Flanges in accordance with ASME B16.5
- Shaded bore sizes (D) according to API 6D

- Butt welding ends according to ASME B16.25
- Shaded end-to-end dimensions to API 6D

Weight figures are relevant to flanged end valves. (1) Please consult the factory. Note. For dimensions and weights in larger sizes consult the factory. Dimensions B, C, D, E and weights are subject to change without notice.



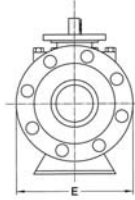
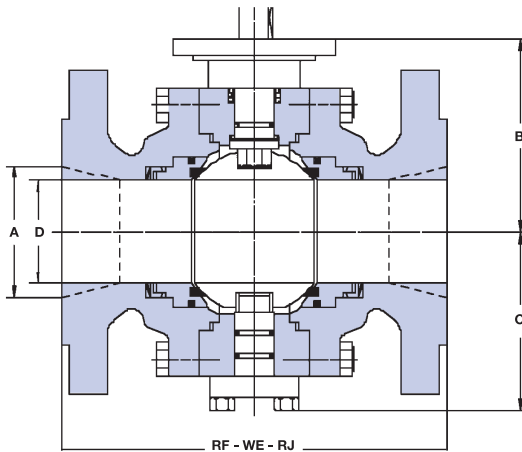

ASME CLASS 300 FULL BORE

SIZE IN/MM	SIDE ENTRY						WEIGHT LBS/KG
	D	RF	WE	E	B	C	
2	2.00	8.50	8.50	6.50	7.87	4.72	91
50	51	216	216	165	200	120	41
3	3.00	11.10	11.10	8.50	9.44	5.11	133
80	76	283	283	218	240	130	60
4	4.00	12.00	12.00	10.00	9.72	5.55	222
100	102	305	305	254	247	141	100
6	6.00	15.90	18.00	12.20	11.61	6.88	395
150	152	403	457	310	295	175	178
8	8.00	19.80	20.50	15.40	12.99	8.26	422
200	203	502	521	390	330	210	190
10	10.00	22.40	22.00	18.50	16.53	10.62	1066
250	254	568	559	470	420	270	480
12	12.00	25.50	25.00	21.30	18.30	12.79	1444
300	305	648	635	545	465	325	650
14	14.00	30.00	30.00	24.80	21.45	16.92	1777
350	356	762	762	630	545	430	800
16	16.00	33.00	33.00	27.20	23.62	18.50	2977
400	406	838	838	690	600	470	1340
18	18.00	36.00	36.00	30.30	23.10	20.07	3511
450	457	914	914	770	586	510	1580
20	20.00	39.00	39.00	33.50	23.90	19.68	6000
500	508	991	991	850	607	500	2200
22	22.00	43.00	43.00	37.00	24.10	21.00	6222
550	559	1092	1092	940	612	533	2800
24	24.00	45.00	45.00	39.70	24.50	23.62	8000
600	610	1143	1143	1010	622	600	3600
26	26.00	49.00	49.00	42.50	24.80	22.80	(1)
650	660	1245	1245	1080	630	580	(1)
28	28.00	53.00	53.00	45.30	25.20	26.60	(1)
700	711	1346	1346	1150	640	675	(1)
30	30.00	55.00	55.00	48.40	27.60	28.70	(1)
750	762	1397	1397	1230	700	730	(1)
32	32.00	60.00	60.00	52.00	29.30	29.90	(1)
800	813	1524	1524	1320	745	760	(1)
34	34.00	64.00	64.00	54.50	29.90	31.50	(1)
850	864	1626	1626	1380	760	800	(1)
36	36.00	68.00	68.00	56.9	31.70	32.5	(1)
900	914	1727	1727	1445	805	825	(1)
40	40.00	77.00	77.00	64.10	35.40	36.2	(1)
1000	1016	1956	1956	1630	900	920	(1)
42	42.00	82.00	82.00	66.90	38.10	38.40	(1)
1050	1067	2083	2083	1700	968	980	(1)
48	48.00	85.40	85.40	74.80	43.30	45.60	(1)
1200	1219	2170	2170	1960	1100	1160	(1)
56	53.54	108.00	108.00	89.00	50.00	50.00	(1)
1400	1360	2743	2743	2260	1270	1270	(1)

With lever
With gear

ASME CLASS 300 REDUCED BORE

SIZE IN/MM	SIDE ENTRY						WEIGHT LBS/KG	
	A	D	RF	WE	E	B		C
2 x 1 1/2	2.00	1.50	8.50	8.50	6.50	6.88	3.14	44
50 x 40	51	38	216	216	165	175	80	20
3 x 2	3.00	2.00	11.10	11.10	8.50	7.87	4.72	122
80 x 50	76	51	283	283	218	200	120	55
4 x 3	4.00	3.00	12.00	12.00	10.00	9.44	5.11	153
100 x 80	102	76	305	305	254	240	130	69
6 x 4	6.00	4.00	15.90	18.00	12.20	11.02	5.90	260
150 x 100	152	102	403	457	310	280	150	117
8 x 6	8.00	6.00	19.80	20.50	15.40	11.61	6.88	433
200 x 150	203	152	502	521	390	295	175	195
10 x 8	10.00	8.00	22.40	22.00	17.50	12.99	8.26	722
250 x 200	254	203	568	559	445	330	210	325
12 x 10	12.00	10.00	25.50	25.00	20.50	16.53	10.62	1222
300 x 250	305	254	648	635	520	420	270	550
14 x 10	14.00	10.00	30.00	30.00	23.00	18.30	12.79	1444
350 x 250	356	254	762	762	585	465	325	650
14 x 12	14.00	12.00	30.00	30.00	23.00	18.30	12.79	1555
350 x 250	356	305	762	762	585	465	325	700
16 x 12	16.00	12.00	33.00	33.00	25.60	21.45	16.92	2177
400 x 300	406	305	838	838	650	545	430	980
16 x 14	16.00	14.00	33.00	33.00	25.60	21.45	16.92	2644
400 x 350	406	356	838	838	650	545	430	1190
18 x 16	18.00	16.00	36.00	36.00	28.00	23.62	18.50	3338
450 x 400	457	406	914	914	710	600	470	1500
20 x 16	20.00	16.00	39.00	39.00	30.70	24.40	20.07	3777
500 x 400	508	406	991	991	780	620	510	1700
20 x 18	20.00	18.00	39.00	39.00	30.40	24.40	20.07	4666
500 x 450	508	457	991	991	780	620	510	2100
24 x 20	24.00	20.00	45.00	45.00	36.00	25.10	19.68	(1)
600 x 500	610	508	1143	1143	915	637	500	(1)
30 x 24	30.00	24.00	55.00	55.00	42.90	25.80	21.20	(1)
750 x 600	762	610	1397	1397	1090	655	540	(1)
36 x 30	36.00	30.00	68.00	68.00	50.00	27.60	28.70	(1)
900 x 750	914	762	1727	1727	1270	700	730	(1)

With lever
With gear

*) Other dimension on request.

- Flanges in accordance with ASME B16.5
- Shaded bore sizes (D) according to API 6D

- Butt welding ends according to ASME B16.25
- Shaded end-to-end dimensions according to API 6D

Weight figures are relevant to flanged end valves. (1) Please consult the factory. Note. For dimensions and weights in larger sizes consult the factory. Dimensions B, C, D, E and weights are subject to change without notice.

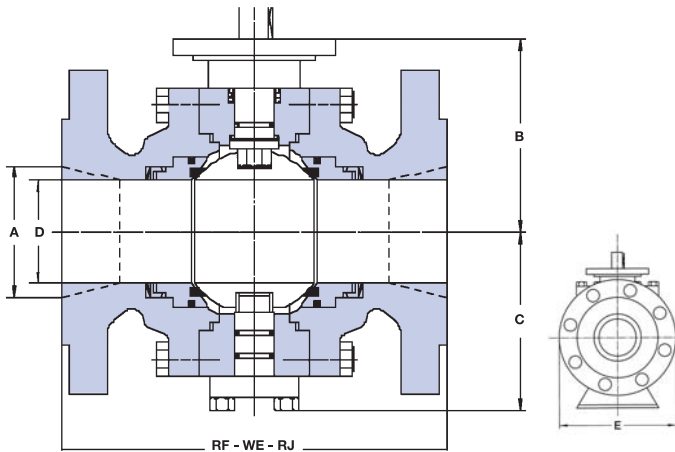

ASME CLASS 600 FULL BORE

SIZE IN/MM	SIDE ENTRY								WEIGHT LBS/KG
	D	RF	RJ	WE	E	B	C		
2	2.00	11.50	11.63	11.50	6.50	7.67	4.33	108	
50	51	292	295	292	165	195	110	49	
3	3.00	14.00	14.13	14.00	8.50	9.44	4.33	166	
80	76	356	359	356	218	240	110	75	
4	4.00	17.00	17.13	17.00	10.70	11.02	6.88	371	
100	102	432	435	432	273	280	175	147	
6	6.00	22.00	22.13	22.00	14.10	12.00	7.67	557	
150	152	559	562	559	360	305	195	253	
8	8.00	26.00	26.13	26.00	16.50	15.74	11.02	1111	
200	203	660	664	660	419	400	280	500	
10	10.00	31.00	31.13	31.00	20.40	17.12	11.22	1733	
250	254	787	791	787	520	435	285	760	
12	12.00	33.00	33.13	33.00	22.60	17.32	12.59	2444	
300	305	838	841	838	575	440	320	1100	
14	14.00	35.00	35.13	35.00	24.70	19.88	13.38	2844	
350	356	889	892	889	628	505	340	1280	
16	16.00	39.00	39.13	39.00	27.60	23.22	16.14	4222	
400	406	991	994	991	700	590	410	1900	
18	18.00	43.00	43.13	43.00	30.50	23.55	17.51	6088	
450	457	1092	1095	1092	775	589	445	2740	
20	20.00	47.00	47.25	47.00	34.10	23.80	20.07	7777	
500	508	1194	1200	1194	865	604	510	3500	
22	22.00	51.00	51.38	51.00	37.40	24.00	20.35	8331	
550	559	1296	1305	1296	950	609	571	3787	
24	24.00	55.00	55.38	55.00	40.50	24.50	25.19	10666	
600	610	1397	1406	1397	1028	622	640	4810	
26	26.00	57.00	57.50	57.00	40.10	24.80	24.30	(1)	
650	660	1448	1460	1448	1020	630	618	(1)	
28	28.00	61.00	61.50	61.00	46.10	26.20	27.20	(1)	
700	711	1549	1562	1549	1172	665	692	(1)	
30	30.00	66.30	66.50	66.30	50.80	29.20	31.50	(1)	
750	762	1684	1697	1684	1290	741	800	(1)	
32	32.00	70.00	70.72	70.00	52.40	29.80	31.70	(1)	
800	813	1778	1794	1778	1330	756	804	(1)	
34	34.00	76.00	76.52	76.00	57.10	30.80	32.20	(1)	
850	864	1930	1946	1930	1450	782	817	(1)	
36	36.00	82.00	82.63	82.00	60.90	34.20	37.20	(1)	
900	914	2083	2098	2083	1546	869	945	(1)	
40	40.00	85.40	85.43	85.40	64.80	36.10	38.60	(1)	
1000	1016	2170	2170	2170	1645	916	980	(1)	
42	42.00	85.60	85.63	85.60	70.80	39.20	43.70	(1)	
1050	1067	2175	2175	2175	1800	995	1110	(1)	
48	48.00	95.90	95.87	95.90	81.50	44.60	49.80	(1)	
1200	1219	2435	2435	2435	2070	1132	1265	(1)	
56	53.54	106.70	106.70	106.70	94.00	51.00	57.50	(1)	
1400	1360	2710	2710	2710	2390	1295	1460	(1)	

With lever
With gear

With lever
With gear

ASME CLASS 600 REDUCED BORE

SIZE IN/MM	SIDE ENTRY								WEIGHT LBS/KG
	A	D	RF	RJ	WE	E	B	C	
2 x 1/2	2.00	1.50	11.50	11.63	11.50	6.50	7.48	3.54	93
50 x 40	51	38	292	295	292	165	190	90	42
3 x 2	3.00	2.00	14.09	14.13	14.00	8.30	14.01	4.33	120
80 x 50	76	51	356	359	356	210	356	110	54
4 x 3	4.00	3.00	17.00	17.13	17.00	14.70	9.44	4.33	211
100 x 80	102	76	432	436	432	373	240	110	95
6 x 4	6.00	4.00	22.00	22.13	22.00	14.00	11.02	6.88	422
150 x 100	152	102	559	562	559	356	280	175	190
8 x 6	8.00	6.00	26.00	26.13	26.00	16.50	12.00	7.67	444
200 x 150	203	152	660	664	660	419	305	195	290
10 x 8	10.00	8.00	31.00	31.13	31.00	20.10	15.74	11.02	1333
250 x 200	254	203	787	791	787	510	400	280	600
12 x 10	12.00	10.00	33.00	33.13	33.00	22.00	17.12	11.22	1866
300 x 250	305	254	838	841	838	560	435	285	840
14 x 10	14.00	10.00	35.00	35.13	35.00	23.80	17.32	12.59	2006
350 x 250	356	254	889	892	889	605	440	320	912
14 x 12	14.00	12.00	35.00	35.13	35.00	23.80	17.32	12.59	2755
350 x 300	356	305	889	892	889	605	440	320	1240
16 x 12	16.00	12.00	39.00	39.13	39.00	27.00	19.88	13.38	2966
400 x 300	406	305	991	994	991	685	505	340	1348
16 x 14	16.00	14.00	35.00	39.13	35.00	24.70	19.88	13.38	3355
400 x 350	406	356	889	994	889	628	505	340	1510
18 x 16	18.00	16.00	43.00	43.13	43.00	29.30	23.22	16.10	3696
450 x 400	457	406	1092	1095	1092	745	590	410	1680
20 x 16	20.00	16.00	47.00	47.25	47.00	32.10	23.80	17.51	4587
500 x 400	508	406	1194	1200	1194	815	604	445	2085
20 x 18	20.00	18.00	47.00	47.25	47.00	32.10	24.00	17.51	5225
500 x 450	508	457	1194	1200	1194	815	609	445	2375
24 x 20	24.00	20.00	55.00	55.38	55.00	37.00	24.50	20.07	9333
600 x 500	610	508	1397	1406	1397	940	622	510	4200
30 x 24	30.00	24.00	66.30	66.50	66.30	44.50	24.80	22.40	(1)
750 x 600	762	610	1684	1697	1684	1130	629	570	(1)
36 x 30	36.00	30.00	82.00	82.63	82.00	51.80	27.90	29.90	(1)
900 x 750	914	762	2083	2098	2083	1315	708	760	(1)

*) Other dimension on request.

- Flanges in accordance with ASME B16.5
- Shaded bore sizes (D) according to API 6D

- Butt welding ends according to ASME B16.25
- Shaded end-to-end dimensions according to API 6D

Weight figures are relevant to flanged end valves. (1) Please consult the factory. Note. For dimensions and weights in larger sizes consult the factory. Dimensions B, C, D, E and weights are subject to change without notice.



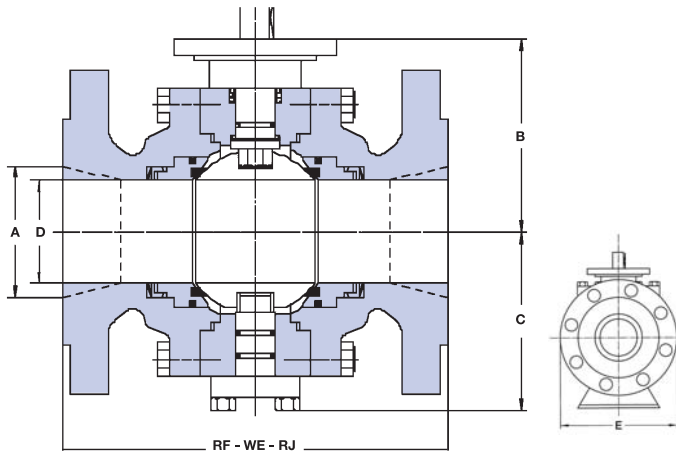

ASME CLASS 900 FULL BORE

SIZE IN/MM	SIDE ENTRY							WEIGHT LBS/KG
	D	RF	RJ	WE	E	B	C	
2	2.00	14.49	14.61	14.49	8.50	7.87	4.72	106
50	51	368	371	368	220	200	120	48
3	3.00	15.00	15.12	15.00	9.49	9.44	5.11	121
80	76	381	384	381	241	240	130	87
4	4.00	17.99	18.11	17.99	11.50	11.02	6.88	319
100	102	457	460	457	290	280	175	145
6	6.00	24.02	24.13	24.02	15.00	13.77	8.66	792
150	152	610	613	610	381	350	220	360
8	8.00	29.02	29.13	29.02	18.50	15.35	10.23	1276
200	203	737	740	737	470	390	260	528
10	10.00	32.99	33.11	32.99	21.46	18.89	14.20	2222
250	254	838	841	838	545	480	310	1730
12	12.00	37.99	38.11	37.99	24.02	17.24	16.14	3322
300	305	965	968	965	610	438	410	1340
14	14.00	40.51	40.87	40.51	25.50	21.45	14.56	3190
350	356	1029	1038	1029	650	545	370	1450
16	16.00	44.49	44.88	44.49	27.95	24.59	16.53	4730
400	406	1130	1140	1130	710	624	420	2540
18	18.00	47.99	48.50	47.99	31.50	24.80	24.29	6204
450	457	1219	1232	1219	800	630	617	2820
20	20.00	52.01	52.48	52.01	35.04	25.00	28.54	9240
500	508	1321	1333	1321	890	635	725	4770
24	24.00	60.98	61.73	60.98	41.69	26.00	32.71	14960
600	610	1549	1568	1549	1059	660	831	7310
28	28.00	69.02	69.88	69.02	48.58	26.54	27.80	(1)
700	711	1753	1775	1753	1234	674	706	(1)
30	30.00	74.02	74.88	74.02	51.18	28.50	30.59	(1)
750	762	1880	1902	1880	1300	725	777	(1)
32	32.00	80.00	80.87	80.00	53.43	30.87	31.90	(1)
800	813	2032	2054	2032	1357	784	810	(1)
34	34.00	85.00	86.14	85.00	57.80	31.77	33.54	(1)
850	864	2159	2188	2159	1468	807	852	(1)
36	36.00	90.00	91.14	90.00	60.31	33.39	35.35	(1)
900	914	2286	2315	2286	1532	848	898	(1)

•) Other dimension on request.

ASME CLASS 900 REDUCED BORE

SIZE IN/MM	SIDE ENTRY							WEIGHT LBS/KG	
	A	D	RF	RJ	WE	E	B		C
2 x 1/2	2.00	1.50	14.49	14.61	14.49	8.60	6.10	4.25	90
50 x 40	51	38	368	371	368	220	155	108	48
3 x 2	3.00	2.00	15.00	15.12	15.00	9.49	7.87	4.72	114
80 x 50	76	51	381	384	381	241	200	120	75
4 x 3	4.00	3.00	17.99	18.11	17.99	11.50	9.44	5.11	209
100 x 80	102	76	457	460	457	290	240	130	106
6 x 4	6.00	4.00	24.02	24.13	24.02	14.90	11.02	6.88	451
150 x 100	152	102	610	613	610	380	280	175	205
8 x 6	8.00	6.00	29.02	29.13	29.02	18.50	13.77	8.66	968
200 x 150	203	152	737	740	737	470	350	220	440
10 x 8	10.00	8.00	32.99	33.11	32.99	21.46	15.35	10.23	1518
250 x 200	254	203	838	841	838	545	390	260	690
12 x 10	12.00	10.00	37.99	38.11	37.99	24.02	18.89	12.20	2541
300 x 250	305	254	965	968	965	610	480	310	1155
14 x 10	14.00	10.00	40.51	40.87	40.51	25.50	17.24	16.14	2728
350 x 250	356	254	1029	1038	1029	650	438	410	1240
14 x 12	14.00	12.00	40.51	40.87	40.51	27.90	17.24	16.14	3597
350 x 300	356	305	1029	1038	1029	710	438	410	1670
16 x 12	16.00	12.00	44.49	44.88	44.49	29.50	21.45	14.56	3800
400 x 300	406	305	1130	1140	1130	750	545	370	1730
16 x 14	16.00	14.00	44.49	44.88	44.49	31.10	21.45	14.56	3740
400 x 350	406	356	1130	1140	1130	790	545	370	1820
18 x 16	18.00	16.00	47.99	48.50	47.99	31.50	24.59	16.53	5368
450 x 400	457	406	1219	1232	1219	800	624	420	2500
20 x 16	20.00	16.00	52.01	52.48	52.01	31.10	25.00	24.29	6320
500 x 400	508	406	1321	1333	1321	790	630	617	2870
20 x 18	20.00	18.00	52.01	52.48	52.01	35.04	25.57	24.29	7150
500 x 450	508	457	1321	1333	1321	890	649	617	3250
24 x 20	24.00	20.00	60.98	61.73	60.98	40.94	25.70	28.54	11880
600 x 500	610	508	1549	1568	1549	1040	652	725	5500
30 x 24	30.00	24.00	74.02	74.88	74.02	48.43	28.00	24.88	(1)
750 x 600	762	610	1880	1902	1880	1230	711	632	(1)
36 x 30	36.00	30.00	90.00	91.14	90.00	57.48	31.70	30.87	(1)
900 x 750	914	762	2286	2315	2286	1460	807	784	(1)

•) Other dimension on request.

- Flanges in accordance with ASME B16.5
- Shaded bore sizes (D) according to API 6D

- Butt welding ends according to ASME B16.25
- Shaded end-to-end dimensions according to API 6D

Weight figures are relevant to flanged end valves. (1) Please consult the factory. Note. For dimensions and weights in larger sizes consult the factory. Dimensions B, C, D, E and weights are subject to change without notice.



FORGED & CAST TOP ENTRY BALL VALVES - BTE

BTE



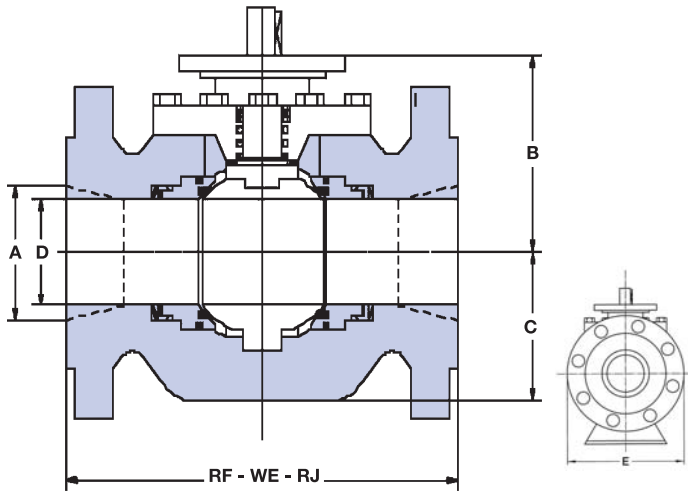

ASME CLASS 150 FULL BORE

SIZE IN/MM	TOP ENTRY						WEIGHT LBS/KG
	D	RF	WE	E	B	C	
2	2.00	7.00	8.50	5.00	5.51	3.54	(1)
50	51	178	216	150	140	90	(1)
3	3.00	8.00	11.13	7.48	7.48	4.13	(1)
80	76	203	283	190	190	105	(1)
4	4.00	9.00	12.00	9.00	11.02	6.53	(1)
100	102	229	305	230	280	166	(1)
6	6.00	15.50	18.00	12.20	11.61	6.88	(1)
150	152	394	457	310	295	175	(1)
8	8.00	18.00	20.50	15.35	12.99	8.26	(1)
200	203	457	521	390	330	210	(1)
10	10.00	21.00	22.00	18.11	15.74	9.84	(1)
250	254	533	559	460	400	250	(1)
12	12.00	24.00	25.00	21.45	18.11	12.20	(1)
300	305	610	635	545	460	310	(1)
14	14.00	27.00	30.00	24.00	18.89	13.38	(1)
350	356	686	762	610	480	340	(1)
16	16.00	30.00	33.00	26.37	21.25	15.15	(1)
400	406	762	838	670	540	385	(1)
18	18.00	34.00	36.00	24.80	23.00	16.85	(1)
450	457	864	914	630	584	428	(1)
20	20.00	36.00	39.00	33.43	24.00	21.45	(1)
500	508	914	991	849	610	545	(1)
22	22.00	40.00	43.00	36.81	24.10	23.00	(1)
550	559	991	1092	935	612	584	(1)
24	24.00	42.00	45.00	39.57	30.70	25.78	(1)
600	610	1067	1143	1005	780	655	(1)
26	26.00	45.00	49.00	41.73	24.69	22.20	(1)
650	660	1143	1245	1060	627	564	(1)
28	28.00	49.00	53.00	44.88	25.35	25.91	(1)
700	711	1244	1347	1140	644	658	(1)
30	30.00	51.00	55.00	47.24	27.20	27.70	(1)
750	762	1295	1397	1200	691	705	(1)
32	32.00	54.00	60.00	51.18	29.21	29.37	(1)
800	813	1371	1524	1300	742	746	(1)
34	34.00	58.00	64.00	53.94	29.88	30.51	(1)
850	864	1473	1626	1370	759	775	(1)
36	36.00	60.00	68.00	56.30	31.97	31.77	(1)
900	914	1524	1728	1430	812	807	(1)
40	40.00	69.00	77.00	63.00	35.43	35.35	(1)
1000	1016	1753	1956	1600	900	898	(1)
42	42.00	72.00	82.00	64.96	37.13	37.00	(1)
1050	1067	1855	2083	1656	943	940	(1)
48	48.00	80.00	94.00	75.59	43.19	41.73	(1)
1200	1219	2134	2388	1920	1097	1060	(1)

*) Other dimension on request.

ASME CLASS 150 REDUCED BORE

SIZE IN/MM	TOP ENTRY						WEIGHT LBS/KG	
	A	D	RF	WE	E	B		C
2 x 1/2	2.00	1.50	7.00	8.50	5.90	4.00	3.00	(1)
50 x 40	51	38	178	216	150	101	76	(1)
3 x 2	3.00	2.00	11.13	3.03	7.48	5.51	3.54	(1)
80 x 50	76	51	203	283	190	140	90	(1)
4 x 3	4.00	3.00	12.00	4.02	9.00	7.48	4.13	(1)
100 x 80	102	76	229	305	230	190	105	(1)
6 x 4	6.00	4.00	15.50	18.00	12.20	11.02	6.53	(1)
150 x 100	152	102	394	457	310	280	166	(1)
8 x 6	8.00	6.00	18.00	20.50	15.35	11.61	6.88	(1)
200 x 150	203	152	457	521	395	295	175	(1)
10 x 8	10.00	8.00	21.00	22.00	15.98	12.99	8.26	(1)
250 x 200	254	203	533	559	406	330	210	(1)
12 x 10	12.00	10.00	24.00	25.00	19.02	15.74	9.84	(1)
300 x 250	305	254	610	635	483	400	250	(1)
14 x 10	14.00	10.00	27.00	30.00	21.06	18.11	12.30	(1)
350 x 250	356	254	686	762	535	460	310	(1)
14 x 12	14.00	12.00	27.00	30.00	21.06	18.11	12.20	(1)
350 x 250	356	305	686	762	535	460	310	(1)
16 x 12	16.00	12.00	30.00	33.00	23.43	18.89	13.38	(1)
400 x 300	406	305	762	838	595	480	340	(1)
16 x 14	16.00	14.00	30.00	33.00	23.43	18.89	13.38	(1)
400 x 350	406	356	762	838	595	480	340	(1)
18 x 16	18.00	16.00	34.00	36.00	24.80	21.25	15.15	(1)
450 x 400	457	406	864	914	630	540	385	(1)
20 x 16	20.00	16.00	36.00	39.00	27.56	22.83	16.85	(1)
500 x 400	508	406	914	991	700	580	428	(1)
20 x 18	20.00	18.00	36.00	39.00	27.56	22.84	16.85	(1)
500 x 450	508	457	914	991	700	580	428	(1)
24 x 20	24.00	20.00	42.00	45.00	32.28	23.00	18.00	(1)
600 x 500	610	508	1067	1143	820	584	457	(1)
30 x 24	30.00	24.00	51.00	55.00	38.78	25.15	19.49	(1)
750 x 600	762	610	1295	1397	985	638	495	(1)
36 x 30	36.00	30.00	60.00	68.00	46.06	27.17	27.56	(1)
900 x 750	914	762	1524	1728	1170	690	700	(1)

*) Other dimension on request.

- Flanges in accordance with ASME B16.5
- Shaded bore sizes (D) according to API 6D

- Butt welding ends according to ASME B16.25
- Shaded end-to-end dimensions according to API 6D

Weight figures are relevant to flanged end valves. (1) Please consult the factory. Note. For dimensions and weights in larger sizes consult the factory. Dimensions B, C, D, E and weights are subject to change without notice.



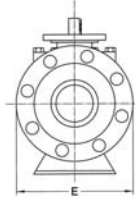
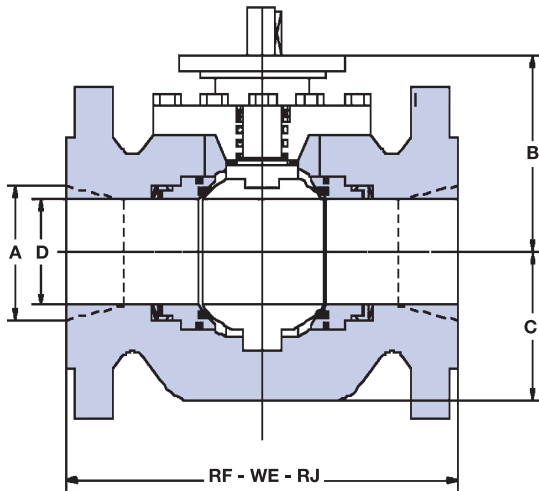

ASME CLASS 300 FULL BORE

SIZE IN/MM	TOP ENTRY						WEIGHT LB/KG
	D	RF	WE	E	B	C	
2	2.00	8.50	8.50	6.50	7.87	4.72	(1)
50	51	216	216	165	200	120	(1)
3	3.00	11.10	11.10	8.50	9.44	5.11	(1)
80	76	283	283	218	240	130	(1)
4	4.00	12.00	12.00	10.00	11.02	5.90	(1)
100	102	305	305	254	280	150	(1)
6	6.00	15.90	18.00	12.20	11.61	6.88	(1)
150	152	403	457	310	295	175	(1)
8	8.00	19.80	20.50	15.40	12.99	8.26	(1)
200	203	502	521	390	330	210	(1)
10	10.00	22.40	22.00	18.50	16.53	10.62	(1)
250	254	568	559	470	420	270	(1)
12	12.00	25.50	25.00	21.30	18.30	12.79	(1)
300	305	648	635	545	465	325	(1)
14	14.00	30.00	30.00	24.80	21.45	16.92	(1)
350	356	762	762	630	545	430	(1)
16	16.00	33.00	33.00	27.20	23.62	18.50	(1)
400	406	838	838	690	600	470	(1)
18	18.00	36.00	36.00	30.30	23.10	20.07	(1)
450	457	914	914	770	586	510	(1)
20	20.00	39.00	39.00	33.50	23.90	19.68	(1)
500	508	991	991	850	607	500	(1)
22	22.00	43.00	43.00	37.00	24.01	21.00	(1)
550	559	1092	1092	940	612	533	(1)
24	24.00	45.00	45.00	39.70	24.50	23.62	(1)
600	610	1143	1143	1010	622	600	(1)
26	26.00	49.00	49.00	42.50	24.80	22.80	(1)
650	660	1245	1245	1080	630	580	(1)
28	28.00	53.00	53.00	45.30	25.20	26.60	(1)
700	711	1346	1346	1150	640	675	(1)
30	30.00	55.00	55.00	48.40	27.60	28.70	(1)
750	762	1397	1397	1230	700	730	(1)
32	32.00	60.00	60.00	52.00	29.30	29.90	(1)
800	813	1524	1524	1320	745	760	(1)
34	34.00	64.00	64.00	54.50	29.90	31.50	(1)
850	864	1626	1626	1380	760	800	(1)
36	36.00	68.00	68.00	56.9	31.70	32.5	(1)
900	914	1727	1727	1445	805	825	(1)
40	40.00	77.00	77.00	64.10	35.40	36.2	(1)
1000	1016	1956	1956	1630	900	920	(1)
42	42.00	82.00	82.00	66.90	38.10	38.40	(1)
1050	1067	2083	2083	1700	968	980	(1)
48	48.00	85.40	85.40	74.80	43.30	45.60	(1)
1200	1219	2170	2170	1960	1100	1160	(1)

*) Other dimension on request.

ASME CLASS 300 REDUCED BORE

SIZE IN/MM	TOP ENTRY							WEIGHT LB/KG
	A	D	RF	WE	E	B	C	
2 x 1/2	2.00	1.50	8.50	8.50	6.50	8.22	2.75	(1)
50 x 40	51	38	216	216	165	209	70	(1)
3 x 2	3.00	2.00	11.10	11.10	8.50	7.87	4.72	(1)
80 x 50	76	51	283	283	218	200	120	(1)
4 x 3	4.00	3.00	12.00	12.00	10.00	9.44	5.11	(1)
100 x 80	102	76	305	305	254	240	130	(1)
6 x 4	6.00	4.00	15.90	18.00	12.20	11.02	5.90	(1)
150 x 100	152	102	403	457	310	280	150	(1)
8 x 6	8.00	6.00	19.80	20.50	15.40	11.61	6.88	(1)
200 x 150	203	152	502	521	390	295	175	(1)
10 x 8	10.00	8.00	22.40	22.00	17.50	12.99	8.26	(1)
250 x 200	254	203	568	559	445	330	210	(1)
12 x 10	12.00	10.00	25.50	25.00	20.50	16.53	10.62	(1)
300 x 250	305	254	648	635	520	420	270	(1)
14 x 10	14.00	10.00	30.00	30.00	23.00	-	-	(1)
350 x 250	356	254	762	762	585	-	-	(1)
14 x 12	14.00	12.00	30.00	30.00	23.00	18.30	12.79	(1)
350 x 250	356	305	762	762	585	465	325	(1)
16 x 12	16.00	12.00	33.00	33.00	25.60	-	-	(1)
400 x 300	406	305	838	838	650	-	-	(1)
16 x 14	16.00	14.00	33.00	33.00	25.60	21.45	16.92	(1)
400 x 350	406	356	838	838	650	545	430	(1)
18 x 16	18.00	16.00	36.00	36.00	28.00	23.62	18.50	(1)
450 x 400	457	406	914	914	710	600	470	(1)
20 x 16	20.00	16.00	39.00	39.00	30.70	-	-	(1)
500 x 400	508	406	991	991	780	-	-	(1)
20 x 18	20.00	18.00	39.00	39.00	30.40	24.40	20.07	(1)
500 x 450	508	457	991	991	780	620	510	(1)
24 x 20	24.00	20.00	45.00	45.00	36.00	28.89	19.68	(1)
600 x 500	610	508	1143	1143	915	734	500	(1)
30 x 24	30.00	24.00	55.00	55.00	42.90	-	-	(1)
750 x 600	762	610	1397	1397	1090	-	-	(1)
36 x 30	36.00	30.00	68.00	68.00	50.00	-	-	(1)
900 x 750	914	762	1727	1727	1270	-	-	(1)

*) Other dimension on request.

- Flanges in accordance with ASME B16.5
- Shaded bore sizes (D) according to API 6D

- Butt welding ends according to ASME B16.25
- Shaded end-to-end dimensions according to API 6D

Weight figures are relevant to flanged end valves. (1) Please consult the factory. Note. For dimensions and weights in larger sizes consult the factory. Dimensions B, C, D, E and weights are subject to change without notice.

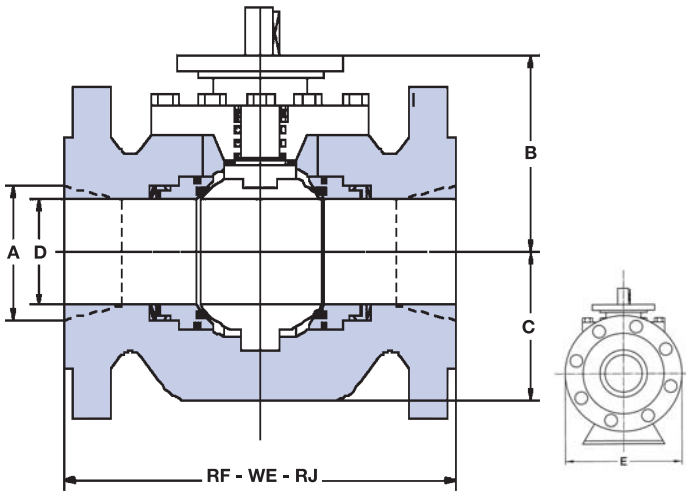

ASME CLASS 600 FULL BORE

SIZE IN/MM	TOP ENTRY							WEIGHT LB/KG
	D	RF	RJ	WE	E	B	C	
2	2.00	11.50	11.63	11.50	6.50	7.67	4.33	(1)
50	51	292	295	292	165	195	110	(1)
3	3.00	14.00	14.13	14.00	8.50	9.44	4.33	(1)
80	76	356	359	356	218	240	110	(1)
4	4.00	17.00	17.13	17.00	10.70	11.02	6.88	(1)
100	102	432	435	432	273	280	175	(1)
6	6.00	22.00	22.13	22.00	14.10	12.00	7.67	(1)
150	152	559	562	559	360	305	195	(1)
8	8.00	26.00	26.13	26.00	16.50	15.74	11.02	(1)
200	203	660	664	660	419	400	280	(1)
10	10.00	31.00	31.13	31.00	20.40	17.12	11.22	(1)
250	254	787	791	787	520	435	285	(1)
12	12.00	33.00	33.13	33.00	22.60	17.32	12.59	(1)
300	305	838	841	838	575	440	320	(1)
14	14.00	35.00	35.13	35.00	24.70	19.88	13.38	(1)
350	356	889	892	889	628	505	340	(1)
16	16.00	39.00	39.13	39.00	27.60	23.22	16.14	(1)
400	406	991	994	991	700	590	410	(1)
18	18.00	43.00	43.13	43.00	30.50	23.55	17.51	(1)
450	457	1092	1095	1092	775	589	445	(1)
20	20.00	47.00	47.25	47.00	34.10	23.80	20.07	(1)
500	508	1194	1200	1194	865	604	510	(1)
22	22.00	51.00	51.38	51.00	37.40	24.00	20.35	(1)
550	559	1296	1305	1296	950	609	571	(1)
24	24.00	55.00	55.38	55.00	40.50	24.50	25.19	(1)
600	610	1397	1406	1397	1028	622	640	(1)
26	26.00	57.00	57.50	57.00	40.10	24.80	24.30	(1)
650	660	1448	1460	1448	1020	630	618	(1)
28	28.00	61.00	61.50	61.00	46.10	26.20	27.20	(1)
700	711	1549	1562	1549	1172	665	692	(1)
30	30.00	66.30	65.50	66.30	50.80	29.20	31.50	(1)
750	762	1684	1697	1684	1290	741	800	(1)
32	32.00	70.00	70.72	70.00	52.40	29.80	31.70	(1)
800	813	1778	1794	1778	1330	756	804	(1)
34	34.00	76.00	76.52	76.00	57.10	30.80	32.20	(1)
850	864	1930	1946	1930	1450	782	817	(1)
36	36.00	82.00	82.63	82.00	60.90	34.20	37.20	(1)
900	914	2083	2098	2083	1546	869	945	(1)
40	40.00	85.40	85.43	85.40	64.80	36.10	38.60	(1)
1000	1016	2170	2170	2170	1645	916	980	(1)
42	42.00	85.60	85.63	85.60	70.80	39.20	43.70	(1)
1050	1067	2175	2175	2175	1800	995	1110	(1)
48	48.00	95.90	95.87	95.90	81.50	44.60	49.80	(1)
1200	1219	2435	2435	2435	2070	1132	1265	(1)

• Other dimension on request.

ASME CLASS 600 REDUCED BORE

SIZE IN/MM	TOP ENTRY							WEIGHT LB/KG	
	A	D	RF	RJ	WE	B	C		
2 x 1/2	2.00	1.50	11.50	11.63	11.50	6.50	8.22	2.75	(1)
50 x 40	51	38	292	295	292	165	209	70	(1)
3 x 2	3.00	2.00	14.09	14.13	14.00	8.30	7.67	4.33	(1)
80 x 50	76	51	356	359	356	210	195	110	(1)
4 x 3	4.00	3.00	17.00	17.13	17.00	14.70	9.44	4.33	(1)
100 x 80	102	76	432	436	432	373	240	110	(1)
6 x 4	6.00	4.00	22.00	22.13	22.00	14.00	11.02	6.88	(1)
150 x 100	152	102	559	562	559	356	280	175	(1)
8 x 6	8.00	6.00	26.00	26.13	26.00	16.50	12.00	7.67	(1)
200 x 150	203	152	660	664	660	419	305	195	(1)
10 x 8	10.00	8.00	31.00	31.13	31.00	20.10	15.74	11.02	(1)
250 x 200	254	203	787	791	787	510	400	280	(1)
12 x 10	12.00	10.00	33.00	33.13	33.00	22.00	17.12	11.22	(1)
300 x 250	305	254	838	841	838	560	435	285	(1)
14 x 10	14.00	10.00	35.00	35.13	35.00	23.80	-	-	(1)
350 x 250	356	254	889	892	889	605	-	-	(1)
14 x 12	14.00	12.00	35.00	35.13	35.00	23.80	17.32	12.59	(1)
350 x 250	356	305	889	892	889	605	440	320	(1)
16 x 12	16.00	12.00	39.00	39.13	39.00	27.00	-	-	(1)
400 x 300	406	305	991	994	991	685	-	-	(1)
16 x 14	16.00	14.00	35.00	35.13	35.00	24.70	19.88	13.38	(1)
400 x 350	406	356	889	894	889	628	505	340	(1)
18 x 16	18.00	16.00	43.00	43.13	43.00	29.30	23.22	16.14	(1)
450 x 400	457	406	1092	1095	1092	745	590	410	(1)
20 x 16	20.00	16.00	47.00	47.25	47.00	32.10	-	-	(1)
500 x 400	508	406	1194	1200	1194	815	-	-	(1)
20 x 18	20.00	18.00	47.00	47.25	47.00	32.10	27.55	17.51	(1)
500 x 450	508	457	1194	1200	1194	815	700	445	(1)
24 x 20	24.00	20.00	55.00	55.38	55.00	37.00	30.51	20.07	(1)
600 x 500	610	508	1397	1406	1397	940	775	510	(1)
30 x 24	30.00	24.00	66.30	65.50	66.30	44.50	-	-	(1)
750 x 600	762	610	1684	1697	1684	1130	-	-	(1)
36 x 30	36.00	30.00	82.00	82.63	82.00	51.80	-	-	(1)
900 x 750	914	762	2083	2098	2083	1315	-	-	(1)

• Other dimension on request.

- Flanges in accordance with ASME B16.5
- Shaded bore sizes (D) according to API 6D

- Butt welding ends according to ASME B16.25
- Shaded end-to-end dimensions according to API 6D

Weight figures are relevant to flanged end valves. (1) Please consult the factory. Note. For dimensions and weights in larger sizes consult the factory. Dimensions B, C, D, E and weights are subject to change without notice.



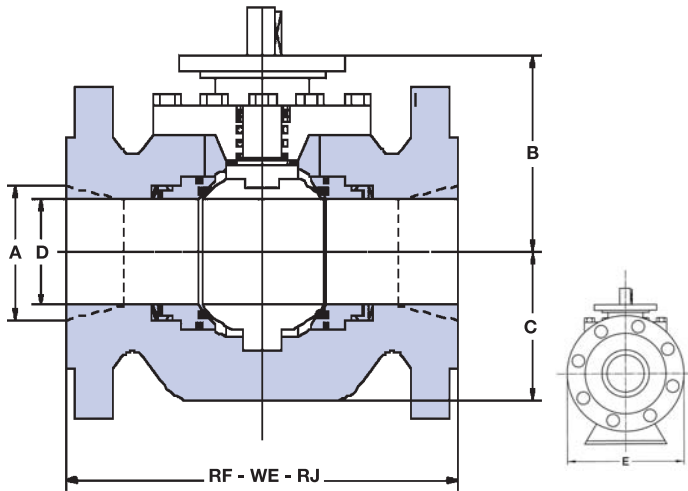

ASME CLASS 900 FULL BORE

SIZE IN/MM	TOP ENTRY							WEIGHT LBS/KG
	D	RF	RJ	WE	E	B	C	
2	2.00	14.49	14.61	14.49	8.50	7.87	4.72	(1)
50	51	368	371	368	220	200	120	(1)
3	3.00	15.00	15.12	15.00	9.49	9.44	5.11	(1)
80	76	381	384	381	241	240	130	(1)
4	4.00	17.99	18.11	17.99	11.50	11.02	6.88	(1)
100	102	457	460	457	290	280	175	(1)
6	6.00	24.02	24.13	24.02	15.00	13.77	8.66	(1)
150	152	610	613	610	381	350	220	(1)
8	8.00	29.02	29.13	29.02	18.50	15.35	10.23	(1)
200	203	737	740	737	470	390	260	(1)
10	10.00	32.99	33.11	32.99	21.46	18.89	14.20	(1)
250	254	838	841	838	545	480	310	(1)
12	12.00	37.99	38.11	37.99	24.02	17.24	16.14	(1)
300	305	965	968	965	610	438	410	(1)
14	14.00	40.51	40.87	40.51	25.50	21.45	14.56	(1)
350	356	1029	1038	1029	650	545	370	(1)
16	16.00	44.49	44.88	44.49	27.95	25.59	16.53	(1)
400	406	1130	1140	1130	710	650	420	(1)
18	18.00	47.99	48.50	47.99	31.50	26.57	24.29	(1)
450	457	1219	1232	1219	800	675	617	(1)
20	20.00	52.01	52.48	52.01	35.04	31.10	28.54	(1)
500	508	1321	1333	1321	890	790	725	(1)
24	24.00	60.98	61.73	60.98	41.69	36.02	32.71	(1)
650	610	1549	1568	1549	1059	915	831	(1)
28	28.00	69.02	69.88	69.02	48.58	-	-	(1)
700	711	1753	1775	1753	1234	-	-	(1)
30	30.00	74.02	74.88	74.02	51.18	-	-	(1)
750	762	1880	1902	1880	1300	-	-	(1)
32	32.00	80.00	80.87	80.00	53.43	-	-	(1)
800	813	2032	2054	2032	1357	-	-	(1)
34	34.00	85.00	86.14	85.00	57.80	-	-	(1)
850	864	2159	2188	2159	1468	-	-	(1)
36	36.00	90.00	91.14	90.00	60.31	-	-	(1)
900	914	2286	2315	2286	1532	-	-	(1)

With lever
With gear

With lever
With gear

•) Other dimension on request.

ASME CLASS 900 REDUCED BORE

SIZE IN/MM	TOP ENTRY							WEIGHT LBS/KG	
	A	D	RF	RJ	WE	E	B		C
2 x 1/2	2.00	1.50	14.49	14.61	14.49	8.60	8.46	3.14	(1)
50 x 40	51	38	368	371	368	220	215	80	(1)
3 x 2	3.00	2.00	15.00	15.12	15.00	9.49	7.87	4.72	(1)
80 x 50	76	51	381	384	381	241	200	120	(1)
4 x 3	4.00	3.00	17.99	18.11	17.99	11.50	9.44	5.11	(1)
100 x 80	102	76	457	460	457	290	240	130	(1)
6 x 4	6.00	4.00	24.02	24.13	24.02	14.90	11.02	6.88	(1)
150 x 100	152	102	610	613	610	380	280	175	(1)
8 x 6	8.00	6.00	29.02	29.13	29.02	18.50	13.77	8.66	(1)
200 x 150	203	152	737	740	737	470	350	220	(1)
10 x 8	10.00	8.00	32.99	33.11	32.99	21.46	15.35	10.23	(1)
250 x 200	254	203	838	841	838	545	390	260	(1)
12 x 10	12.00	10.00	37.99	38.11	37.99	24.02	18.89	14.20	(1)
300 x 250	305	254	965	968	965	610	480	310	(1)
14 x 10	14.00	10.00	40.51	40.87	40.51	25.50	-	-	(1)
350 x 250	356	254	1029	1038	1029	650	-	-	(1)
14 x 12	14.00	12.00	40.51	40.87	40.51	27.90	17.24	16.14	(1)
350 x 250	356	305	1029	1038	1029	710	438	410	(1)
16 x 12	16.00	12.00	44.49	44.88	44.49	29.50	-	-	(1)
400 x 300	406	305	1130	1140	1130	750	-	-	(1)
16 x 14	16.00	14.00	44.49	44.88	44.49	31.10	21.45	14.56	(1)
400 x 350	406	356	1130	1140	1130	790	545	370	(1)
18 x 16	18.00	16.00	47.99	48.50	47.99	31.50	25.59	16.53	(1)
450 x 400	457	406	1219	1232	1219	800	650	420	(1)
20 x 16	20.00	16.00	52.01	52.48	52.01	31.10	-	-	(1)
500 x 400	508	406	1321	1333	1321	790	-	-	(1)
20 x 18	20.00	18.00	52.01	52.48	52.01	35.04	26.57	24.29	(1)
500 x 450	508	457	1321	1333	1321	890	675	617	(1)
24 x 20	24.00	20.00	60.98	61.73	60.98	40.94	31.10	28.54	(1)
600 x 500	610	508	1549	1568	1549	1040	790	725	(1)
30 x 24	30.00	24.00	74.02	74.88	74.02	48.43	-	-	(1)
750 x 600	762	610	1880	1902	1880	1230	-	-	(1)
36 x 30	36.00	30.00	90.00	91.14	90.00	57.48	-	-	(1)
900 x 750	914	762	2286	2315	2286	1460	-	-	(1)

•) Other dimension on request.

REDUCED BORE CLASS 150-2500

DIA NOM.	TOP ENTRY							CODE	
	1/2	3/4	1	1 1/2					
CLASS 150	9	165	12	191	17	216	29	241	BTE-1
CLASS 300	9	165	12	191	17	216	29	241	BTE-3
CLASS 600	9	165	12	191	17	216	29	241	BTE-6
CLASS 1500	9	216	11	229	14	254	26	305	BTE-9
CLASS 2500	9	263	11	273	14	308	24	384	BTE-25
DIMENSION	BORE	END to END	BORE	END to END	BORE	END to END	BORE	END to END	-



- Flanges in accordance with ASME B16.5
- Shaded bore sizes (D) according to API 6D
- Butt welding ends according to ASME B16.25
- Shaded end-to-end dimensions according to API 6D

Weight figures are relevant to flanged end valves. (1) Please consult the factory. Note. For dimensions and weights in larger sizes consult the factory. Dimensions B, C, D, E and weights are subject to change without notice.

WSE

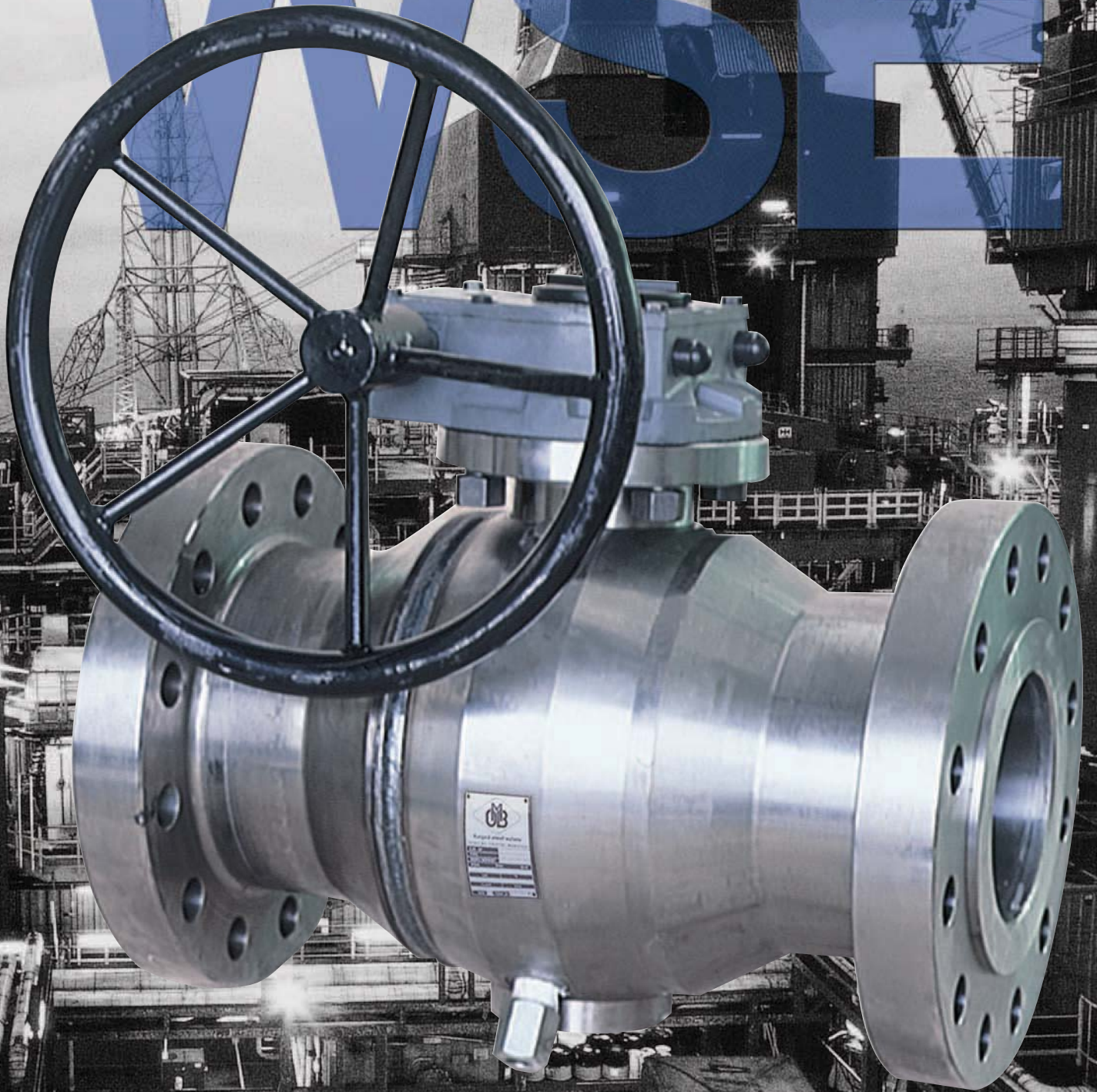

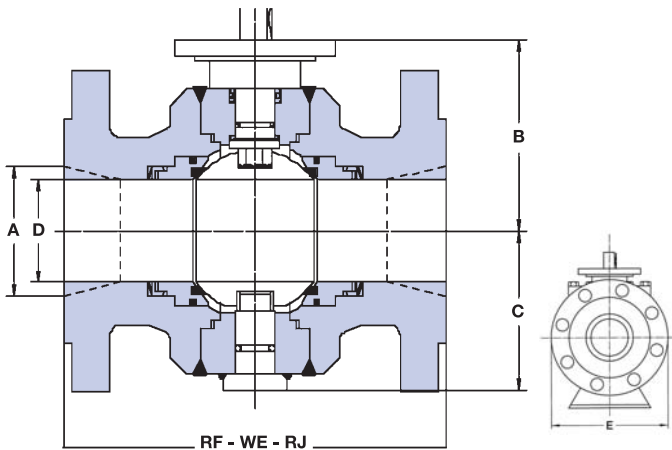

ASME CLASS 150 FULL BORE

SIZE IN/MM	WELDED BODY						WEIGHT LB/KG
	D	RF	WE	E	B	C	
2	2.00	7.00	8.50	5.00	5.51	3.54	(1)
50	51	178	216	150	140	90	(1)
3	3.00	8.00	11.13	7.48	7.48	4.13	(1)
80	76	203	283	190	190	105	(1)
4	4.00	9.00	12.00	9.00	11.02	6.53	(1)
100	102	229	305	230	280	166	(1)
6	6.00	15.50	18.00	12.20	11.61	6.88	(1)
150	152	394	457	310	295	175	(1)
8	8.00	18.00	20.50	15.35	12.99	8.26	(1)
200	203	457	521	390	330	210	(1)
10	10.00	21.00	22.00	18.11	15.74	9.84	(1)
250	254	533	559	460	400	250	(1)
12	12.00	24.00	25.00	21.45	18.11	12.20	(1)
300	305	610	635	545	460	310	(1)
14	14.00	27.00	30.00	24.00	18.89	13.38	(1)
350	356	686	762	610	480	340	(1)
16	16.00	30.00	33.00	26.37	21.25	15.15	(1)
400	406	762	838	670	540	385	(1)
18	18.00	34.00	36.00	24.80	22.83	16.85	(1)
450	457	864	914	630	580	428	(1)
20	20.00	36.00	39.00	33.43	28.14	21.45	(1)
500	508	914	991	849	715	545	(1)
22	22.00	40.00	43.00	36.81	24.00	23.00	(1)
550	559	991	1092	935	610	584	(1)
24	24.00	42.00	45.00	39.57	30.70	25.78	(1)
600	610	1067	1143	1005	780	655	(1)
26	26.00	45.00	49.00	41.73	24.69	22.20	(1)
650	660	1143	1245	1060	627	564	(1)
28	28.00	49.00	53.00	44.88	25.35	25.91	(1)
700	711	1244	1347	1140	644	658	(1)
30	30.00	51.00	55.00	47.24	27.20	27.70	(1)
750	762	1295	1397	1200	691	705	(1)
32	32.00	54.00	60.00	51.18	29.21	29.37	(1)
800	813	1371	1524	1300	742	746	(1)
34	34.00	58.00	64.00	53.94	29.88	30.51	(1)
850	864	1473	1626	1370	759	775	(1)
36	36.00	60.00	68.00	56.30	31.97	31.77	(1)
900	914	1524	1728	1430	812	807	(1)
40	40.00	69.00	77.00	63.00	35.43	35.35	(1)
1000	1016	1753	1956	1600	900	898	(1)
42	42.00	72.00	82.00	64.96	37.13	37.00	(1)
1050	1067	1855	2083	1656	943	940	(1)
48	48.00	80.00	94.00	75.59	43.19	41.73	(1)
1200	1219	2134	2388	1920	1097	1060	(1)
56	53.54	98.00	98.00	89.00	52.00	50.00	(1)
1400	1360	2490	2490	2260	1321	1270	(1)

With lever
With gear

ASME CLASS 150 REDUCED BORE

SIZE IN/MM	SIDE ENTRY							WEIGHT LB/KG
	A	D	RF	WE	E	B	C	
2 x 1/2	2.00	1.50	7.00	8.50	5.90	4.00	3.00	33
50 x 40	51	38	178	216	150	101	76	15
3 x 2	3.00	2.00	11.13	3.03	7.48	5.51	3.54	66
80 x 50	76	51	203	283	190	140	90	30
4 x 3	4.00	3.00	12.00	4.02	9.00	7.48	4.13	133
100 x 80	102	76	229	305	230	190	105	60
6 x 4	6.00	4.00	15.50	18.00	12.20	11.02	6.53	262
150 x 100	152	102	394	457	310	280	166	118
8 x 6	8.00	6.00	18.00	20.50	15.35	11.61	6.88	366
200 x 150	203	152	457	521	395	295	175	165
10 x 8	10.00	8.00	21.00	22.00	15.98	12.99	8.26	588
250 x 200	254	203	533	559	406	330	210	265
12 x 10	12.00	10.00	24.00	25.00	19.02	15.74	9.84	1000
300 x 250	305	254	610	635	483	400	250	450
14 x 10	14.00	10.00	27.00	30.00	21.06	18.11	12.20	1155
350 x 250	356	254	686	762	535	460	310	520
14 x 12	14.00	12.00	27.00	30.00	21.06	18.11	12.20	1577
350 x 300	356	305	686	762	535	460	310	710
16 x 12	16.00	12.00	30.00	33.00	23.43	18.89	13.38	1755
400 x 300	406	305	762	838	595	480	340	790
16 x 14	16.00	14.00	30.00	33.00	23.43	18.89	13.38	2000
400 x 350	406	356	762	838	595	480	340	900
18 x 16	18.00	16.00	34.00	36.00	24.80	21.25	15.15	2777
450 x 400	457	406	864	914	630	540	385	1250
20 x 16	20.00	16.00	36.00	39.00	27.56	22.83	16.85	1555
500 x 400	508	406	914	991	700	580	428	1150
20 x 18	20.00	18.00	36.00	39.00	27.56	22.83	16.85	2777
500 x 450	508	457	914	991	700	580	428	1250
24 x 20	24.00	20.00	42.00	45.00	32.28	23.00	18.00	6400
600 x 500	610	508	1067	1143	820	584	457	2990
30 x 24	30.00	24.00	51.00	55.00	38.78	25.15	20.28	(1)
750 x 600	762	610	1295	1397	985	638	515	(1)
36 x 30	36.00	30.00	60.00	68.00	46.06	27.17	27.56	(1)
900 x 750	914	762	1524	1728	1170	690	700	(1)

*) Other dimension on request.

- Flanges in accordance with ASME B16.5
- Shaded bore sizes (D) according to API 6D

- Butt welding ends according to ASME B16.25
- Shaded end-to-end dimensions according to API 6D

Weight figures are relevant to flanged end valves. (1) Please consult the factory. Note. For dimensions and weights in larger sizes consult the factory. Dimensions B, C, D, E and weights are subject to change without notice.



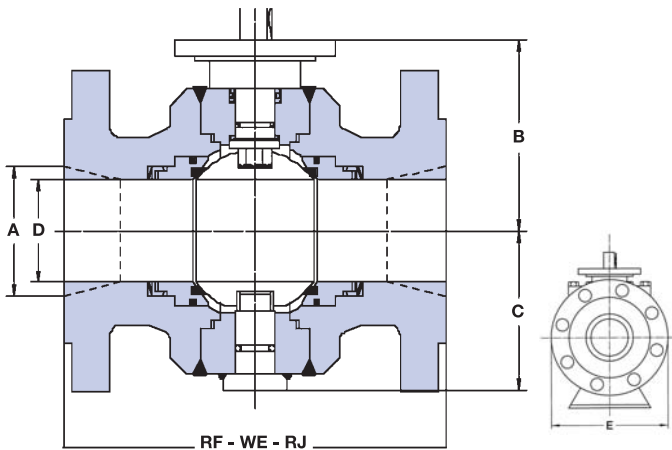

ASME CLASS 300 FULL BORE

SIZE IN/MM	WELDED BODY						WEIGHT LBS/KG
	D	RF	WE	E	B	C	
2	2.00	8.50	8.50	6.50	7.87	4.72	(1)
50	51	216	216	165	200	120	(1)
3	3.00	11.10	11.10	8.50	9.44	5.11	(1)
80	76	283	283	218	240	130	(1)
4	4.00	12.00	12.00	10.00	11.02	5.90	(1)
100	102	305	305	254	280	150	(1)
6	6.00	15.90	18.00	12.20	11.61	6.88	(1)
150	152	403	457	310	295	175	(1)
8	8.00	19.80	20.50	15.40	12.99	8.26	(1)
200	203	502	521	390	330	210	(1)
10	10.00	22.40	22.00	18.50	16.53	10.62	(1)
250	254	568	559	470	420	270	(1)
12	12.00	25.50	25.00	21.30	18.30	12.79	(1)
300	305	648	635	545	465	325	(1)
14	14.00	30.00	30.00	24.80	21.45	16.92	(1)
350	356	762	762	630	545	430	(1)
16	16.00	33.00	33.00	27.20	23.62	18.50	(1)
400	406	838	838	690	600	470	(1)
18	18.00	36.00	36.00	30.30	23.10	20.07	(1)
450	457	914	914	770	586	510	(1)
20	20.00	39.00	39.00	33.50	23.90	19.68	(1)
500	508	991	991	850	607	500	(1)
22	22.00	43.00	43.00	37.00	24.10	-	(1)
550	559	1092	1092	940	612	-	(1)
24	24.00	45.00	45.00	39.70	24.50	23.62	(1)
600	610	1143	1143	1010	622	600	(1)
26	26.00	49.00	49.00	42.50	24.80	22.80	(1)
650	660	1245	1245	1080	630	580	(1)
28	28.00	53.00	53.00	45.30	25.20	26.60	(1)
700	711	1346	1346	1150	640	675	(1)
30	30.00	55.00	55.00	48.40	27.60	28.70	(1)
750	762	1397	1397	1230	700	730	(1)
32	32.00	60.00	60.00	52.00	29.30	29.90	(1)
800	813	1524	1524	1320	745	760	(1)
34	34.00	64.00	64.00	54.50	29.90	31.50	(1)
850	864	1626	1626	1380	760	800	(1)
36	36.00	68.00	68.00	56.9	31.70	32.50	(1)
900	914	1727	1727	1445	805	825	(1)
40	40.00	77.00	77.00	64.10	35.40	36.20	(1)
1000	1016	1956	1956	1630	900	920	(1)
42	42.00	82.00	82.00	66.90	38.10	38.40	(1)
1050	1067	2083	2083	1700	968	980	(1)
48	48.00	85.40	85.40	74.80	43.30	45.60	(1)
1200	1219	2170	2170	1960	1100	1160	(1)
56	53.54	108.00	108.00	89.00	50.00	50.00	(1)
1400	1360	2743	2743	2260	1270	1270	(1)

With lever
With gear

ASME CLASS 300 REDUCED BORE

SIZE IN/MM	WELDED BODY						WEIGHT LBS/KG	
	A	D	RF	WE	E	C		
2 x 1/2	2.00	1.50	8.50	8.50	6.50	6.88	3.14	44
50 x 40	51	38	216	216	165	175	80	20
3 x 2	3.00	2.00	11.10	11.10	8.50	7.87	4.72	122
80 x 50	76	51	283	283	218	200	120	55
4 x 3	4.00	3.00	12.00	12.00	10.00	9.44	5.11	153
100 x 80	102	76	305	305	254	240	130	69
6 x 4	6.00	4.00	15.90	18.00	12.20	11.02	5.90	260
150 x 100	152	102	403	457	310	280	150	117
8 x 6	8.00	6.00	19.80	20.50	15.40	11.61	6.88	433
200 x 150	203	152	502	521	390	295	175	195
10 x 8	10.00	8.00	22.40	22.00	17.50	12.99	8.26	722
250 x 200	254	203	568	559	445	330	210	325
12 x 10	12.00	10.00	25.50	25.00	20.50	16.53	10.62	1222
300 x 250	305	254	648	635	520	420	270	550
14 x 10	14.00	10.00	30.00	30.00	23.00	18.30	12.79	1444
350 x 250	356	254	762	762	585	465	325	650
14 x 12	14.00	12.00	30.00	30.00	23.00	18.30	12.79	1555
350 x 250	356	305	762	762	585	465	325	700
16 x 12	16.00	12.00	33.00	33.00	25.60	21.45	16.92	2177
400 x 300	406	305	838	838	650	545	430	980
16 x 14	16.00	14.00	33.00	33.00	25.60	21.45	16.92	2644
400 x 350	406	356	838	838	650	545	430	1190
18 x 16	18.00	16.00	36.00	36.00	28.00	23.62	18.50	3338
450 x 400	457	406	914	914	710	600	470	1500
20 x 16	20.00	16.00	39.00	39.00	30.70	24.40	20.07	3777
500 x 400	508	406	991	991	780	620	510	1700
20 x 18	20.00	18.00	39.00	39.00	30.40	24.40	20.07	4666
500 x 450	508	457	991	991	780	620	510	2100
24 x 20	24.00	20.00	45.00	45.00	36.00	25.10	19.68	(1)
600 x 500	610	508	1143	1143	915	637	500	(1)
30 x 24	30.00	24.00	55.00	55.00	42.90	25.80	21.20	(1)
750 x 600	762	610	1397	1397	1090	655	540	(1)
36 x 30	36.00	30.00	68.00	68.00	50.00	27.60	28.70	(1)
900 x 750	914	762	1727	1727	1270	700	730	(1)

With lever
With gear

*) Other dimension on request.

- Flanges in accordance with ASME B16.5
- Shaded bore sizes (D) according to API 6D

- Butt welding ends according to ASME B16.25
- Shaded end-to-end dimensions according to API 6D

Weight figures are relevant to flanged end valves. (1) Please consult the factory. Note. For dimensions and weights in larger sizes consult the factory. Dimensions B, C, D, E and weights are subject to change without notice.

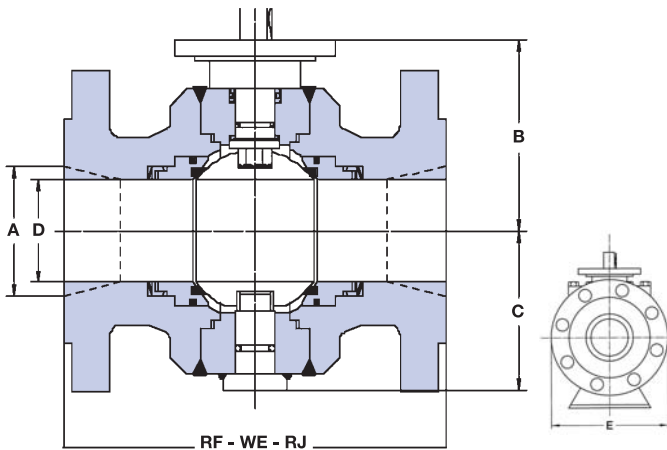

ASME CLASS 600 FULL BORE

SIZE IN/MM	WELDED BODY							WEIGHT LBS/KG
	D	RF	RJ	WE	E	B	C	
2	2.00	11.50	11.63	11.50	6.50	7.67	4.33	(1)
50	51	292	295	292	165	195	110	(1)
3	3.00	14.00	14.13	14.00	8.50	9.44	4.33	(1)
80	76	356	359	356	218	240	110	(1)
4	4.00	17.00	17.13	17.00	10.70	11.02	6.88	(1)
100	102	432	435	432	273	280	175	(1)
6	6.00	22.00	22.13	22.00	14.10	12.00	7.67	(1)
150	152	559	562	559	360	305	195	(1)
8	8.00	26.00	26.13	26.00	16.50	15.74	11.02	(1)
200	203	660	664	660	419	400	280	(1)
10	10.00	31.00	31.13	31.00	20.40	17.12	11.22	(1)
250	254	787	791	787	520	435	285	(1)
12	12.00	33.00	33.13	33.00	22.60	17.32	12.59	(1)
300	305	838	841	838	575	440	320	(1)
14	14.00	35.00	35.13	35.00	24.70	19.88	13.38	(1)
350	356	889	892	889	628	505	340	(1)
16	16.00	39.00	39.13	39.00	27.60	23.22	16.14	(1)
400	406	991	994	991	700	590	410	(1)
18	18.00	43.00	43.13	43.00	30.50	23.55	17.51	(1)
450	457	1092	1095	1092	775	589	445	(1)
20	20.00	47.00	47.25	47.00	34.10	23.80	20.07	(1)
500	508	1194	1200	1194	865	604	510	(1)
22	22.00	51.00	51.38	51.00	37.40	24.00	20.35	(1)
550	559	1296	1305	1296	950	609	571	(1)
24	24.00	55.00	55.38	55.00	40.50	24.50	25.19	(1)
600	610	1397	1406	1397	1028	622	640	(1)
26	26.00	57.00	57.50	57.00	40.10	24.80	24.30	(1)
650	660	1448	1460	1448	1020	630	618	(1)
28	28.00	61.00	61.50	61.00	46.10	26.20	27.20	(1)
700	711	1549	1562	1549	1172	665	692	(1)
30	30.00	66.30	65.50	66.30	50.80	29.20	31.50	(1)
750	762	1684	1697	1684	1290	741	800	(1)
32	32.00	70.00	70.72	70.00	52.40	29.80	31.70	(1)
800	813	1778	1794	1778	1330	756	804	(1)
34	34.00	76.00	76.52	76.00	57.10	30.80	32.20	(1)
850	864	1930	1946	1930	1450	782	817	(1)
36	36.00	82.00	82.63	82.00	60.90	34.20	37.20	(1)
900	914	2083	2098	2083	1546	869	945	(1)
40	40.00	85.40	85.43	85.40	64.80	36.10	38.60	(1)
1000	1016	2170	2170	2170	1645	916	980	(1)
42	42.00	85.60	85.63	85.60	70.80	39.20	43.70	(1)
1050	1067	2175	2175	2175	1800	995	1110	(1)
48	48.00	95.90	95.87	95.90	81.50	44.60	49.80	(1)
1200	1219	2435	2435	2435	2070	1132	1265	(1)
56	53.54	106.70	106.70	106.70	94.00	51.00	57.50	(1)
1400	1360	2710	2710	2710	2390	1290	1460	(1)

With lever
With gear

With lever
With gear

ASME CLASS 600 REDUCED BORE

SIZE IN/MM	WELDED BODY								WEIGHT LBS/KG
	A	D	RF	RJ	WE	E	B	C	
2 x 1/2	2.00	1.50	11.50	11.63	11.50	6.50	7.48	3.54	(1)
50 x 40	51	38	292	295	292	165	190	90	(1)
3 x 2	3.00	2.00	14.09	14.13	14.00	8.30	7.67	4.33	(1)
80 x 50	76	51	356	359	356	210	195	110	(1)
4 x 3	4.00	3.00	17.00	17.13	17.00	14.70	9.44	4.33	(1)
100 x 80	102	76	432	436	432	373	240	110	(1)
6 x 4	6.00	4.00	22.00	22.13	22.00	14.00	11.02	6.88	(1)
150 x 100	152	102	559	562	559	356	280	175	(1)
8 x 6	8.00	6.00	26.00	26.13	26.00	16.50	12.00	7.67	(1)
200 x 150	203	152	660	664	660	419	305	195	(1)
10 x 8	10.00	8.00	31.00	31.13	31.00	20.10	15.74	11.02	(1)
250 x 200	254	203	787	791	787	510	400	280	(1)
12 x 10	12.00	10.00	33.00	33.13	33.00	22.00	17.12	11.22	(1)
300 x 250	305	254	838	841	838	560	435	285	(1)
14 x 10	14.00	10.00	35.00	35.13	35.00	23.80	17.32	12.59	(1)
350 x 250	356	254	889	892	889	605	440	320	(1)
14 x 12	14.00	12.00	35.00	35.13	35.00	23.80	17.32	12.59	(1)
350 x 300	356	305	889	892	889	605	440	320	(1)
16 x 12	16.00	12.00	39.00	39.13	39.00	27.00	19.88	13.38	(1)
400 x 300	406	305	991	994	991	685	505	340	(1)
16 x 14	16.00	14.00	35.00	39.13	35.00	24.70	19.88	13.38	(1)
400 x 350	406	356	889	994	889	628	505	340	(1)
18 x 16	18.00	16.00	43.00	43.13	43.00	29.30	23.22	16.14	(1)
450 x 400	457	406	1092	1095	1092	745	590	410	(1)
20 x 16	20.00	16.00	47.00	47.25	47.00	32.10	23.80	17.51	(1)
500 x 400	508	406	1194	1200	1194	815	604	445	(1)
20 x 18	20.00	18.00	47.00	47.25	47.00	32.10	24.00	17.51	(1)
500 x 450	508	457	1194	1200	1194	815	609	445	(1)
24 x 20	24.00	20.00	55.00	55.38	55.00	37.00	24.50	20.07	(1)
600 x 500	610	508	1397	1406	1397	940	622	510	(1)
30 x 24	30.00	24.00	66.30	65.50	66.30	44.50	24.80	22.40	(1)
750 x 600	762	610	1684	1697	1684	1130	629	570	(1)
36 x 30	36.00	30.00	82.00	82.63	82.00	51.80	27.90	29.90	(1)
900 x 750	914	762	2083	2098	2083	1315	708	760	(1)

*) Other dimension on request.

- Flanges in accordance with ASME B16.5
- Shaded bore sizes (D) according to API 6D

- Butt welding ends according to ASME B16.25
- Shaded end-to-end dimensions according to API 6D

Weight figures are relevant to flanged end valves. (1) Please consult the factory. Note. For dimensions and weights in larger sizes consult the factory. Dimensions B, C, D, E and weights are subject to change without notice.



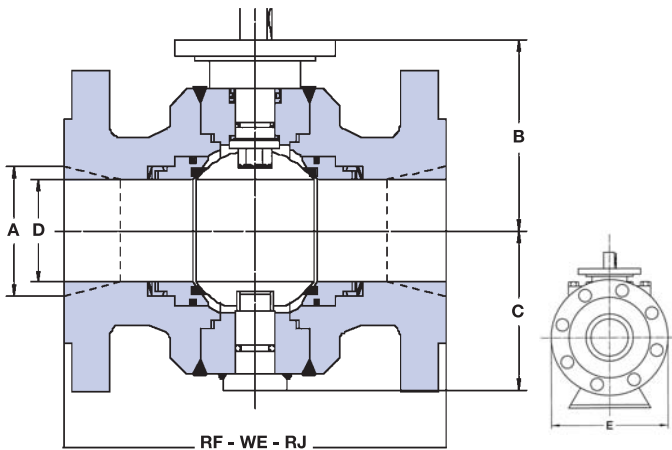

ASME CLASS 900 FULL BORE

SIZE IN/MM	WELDED BODY							WEIGHT LBS/KG
	D	RF	RJ	WE	E	B	C	
2	2.00	14.49	14.61	14.49	8.50	7.87	4.72	(1)
50	51	368	371	368	220	200	120	(1)
3	3.00	15.00	15.12	15.00	9.49	9.44	5.11	(1)
80	76	381	384	381	241	240	130	(1)
4	4.00	17.99	18.11	17.99	11.50	11.02	6.88	(1)
100	102	457	460	457	290	280	175	(1)
6	6.00	24.02	24.13	24.02	15.00	13.77	8.66	(1)
150	152	610	613	610	381	350	220	(1)
8	8.00	29.02	29.13	29.02	18.50	15.35	10.23	(1)
200	203	737	740	737	470	390	260	(1)
10	10.00	32.99	33.11	32.99	21.46	18.89	14.20	(1)
250	254	838	841	838	545	480	310	(1)
12	12.00	37.99	38.11	37.99	24.02	17.24	16.14	(1)
300	305	965	968	965	610	438	410	(1)
14	14.00	40.51	40.87	40.51	25.50	21.45	14.56	(1)
350	356	1029	1038	1029	650	545	370	(1)
16	16.00	44.49	44.88	44.49	27.95	24.59	16.53	(1)
400	406	1130	1140	1130	710	624	420	(1)
18	18.00	47.99	48.50	47.99	31.50	24.80	24.29	(1)
450	457	1219	1232	1219	800	630	617	(1)
20	20.00	52.01	52.48	52.01	35.04	25.00	28.54	(1)
500	508	1321	1333	1321	890	635	725	(1)
24	24.00	60.98	61.73	60.98	41.69	26.00	32.71	(1)
600	610	1549	1568	1549	1059	660	831	(1)
28	28.00	69.02	69.88	69.02	48.58	26.54	27.80	(1)
700	711	1753	1775	1753	1234	674	706	(1)
30	30.00	74.02	74.88	74.02	51.18	28.50	30.59	(1)
750	762	1880	1902	1880	1300	725	777	(1)
32	32.00	80.00	80.87	80.00	53.43	30.87	31.90	(1)
800	813	2032	2054	2032	1357	784	810	(1)
34	34.00	85.00	86.14	85.00	57.80	31.77	33.54	(1)
850	864	2159	2188	2159	1468	807	852	(1)
36	36.00	90.00	91.14	90.00	60.31	33.39	35.35	(1)
900	914	2286	2315	2286	1532	848	898	(1)

• Other dimension on request.

ASME CLASS 900 REDUCED BORE

SIZE IN/MM	WELDED BODY								WEIGHT LBS/KG
	A	D	RF	RJ	WE	E	B	C	
2 x 1/2	2.00	1.50	14.49	14.61	14.49	8.60	6.10	4.25	(1)
50 x 40	51	38	368	371	368	220	155	108	(1)
3 x 2	3.00	2.00	15.00	15.12	15.00	9.49	7.87	4.72	(1)
80 x 50	76	51	381	384	381	241	200	120	(1)
4 x 3	4.00	3.00	17.99	18.11	17.99	11.50	9.44	5.11	(1)
100 x 80	102	76	457	460	457	290	240	130	(1)
6 x 4	6.00	4.00	24.02	24.13	24.02	14.90	11.02	6.88	(1)
150 x 100	152	102	610	613	610	380	280	175	(1)
8 x 6	8.00	6.00	29.02	29.13	29.02	18.50	13.77	8.66	(1)
200 x 150	203	152	737	740	737	470	350	220	(1)
10 x 8	10.00	8.00	32.99	33.11	32.99	21.46	15.35	10.23	(1)
250 x 200	254	203	838	841	838	545	390	260	(1)
12 x 10	12.00	10.00	37.99	38.11	37.99	24.02	18.89	12.20	(1)
300 x 250	305	254	965	968	965	610	480	310	(1)
14 x 10	14.00	10.00	40.51	40.87	40.51	25.50	17.24	16.14	(1)
350 x 250	356	254	1029	1038	1029	650	438	410	(1)
14 x 12	14.00	12.00	40.51	40.87	40.51	27.90	17.24	16.14	(1)
350 x 300	356	305	1029	1038	1029	710	438	410	(1)
16 x 12	16.00	12.00	44.49	44.88	44.49	29.50	21.45	14.56	(1)
400 x 300	406	305	1130	1140	1130	750	545	370	(1)
16 x 14	16.00	14.00	44.49	44.88	44.49	31.10	21.45	14.56	(1)
400 x 350	406	356	1130	1140	1130	790	545	370	(1)
18 x 16	18.00	16.00	47.99	48.50	47.99	31.50	24.59	16.53	(1)
450 x 400	457	406	1219	1232	1219	800	624	420	(1)
20 x 16	20.00	16.00	52.01	52.48	52.01	31.10	25.00	24.29	(1)
500 x 400	508	406	1321	1333	1321	790	630	617	(1)
20 x 18	20.00	18.00	52.01	52.48	52.01	35.04	25.57	24.29	(1)
500 x 450	508	457	1321	1333	1321	890	649	617	(1)
24 x 20	24.00	20.00	60.98	61.73	60.98	40.94	25.70	28.54	(1)
600 x 500	610	508	1549	1568	1549	1040	652	725	(1)
30 x 24	30.00	24.00	74.02	74.88	74.02	48.43	28.00	24.88	(1)
750 x 600	762	610	1880	1902	1880	1230	711	632	(1)
36 x 30	36.00	30.00	90.00	91.14	90.00	57.48	31.70	30.87	(1)
900 x 750	914	762	2286	2315	2286	1460	807	784	(1)

• Other dimension on request.

- Flanges in accordance with ASME B16.5
- Shaded bore sizes (D) according to API 6D

- Butt welding ends according to ASME B16.25
- Shaded end-to-end dimensions according to API 6D

Weight figures are relevant to flanged end valves. (1) Please consult the factory. Note. For dimensions and weights in larger sizes consult the factory. Dimensions B, C, D, E and weights are subject to change without notice.

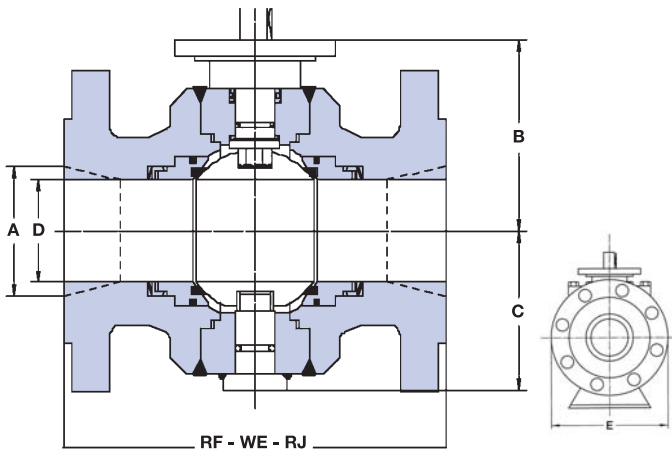

ASME CLASS 1500 FULL BORE

SIZE IN/MM	WELDED BODY							WEIGHT LB/KG
	D	RF	RJ	WE	E	B	C	
2	2.00	14.49	14.61	14.49	8.60	8.07	4.72	(1)
50	51	368	371	368	220	205	120	
3	3.00	18.50	18.62	18.50	10.51	8.26	4.92	(1)
80	76	473	473	470	267	210	125	
4	4.00	21.50	21.61	21.50	12.20	9.64	6.29	(1)
100	102	546	549	546	310	245	160	
6	6.00	27.76	27.99	27.76	15.51	13.18	10.03	(1)
150	152	705	711	705	394	335	255	
8	8.00	32.76	33.11	32.76	19.09	17.20	13.38	(1)
200	203	832	841	832	485	437	340	
10	10.00	39.02	39.37	39.02	23.03	19.76	15.00	(1)
250	254	991	1000	991	585	502	381	
12	12.00	44.49	44.61	44.49	27.95	20.98	17.24	(1)
300	305	1130	1133	1130	710	533	438	
14	14.00	49.49	50.24	49.49	30.12	24.64	19.60	(1)
350	356	1257	1276	1257	765	626	498	
16	16.00	54.49	55.35	54.49	33.39	28.54	18.11	(1)
400	406	1384	1406	1384	848	725	460	
18	18.00	60.51	61.38	60.51	38.58	29.00	23.90	(1)
450	457	1537	1559	1537	980	736	607	
20	20.00	65.51	66.38	65.51	39.96	30.00	25.40	(1)
500	508	1664	1686	1664	1015	762	644	
24	24.00	80.43	81.54	80.43	50.91	32.00	28.50	(1)
600	610	2043	2071	2043	1295	813	725	

With lever
With gear

With lever
With gear

• Other dimension on request.

ASME CLASS 1500 REDUCED BORE

SIZE IN/MM	WELDED BODY							WEIGHT LB/KG	
	A	D	RF	RJ	WE	E	B		C
2 x 1/2	2.00	1.50	14.49	14.61	14.49	8.66	7.48	4.33	(1)
50 x 40	51	38	368	371	368	220	190	110	
3 x 2	3.00	2.00	18.50	18.62	18.50	10.51	8.07	4.72	(1)
80 x 50	76	51	470	473	470	2.67	205	120	
4 x 3	4.00	3.00	21.50	21.61	21.50	12.20	8.26	4.92	(1)
100 x 80	102	76	546	549	546	310	210	125	
6 x 4	6.00	4.00	27.76	27.99	27.76	15.51	9.64	6.29	(1)
150 x 100	152	102	705	711	705	394	245	160	
8 x 6	8.00	6.00	32.76	33.11	32.76	19.09	13.18	10.03	(1)
200 x 150	203	152	832	841	832	485	335	255	
10 x 8	10.00	8.00	39.02	39.37	39.02	23.03	16.14	11.41	(1)
250 x 200	254	203	991	1000	991	585	410	290	
12 x 10	12.00	10.00	44.49	45.12	44.49	26.57	18.30	13.18	(1)
300 x 250	305	254	1130	1146	1130	675	465	335	
14 x 10	14.00	10.00	49.49	50.24	49.49	27.95	21.77	17.24	(1)
350 x 250	356	254	1257	1276	1257	710	553	439	
14 x 12	14.00	12.00	49.49	50.24	49.49	29.92	21.77	17.24	(1)
350 x 300	356	305	1257	1276	1257	760	553	438	
16 x 12	16.00	12.00	54.59	55.35	54.49	32.48	24.64	19.60	(1)
400 x 300	406	305	1384	1406	1384	825	626	498	
16 x 14	16.00	14.00	54.49	55.35	54.49	32.48	24.64	19.60	(1)
400 x 350	406	356	1384	1406	1384	825	626	498	
18 x 16	18.00	16.00	60.51	61.38	60.51	36.22	25.00	20.00	(1)
450 x 400	457	406	1537	1559	1537	920	630	508	
20 x 16	20.00	16.00	65.51	66.38	65.51	38.97	26.00	20.00	(1)
500 x 400	508	406	1664	1686	1664	990	660	508	
20 x 18	20.00	18.00	65.52	66.38	65.51	38.97	28.00	23.00	(1)
500 x 450	508	457	1664	1686	1664	990	711	542	
24 x 20	24.00	20.00	80.43	81.54	80.43	46.06	30.00	25.00	(1)
600 x 500	610	508	2043	2071	2043	1170	762	635	

• Other dimension on request.

- Flanges in accordance with ASME B16.5
- Shaded bore sizes (D) according to API 6D

- Butt welding ends according to ASME B16.25
- Shaded end-to-end dimensions according to API 6D

Weight figures are relevant to flanged end valves. (1) Please consult the factory. Note. For dimensions and weights in larger sizes consult the factory. Dimensions B, C, D, E and weights are subject to change without notice.



API 6A

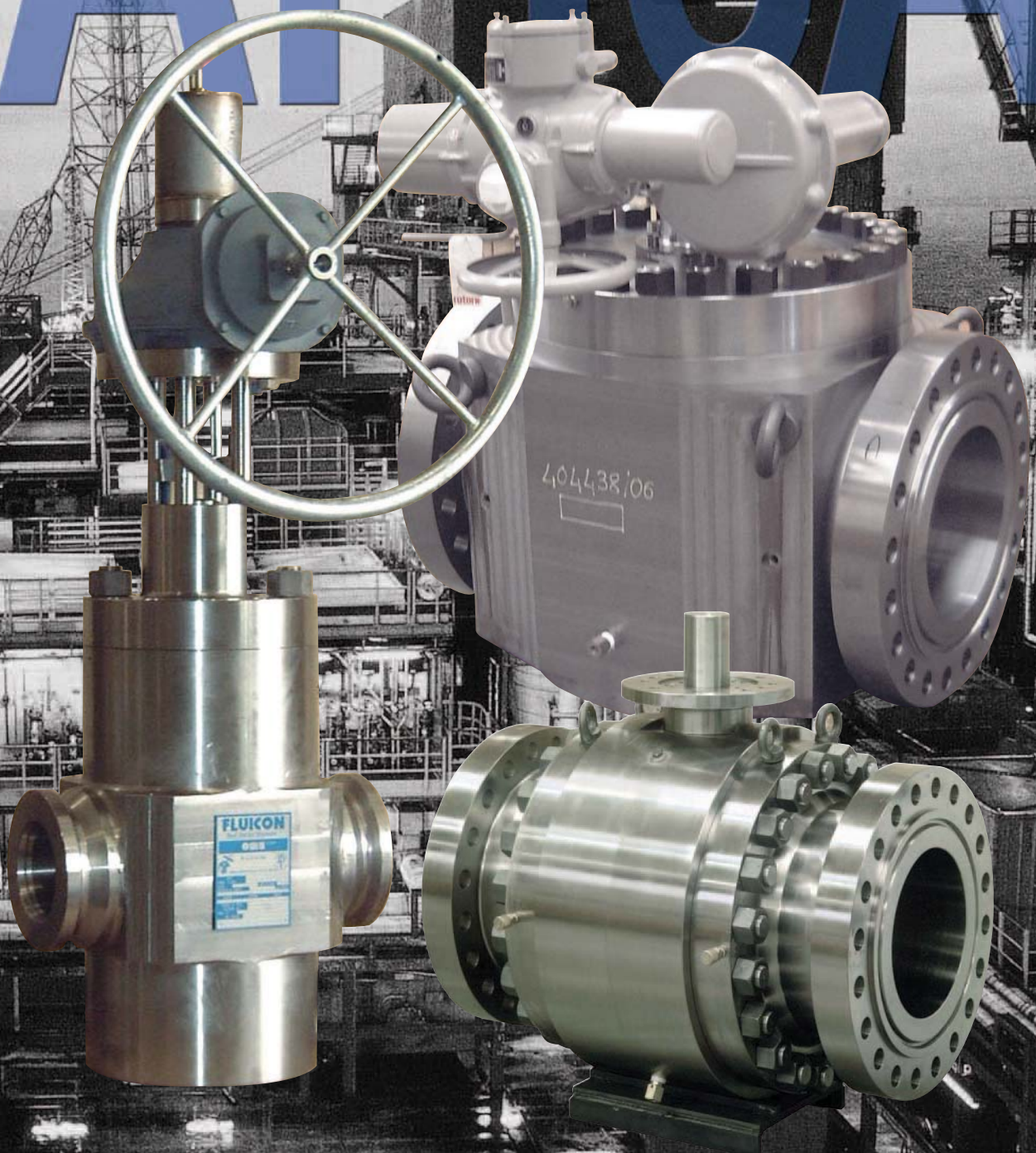

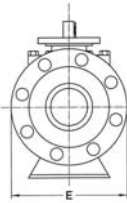
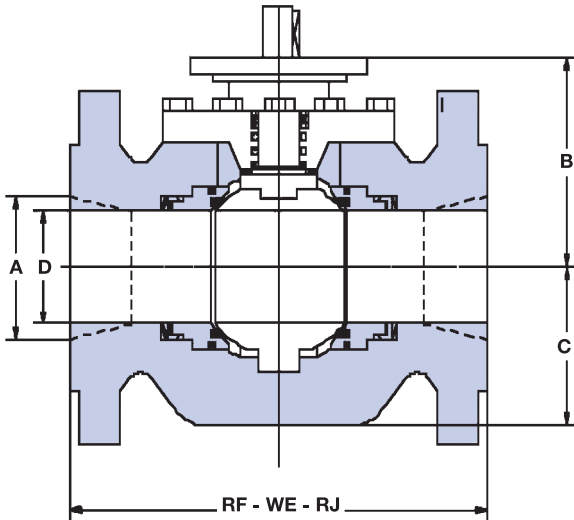

CLASS API 3000 FULL BORE

SIZE IN/MM	TOP ENTRY					WEIGHT LBS/KG
	D	RJ	E	B	C	
2 1/16 50	2.06 52.4	14.61 371	8.50 216	6.50 165	4.33 110	(1)
3 1/8 80	3.12 79.3	17.13 435	9.44 240	7.87 200	5.00 150	(1)
4 1/16 100	4.06 103.2	20.12 511	11.80 300	8.27 210	6.69 170	(1)
5 1/8 125	5.12 130	24.13 613	16.65 423	10.83 275	10.16 258	(1)
7 1/16 200	7.06 179.4	28.11 714	15.00 380	13.78 350	13.39 340	(1)

CLASS API 3000 REDUCED BORE

SIZE IN/MM	TOP ENTRY						WEIGHT LBS/KG
	A	D	RJ	E	B	C	
2 1/16 x 1 1/16 50 x 40	2.06 52.4	2.06 52.4	14.61 371	8.50 216	6.50 165	4.33 110	(1)
3 1/8 x 2 1/16 80 x 50	3.12 79.3	3.12 79.3	17.13 435	9.49 240	7.87 200	5.90 150	(1)
4 1/16 x 3 1/8 100 x 80	4.06 103.2	4.06 103.2	20.12 511	11.61 300	8.27 210	6.69 170	(1)
5 1/8 x 4 1/16 125 x 150	5.12 130	5.12 130	24.13 613	16.65 423	10.83 275	10.16 258	(1)
7 1/16 x 6 200 x 150	7.06 179.4	7.06 179.4	28.11 714	15.00 381	13.78 350	13.39 340	(1)

CLASS API 5000 FULL BORE

SIZE IN/MM	TOP ENTRY					WEIGHT LBS/KG
	D	RJ	E	B	C	
2 1/16 50	2.06 52.4	14.61 371	8.50 216	6.50 165	4.33 110	(1)
3 1/8 80	3.12 79.3	17.13 435	9.44 240	7.87 200	5.90 150	(1)
4 1/16 100	4.06 103.2	20.12 511	11.80 300	8.27 210	6.69 170	(1)
5 1/8 125	5.12 130	24.13 613	16.65 423	10.83 275	10.16 258	(1)
7 1/16 200	7.06 179.4	28.11 714	15.00 380	13.78 350	13.39 340	(1)

CLASS API 5000 REDUCED BORE

SIZE IN/MM	TOP ENTRY						WEIGHT LBS/KG
	A	D	RJ	E	B	C	
2 1/16 x 1 1/16 50 x 40	2.06 52.4	2.06 52.4	14.61 371	8.50 216	6.50 165	4.33 110	(1)
3 1/8 x 2 1/16 80 x 50	3.12 79.3	3.12 79.3	17.13 435	9.44 240	7.87 200	5.90 150	(1)
4 1/16 x 3 1/8 100 x 80	4.06 103.2	4.06 103.2	20.12 511	11.80 300	8.27 210	6.69 170	(1)
5 1/8 x 4 1/16 125 x 150	5.12 130	5.12 130	24.13 613	16.65 423	10.83 275	10.16 258	(1)
7 1/16 x 6 200 x 150	7.06 179.4	7.06 179.4	28.11 714	14.90 380	13.78 350	13.39 340	(1)

CLASS API 10000 FULL BORE

SIZE IN/MM	TOP ENTRY					WEIGHT LBS/KG
	D	RJ	E	B	C	
2 1/16 50	2.06 52.4	14.61 371	8.50 216	6.50 165	4.33 110	(1)
3 1/8 80	3.12 79.3	17.13 435	9.44 240	7.87 200	5.90 150	(1)
4 1/16 100	4.06 103.2	20.12 511	11.80 300	8.27 210	6.69 170	(1)

CLASS API 10000 REDUCED BORE

SIZE IN/MM	TOP ENTRY						WEIGHT LBS/KG
	A	D	RJ	E	B	C	
2 1/16 x 1 1/16 50 x 40	2.06 52.4	2.06 52.4	14.61 371	8.50 216	6.50 165	4.33 110	(1)
3 1/8 x 2 1/16 80 x 50	3.12 79.3	3.12 79.3	17.13 435	9.44 240	7.87 200	5.90 150	(1)
4 1/16 x 3 1/8 100 x 80	4.06 103.2	4.06 103.2	20.12 511	11.80 300	8.27 210	6.69 170	(1)

API 6A GATE GLOBE CHECK VALVES SEE API 6A/API 6D CATALOG

- Flanges in accordance with ASME B16.5
- Shaded bore sizes (D) according to API 6A

- Butt welding ends according to ASME B16.25
- Shaded end-to-end dimensions according to API 6A

Weight figures are relevant to flanged end valves. (1) Please consult the factory. Note. For dimensions and weights in larger sizes consult the factory. Dimensions B, C, D, E and weights are subject to change without notice.



METAL TO METAL VALVES



SUB MARINE VALVES



MODULAR VALVES

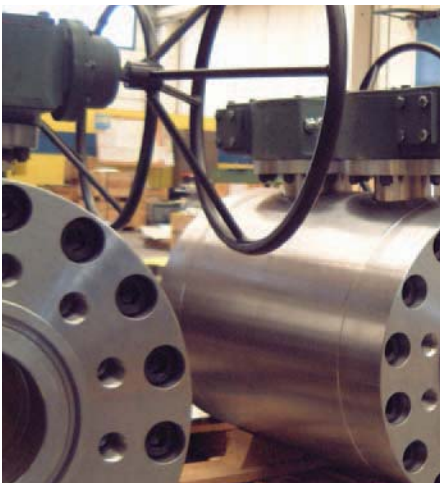

BURIED & CRYOGENIC VALVES



ACTUATED VALVES

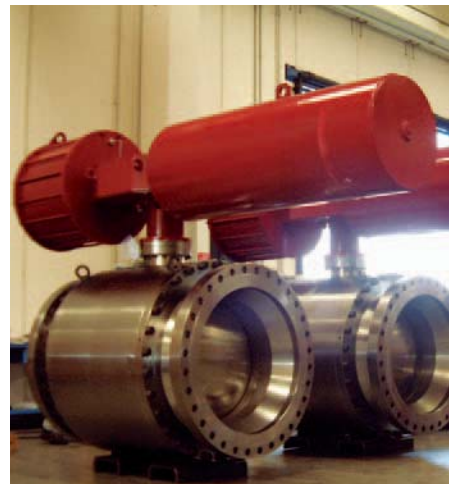

SPECIAL



FBE LINED



INCONEL 625 CLAD



PUP PIECES

GENZAK

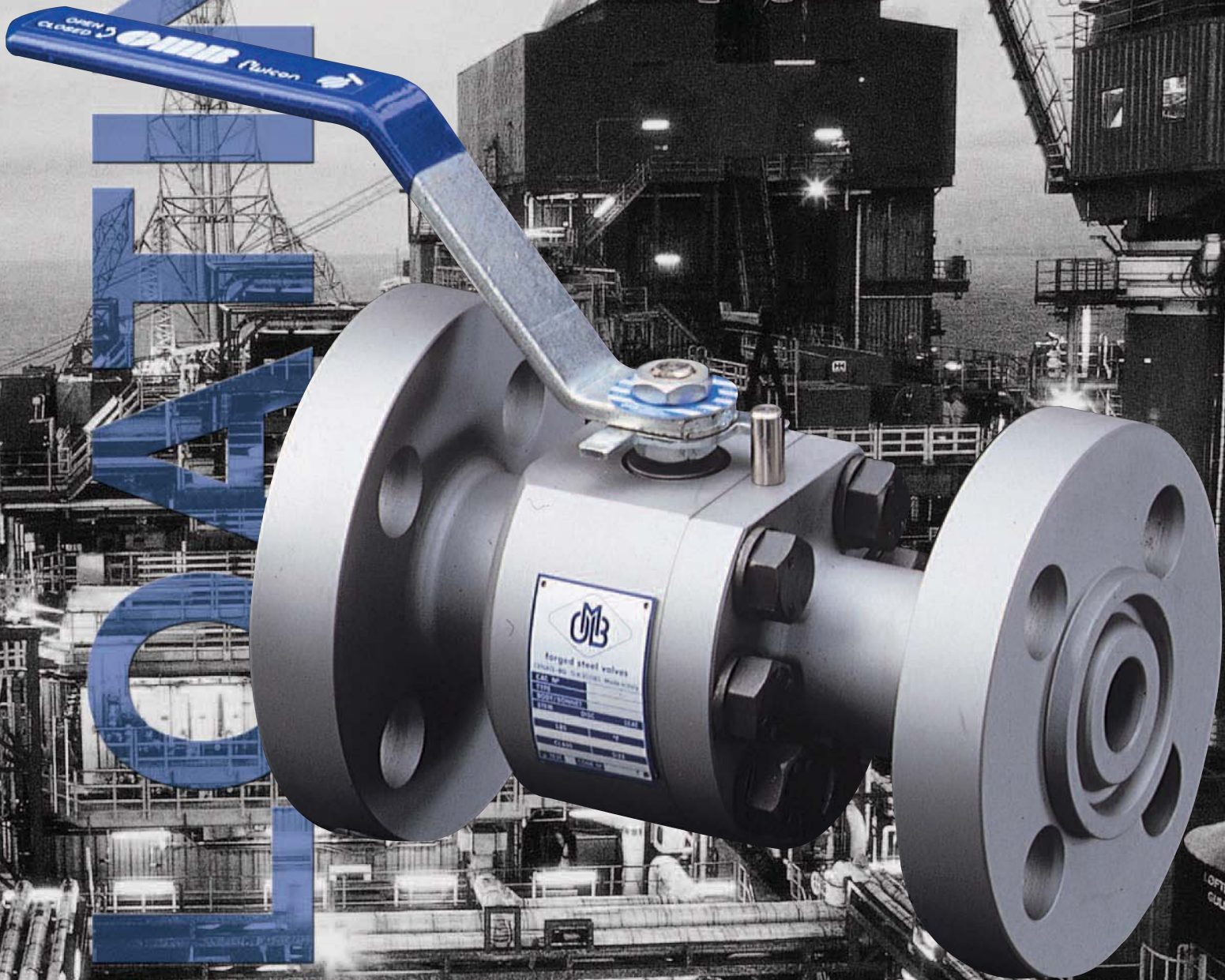

Floating Construction

Class Diameter	Class 150 RB - FB		Class 300 RB - FB		Class 600 RB - FB		Class 1500 RB - FB		Class 2500 RB - FB	
1/2"	●	○	●	○	●	○	●	○	●	○
3/4"	●	○	●	○	●	○	●	○	●	○
1"	●	○	●	○	●	○	●	○	●	
1 1/2"	●	○	●	○	●	○	●			
2"	●	○	●	○	●	○				
3"	●	○	●	○	●	○				
4"	●	○	●	○	●	○				
6"	●	○	●	○	●	○				
8"	●		●		●					
10"										
12"										

COATING REDUCED BORE



METAL TO METAL

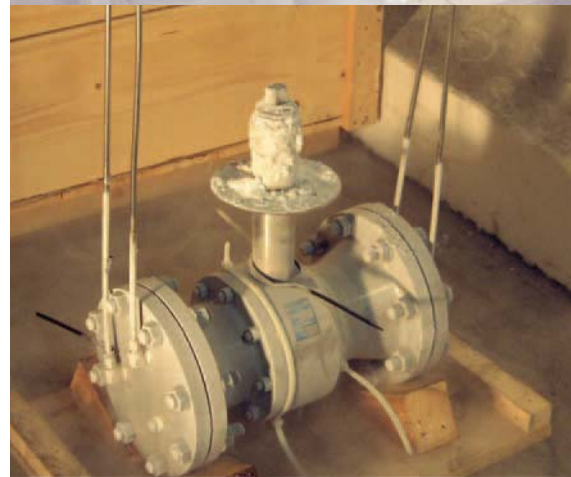

CRYOGENIC

FEATURES

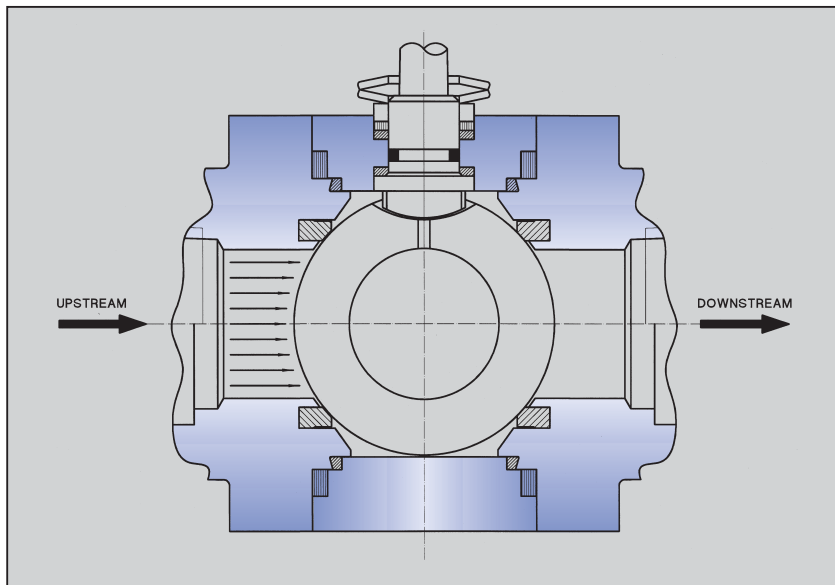

JACKETED



ACTUATED



Without prior notice OMB reserves the right to make modifications or changes to its production.





ONE PIECE BODY - FLOATING REDUCED BORE

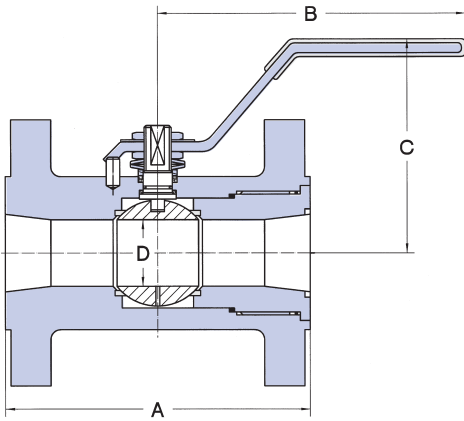

CLASS 150 REGULAR BORE END ENTRY ONE PIECE BALL VALVES BODY

Integral Flanged - End According to ANSI 16.10

REGULAR BORE	F1-E-800	1/2" x 3/8"		3/4" x 1/2"		1" x 3/4"		1.1/2" x 1.1/4"		2" x 1.1/2"	
		mm	in.	mm	in.	mm	in.	mm	in.	mm	in.
End to End	A	108	4.25	118	4.62	127	5.00	165	6.50	178	7.00
Lever	B	155	6.10	155	6.10	170	6.69	230	9.05	230	9.05
Center to Top	C	74	2.91	76	2.99	98	3.85	119	4.68	130	5.11
Ball Bore	D	11.1	0.43	14.2	0.55	20.5	0.80	31.7	1.24	38	1.49
Approx. Weight	Kg/Lb	1.5	3.3	2.4	5.2	3.5	7.7	6.5	14.3	8.3	16.2

CLASS 300 REGULAR BORE END ENTRY ONE PIECE BALL VALVES BODY

Integral Flanged - End According to ANSI 16.10

REGULAR BORE	F3-E-800	1/2" x 3/8"		3/4" x 1/2"		1" x 3/4"		1.1/2" x 1.1/4"		2" x 1.1/2"	
		mm	in.	mm	in.	mm	in.	mm	in.	mm	in.
End to End	A	140	5.5	153	6.0	165	6.5	191	7.5	216	8.5
Lever	B	155	6.1	155	6.1	170	6.69	230	9.05	230	9.05
Center to Top	C	74	2.91	76	2.99	98	3.85	119	4.68	130	5.11
Ball Bore	D	11.1	0.43	14.2	0.55	20.5	0.80	31.7	1.24	38	1.49
Approx. Weight	Kg/Lb	2.5	5.5	3.1	6.8	4.0	8.8	8.1	17.8	10.2	22.4

CLASS 600 REGULAR BORE END ENTRY ONE PIECE BALL VALVES BODY

Integral Flanged - End According to ANSI 16.10

REGULAR BORE	F6-E-800	1/2" x 3/8"		3/4" x 1/2"		1" x 3/4"		1.1/2" x 1.1/4"		2" x 1.1/2"	
		mm	in.	mm	in.	mm	in.	mm	in.	mm	in.
End to End	A	165	6.5	191	7.5	216	8.5	241	9.5	292	11.5
Lever	B	155	6.1	155	6.1	170	6.69	230	9.05	230	9.05
Center to Top	C	74	2.91	76	2.99	98	3.85	119	4.68	130	5.11
Ball Bore	D	11.1	0.43	14.2	0.55	20.5	0.80	31.7	1.24	38	1.49
Approx. Weight	Kg/Lb	2.9	6.3	3.8	8.3	5.3	11.6	10.6	23.3	13	28.6

Weight figures are relevant to flanged end valves. (1) Please consult the factory. Note. For dimensions and weights in larger sizes consult the factory. Dimensions B, C, RF and weights are subject to change without notice.



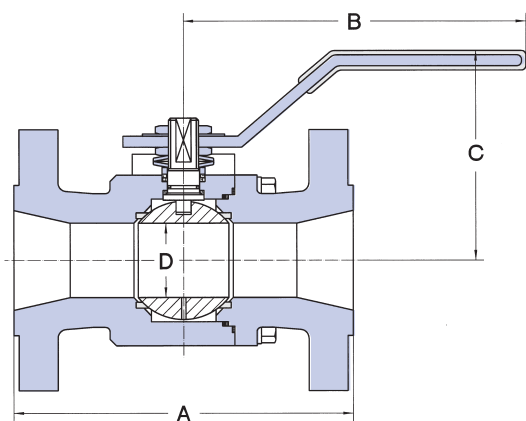

CLASS 150 REGULAR BORE SIDE ENTRY TWO PIECE BALL VALVES BODY

Integral Flanged - End According to ANSI 16.10

REGULAR BORE	F1-C-800	2" x 1.1/2"		4" x 3"		6" x 4"		8" x 6"	
		mm	in.	mm	in.	mm	in.	mm	in.
End to End	A	178	7.00	229	9.0	394	10.53	457	11.50
Lever	B	310	12.20	450	17.71	465	18.30	*	*
Center to Top	C	155	6.10	184	7.24	223	8.78	247	9.72
Ball Bore	D	38	1.49	76	2.99	127	5.00	152	5.98
Approx. Weight	Kg/Lb	-	-	27.1	59.6	47.2	103.9	77.5	170.7

* Gear operator suggested

CLASS 300 REGULAR BORE END ENTRY TWO PIECE BALL VALVES BODY

Integral Flanged - End According to ANSI 16.10

REGULAR BORE	F3-C-800	2" x 1.1/2"		4" x 3"		6" x 4"		8" x 6"	
		mm	in.	mm	in.	mm	in.	mm	in.
End to End	A	216	8.50	305	12.00	403	15.88	419	16.50
Lever	B	310	12.20	450	17.71	465	18.30	*	*
Center to Top	C	155	6.10	184	7.24	223	8.78	247	9.72
Ball Bore	D	38	1.49	76	2.99	127	5.00	152	5.98
Approx. Weight	Kg/Lb	-	-	41.5	91.4	77.9	171.5	125	275.3

* Gear operator suggested

CLASS 600 REGULAR BORE END ENTRY TWO PIECE BALL VALVES BODY

Integral Flanged - End According to ANSI 16.10

REGULAR BORE	F6-C-800	2" x 1.1/2"		4" x 3"		6" x 4"		8" x 6"	
		mm	in.	mm	in.	mm	in.	mm	in.
End to End	A	292	11.50	432	17.00	559	22.00	660	26.00
Lever	B	310	12.20	450	17.71	685	26.96	*	*
Center to Top	C	155	6.10	200	7.87	245	9.64	405	15.94
Ball Bore	D	38	1.49	76	2.99	127	5.00	152	5.98
Approx. Weight	Kg/Lb	-	-	55.3	121.8	102.0	224.6	184.6	406.6

* Gear operator suggested

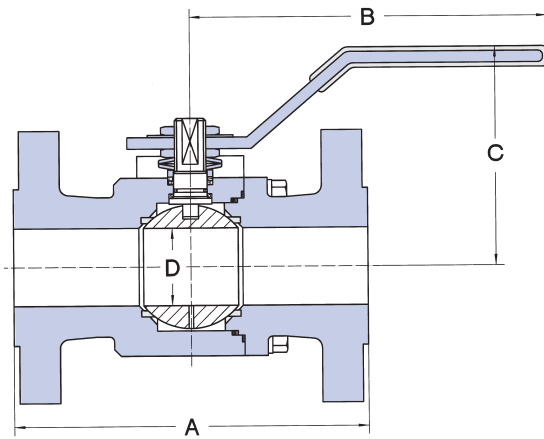

CLASS 150 FULL BORE SIDE ENTRY TWO PIECE BALL VALVES BODY

Integral Flanged - End According to ANSI 16.10

FULL BORE	F1-C-600	1/2"		3/4"		1"		1.1/2"		2"		3"		4"		6"	
		mm	in.	mm	in.	mm	in.	mm	in.	mm	in.	mm	in.	mm	in.	mm	in.
End to End	A	108	4.25	118	4.63	127	5.00	165	6.50	178	7.00	203	8.00	229	9.00	394	15.50
Lever	B	155	6.10	170	6.69	170	6.69	230	9.05	310	12.20	450	17.71	465	18.30	*	*
Center to Top	C	76	2.99	98	3.85	100	3.93	130	5.11	155	6.10	184	7.24	215	8.46	279	10.98
Ball Bore	D	14.2	0.55	20.5	0.80	25.4	1.00	38	1.49	51	2.00	76	2.99	102	4.01	152	5.98
Approx. Weight	Kg/Lb	2.1	4.6	3.7	8.1	4.7	10.3	9.1	20.0	12.0	26.4	22.0	48.5	38.2	84.1	93.0	204.8

* Gear operator suggested

CLASS 300 FULL BORE SIDE ENTRY TWO PIECE BALL VALVES BODY

Integral Flanged - End According to ANSI 16.10

FULL BORE	F1-C-600	1/2"		3/4"		1"		1.1/2"		2"		3"		4"		6"	
		mm	in.	mm	in.	mm	in.	mm	in.	mm	in.	mm	in.	mm	in.	mm	in.
End to End	A	140	5.50	153	6.00	165	6.50	191	7.50	216	8.50	283	11.13	305	12.00	-	-
Lever	B	155	6.10	170	6.69	170	6.69	230	9.05	310	12.20	450	17.71	*	*	-	-
Center to Top	C	76	2.99	98	3.85	100	3.93	130	5.11	155	6.10	184	7.24	215	8.46	-	-
Ball Bore	D	14.2	0.55	20.5	0.80	25.4	1.00	38	1.49	51	2.00	76	2.99	102	4.01	-	-
Approx. Weight	Kg/Lb	3.1	6.8	4.4	9.6	5.2	11.4	10.7	23.5	13.9	30.6	29.5	64.9	50.3	110.8	-	-

* Gear operator suggested

CLASS 600 FULL BORE SIDE ENTRY TWO PIECE BALL VALVES BODY

Integral Flanged - End According to ANSI 16.10

FULL BORE	F1-C-600	1/2"		3/4"		1"		1.1/2"		2"		3"		4"		6"	
		mm	in.	mm	in.	mm	in.	mm	in.	mm	in.	mm	in.	mm	in.	mm	in.
End to End	A	165	6.50	191	7.50	216	8.50	241	9.50	292	11.50	356	14.00	432	17.00	-	-
Lever	B	155	6.10	170	6.69	170	6.69	230	9.05	310	12.20	450	17.71	*	*	-	-
Center to Top	C	76	2.99	78	3.85	100	3.93	130	5.11	155	6.10	200	7.87	244	9.60	-	-
Ball Bore	D	14.2	0.55	20.5	0.80	25.4	1.00	38	1.49	51	2.00	76	2.99	102	4.01	-	-
Approx. Weight	Kg/Lb	3.5	7.7	5.1	11.2	6.5	14.3	13.21	29.0	16.7	36.7	34.0	74.8	48.6	107.0	-	-

* Gear operator suggested

CLASS 1500 FULL BORE SIDE ENTRY TWO PIECE BALL VALVES BODY

Integral Flanged - End According to ANSI 16.10

FULL BORE	F1-C-600	1/2"		3/4"		1"		1.1/2"		2"		3"		4"		6"	
		mm	in.	mm	in.	mm	in.	mm	in.	mm	in.	mm	in.	mm	in.	mm	in.
End to End	A	216	8.50	229	9.00	254	10.0	305	12.0	368	14.48	-	-	-	-	-	-
Lever	B	170	6.69	170	6.69	230	9.05	310	12.20	450	18.00	-	-	-	-	-	-
Center to Top	C	98	3.85	100	3.93	119	4.68	155	6.10	210	8.00	-	-	-	-	-	-
Ball Bore	D	14.2	0.55	20.5	0.80	25.4	1.00	38	1.49	51	2.00	-	-	-	-	-	-
Approx. Weight	Kg/Lb	8.5	18.7	11.0	24.2	16.0	35.2	30	66	45	1.00	-	-	-	-	-	-

* Gear operator suggested

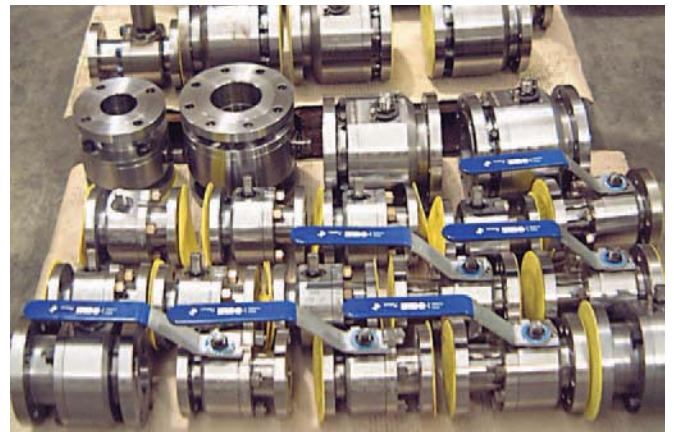
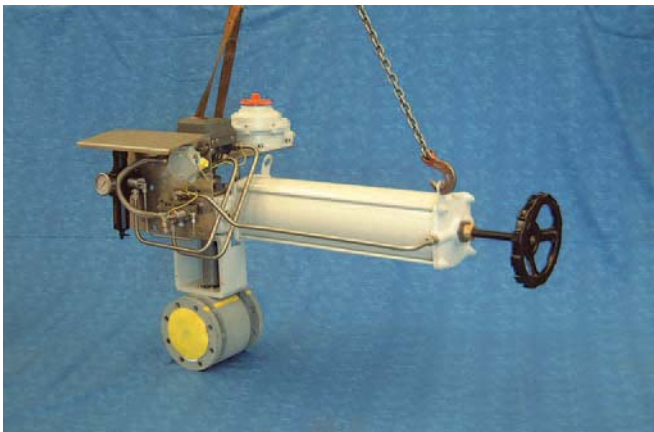
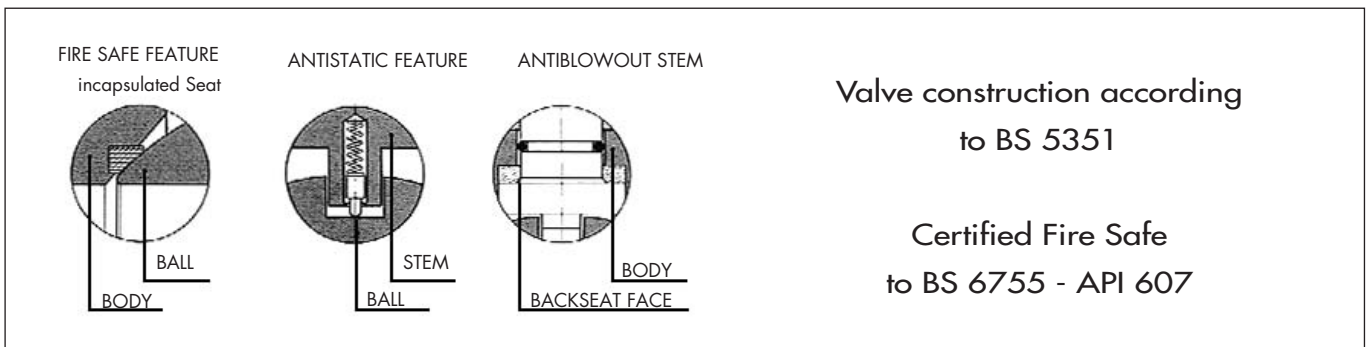
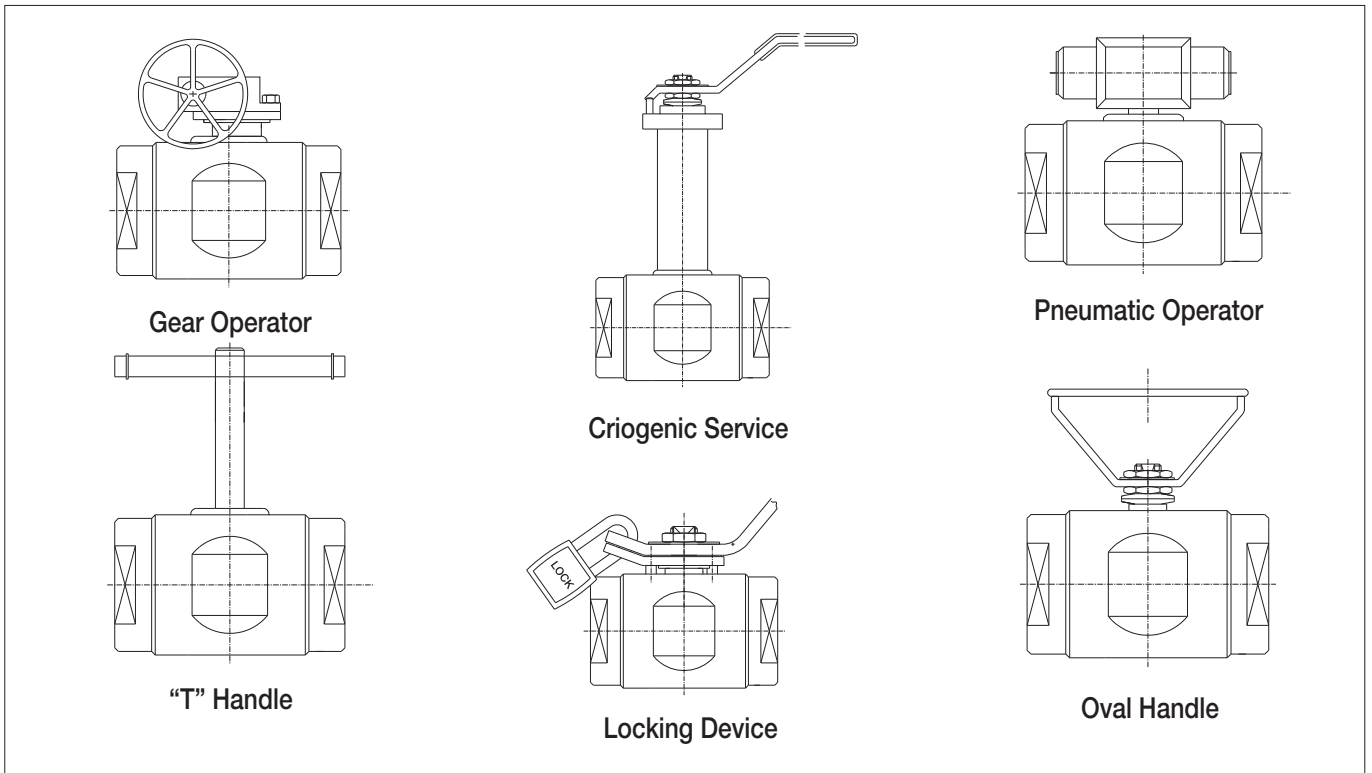

OMB offers a complete range of ball valves for low temperature and cryogenic service. We offer valves floating type with end entry, side entry and top entry design from $\frac{1}{2}$ " to 8" and trunnion mounted type with side and top entry design from $\frac{1}{2}$ " to 24". Our engineers have developed this complete range taking in consideration the demanding requirement of the major LNG producers which we have successfully supplied in the past years. Our laboratories are capable of complete and accurate testing as you will see in the following pages.

FLOATING SIDE ENTRY

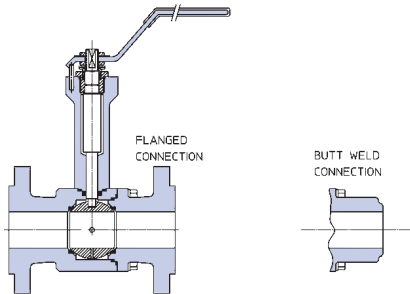

FLOATING TOP ENTRY

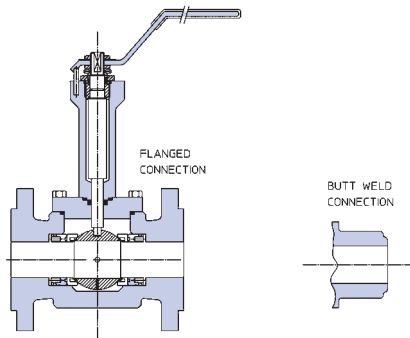

TRUNNION SIDE ENTRY

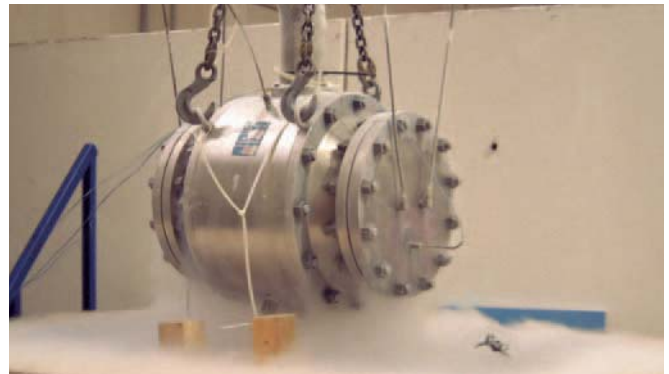
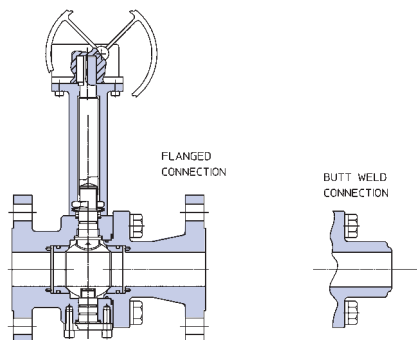

TRUNNION TOP ENTRY

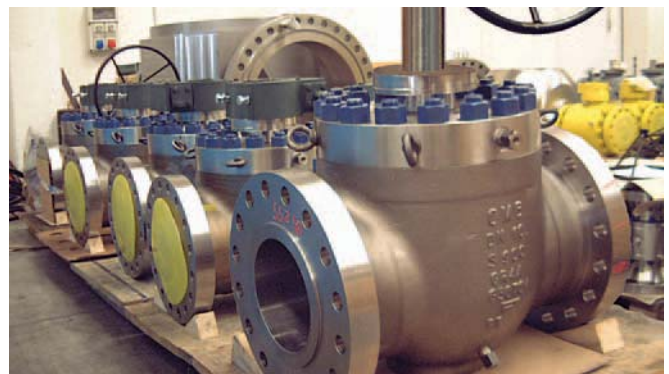
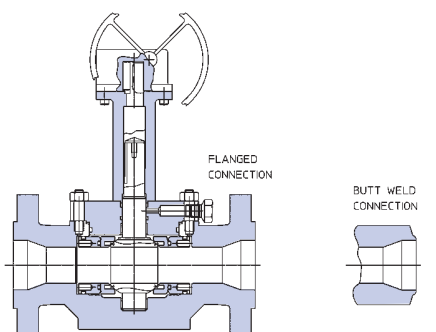

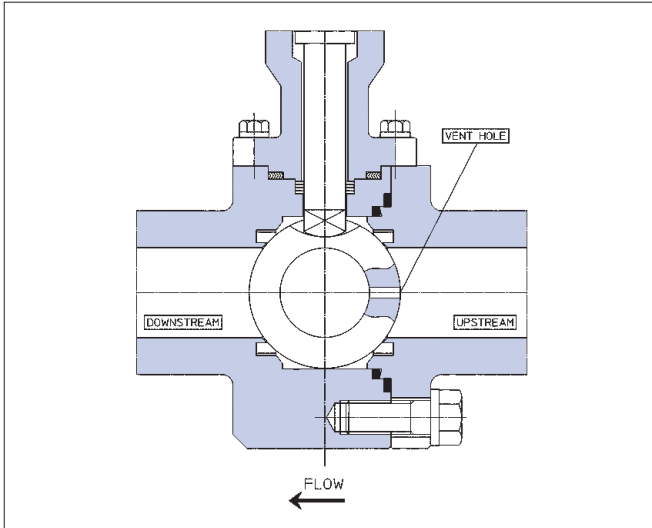

FLOATING BALL VALVE VENT HOLE

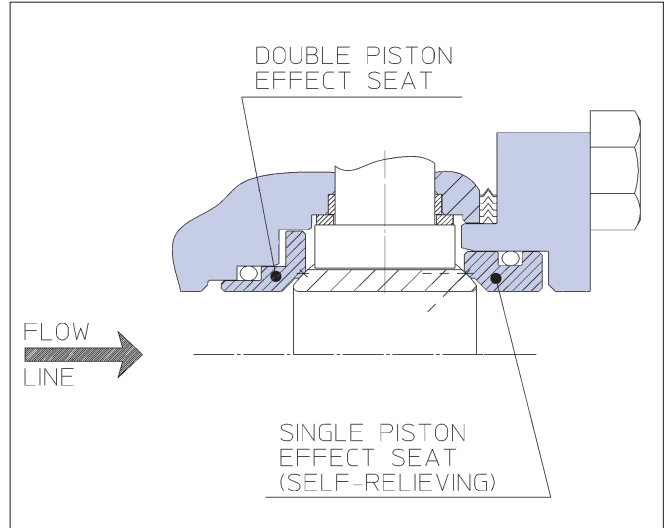

SINGLE PISTON/DOUBLE PISTON EFFECT

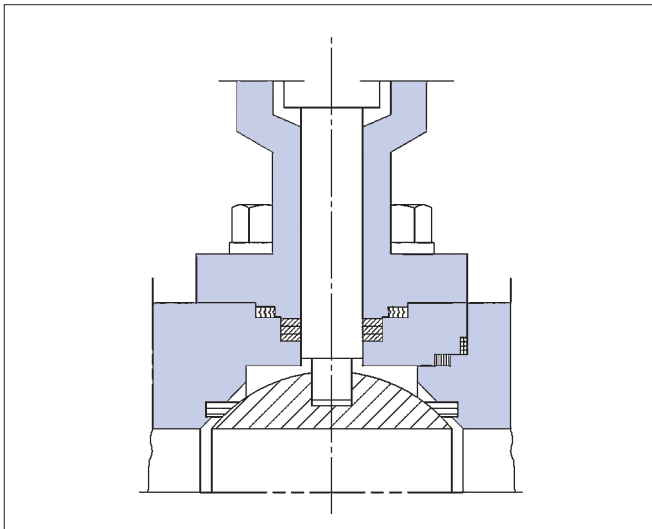

BOLDED EXTENSION - DETAIL

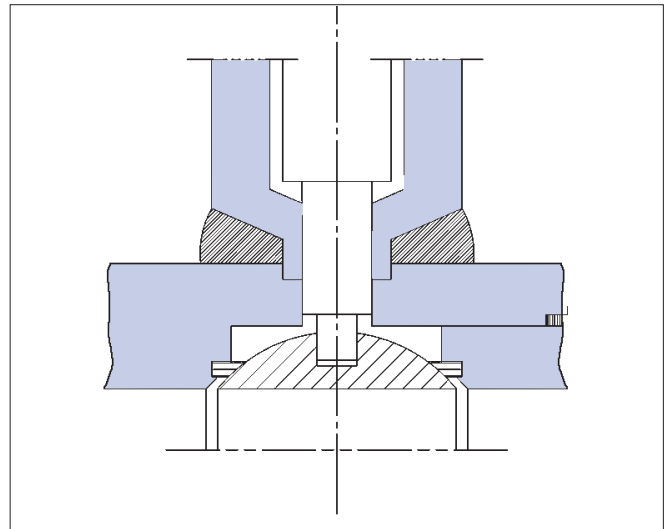

WELDED EXTENSION - DETAIL





TEST BENCH NO 1 - UP TO 2"

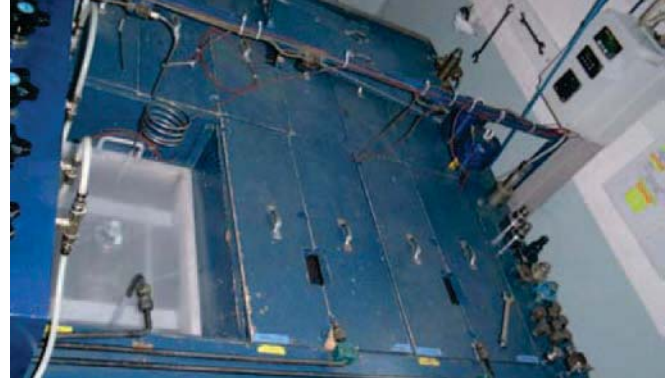

TEST BENCH NO 1 - 6 UNITS

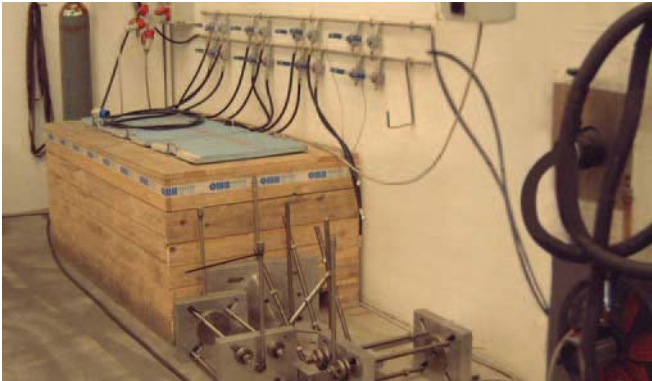

TEST BENCH NO 2 - UP TO 3"



TEST BENCH NO 3 - UP TO 6"



TEST BENCH NO 3 - UP TO 6"

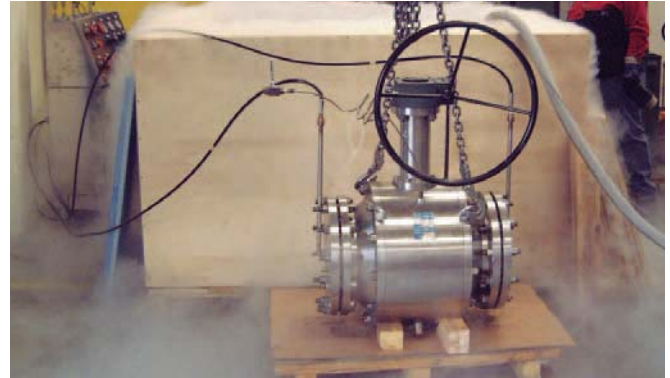

12" # 300 DURING TEST



TEST BENCH NO 5 - UP TO 30"



24" # 900 DURING TEST

TRUNNION TOP ENTRY

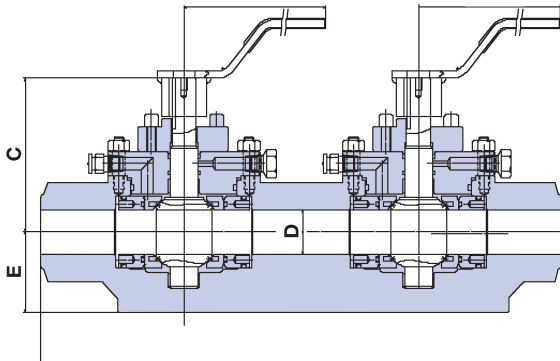

TRUNNION SIDE ENTRY

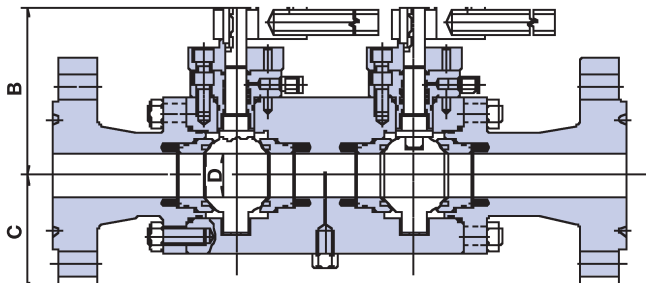

FLOATING END ENTRY

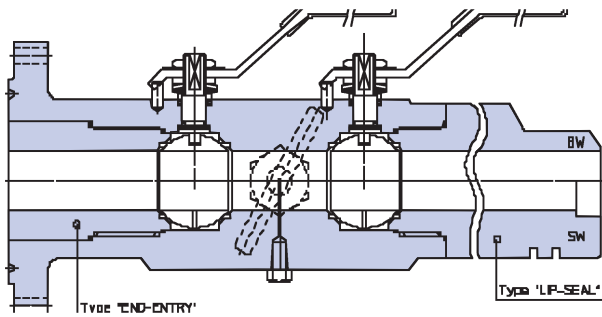

FLOATING SPLIT BODY

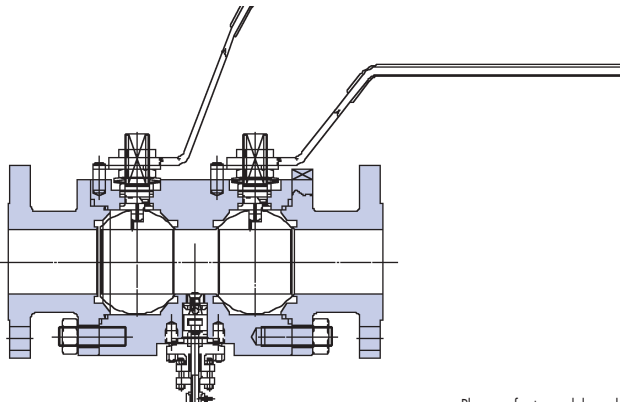

Please refer to modular valves catalogue for further information

The Cv's a valve property and id defined as follows: "The Flow Coefficient Cv states the flow capacity of a valve in U.S. gallons per minute of water at standard temperature of 60°F (15,6°C) that will flow through the valve with a pressure loss of one pound per square inch at a specific opening position". For the metric sistem the analog value is Kv where measure unit Bar, Kg and metres. The Cv show the quality and accuracy of a valve in terms of pressure loss, the highest values of Cv indicate the highest quality of a valve.

API 6A			
CLASSES			
Bore (inch)	3000	5000	10000
1 13/16	270	270	230
2 1/16	350	350	300
3 1/8	1000	940	890
4 1/16	1750	1700	1600
5 1/8	2900	2700	2450
7 1/16	5930	5400	5220

API 6D						
CLASSES						
Bore (inch)	150	300	600	900	1500	2500
2	420	420	400	330	330	250
2 1/2	690	690	610	520	510	320
3x2	200	200	200	190	180	200
3	1200	1050	1000	910	820	500
4x3	600	600	600	590	550	560
4	2200	2100	1850	1800	1700	1100
6x4	800	800	790	790	780	745
6	5150	2100	4600	4380	3800	2500
8x6	2150	2150	2150	2150	2150	2150
8	9500	9400	9000	8500	7400	5300
10x8	4300	4200	4300	4450	4450	4100
10	15000	15000	14700	14500	11500	8300
12x10	7550	7550	7550	8000	9000	7550
14x10	6000	6000	6000	6100	6100	-
12	23000	23000	22500	21100	18000	13000
14x12	14000	14000	14000	12800	13000	-
16x12	9100	9100	9100	8900	8900	-
14	28000	28000	28000	25000	21000	-
16x14	15000	15000	15000	14200	14100	-
16	37200	37200	37200	34500	27500	-
18x16	21000	21000	21000	19200	19000	-
20x16	15300	15300	15300	13800	12000	-
18	49000	49000	49000	45000	37000	-
20x18	28400	28400	28400	25000	25000	-
20	59000	59000	59000	55200	47800	-
24x20	28200	28200	28000	25100	20600	-
22	68200	68200	68200	62000	54000	-
24	92000	92000	92000	83800	70000	-
30x24	36000	36000	36000	32900	-	-
26	111000	110000	110000	98500	-	-
28	121000	121000	121000	113000	-	-
30	145000	144000	144000	130000	-	-
36x30	64000	64000	64000	61500	-	-
32	170000	170000	170000	151000	-	-
36x32	87000	87000	87000	69500	-	-
36	210000	210000	210000	198200	-	-
40	267500	267500	267500	-	-	-
42x36	96700	96700	96000	-	-	-
42	280000	280000	280000	-	-	-
48	384000	384000	384000	-	-	-
56x42	89000	89000	89000	-	-	-
56	521000	521000	521000	-	-	-

FLOW-RATE

$$Q = C_v \sqrt{\frac{\Delta p}{S}}$$

PRESSURE DROP

$$\Delta p = S \left(\frac{Q}{C_v} \right)^2$$

For liquids other than water:

Δp = Pressure drop (p.s.i.).

Q = Liquid flow in gallons per minute (GPM).

S = Specific gravity of liquid relative toater (60°F).

C_v = Valves flow coefficient.

CONVERSION TABLE TO METRI Kv

Flow Coefficient	Cv	Kv
Cv	1	0.865
Kv	1.156	1

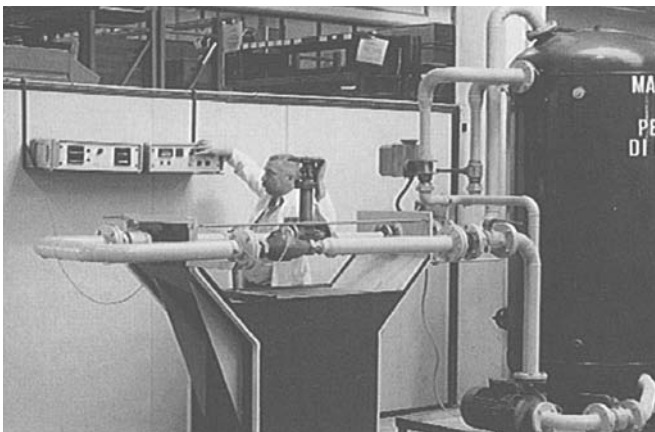

ALL VALVES ARE IN STRICT ACCORDANCE WITH THE FOLLOWING STANDARDS

API 598	- Valve inspection and Test	MSS SP61	- Hydrostatic Testing of Steel Valves
API 607	- Fire Safe Test Soft Seated	MSS SP82	- Valves Pressure Testing Methods
API 6FA	- Specifications for Fire Test of Valves	BS 5351	- Specific for Ball Valve Petroleum, Petrochemical and Allied industries
API B 6D	- Specifications for Pipeline Valves	BS 6364	- Valves for Cryogenic Service
ANSI B 16.5	- Steel Pipe Flanges and Fittings	BS 6755	- Testing of valves
ANSI B 16.10	- Face-to-Face and End-to-End Dimension of ferrous Valves	NACE Standard	- Material Requirement - Sulfide Stress Cracking Resistant
ANSI B 16.11	- Forged Steel Fittings, Socket-Welding and Threaded	MR 01.75	- End to End Dimensions of Ferrous Valves
ANSI B 16.34	- Steel Valves, Flanged and Buttwelded Ends		
MSS SP	- Standard marking System for Valves, Fittings, Flanges and Union		

ASME CLASS	RATING			BODY TEST			.P. SEAT TEST			AIR SEAT TEST		
	psi	bar	Kg/cm ²	psi	bar	Kg/cm ²	psi	bar	Kg/cm ²	psi	bar	Kg/cm ²
150	275	19	19.3	413	28.5	29	303	20.9	21	100	6	7
300	720	50	51	1080	75	77	792	55	56	100	6	7
600	1440	99	101	2160	148.5	152	1584	108.9	111	100	6	7
900	2160	149	152	3240	223.5	228	2376	163.9	167	100	6	7
1500	3600	248	253	5400	372	380	3960	272.8	278	100	6	7
2500	5988	413	421	8982	619.5	632	6587	454.3	463	100	6	7
API 3000	3000	207	210	4500	310.5	315	3300	227.7	231	100	6	7
API 5000	5000	345	352	7500	517.5	528	5500	379.5	387	100	6	7
API 10000	10000	690	703	15000	1035	1055	11000	759	773	100	6	7

SEAT-INSERT (PRESSURE TEMPERATURE RATING)

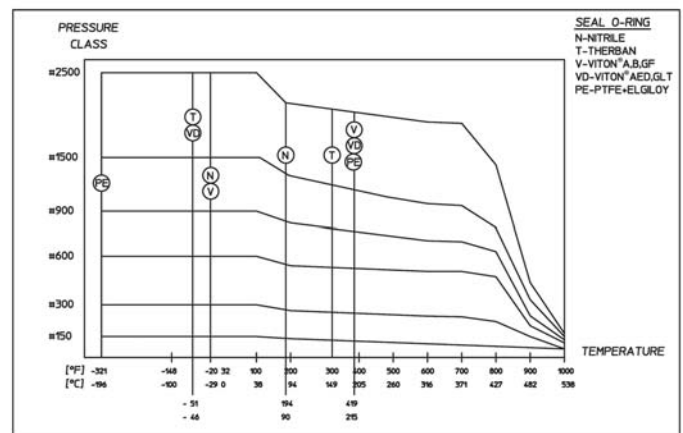
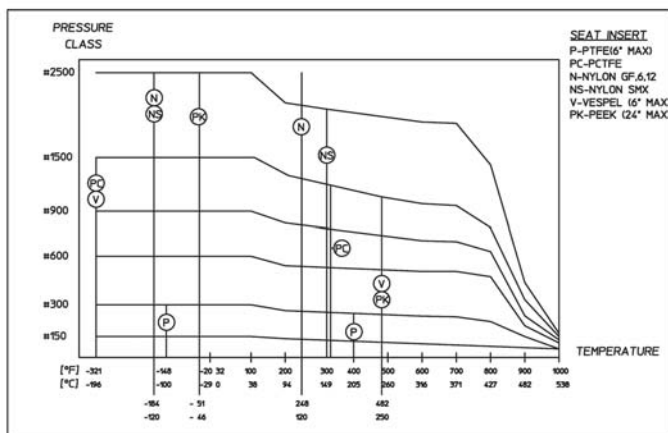

Viton® is a registered trademark of the Dupont Dow Elastomers company



36" CLASS 300 TOP ENTRY FORGED

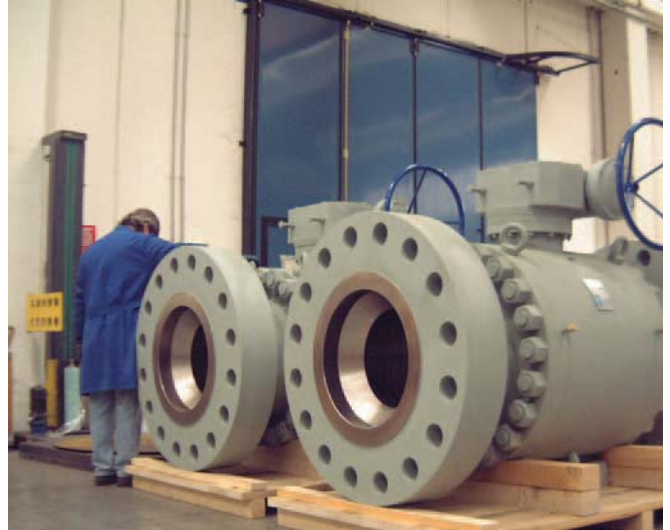

24" CLASS 1500



36" CLASS 150 SIDE



24" CLASS 900



GROUP



16" CLASS 600 TOP ENTRY CAST

PRODUCT INFORMATION REQUEST Request to send the following printed catalogs incopies:

FromCompany

AddressCity

Zip CodeCountry

To: **OMB Valves s.p.a. - Fluicon Division**
 Fax: **+39 035 942 638**



Catalogs can be downloaded at www.ombvalves.com



OMB Valves s.p.a.
Valves Specialist

HEADQUARTERS

Via Europa, 7
24069 Cenate Sotto (Bg) - Italy
Phone +39 035 425 67 11
Fax +39 035 942 638

www.ombvalves.com
www.fluicon.com

Worldwide Network
of Agents and Distributors

WORLDWIDE SUBSIDIARIES

OMB Americas inc.
MONTREAL - CANADA
Phone +1 514 457 08 13
Fax +1 514 457 08 14

OMB Valves Asia Pte. td.
WOODLAND - SINGAPORE
Phone +65 685 221 10
Fax +65 685 214 10

IVM OMB Saudi
Al-Khobar - SAUDI ARABIA
Phone +966 3 889 33 34
Fax +966 3 889 33 32

OMB Valves Spa
Rep. Office SOUTH EAST ASIA & PACIFIC (MALAYSIA)
Phone +60 3 7728 8077
Fax +60 3 7728 6066



Local Agent: >>