

Offshore Valves



Valve Specialists™



Offshore



C-OV1.1

30 YEARS OF INNOVATION

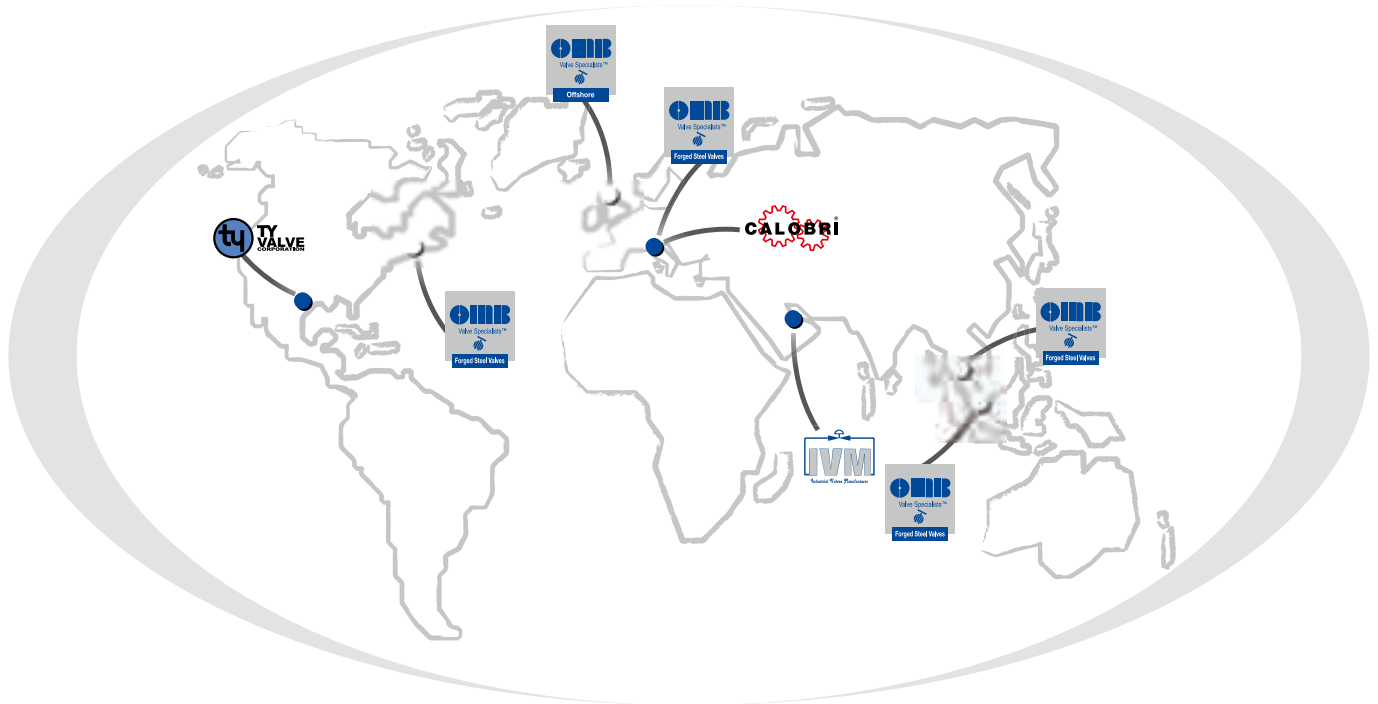

OMB Group a family owned and managed business founded by Mr Roberto Brevi in 1973. The group specialise in forged steel valves from small diameter gate valves to large diameter Trunnion mounted ball valves. The company now operates 5 plants in 3 countries and is established worldwide with a network of agents, distributors and OMB offices.

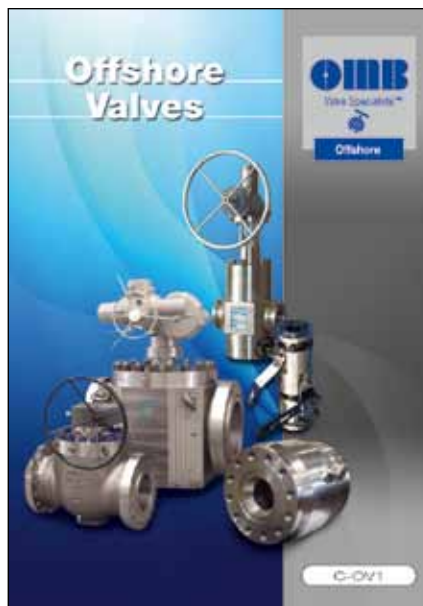

NEW catalog

Welcome to our first catalogue dedicated to offshore valves, this issue includes API 6A & 6D versions of our Through conduit Gate Valves (TCGV), Expanding Gate Valves, Trunnion Ball Valve, Swing Check Valve and DBB modular valves.

The content of this catalog is copyrighted by OMB Valves S.p.A. (c) 2009 Nothing included in this catalog can be reproduced in any form without obtaining prior written consent by OMB Valves S.p.A. All photos and images published are copyrighted: the use of images, even if digitally modified to take away the OMB logo will be prosecuted to the maximum extend of the law.



THE GROUP



At OMB we have developed a comprehensive range of engineered valves products installed globally across a wide range of industries:

- Offshore
- Subsea
- Refining
- Petrochemical
- Chemical
- Desalination

In these past 30 years millions of valves have been supplied to major oil and gas companies worldwide and the OMB name has become synonymous with absolute reliability, superior quality and competitive pricing.

In the early 80's we were the first to introduce robotics in the manufacturing process along with specialized equipment designed to reduce machining time and increase the quality of components.

Today we are more than ever committed to innovation and continuous improvement: we remain focused in expanding our capacity at home, opening new plants near the end users and extending our distribution network.

We invite you to visit our plants where you will see an innovative experienced team working with state of the art equipment to provide the best valve money can buy.

This is our promise !

Roberto, Simone and Fabio Brevi

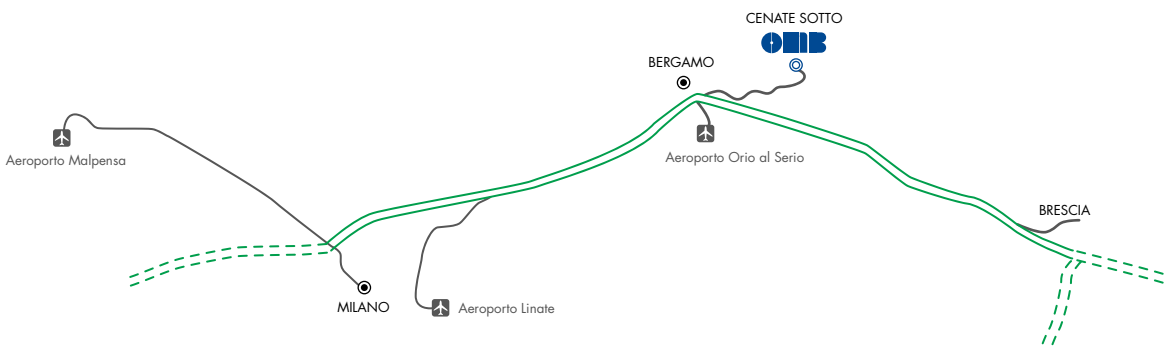

The OMB quality system is certified in accordance to ISO9001:2000 with our comprehensive quality programmes covering the full scope of our activities and has been certified since 1990. OMB products are certified to meet the European Union Pressure Equipment Directive P.E.D. (CE mark) since its introduction in 1994, along with accreditation to meet ATEX requirements. OMB has been accepted as an approved supplier by many of the worlds major energy companies: a complete list of references, inclusive of projects supplied and product details is available on our web site.



ISO 9001



PED



Gost-R



ISO 15848



ATEX

MATERIAL SOURCES AND TRACEABILITY

OMB use forgings made in Italy for all our products: we have an extensive investment in dyes covering all size and pressure classes in every material from carbon steels to the most exotic alloys. All our suppliers are ISO9000 certified.



Our valves are supplied with the forging plant issued BS EN 10204.3.1 certificate as a minimum. We maintain our online database with all the certificates issued, searchable via our web site.

MATERIAL & VALVE TESTING FACILITIES

OMB conduct non-destructive examination by ultrasonics, magnetic particle and liquid penetrant at our site along with, chemical analysis by computer controlled direct reading emission spectrometer and ferrite content analyzer equipment are available.

All valves are hydraulically tested, seat leakage tested and functionally tested. In addition packing emission testing in accordance to the latest ISO requirement, helium gas, cryogenic, vacuum and other functional testing can be arrange in our laboratories.



API 6A – 0778



API 6D – 0289

OMB Valves has an extensive engineering department dedicated exclusively to product design, utilizing the latest design tools and software with 3D and Finite Element Analysis (FEA & TFEA) capabilities. Our mix of young innovative engineers coupled with our very experienced time served engineers provide the perfect combination of professional engineering to design the best valves for your processes.

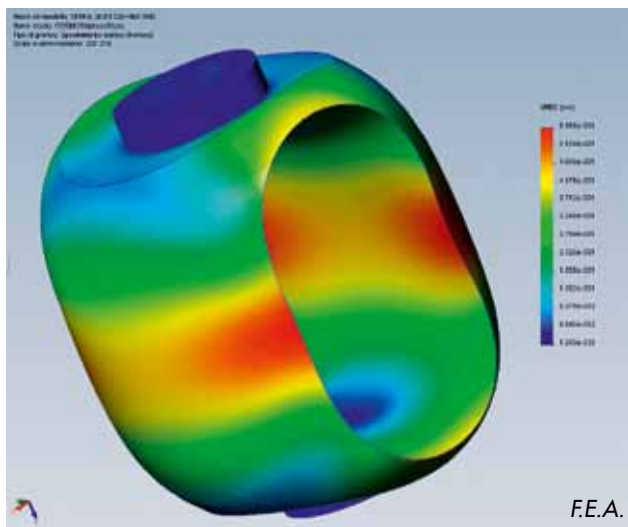

DESIGN & MANUFACTURING STANDARDS

EN ISO 9001:2000	Quality Management System	ISO 5208	Industrial Valve Pressure Testing
ISO 10423 (API 6A)	Drilling and Production Equipment	BS EN 12266-1/2	Testing Of Valves
ISO 14313 (API 6D)	Pipeline transportation systems-pipeline valves	BS EN ISO 4406	Hydraulic Fluid Cleanliness
EU P.E.D.	Pressure Equipment Directive 97/23/EC	BS EN 10204	Metallic Products Inspection Documents
ASME B16.34	Valves-Flanged, Threaded and Welding end	BS EN ISO 10497	Fire Testing
ASME B16.5	Pipe Flanges and Flanged Fittings	API 14D	Sand slurry annex i in API 6A
ASME B16.10	Face to Face Dimensions	NACE MR.01.75	Sulfide Stress Cracking resilient metallic materials
ASME B16.25	Butt weld ends		
ASME II, V, VIII, X	Boiler and Pressure vessel Code		



OMB test 100% of valves thereby guaranteeing our customer fully tested valves to meet their demanding services. Where gas testing is a customer requirement all body gas tests are preceded with a hydro safety test.

For API 6A valve testing will be conducted in accordance with PSL level 3 and 4.

For API 6D valve testing will be conducted in accordance with ISO 5208.

HYDRAULIC TEST



Dimensional Inspection



"Valves tested at independent fire test facility Scotland".

CLASS	RATING			BODY TEST			P. SEAT TEST			AIR SEAT TEST		
	psi	bar	Kg/cm ²	psi	bar	Kg/cm ²	psi	bar	Kg/cm ²	psi	bar	Kg/cm ²
ASME 150	275	19	19.3	413	28.5	29	303	20.9	21	100	6	7
ASME 300	720	50	51	1080	25	77	792	55	56	100	6	7
ASME 600	1440	99	101	2160	148.5	152	1584	108.9	111	100	6	7
ASME 900	2160	149	152	3240	223.5	228	2376	163.9	167	100	6	7
ASME 1500	3600	248	253	5400	372	380	3960	272.8	278	100	6	7
ASME 2500	5988	413	491	8982	619.5	632	6587	454.3	463	100	6	7
API 3000	3000	207	210	4500	310.5	315	3300	227.7	231	100	6	7
API 5000	5000	345	352	7500	517.5	528	5500	379.5	387	100	6	7
API 10000	10000	690	703	15000	103.5	1055	11000	759	773	100	6	7

VALVES



VALVES MOUNTED ON SKID



15000 psi TEST EQUIPMENT

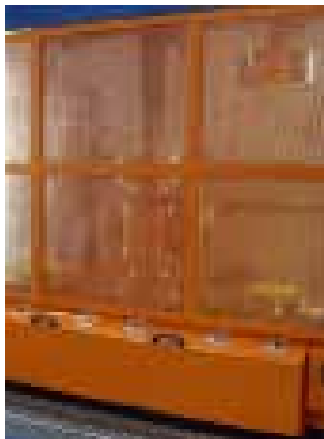
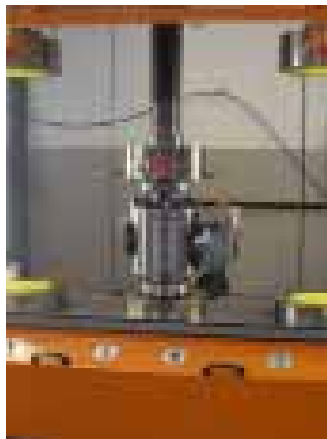

Gate Valves



Ball Valves



Modular Valves



Check Valves

All major isolation valves are manufactured by OMB Valves for your oil & gas processing plant, this is a significant advantage for our customers to have the ability to procure all critical isolation valves from one reliable manufacturer, from the highly critical ESDV's to the latest compact designs for Double Block & Bleed's (DBB), OMB Offshore provide them all.



OMB Trunnion mounted ball valves are manufactured to API 6D and 6A specifications. The construction is side entry three piece full or reduced bore. Lever, gear or actuated options are available in standard and compact designs.

Full Bore and Reduced Bore options are available, full bore valves are suitable for the passage of all types of pipeline

scraper and inspection pigs without causing damage to either the valve or the pig. All valves are designed with anti blow out stem to prevent stem ejection by internal pressure.

Body cavity over pressure is prevented by self relieving seats, For Double Block and or emergency Shut down Valves (ESDV/SSDV) Double Piston Effect Seats will be provided.

CONSTRUCTION

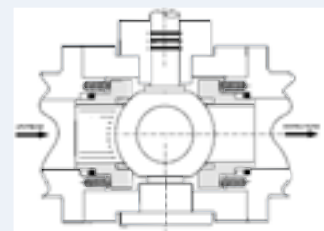

KEY FEATURES ARE:

- ✓ FULL BORE, PIGGABLE
- ✓ BI DIRECTIONAL SEALING.
- ✓ DOUBLE BLOCK CAPABILITIES.
- ✓ BUBBLE TIGHT SEALING.
- ✓ METAL TO METAL SEALING



CLASS DIAMETER	CLASS 150 RB - FB	CLASS 300 RB - FB	CLASS 600 RB - FB	CLASS 900 RB - FB	CLASS 1500 RB - FB	CLASS 2500 RB - FB
1/2"						
3/4"						
1"						
1 1/2"						
2"	●	●	●	●	●	●
3"	●	●	●	●	●	●
4"	●	●	●	●	●	●
6"	●	●	●	●	●	●
8"	●	●	●	●	●	●
10"	●	●	●	●	●	●
12"	●	●	●	●	●	●
14"	●	●	●	●	●	●
16"	●	●	●	●	●	●
18"	●	●	●	●	●	●
20"	●	●	●	●	●	●
22"	●	●	●	●	●	
24"	●	●	●	●	●	
26"	●	●	●	●		
28"	●	●	●	●		
30"	●	●	●	●		
32"	●	●	●	●		
34"	●	●	●	●		
36"	●	●	●	●		
40"	●	●	●			
42"	●	●	●			
48"	●	●	●			
56"-60"	●	●	●			

CLASS DIAMETER	CLASS 3000 RB - FB	CLASS 5000 RB - FB	CLASS 10.000 RB - FB
1" 13/16	●	●	●
2" 9/16	●	●	●
3" 1/8	●	●	●
4" 1/16	●	●	●
7" 1/16	●	●	●
9"	●	●	●
11"	●	●	●

Applicable Standards

API 6D LICIENCE No 6D-0286

API 6A LICIENCE No 6A-0778

API Spec. Q1

API 6D (EN ISO 14313)
Pipeline Transportation Systems-Pipeline Valves.

API 598 (Inspection Testing)

API 14D Sand Slurry (Annex I API 6A)

ASME B16.34

(Wales-Flanged, Threaded and Welding end)

ASME B16.5 (Pipe Flanges and Flanged Fittings)

ASME B16.10 (Face to Face Dimensions)

ASME B16.25 (Butt weld ends)

ASME

(Boiler and Pressure vessel Code II, V, VIII, X)

ASME B31.8

Gas transmission and Distribution piping systems.

ASME B31.4

Liquid Petroleum transmission piping systems.

BS EN ISO 10497 - Fire Testing.

BS EN 12266 - 1/2. (Testing Of Valves)

BS EN ISO 4406 (Hydraulic Fluid Cleanliness)

BS EN 10204 (Metallic Products Inspection Documents)

EU Pressure Equipment Directive.

EN ISO 9001:2008

ISO 5208 (industrial valves pressure testing)

NACE MR0175/ISO 15156

(Sulphide Stress Cracking Resistant Materials for offshore applications)

NORSOK L-001-Piping and Valves.

NORSOK M-630-Material Data Sheets for Piping.

NORSOK M-650-Qualification of Manufacturers of special materials.

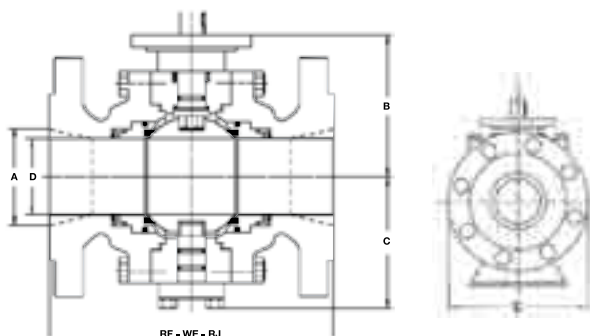

ASME CLASS 150 FULL BORE

SIZE		SIDE ENTRY					
		D	RF	WE	B	C	E
2	in.	2.00	7.00	8.50	5.51	3.54	5.90
50	mm	51	178	216	140	90	150
3	in.	3.00	8.00	11.13	7.48	4.13	7.48
80	mm	76	203	283	190	105	190
4	in.	4.00	9.00	12.00	9.72	5.55	9.00
100	mm	102	229	305	247	141	230
6	in.	6.00	15.50	18.00	11.61	6.88	12.20
150	mm	152	394	457	295	175	310
8	in.	8.00	18.00	20.50	12.99	8.26	15.35
200	mm	203	457	521	330	210	390
10	in.	10.00	21.00	22.00	15.74	9.84	18.11
250	mm	254	533	559	400	250	460
12	in.	12.00	24.00	25.00	18.11	12.20	21.45
300	mm	305	610	635	460	310	545
14	in.	14.00	27.00	30.00	18.89	13.38	24.00
350	mm	356	686	762	480	340	610
16	in.	16.00	30.00	33.00	21.25	15.15	26.37
400	mm	406	762	838	540	385	670
18	in.	18.00	34.00	36.00	22.83	16.85	24.80
450	mm	457	864	914	580	428	630
20	in.	20.00	36.00	39.00	23.00	21.45	33.43
500	mm	508	914	991	584	545	849
22	in.	22.00	40.00	43.00	24.00	23.00	36.81
550	mm	559	991	1092	610	584	935
24	in.	24.00	42.00	45.00	24.10	25.87	39.57
600	mm	610	1067	1143	612	655	1005
26	in.	26.00	45.00	49.00	24.69	22.20	41.73
650	mm	660	1143	1245	627	564	1060
28	in.	28.00	49.00	53.00	25.35	25.91	44.88
700	mm	711	1245	1346	644	658	1140
30	in.	30.00	51.00	55.00	27.20	27.70	47.24
750	mm	762	1295	1397	691	705	1200
32	in.	32.00	54.00	60.00	29.21	29.37	51.18
800	mm	813	1372	1524	742	746	1300
34	in.	34.00	58.00	64.00	29.88	30.51	53.94
850	mm	864	1473	1626	759	775	1370
36	in.	36.00	60.00	68.00	31.97	31.77	56.30
900	mm	914	1524	1727	812	807	1430
40	in.	40.00	69.00	77.00	35.43	35.35	63.00
1000	mm	1016	1753	1956	900	898	1600
42	in.	42.00	72.00	82.00	37.13	37.00	64.96
1050	mm	1067	1855	2083	943	940	1656
48	in.	48.00	80.00	94.00	43.19	41.73	75.59
1200	mm	1219	2134	2388	1097	1060	1920
56	in.	53.54	98.00	98.00	52.00	50.00	89.00
1400	mm	1360	2490	2490	13.21	1270	2260

ASME CLASS 150 REDUCED BORE

SIZE		SIDE ENTRY						
		A	D	RF	WE	B	C	E
2 x 1/2	in.	2.00	1.50	7.00	8.50	4.00	3.00	5.90
50 x 40	mm	51	38	178	216	101	76	150
3 x 2	in.	3.00	2.00	8.00	11.13	5.51	3.54	7.48
80 x 50	mm	76	51	203	283	140	90	190
4 x 3	in.	4.00	3.00	9.00	12.00	7.48	4.13	9.00
100 x 80	mm	102	76	229	305	190	105	230
6 x 4	in.	6.00	4.00	15.50	18.00	11.02	6.53	12.20
150 x 100	mm	152	102	394	457	280	166	310
8 x 6	in.	8.00	6.00	18.00	20.50	11.61	6.88	15.35
200 x 150	mm	203	152	457	521	295	175	395
10 x 8	in.	10.00	8.00	21.00	22.00	12.99	8.26	15.98
250 x 200	mm	254	203	533	559	330	210	406
12 x 10	in.	12.00	10.00	24.00	25.00	15.74	9.84	19.02
300 x 250	mm	305	254	610	635	400	250	483
14 x 10	in.	14.00	10.00	27.00	30.00	18.11	12.30	21.06
350 x 250	mm	356	254	686	762	460	310	535
14 x 12	in.	14.00	12.00	27.00	30.00	18.11	12.20	21.06
350 x 300	mm	356	305	686	762	460	310	535
16 x 12	in.	16.00	12.00	30.00	33.00	18.89	13.38	23.43
400 x 300	mm	406	305	762	838	480	340	595
16 x 14	in.	16.00	14.00	30.00	33.00	18.89	13.38	23.43
400 x 350	mm	406	356	762	838	480	340	595
18 x 16	in.	18.00	16.00	34.00	36.00	21.25	15.15	24.80
450 x 400	mm	457	406	864	914	540	385	630
20 x 16	in.	20.00	16.00	36.00	39.00	22.83	16.85	27.56
500 x 400	mm	508	406	914	991	580	428	700
20 x 18	in.	20.00	18.00	36.00	39.00	22.83	16.85	27.56
500 x 450	mm	508	457	914	991	580	428	700
24 x 20	in.	24.00	20.00	42.00	45.00	23.00	18.00	32.28
600 x 500	mm	610	508	1067	1143	584	457	820
28 x 24	in.	28.00	24.00	49.00	53.00	24.50	19.49	37.40
700 x 600	mm	711	610	1245	1346	622	495	950
30 x 24	in.	30.00	24.00	51.00	55.00	25.15	20.28	38.78
750 x 600	mm	762	610	1295	1397	638	515	985
36 x 30	in.	36.00	30.00	60.00	68.00	27.17	27.56	46.06
900 x 750	mm	914	762	1524	1727	690	700	1170

The valve details on this page are the standard production range only, for other size valves or end configurations please consult the factory.
 Note OMB reserves the right to make modifications or changes to its production, without prior notice and take no responsibility for any errors in this publication.

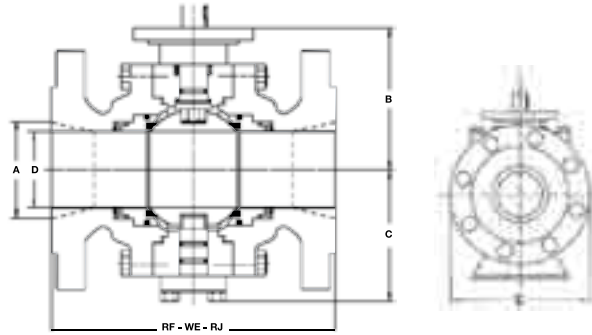

ASME CLASS 300 FULL BORE

SIZE		SIDE ENTRY					
		D	RF	WE	B	C	E
2	in.	2.00	8.50	8.50	7.87	4.72	6.50
50	mm	51	216	216	200	120	165
3	in.	3.00	11.10	11.10	9.44	5.11	8.50
80	mm	76	283	283	240	130	218
4	in.	4.00	12.00	12.00	9.72	5.55	10.00
100	mm	102	305	305	247	141	254
6	in.	6.00	15.90	18.00	11.61	6.88	12.20
150	mm	152	457	457	295	175	310
8	in.	8.00	19.80	20.50	12.99	8.26	15.40
200	mm	203	502	521	330	210	390
10	in.	10.00	22.40	22.00	16.53	10.62	18.50
250	mm	254	568	559	420	270	470
12	in.	12.00	25.50	25.00	18.30	12.79	21.30
300	mm	305	648	635	465	325	545
14	in.	14.00	30.00	30.00	21.45	16.92	24.80
350	mm	356	762	762	545	430	630
16	in.	16.00	33.00	33.00	23.62	18.50	27.20
400	mm	406	838	838	600	470	690
18	in.	18.00	36.00	36.00	23.10	20.07	30.30
450	mm	457	914	914	586	510	770
20	in.	20.00	39.00	39.00	23.90	19.68	33.50
500	mm	508	991	991	607	500	850
22	in.	22.00	43.00	43.00	24.10	21.00	37.00
550	mm	559	1092	1092	612	533	940
24	in.	24.00	45.00	45.00	24.50	23.62	39.70
600	mm	610	1143	1143	622	600	1010
26	in.	26.00	49.00	49.00	24.80	22.80	42.50
650	mm	660	1245	1245	630	580	1080
28	in.	28.00	53.00	53.00	25.20	26.60	45.30
700	mm	711	1346	1346	640	675	1150
30	in.	30.00	55.00	55.00	27.60	28.70	48.40
750	mm	762	1397	1397	700	730	1230
32	in.	32.00	60.00	60.00	29.30	29.90	52.00
800	mm	813	1524	1524	745	760	1320
34	in.	34.00	64.00	64.00	29.90	31.50	54.50
850	mm	864	1626	1626	760	800	1380
36	in.	36.00	68.00	68.00	31.70	32.5	56.9
900	mm	914	1727	1727	805	825	1445
40	in.	40.00	77.00	77.00	35.40	36.2	64.10
1000	mm	1016	1956	1956	900	920	1630
42	in.	42.00	82.00	82.00	38.10	38.40	66.90
1050	mm	1067	2083	2083	968	980	1700
48	in.	48.00	85.40	85.40	43.30	45.60	74.80
1200	mm	1219	2170	2170	1100	1160	1960
56	in.	53.54	108.00	108.00	50.00	50.00	89.00
1400	mm	1360	2743	2743	1270	1270	2260

ASME CLASS 300 REDUCED BORE

SIZE		SIDE ENTRY						
		A	D	RF	WE	B	C	E
2 x 1/2	in.	2.00	1.50	8.50	8.50	6.88	3.14	6.50
50 x 40	mm	51	38	216	216	175	80	165
3 x 2	in.	3.00	2.00	11.10	11.10	7.87	4.72	8.50
80 x 50	mm	76	51	283	283	200	120	218
4 x 3	in.	4.00	3.00	12.00	12.00	9.44	5.11	10.00
100 x 80	mm	102	76	305	305	240	130	254
6 x 4	in.	6.00	4.00	15.90	18.00	11.02	5.90	12.20
150 x 100	mm	152	102	457	457	280	150	310
8 x 6	in.	8.00	6.00	19.80	20.50	11.61	6.88	15.40
200 x 150	mm	203	152	502	521	295	175	390
10 x 8	in.	10.00	8.00	22.40	22.00	12.99	8.26	18.50
250 x 200	mm	254	203	568	559	330	210	470
12 x 10	in.	12.00	10.00	25.50	25.00	16.53	10.62	21.30
300 x 250	mm	305	254	648	635	420	270	520
14 x 10	in.	14.00	10.00	30.00	30.00	18.30	12.79	23.00
350 x 250	mm	356	254	762	762	465	325	585
14 x 12	in.	14.00	12.00	30.00	30.00	18.30	12.79	23.00
350 x 250	mm	356	305	762	762	465	325	585
16 x 12	in.	16.00	12.00	33.00	33.00	21.45	16.92	25.60
400 x 300	mm	406	305	838	838	545	430	650
16 x 14	in.	16.00	14.00	33.00	33.00	21.45	16.92	25.60
400 x 350	mm	406	356	838	838	545	430	650
18 x 16	in.	18.00	16.00	36.00	36.00	23.62	18.50	28.00
450 x 400	mm	457	406	914	914	600	470	710
20 x 16	in.	20.00	16.00	39.00	39.00	24.40	20.07	30.70
500 x 400	mm	508	406	991	991	620	510	780
20 x 18	in.	20.00	18.00	39.00	39.00	24.40	20.07	30.40
500 x 450	mm	508	457	991	991	620	510	780
24 x 20	in.	24.00	20.00	45.00	45.00	25.10	19.68	36.00
600 x 500	mm	610	508	1143	1143	637	500	915
30 x 24	in.	30.00	24.00	55.00	55.00	25.80	21.20	42.90
750 x 600	mm	762	610	1397	1397	655	540	1090
36 x 30	in.	36.00	30.00	68.00	68.00	27.60	28.70	50.00
900 x 750	mm	914	762	1727	1727	700	730	1270

The valve details on this page are the standard production range only, for other size valves or end configurations please consult the factory.
 Note OMB reserves the right to make modifications or changes to its production, without prior notice and take no responsibility for any errors in this publication.



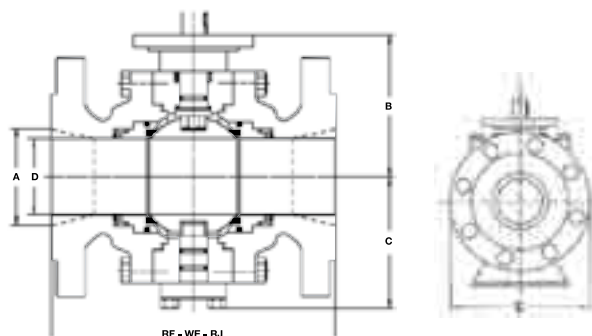

ASME CLASS 600 FULL BORE

SIZE		SIDE ENTRY						
		D	RF	RJ	WE	B	C	E
2	in.	2.00	11.50	11.63	11.50	7.67	4.33	6.50
50	mm	51	292	295	292	195	110	165
3	in.	3.00	14.00	14.13	14.00	9.44	4.33	8.50
80	mm	76	356	359	356	240	110	218
4	in.	4.00	17.00	17.13	17.00	11.02	6.88	10.70
100	mm	102	432	435	432	280	175	273
6	in.	6.00	22.00	22.13	22.00	12.00	7.67	14.10
150	mm	152	559	562	559	305	195	360
8	in.	8.00	26.00	26.13	26.00	15.74	11.02	16.50
200	mm	203	660	664	660	400	280	419
10	in.	10.00	31.00	31.13	31.00	17.12	11.22	20.40
250	mm	254	787	791	787	435	285	520
12	in.	12.00	33.00	33.13	33.00	17.32	12.59	22.60
300	mm	305	838	841	838	440	320	575
14	in.	14.00	35.00	35.13	35.00	19.88	13.38	24.70
350	mm	356	889	892	889	505	340	628
16	in.	16.00	39.00	39.13	39.00	23.22	16.14	27.60
400	mm	406	991	994	991	590	410	700
18	in.	18.00	43.00	43.13	43.00	23.55	17.51	30.50
450	mm	457	1092	1095	1092	589	445	775
20	in.	20.00	47.00	47.25	47.00	23.80	20.07	34.10
500	mm	508	1194	1200	1194	604	510	865
22	in.	22.00	51.00	51.38	51.00	24.00	20.35	37.40
550	mm	559	1295	1305	1295	609	571	950
24	in.	24.00	55.00	55.38	55.00	24.50	25.19	40.50
600	mm	610	1397	1407	1397	622	640	1028
26	in.	26.00	57.00	57.50	57.00	24.80	24.30	40.10
650	mm	660	1448	1461	1448	630	618	1020
28	in.	28.00	61.00	61.50	61.00	26.20	27.20	46.10
700	mm	711	1549	1562	1549	665	692	1172
30	in.	30.00	66.30	66.50	66.30	29.20	31.50	50.80
750	mm	762	1651	1664	1651	741	800	1290
32	in.	32.00	70.00	70.72	70.00	29.80	31.70	52.40
800	mm	813	1778	1794	1778	756	804	1330
34	in.	34.00	76.00	76.52	76.00	30.80	32.20	57.10
850	mm	864	1930	1946	1930	782	817	1450
36	in.	36.00	82.00	82.63	82.00	34.20	37.20	60.90
900	mm	914	2083	2099	2083	869	945	1546
40	in.	40.00	85.40	85.43	85.40	36.10	38.60	64.80
1000	mm	1016	2170	2170	2170	916	980	1645
42	in.	42.00	85.60	85.63	85.60	39.20	43.70	70.80
1050	mm	1067	2175	2175	2175	995	1110	1800
48	in.	48.00	95.90	95.87	95.90	44.60	49.80	81.50
1200	mm	1219	2435	2435	2435	1132	1265	2070
56	in.	53.54	106.70	106.70	106.70	51.00	57.50	94.00
1400	mm	1360	2710	2710	2710	1295	1460	2390

ASME CLASS 600 REDUCED BORE

SIZE		SIDE ENTRY							
		A	D	RF	RJ	WE	B	C	E
2 x 1/2	in.	2.00	1.50	11.50	11.63	11.50	7.48	3.54	6.50
50 x 40	mm	51	38	292	295	292	190	90	165
3 x 2	in.	3.00	2.00	14.00	14.13	14.00	14.01	4.33	8.30
80 x 50	mm	76	51	356	359	356	356	110	210
4 x 3	in.	4.00	3.00	17.00	17.13	17.00	9.44	4.33	14.70
100 x 80	mm	102	76	432	435	432	240	110	373
6 x 4	in.	6.00	4.00	22.00	22.13	22.00	11.02	6.88	14.00
150 x 100	mm	152	102	559	562	559	280	175	356
8 x 6	in.	8.00	6.00	26.00	26.13	26.00	12.00	7.67	16.50
200 x 150	mm	203	152	660	664	660	305	195	419
10 x 8	in.	10.00	8.00	31.00	31.13	31.00	15.74	11.02	20.10
250 x 200	mm	254	203	787	791	787	400	280	510
12 x 10	in.	12.00	10.00	33.00	33.13	33.00	17.12	11.22	22.00
300 x 250	mm	305	254	838	841	838	435	285	560
14 x 10	in.	14.00	10.00	35.00	35.13	35.00	17.32	12.59	23.80
350 x 250	mm	356	254	889	892	889	440	320	605
14 x 12	in.	14.00	12.00	35.00	35.13	35.00	17.32	12.59	23.80
350 x 250	mm	356	305	889	892	889	440	320	605
16 x 12	in.	16.00	12.00	39.00	39.13	39.00	19.88	13.38	27.00
400 x 300	mm	406	305	991	994	991	505	340	685
16 x 14	in.	16.00	14.00	39.00	39.13	39.00	19.88	13.38	24.70
400 x 350	mm	406	356	991	994	991	505	340	628
18 x 16	in.	18.00	16.00	43.00	43.13	43.00	23.22	16.10	29.30
450 x 400	mm	457	406	1092	1095	1092	590	410	745
20 x 16	in.	20.00	16.00	47.00	47.25	47.00	23.80	17.51	32.10
500 x 400	mm	508	406	1194	1200	1194	604	445	815
20 x 18	in.	20.00	18.00	47.00	47.25	47.00	24.00	17.51	32.10
500 x 450	mm	508	457	1194	1200	1194	609	445	815
24 x 20	in.	24.00	20.00	55.00	55.38	55.00	24.50	20.07	37.00
600 x 500	mm	610	508	1397	1407	1397	622	510	940
30 x 24	in.	30.00	24.00	66.30	66.50	66.30	24.80	22.40	44.50
750 x 600	mm	762	610	1651	1664	1651	629	570	1130
36 x 30	in.	36.00	30.00	82.00	82.63	82.00	27.90	29.90	51.80
900 x 750	mm	914	762	2083	2099	2083	708	760	1315

The valve details on this page are the standard production range only, for other size valves or end configurations please consult the factory.
 Note OMB reserves the right to make modifications or changes to its production, without prior notice and take no responsibility for any errors in this publication.



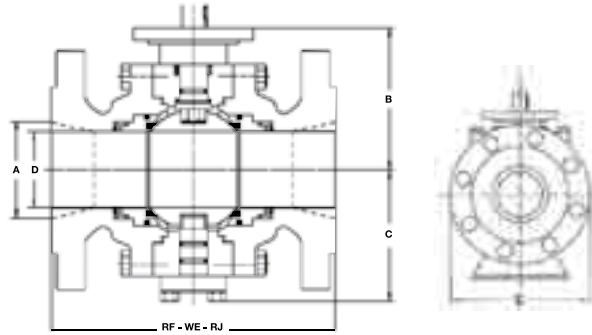

ASME CLASS 900 FULL BORE

		SIDE ENTRY						
SIZE		D	RF	RJ	WE	B	C	E
2	in.	2.00	14.49	14.61	14.49	7.87	4.72	8.50
50	mm	51	368	371	368	200	120	220
3	in.	3.00	15.00	15.12	15.00	9.44	5.11	9.49
80	mm	76	381	384	381	240	130	241
4	in.	4.00	17.99	18.11	17.99	11.02	6.88	11.50
100	mm	102	457	460	457	280	175	290
6	in.	6.00	24.02	24.13	24.02	13.77	8.66	15.00
150	mm	152	610	613	610	350	220	381
8	in.	8.00	29.02	29.13	29.02	15.35	10.23	18.50
200	mm	203	737	740	737	390	260	470
10	in.	10.00	32.99	33.11	32.99	18.89	14.20	21.46
250	mm	254	838	841	838	480	310	545
12	in.	12.00	37.99	38.11	37.99	17.24	16.14	24.02
300	mm	305	965	968	965	438	410	610
14	in.	14.00	40.51	40.87	40.51	21.45	14.56	25.50
350	mm	356	1029	1038	1029	545	370	650
16	in.	16.00	44.49	44.88	44.49	24.59	16.53	27.95
400	mm	406	1130	1140	1130	624	420	710
18	in.	18.00	47.99	48.50	47.99	24.80	24.29	31.50
450	mm	457	1219	1232	1219	630	617	800
20	in.	20.00	52.01	52.48	52.01	25.00	28.54	35.04
500	mm	508	1321	1334	1321	635	725	890
24	in.	24.00	60.98	61.73	60.98	26.00	32.71	41.69
600	mm	610	1549	1568	1549	660	831	1059
28	in.	28.00	69.02	69.88	69.02	26.54	27.80	48.58
700	mm	711	1753	1775	1753	674	706	1234
30	in.	30.00	74.02	74.88	74.02	28.50	30.59	51.18
750	mm	762	1880	1902	1880	725	777	1300
32	in.	32.00	80.00	80.87	80.00	30.87	31.90	53.43
800	mm	813	2032	2054	2032	784	810	1357
34	in.	34.00	85.00	86.14	85.00	31.77	33.54	57.80
850	mm	864	2159	2188	2159	807	852	1468
36	in.	36.00	90.00	91.14	90.00	33.39	35.35	60.31
900	mm	914	2286	2315	2286	848	898	1532

ASME CLASS 900 REDUCED BORE

		SIDE ENTRY							
SIZE		A	D	RF	RJ	WE	B	C	E
2 x 1/2	in.	2.00	1.50	14.49	14.61	14.49	6.10	4.25	8.60
50 x 40	mm	51	38	368	371	368	155	108	220
3 x 2	in.	3.00	2.00	15.00	15.12	15.00	7.87	4.72	9.49
80 x 50	mm	76	51	381	384	381	200	120	241
4 x 3	in.	4.00	3.00	17.99	18.11	17.99	9.44	5.11	11.50
100 x 80	mm	102	76	457	460	457	240	130	290
6 x 4	in.	6.00	4.00	24.02	24.13	24.02	11.02	6.88	14.90
150 x 100	mm	152	102	610	613	610	280	175	381
8 x 6	in.	8.00	6.00	29.02	29.13	29.02	13.77	8.66	18.50
200 x 150	mm	203	152	737	740	737	350	220	470
10 x 8	in.	10.00	8.00	32.99	33.11	32.99	15.35	10.23	21.46
250 x 200	mm	254	203	838	841	838	390	260	545
12 x 10	in.	12.00	10.00	37.99	38.11	37.99	18.89	12.20	24.02
300 x 250	mm	305	254	965	968	965	480	310	610
14 x 10	in.	14.00	10.00	40.51	40.87	40.51	17.24	16.14	25.50
350 x 250	mm	356	254	1029	1038	1029	438	410	650
14 x 12	in.	14.00	12.00	40.51	40.87	40.51	17.24	16.14	27.90
350 x 300	mm	356	305	1029	1038	1029	438	410	710
16 x 12	in.	16.00	12.00	44.49	44.88	44.49	21.45	14.56	29.50
400 x 300	mm	406	305	1130	1140	1130	545	370	750
16 x 14	in.	16.00	14.00	44.49	44.88	44.49	21.45	14.56	31.10
400 x 350	mm	406	356	1130	1140	1130	545	370	790
18 x 16	in.	18.00	16.00	47.99	48.50	47.99	24.59	16.53	31.50
450 x 400	mm	457	406	1219	1232	1219	624	420	800
20 x 16	in.	20.00	16.00	52.01	52.48	52.01	25.00	24.29	31.10
500 x 400	mm	508	406	1321	1334	1321	630	617	790
20 x 18	in.	20.00	18.00	52.01	52.48	52.01	25.57	24.29	35.04
500 x 450	mm	508	457	1321	1334	1321	649	617	890
24 x 20	in.	24.00	20.00	60.98	61.73	60.98	25.70	28.54	40.94
600 x 500	mm	610	508	1549	1568	1549	652	725	1040
30 x 24	in.	30.00	24.00	74.02	74.88	74.02	28.00	24.88	48.43
750 x 600	mm	762	610	1880	1902	1880	711	632	1230
36 x 30	in.	36.00	30.00	90.00	91.14	90.00	31.70	30.87	57.48
900 x 750	mm	914	762	2286	2315	2286	807	784	1460

The valve details on this page are the standard production range only, for other size valves or end configurations please consult the factory.
 Note OMB reserves the right to make modifications or changes to its production, without prior notice and take no responsibility for any errors in this publication.



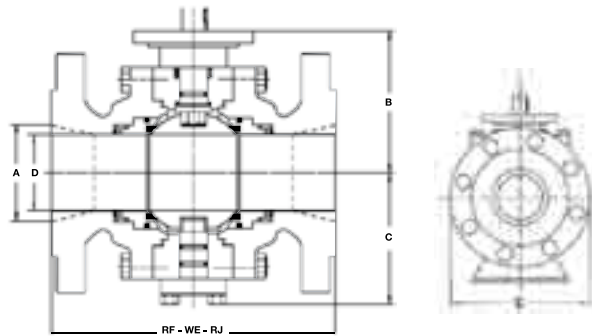

ASME CLASS 1500 FULL BORE

SIZE		SIDE ENTRY						
		D	RF	RJ	WE	B	C	E
2	in.	2.00	14.49	14.61	14.49	8.07	4.72	8.60
50	mm	51	368	371	368	205	120	220
3	in.	3.00	18.50	18.62	18.50	8.26	4.92	10.51
80	mm	76	470	473	470	210	125	267
4	in.	4.00	21.50	21.61	21.50	9.64	6.29	12.20
100	mm	102	546	549	546	245	160	310
6	in.	6.00	27.76	27.99	27.76	13.18	10.03	15.51
150	mm	152	705	711	705	335	255	394
8	in.	8.00	32.76	33.11	32.76	17.20	13.38	19.09
200	mm	203	832	841	832	437	340	485
10	in.	10.00	39.02	39.37	39.02	19.76	15.00	23.03
250	mm	254	991	1000	991	502	381	585
12	in.	12.00	44.49	44.61	44.49	20.98	17.24	27.95
300	mm	305	1130	1146	1130	533	438	710
14	in.	14.00	49.49	50.24	49.49	24.64	19.60	30.12
350	mm	356	1257	1276	1257	626	498	765
16	in.	16.00	54.49	55.35	54.49	28.54	18.11	33.39
400	mm	406	1384	1407	1384	725	460	848
18	in.	18.00	60.51	61.38	60.51	29.00	23.90	38.58
450	mm	457	1537	1559	1537	736	607	980
20	in.	20.00	65.51	66.38	65.51	30.00	25.40	39.96
500	mm	508	1664	1686	1664	762	644	1015
24	in.	24.00	80.43	81.54	80.43	32.00	28.50	50.91
600	mm	610	2043	1972	2043	813	725	1295

ASME CLASS 1500 REDUCED BORE

SIZE		SIDE ENTRY							
		A	D	RF	RJ	WE	B	C	E
2 x 1/2	in.	2.00	1.50	14.49	14.61	14.49	7.48	4.33	8.66
50 x 40	mm	51	38	368	371	368	190	110	220
3 x 2	in.	3.00	2.00	18.50	18.62	18.50	8.07	4.72	10.51
80 x 50	mm	76	51	470	473	470	205	120	267
4 x 3	in.	4.00	3.00	21.50	21.61	21.50	8.26	4.92	12.20
100 x 80	mm	102	76	546	549	546	210	125	310
6 x 4	in.	6.00	4.00	27.76	27.99	27.76	9.64	6.29	15.51
150 x 100	mm	152	102	705	711	705	245	160	394
8 x 6	in.	8.00	6.00	32.76	33.11	32.76	13.18	10.03	19.09
200 x 150	mm	203	152	832	841	832	335	255	485
10 x 8	in.	10.00	8.00	39.02	39.37	39.02	16.14	11.41	23.03
250 x 200	mm	254	203	991	1000	991	410	290	585
12 x 10	in.	12.00	10.00	44.49	44.61	44.49	18.30	13.18	26.57
300 x 250	mm	305	254	1130	1146	1130	465	335	675
14 x 10	in.	14.00	10.00	49.49	50.24	49.49	21.77	17.24	27.95
350 x 250	mm	356	254	1257	1276	1257	553	439	710
14 x 12	in.	14.00	12.00	49.49	50.24	49.49	21.77	17.24	29.92
350 x 300	mm	356	305	1257	1276	1257	553	438	760
16 x 12	in.	16.00	12.00	54.49	55.35	54.49	24.64	19.60	32.48
400 x 300	mm	406	305	1384	1407	1384	626	498	825
16 x 14	in.	16.00	14.00	54.49	55.35	54.49	24.64	19.60	32.48
400 x 350	mm	406	356	1384	1407	1384	626	498	825
18 x 16	in.	18.00	16.00	60.51	61.38	60.51	25.00	20.00	36.22
450 x 400	mm	457	406	1537	1559	1537	630	508	920
20 x 16	in.	20.00	16.00	65.51	66.38	65.51	26.00	20.00	38.97
500 x 400	mm	508	406	1664	1686	1664	660	508	990
20 x 18	in.	20.00	18.00	65.51	66.38	66.51	28.00	23.00	38.97
500 x 450	mm	508	457	1664	1686	1664	711	542	990
24 x 20	in.	24.00	20.00	80.43	81.54	80.43	30.00	25.00	46.06
600 x 500	mm	610	508	2043	1972	2043	762	635	1170

ASME CLASS 2500 FULL BORE

SIZE		SIDE ENTRY						
		D	RF	RJ	WE	B	C	E
2	in.	2.00	17.76	17.87	17.76	8.46	5.11	9.05
50	mm	51	451	454	451	215	130	230
3	in.	3.00	22.76	22.99	22.76	8.66	5.31	11.08
80	mm	76	578	584	578	220	135	300
4	in.	4.00	26.50	26.89	26.50	10.03	6.96	14.02
100	mm	102	673	683	673	255	170	356
6	in.	6.00	35.98	36.50	35.98	16.92	10.43	19.09
150	mm	152	914	927	914	430	265	485
8	in.	8.00	40.24	40.87	40.24	16.92	13.30	24.41
200	mm	203	1022	1038	1022	430	340	620
10	in.	10.00	50.00	50.87	50.00	17.50	16.60	29.33
250	mm	254	1270	1292	1270	444	421	745
12	in.	12.00	55.98	56.89	55.98	18.00	18.90	34.44
300	mm	305	1422	1445	1422	457	480	875

ASME CLASS 2500 REDUCED BORE

SIZE		SIDE ENTRY							
		A	D	RF	RJ	WE	B	C	E
2 x 1/2	in.	2.00	1.50	17.76	17.87	17.76	7.78	4.72	9.25
50 x 40	mm	51	38	451	454	451	200	120	230
3 x 2	in.	3.00	2.00	22.76	22.99	22.76	8.46	5.11	11.01
80 x 50	mm	76	51	578	584	578	215	130	300
4 x 3	in.	4.00	3.00	26.50	26.89	26.50	8.66	5.31	14.02
100 x 80	mm	102	76	673	683	673	220	135	356
6 x 4	in.	6.00	4.00	35.98	36.50	35.98	10.03	6.96	19.09
150 x 100	mm	152	102	914	927	914	255	170	485
8 x 6	in.	8.00	6.00	40.24	40.87	40.24	12.00	9.00	22.05
200 x 150	mm	203	152	1022	1038	1022	348	228	560
10 x 8	in.	10.00	8.00	50.00	50.87	50.00	14.00	13.00	26.57
250 x 200	mm	254	203	1270	1292	1270	355	330	670
12 x 10	in.	12.00	10.00	55.98	56.89	55.98	16.00	18.00	30.70
300 x 250	mm	305	254	1422	1445	1422	406	475	780

The valve details on this page are the standard production range only, for other size valves or end configurations please consult the factory. Note OMB reserves the right to make modifications or changes to its production, without prior notice and take no responsibility for any errors in this publication.



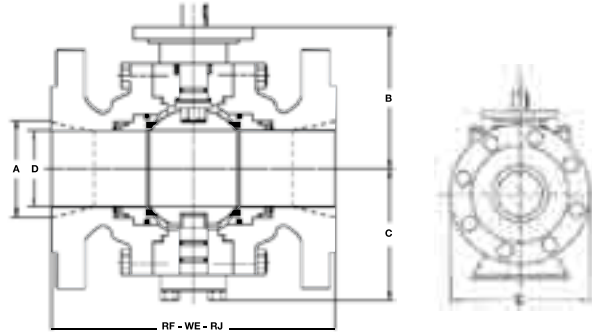

API CLASS 3000 FULL BORE

SIDE ENTRY						
SIZE		D	RJ	B	C	E
2 1/16	in.	2.06	14.61	6.50	4.33	8.50
50	mm	52.4	371	165	110	216
3 1/8	in.	3.12	17.13	7.87	5.00	9.44
80	mm	79.3	435	200	150	240
4 1/16	in.	4.06	20.12	8.27	6.69	11.80
100	mm	103.2	511	210	170	300
5 1/8	in.	5.12	24.13	10.83	10.16	16.65
125	mm	130	613	275	258	423
7 1/16	in.	7.06	28.11	13.78	13.39	15.00
200	mm	179.4	714	350	340	380
9*	in.	9	37.5	22	17.75	35.5
228,6	mm	228	950	560	450	900
11*	in.	11	59	29.5	25.5	51
279,4	mm	280	1500	750	650	1300

API CLASS 3000 REDUCED BORE

SIDE ENTRY							
SIZE		A	D	RJ	B	C	E
2 1/16 x 1 13/16	in.	2.06	2.06	14.61	6.50	4.33	8.50
50 x 40	mm	52.4	52.4	371	165	110	216
3 1/8 x 2 1/16	in.	3.12	3.12	17.13	7.87	5.90	9.49
80 x 50	mm	79.3	79.3	435	200	150	240
4 1/16 x 3 1/8	in.	4.06	4.06	20.12	8.27	6.69	11.61
100 x 80	mm	103.2	103.2	511	210	170	300
5 1/8 x 4 1/16	in.	5.12	5.12	24.13	10.83	10.16	16.65
125 x 100	mm	130	130	613	275	258	423
7 1/16 x 5 1/8	in.	7.06	7.06	28.11	13.78	13.39	15.00
200 x 125	mm	179.4	179.4	714	350	340	381
9 x 7 1/16	in.	9	7	37.5	13.75	13.39	20
230 x 200	mm	990.6	177.8	952.5	349.2	340.1	508
11* x 9	in.	11	9	59	22	17.75	35.5
280 x 230	mm	279.4	990.6	1498	558.8	450.8	901.7

API CLASS 5000 FULL BORE

SIDE ENTRY						
SIZE		D	RJ	B	C	E
2 1/16	in.	2.06	14.61	6.50	4.33	8.50
50	mm	52.4	371	165	110	216
3 1/8	in.	3.12	17.13	7.87	5.90	9.44
80	mm	79.3	435	200	150	240
4 1/16	in.	4.06	20.12	8.27	6.69	11.80
100	mm	103.2	511	210	170	300
5 1/8	in.	5.12	24.13	10.83	10.16	16.65
125	mm	130	613	275	258	423
7 1/16	in.	7.06	28.11	13.78	13.39	15.00
200	mm	179.4	714	350	340	380
9	in.	9	43.3	22.75	18.75	37.5
228,6	mm	228	1100	575	475	950
11*	in.	11	63	30.5	26.5	52.25
279,4	mm	280	1600	775	675	1350

API CLASS 5000 REDUCED BORE

SIDE ENTRY							
SIZE		A	D	RJ	B	C	E
2 1/16 x 1 13/16	in.	2.06	2.06	14.61	6.50	4.33	8.50
50 x 40	mm	52.4	52.4	371	165	110	216
3 1/8 x 2 1/16	in.	3.12	3.12	17.13	7.87	5.90	9.44
80 x 50	mm	79.3	79.3	435	200	150	240
4 1/16 x 3 1/8	in.	4.06	4.06	20.12	8.27	6.69	11.80
100 x 80	mm	103.2	103.2	511	210	170	300
5 1/8 x 4 1/16	in.	5.12	5.12	24.13	10.83	10.16	16.65
125 x 100	mm	130	130	613	275	258	423
7 1/16 x 5 1/8	in.	7.06	7.06	28.11	13.78	13.39	14.90
200 x 125	mm	179.4	179.4	714	350	340	380
9 x 7 1/16	in.	9	7	43.3	13.78	13.39	20
230 x 200	mm	990.6	177.8	1099	350	340	508
11* x 9	in.	11	9	63	22.75	18.75	37.5
280 x 230	mm	279.4	990.6	1600	577.8	476.2	952.5

API CLASS 10000 FULL BORE

SIDE ENTRY *						
SIZE		D	RJ	B	C	E
2 1/16	in.	2.06	14.61	6.50	4.33	8.50
50	mm	52.4	371	165	110	216
3 1/8	in.	3.12	17.13	7.87	5.90	9.44
80	mm	79.3	435	200	150	240
4 1/16	in.	4.06	20.12	8.27	6.69	11.80
100	mm	103.2	511	210	170	300
7 1/16	in.	7	35	19.5	15.5	30.7
200	mm	177.8	889	495.3	393.7	779.8
9*	in.	9	47.25	25.5	19.75	39.5
228,6	mm	228	1200	650	500	1000
11	in.	11	69	35.5	29.5	59
279,4	mm	280	1750	900	750	1500

API CLASS 10000 REDUCED BORE

SIDE ENTRY							
SIZE		A	D	RJ	B	C	E
2 1/16 x 1 13/16	in.	2.06	2.06	14.61	6.50	4.33	8.50
50 x 40	mm	52.4	52.4	371	165	110	216
3 1/8 x 2 1/16	in.	3.12	3.12	17.13	7.87	5.90	9.44
80 x 50	mm	79.3	79.3	435	200	150	240
4 1/16 x 3 1/8	in.	4.06	4.06	20.12	8.27	6.69	11.80
100 x 80	mm	103.2	103.2	511	210	170	300
7 1/16 x 5 1/8	in.	7	5.12	35	15	12	24
200 x 125	mm	177.8	130	889	381	304.8	609.6
9 x 7 1/16	in.	9	7	47.25	19.5	15.5	30.7
230 x 200	mm	990.6	177.8	1200	495.3	393.7	779.8
11* x 9	in.	11	9	69	25.5	19.75	39.5
280 x 230	mm	279.4	990.6	1752	647.7	501.6	1003

*OMB standard, not covered in API 6A

• OMB standard, API 10000 ball valves end to end not cover in API 6A

The valve details on this page are the standard production range only, for other size valves or end configurations please consult the factory. Note OMB reserves the right to make modifications or changes to its production, without prior notice and take no responsibility for any errors in this publication.





OMB Trunnion mounted ball valves are manufactured to API 6D and 6A specifications. The construction is top entry full bore. Lever, gear or actuated options are available in standard and compact designs.

Full Bore valves are suitable for the passage of all types of pipeline scrapper and inspection pigs without causing damage to either the valve or the pig. All valves are designed with anti blow out stem to prevent stem ejection by internal pressure.

Body cavity over pressure is prevented by self relieving seats, For Double Block and or emergency Shut down Valves (ESDV/SSDV) Double Piston Effect Seats will be provided.

CONSTRUCTION

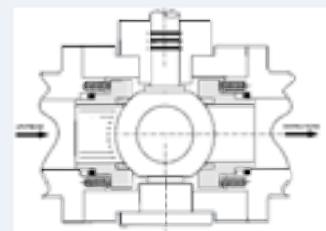

KEY FEATURES ARE:

- ✓ FULL BORE, PIGGABLE
- ✓ BI DIRECTIONAL SEALING.
- ✓ DOUBLE BLOCK CAPABILITIES.
- ✓ BUBBLE TIGHT SEALING.
- ✓ METAL TO METAL SEALING



CLASS DIAMETER	CLASS 150 RB - FB	CLASS 300 RB - FB	CLASS 600 RB - FB	CLASS 900 RB - FB	CLASS 1500 RB - FB	CLASS 2500 RB - FB
1/2"						
3/4"						
1"						
1 1/2"						
2"	●	●	●	●	●	●
3"	●	●	●	●	●	●
4"	●	●	●	●	●	●
6"	●	●	●	●	●	●
8"	●	●	●	●	●	●
10"	●	●	●	●	●	●
12"	●	●	●	●	●	●
14"	●	●	●	●	●	●
16"	●	●	●	●	●	●
18"	●	●	●	●	●	●
20"	●	●	●	●	●	●
22"	●	●	●	●	●	●
24"	●	●	●	●	●	●
26"	●	●	●	●	●	●
28"	●	●	●	●	●	●
30"	●	●	●	●	●	●
32"	●	●	●	●	●	●
34"	●	●	●	●	●	●
36"	●	●	●	●	●	●
40"	●	●	●	●	●	●
42"	●	●	●	●	●	●
48"	●	●	●	●	●	●
56"-60"	●	●	●	●	●	●

CLASS DIAMETER	CLASS 3000 RB - FB	CLASS 5000 RB - FB	CLASS 10.000 RB - FB
1" 13/16	●	●	●
2" 9/16	●	●	●
3" 1/8	●	●	●
4" 1/16	●	●	●
7" 1/16	●	●	●
9"	●	●	●
11"	●	●	●

Applicable Standards

API 6D LICIENCE No 6D-0286

API 6A LICIENCE No 6A-0778

API Spec. Q1

API 6D (EN ISO 14313)
Pipeline Transportation Systems-Pipeline Valves.

API 598 (Inspection Testing)

API 14D Sand Slurry (Annex I API 6A)

ASME B16.34
(Vales-Flanged, Threaded and Welding end)

ASME B16.5 (Pipe Flanges and Flanged Fittings)

ASME B16.10 (Face to Face Dimensions)

ASME B16.25 (Butt weld ends)

ASME
(Boiler and Pressure vessel Code II, V, VIII, X)

ASME B31.8
Gas transmission and Distribution piping systems.

ASME B31.4
Liquid Petroleum transmission piping systems.

BS EN ISO 10497 - Fire Testing.

BS EN 12266 - 1/2. (Testing Of Valves)

BS EN ISO 4406 (Hydraulic Fluid Cleanliness)

BS EN 10204 (Metallic Products Inspection Documents)

EU Pressure Equipment Directive.

EN ISO 9001:2008

ISO 5208 (industrial valves pressure testing)

NACE MR0175/ISO 15156
(Sulphide Stress Cracking Resistant Materials for offshore applications)

NORSOK L-001-Piping and Valves.

NORSOK M-630-Material Data Sheets for Piping.

NORSOK M-650-Qualification of Manufacturers of special materials.

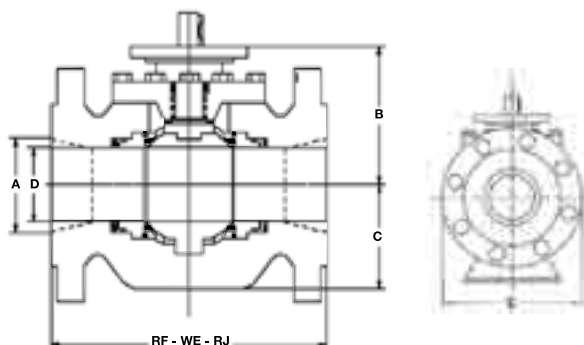

ASME CLASS 150 FULL BORE

SIZE		TOP ENTRY					
		D	RF	WE	B	C	E
2	in.	2.00	7.00	8.50	5.51	3.54	5.00
50	mm	51	178	216	140	90	150
3	in.	3.00	8.00	11.13	7.48	4.13	7.48
80	mm	76	203	283	190	105	190
4	in.	4.00	9.00	12.00	11.02	6.53	9.00
100	mm	102	229	305	280	166	230
6	in.	6.00	15.50	18.00	11.61	6.88	12.20
150	mm	152	394	457	295	175	310
8	in.	8.00	18.00	20.50	12.99	8.26	15.35
200	mm	203	457	521	330	210	390
10	in.	10.00	21.00	22.00	15.74	9.84	18.11
250	mm	254	533	559	400	250	460
12	in.	12.00	24.00	25.00	18.11	12.20	21.45
300	mm	305	610	635	460	310	545
14	in.	14.00	27.00	30.00	18.89	13.38	24.00
350	mm	356	686	762	480	340	610
16	in.	16.00	30.00	33.00	21.25	15.15	26.37
400	mm	406	762	838	540	385	670
18	in.	18.00	34.00	36.00	23.00	16.85	24.80
450	mm	457	864	914	584	428	630
20	in.	20.00	36.00	39.00	24.00	21.45	33.43
500	mm	508	914	991	610	545	849
22	in.	22.00	40.00	43.00	24.10	23.00	36.81
550	mm	559	991	1092	612	584	935
24	in.	24.00	42.00	45.00	30.70	25.78	39.57
600	mm	610	1067	1143	780	655	1005
26	in.	26.00	45.00	49.00	24.69	22.20	41.73
650	mm	660	1143	1245	627	564	1060
28	in.	28.00	49.00	53.00	25.35	25.91	44.88
700	mm	711	1245	1346	644	658	1140
30	in.	30.00	51.00	55.00	27.20	27.70	47.24
750	mm	762	1295	1397	691	705	1200
32	in.	32.00	54.00	60.00	29.21	29.37	51.18
800	mm	813	1372	1524	742	746	1300
34	in.	34.00	58.00	64.00	29.88	30.51	53.94
850	mm	864	1473	1626	759	775	1370
36	in.	36.00	60.00	68.00	31.97	31.77	56.30
900	mm	914	1524	1727	812	807	1430
40	in.	40.00	69.00	77.00	35.43	35.35	63.00
1000	mm	1016	1753	1956	900	898	1600
42	in.	42.00	72.00	82.00	37.13	37.00	64.96
1050	mm	1067	1855	2083	943	940	1656
48	in.	48.00	80.00	94.00	43.19	41.73	75.59
1200	mm	1219	2134	2388	1097	1060	1920

ASME CLASS 150 REDUCED BORE

SIZE		TOP ENTRY						
		A	D	RF	WE	B	C	E
2 x 1/2	in.	2.00	1.50	7.00	8.50	4.00	3.00	5.90
50 x 40	mm	51	38	178	216	101	76	150
3 x 2	in.	3.00	2.00	8.00	11.13	5.51	3.54	7.48
80 x 50	mm	76	51	203	283	140	90	190
4 x 3	in.	4.00	3.00	9.00	12.00	7.48	4.13	9.00
100 x 80	mm	102	76	229	305	190	105	230
6 x 4	in.	6.00	4.00	15.50	18.00	11.02	6.53	12.20
150 x 100	mm	152	102	394	457	280	166	310
8 x 6	in.	8.00	6.00	18.00	20.50	11.61	6.88	15.35
200 x 150	mm	203	152	457	521	295	175	390
10 x 8	in.	10.00	8.00	21.00	22.00	12.99	8.26	15.98
250 x 200	mm	254	203	533	559	330	210	460
12 x 10	in.	12.00	10.00	24.00	25.00	15.74	9.84	19.02
300 x 250	mm	305	254	610	635	400	250	483
14 x 10	in.	14.00	10.00	27.00	30.00	18.11	12.30	21.06
350 x 250	mm	356	254	686	762	460	310	535
14 x 12	in.	14.00	12.00	27.00	30.00	18.11	12.20	21.06
350 x 250	mm	356	305	686	762	460	310	535
16 x 12	in.	16.00	12.00	30.00	33.00	18.89	13.38	23.43
400 x 300	mm	406	305	762	838	480	340	595
16 x 14	in.	16.00	14.00	30.00	33.00	18.89	13.38	23.43
400 x 350	mm	406	356	762	838	480	340	595
18 x 16	in.	18.00	16.00	34.00	36.00	21.25	15.15	24.80
450 x 400	mm	457	406	864	914	540	385	630
20 x 16	in.	20.00	16.00	36.00	39.00	22.83	16.85	27.56
500 x 400	mm	508	406	914	991	580	428	700
20 x 18	in.	20.00	18.00	36.00	39.00	22.84	16.85	27.56
500 x 450	mm	508	457	914	991	580	428	700
24 x 20	in.	24.00	20.00	42.00	45.00	23.00	18.00	32.28
600 x 500	mm	610	508	1067	1143	584	457	820
30 x 24	in.	30.00	24.00	51.00	55.00	25.15	19.49	38.78
750 x 600	mm	762	610	1295	1397	638	495	985
36 x 30	in.	36.00	30.00	60.00	68.00	27.17	27.56	46.06
900 x 750	mm	914	762	1524	1727	690	700	1170

The valve details on this page are the standard production range only, for other size valves or end configurations please consult the factory.
 Note OMB reserves the right to make modifications or changes to its production, without prior notice and take no responsibility for any errors in this publication.



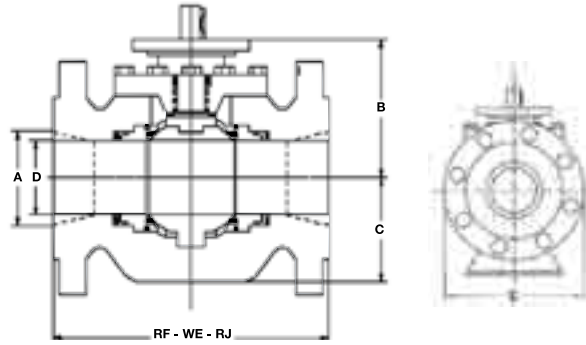

ASME CLASS 300 FULL BORE

SIZE		TOP ENTRY					
		D	RF	WE	B	C	E
2	in.	2.00	8.50	8.50	7.87	4.72	6.50
50	mm	51	216	216	200	120	165
3	in.	3.00	11.10	11.10	9.44	5.11	8.50
80	mm	76	283	283	240	130	218
4	in.	4.00	12.00	12.00	11.02	5.90	10.00
100	mm	102	305	305	280	150	254
6	in.	6.00	15.90	18.00	11.61	6.88	12.20
150	mm	152	457	457	295	175	310
8	in.	8.00	19.80	20.50	12.99	8.26	15.40
200	mm	203	502	521	330	210	390
10	in.	10.00	22.40	22.00	16.53	10.62	18.50
250	mm	254	568	559	420	270	470
12	in.	12.00	25.50	25.00	18.30	12.79	21.30
300	mm	305	648	635	465	325	545
14	in.	14.00	30.00	30.00	21.45	16.92	24.80
350	mm	356	762	762	545	430	630
16	in.	16.00	33.00	33.00	23.62	18.50	27.20
400	mm	406	838	838	600	470	690
18	in.	18.00	36.00	36.00	23.10	20.07	30.30
450	mm	457	914	914	586	510	770
20	in.	20.00	39.00	39.00	23.90	19.68	33.50
500	mm	508	991	991	607	500	850
22	in.	22.00	43.00	43.00	24.01	21.00	37.00
550	mm	559	1092	1092	612	533	940
24	in.	24.00	45.00	45.00	24.50	23.62	39.70
600	mm	610	1143	1143	622	600	1010
26	in.	26.00	49.00	49.00	24.80	22.80	42.50
650	mm	660	1245	1245	630	580	1080
28	in.	28.00	53.00	53.00	25.20	26.60	45.30
700	mm	711	1346	1346	640	675	1150
30	in.	30.00	55.00	55.00	27.60	28.70	48.40
750	mm	762	1397	1397	700	730	1230
32	in.	32.00	60.00	60.00	29.30	29.90	52.00
800	mm	813	1524	1524	745	760	1320
34	in.	34.00	64.00	64.00	29.90	31.50	54.50
850	mm	864	1626	1626	760	800	1380
36	in.	36.00	68.00	68.00	31.70	32.5	56.9
900	mm	914	1727	1727	805	825	1445
40	in.	40.00	77.00	77.00	35.40	36.2	64.10
1000	mm	1016	1956	1956	900	920	1630
42	in.	42.00	82.00	82.00	38.10	38.40	66.90
1050	mm	1067	2083	2083	968	980	1700
48	in.	48.00	85.40	85.40	43.30	45.60	74.80
1200	mm	1219	2170	2170	1100	1160	1960

ASME CLASS 300 REDUCED BORE

SIZE		TOP ENTRY						
		A	D	RF	WE	B	C	E
2 x 1/2	in.	2.00	1.50	8.50	8.50	8.22	2.75	6.50
50 x 40	mm	51	38	216	216	209	70	165
3 x 2	in.	3.00	2.00	11.10	11.10	7.87	4.72	8.50
80 x 50	mm	76	51	283	283	200	120	218
4 x 3	in.	4.00	3.00	12.00	12.00	9.44	5.11	10.00
100 x 80	mm	102	76	305	305	240	130	254
6 x 4	in.	6.00	4.00	15.90	18.00	11.02	5.90	12.20
150 x 100	mm	152	102	457	457	280	150	310
8 x 6	in.	8.00	6.00	19.80	20.50	11.61	6.88	15.40
200 x 150	mm	203	152	502	521	295	175	390
10 x 8	in.	10.00	8.00	22.40	22.00	12.99	8.26	18.50
250 x 200	mm	254	203	568	559	330	210	445
12 x 10	in.	12.00	10.00	25.50	25.00	16.53	10.62	20.50
300 x 250	mm	305	254	648	635	420	270	520
14 x 10	in.	14.00	10.00	30.00	30.00	-	-	23.00
350 x 250	mm	356	254	762	762	-	-	585
14 x 12	in.	14.00	12.00	30.00	30.00	18.30	12.79	23.00
350 x 250	mm	356	305	762	762	465	325	585
16 x 12	in.	16.00	12.00	33.00	33.00	-	-	25.60
400 x 300	mm	406	305	838	838	-	-	650
16 x 14	in.	16.00	14.00	33.00	33.00	21.45	16.92	25.60
400 x 350	mm	406	356	838	838	545	430	650
18 x 16	in.	18.00	16.00	36.00	36.00	23.62	18.50	28.00
450 x 400	mm	457	406	914	914	600	470	710
20 x 16	in.	20.00	16.00	39.00	39.00	-	-	30.70
500 x 400	mm	508	406	991	991	-	-	780
20 x 18	in.	20.00	18.00	39.00	39.00	24.40	20.07	30.40
500 x 450	mm	508	457	991	991	620	510	780
24 x 20	in.	24.00	20.00	45.00	45.00	28.89	19.68	36.00
600 x 500	mm	610	508	1143	1143	734	500	915
30 x 24	in.	30.00	24.00	55.00	55.00	-	-	42.90
750 x 600	mm	762	610	1397	1397	-	-	1090
36 x 30	in.	36.00	30.00	68.00	68.00	-	-	50.00
900 x 750	mm	914	762	1727	1727	-	-	1270

The valve details on this page are the standard production range only, for other size valves or end configurations please consult the factory.
 Note OMB reserves the right to make modifications or changes to its production, without prior notice and take no responsibility for any errors in this publication.



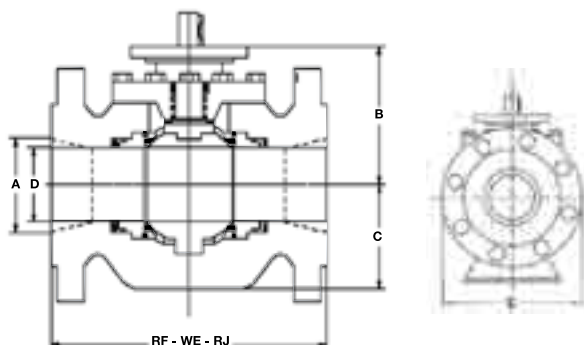

ASME CLASS 600 FULL BORE

SIZE		TOP ENTRY						
SIZE		D	RF	RJ	WE	B	C	E
2	in.	2.00	11.50	11.63	11.50	7.67	4.33	6.50
50	mm	51	292	295	292	195	110	165
3	in.	3.00	14.00	14.13	14.00	9.44	4.33	8.50
80	mm	76	356	359	356	240	110	218
4	in.	4.00	17.00	17.13	17.00	11.02	6.88	10.70
100	mm	102	432	435	432	280	175	273
6	in.	6.00	22.00	22.13	22.00	12.00	7.67	14.10
150	mm	152	559	562	559	305	195	360
8	in.	8.00	26.00	26.13	26.00	15.74	11.02	16.50
200	mm	203	660	664	660	400	280	419
10	in.	10.00	31.00	31.13	31.00	17.12	11.22	20.40
250	mm	254	787	791	787	435	285	520
12	in.	12.00	33.00	33.13	33.00	17.32	12.59	22.60
300	mm	305	838	841	838	440	320	575
14	in.	14.00	35.00	35.13	35.00	19.88	13.38	24.70
350	mm	356	889	892	889	505	340	628
16	in.	16.00	39.00	39.13	39.00	23.22	16.14	27.60
400	mm	406	991	994	991	590	410	700
18	in.	18.00	43.00	43.13	43.00	23.55	17.51	30.50
450	mm	457	1092	1095	1092	589	445	775
20	in.	20.00	47.00	47.25	47.00	23.80	20.07	34.10
500	mm	508	1194	1200	1194	604	510	865
22	in.	22.00	51.00	51.38	51.00	24.00	20.35	37.40
550	mm	559	1295	1305	1295	609	571	950
24	in.	24.00	55.00	55.38	55.00	24.50	25.19	40.50
600	mm	610	1397	1407	1397	622	640	1028
26	in.	26.00	57.00	57.50	57.00	24.80	24.30	40.10
650	mm	660	1448	1461	1448	630	618	1020
28	in.	28.00	61.00	61.50	61.00	26.20	27.20	46.10
700	mm	711	1549	1562	1549	665	692	1172
30	in.	30.00	66.30	66.50	66.30	29.20	31.50	50.80
750	mm	762	1651	1664	1651	741	800	1290
32	in.	32.00	70.00	70.72	70.00	29.80	31.70	52.40
800	mm	813	1778	1794	1778	756	804	1330
34	in.	34.00	76.00	76.52	76.00	30.80	32.20	57.10
850	mm	864	1930	1946	1930	782	817	1450
36	in.	36.00	82.00	82.63	82.00	34.20	37.20	60.90
900	mm	914	2083	2099	2083	869	945	1546
40	in.	40.00	85.40	85.43	85.40	36.10	38.60	64.80
1000	mm	1016	2170	2170	2170	916	980	1645
42	in.	42.00	85.60	85.63	85.60	39.20	43.70	70.80
1050	mm	1067	2175	2175	2175	995	1110	1800
48	in.	48.00	95.90	95.87	95.90	44.60	49.80	81.50
1200	mm	1219	2435	2435	2435	1132	1265	2070

ASME CLASS 600 REDUCED BORE

SIZE		TOP ENTRY							
SIZE		A	D	RF	RJ	WE	B	C	E
2 x 1/2	in.	2.00	1.50	11.50	11.63	11.50	8.22	2.75	6.50
50 x 40	mm	51	38	292	295	292	209	70	165
3 x 2	in.	3.00	2.00	14.00	14.13	14.00	7.67	4.33	8.30
80 x 50	mm	76	51	356	359	356	195	110	210
4 x 3	in.	4.00	3.00	17.00	17.13	17.00	9.44	4.33	14.70
100 x 80	mm	102	76	432	435	432	240	110	373
6 x 4	in.	6.00	4.00	22.00	22.13	22.00	11.02	6.88	14.00
150 x 100	mm	152	102	559	562	559	280	175	356
8 x 6	in.	8.00	6.00	26.00	26.13	26.00	12.00	7.67	16.50
200 x 150	mm	203	152	660	664	660	305	195	419
10 x 8	in.	10.00	8.00	31.00	31.13	31.00	15.74	11.02	20.10
250 x 200	mm	254	203	787	791	787	400	280	510
12 x 10	in.	12.00	10.00	33.00	33.13	33.00	17.12	11.22	22.00
300 x 250	mm	305	254	838	841	838	435	285	560
14 x 10	in.	14.00	10.00	35.00	35.13	35.00	—	—	23.80
350 x 250	mm	356	254	889	892	889	—	—	605
14 x 12	in.	14.00	12.00	35.00	35.13	35.00	17.32	12.59	23.80
350 x 250	mm	356	305	889	892	889	440	320	605
16 x 12	in.	16.00	12.00	39.00	39.13	39.00	—	—	27.00
400 x 300	mm	406	305	991	994	991	—	—	685
16 x 14	in.	16.00	14.00	39.00	39.13	39.00	19.88	13.38	24.70
400 x 350	mm	406	356	991	994	991	505	340	628
18 x 16	in.	18.00	16.00	43.00	43.13	43.00	23.22	16.14	29.30
450 x 400	mm	457	406	1092	1095	1092	590	410	745
20 x 16	in.	20.00	16.00	47.00	47.25	47.00	—	—	32.10
500 x 400	mm	508	406	1194	1200	1194	—	—	815
20 x 18	in.	20.00	18.00	47.00	47.25	47.00	27.55	17.51	32.10
500 x 450	mm	508	457	1194	1200	1194	700	445	815
24 x 20	in.	24.00	20.00	55.00	55.38	55.00	30.51	20.07	37.00
600 x 500	mm	610	508	1397	1407	1397	775	510	940
30 x 24	in.	30.00	24.00	66.30	66.50	66.30	—	—	44.50
750 x 600	mm	762	610	1651	1664	1651	—	—	1130
36 x 30	in.	36.00	30.00	82.00	82.63	82.00	—	—	51.80
900 x 750	mm	914	762	2083	2099	2083	—	—	1315

The valve details on this page are the standard production range only, for other size valves or end configurations please consult the factory.
 Note OMB reserves the right to make modifications or changes to its production, without prior notice and take no responsibility for any errors in this publication.



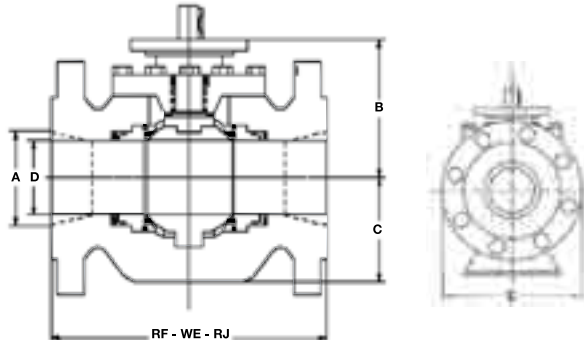

ASME CLASS 900 FULL BORE

SIZE		TOP ENTRY						
		D	RF	RJ	WE	B	C	E
2	in.	2.00	14.49	14.61	14.49	7.87	4.72	8.50
50	mm	51	368	371	368	200	120	220
3	in.	3.00	15.00	15.12	15.00	9.44	5.11	9.49
80	mm	76	381	384	381	240	130	241
4	in.	4.00	17.99	18.11	17.99	11.02	6.88	11.50
100	mm	102	457	460	457	280	175	290
6	in.	6.00	24.02	24.13	24.02	13.77	8.66	15.00
150	mm	152	610	613	610	350	220	381
8	in.	8.00	29.02	29.13	29.02	15.35	10.23	18.50
200	mm	203	737	740	737	390	260	470
10	in.	10.00	32.99	33.11	32.99	18.89	14.20	21.46
250	mm	254	838	841	838	480	310	545
12	in.	12.00	37.99	38.11	37.99	17.24	16.14	24.02
300	mm	305	965	968	965	438	410	610
14	in.	14.00	40.51	40.87	40.51	21.45	14.56	25.50
350	mm	356	1029	1038	1029	545	370	650
16	in.	16.00	44.49	44.88	44.49	25.59	16.53	27.95
400	mm	406	1130	1140	1130	650	420	710
18	in.	18.00	47.99	48.50	47.99	26.57	24.29	31.50
450	mm	457	1219	1232	1219	675	617	800
20	in.	20.00	52.01	52.48	52.01	31.10	28.54	35.04
500	mm	508	1321	1334	1321	790	725	890
24	in.	24.00	60.98	61.73	60.98	36.02	32.71	41.69
600	mm	610	1549	1568	1549	915	831	1059
28	in.	28.00	69.02	69.88	69.02	—	—	48.58
700	mm	711	1753	1775	1753	—	—	1234
30	in.	30.00	74.02	74.88	74.02	—	—	51.18
750	mm	762	1880	1902	1880	—	—	1300
32	in.	32.00	80.00	80.87	80.00	—	—	53.43
800	mm	813	2032	2054	2032	—	—	1357
34	in.	34.00	85.00	86.14	85.00	—	—	57.80
850	mm	864	2159	2188	2159	—	—	1468
36	in.	36.00	90.00	91.14	90.00	—	—	60.31
900	mm	914	2286	2315	2286	—	—	1532

ASME CLASS 900 REDUCED BORE

SIZE		TOP ENTRY							
		A	D	RF	RJ	WE	B	C	E
2 x 1/2	in.	2.00	1.50	14.49	14.61	14.49	8.46	3.14	8.60
50 x 40	mm	51	38	368	371	368	215	80	220
3 x 2	in.	3.00	2.00	15.00	15.12	15.00	7.87	4.72	9.49
80 x 50	mm	76	51	381	384	381	200	120	241
4 x 3	in.	4.00	3.00	17.99	18.11	17.99	9.44	5.11	11.50
100 x 80	mm	102	76	457	460	457	240	130	290
6 x 4	in.	6.00	4.00	24.02	24.13	24.02	11.02	6.88	14.90
150 x 100	mm	152	102	610	613	610	280	175	380
8 x 6	in.	8.00	6.00	29.02	29.13	29.02	13.77	8.66	18.50
200 x 150	mm	203	152	737	740	737	350	220	470
10 x 8	in.	10.00	8.00	32.99	33.11	32.99	15.35	10.23	21.46
250 x 200	mm	254	203	838	841	838	390	260	545
12 x 10	in.	12.00	10.00	37.99	38.11	37.99	18.89	14.20	24.02
300 x 250	mm	305	254	965	968	965	480	310	610
14 x 10	in.	14.00	10.00	40.51	40.87	40.51	—	—	25.50
350 x 250	mm	356	254	1029	1038	1029	—	—	650
14 x 12	in.	14.00	12.00	40.51	40.87	40.51	17.24	16.14	27.90
350 x 300	mm	356	305	1029	1038	1029	438	410	710
16 x 12	in.	16.00	12.00	44.49	44.88	44.49	—	—	29.50
400 x 300	mm	406	305	1130	1140	1130	—	—	750
16 x 14	in.	16.00	14.00	44.49	44.88	44.49	21.45	14.56	31.10
400 x 350	mm	406	356	1130	1140	1130	545	370	790
18 x 16	in.	18.00	16.00	47.99	48.50	47.99	25.59	16.53	31.50
450 x 400	mm	457	406	1219	1232	1219	650	420	800
20 x 16	in.	20.00	16.00	52.01	52.48	52.01	—	—	31.10
500 x 400	mm	508	406	1321	1334	1321	—	—	790
20 x 18	in.	20.00	18.00	52.01	52.48	52.01	26.57	24.29	35.04
500 x 450	mm	508	457	1321	1334	1321	675	617	890
24 x 20	in.	24.00	20.00	60.98	61.73	60.98	31.10	28.54	40.94
600 x 500	mm	610	508	1549	1568	1549	790	725	1040
30 x 24	in.	30.00	24.00	74.02	74.88	74.02	—	—	48.43
750 x 600	mm	762	610	1880	1902	1880	—	—	1230
36 x 30	in.	36.00	30.00	90.00	91.14	90.00	—	—	57.48
900 x 750	mm	914	762	2286	2315	2286	—	—	1460

The valve details on this page are the standard production range only, for other size valves or end configurations please consult the factory. Note OMB reserves the right to make modifications or changes to its production, without prior notice and take no responsibility for any errors in this publication.



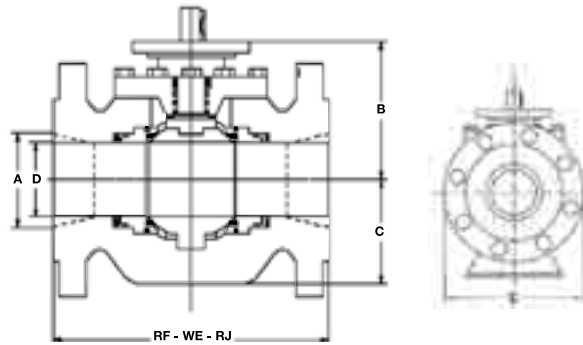

ASME CLASS 1500 FULL BORE

TOP ENTRY								
SIZE		D	RF	RJ	WE	B	C	E
2	in.	2.00	14.49	14.61	14.49	8.07	4.72	8.60
50	mm	51	368	371	368	205	120	220
3	in.	3.00	18.50	18.62	18.50	8.26	4.92	10.51
80	mm	76	470	473	470	210	125	267
4	in.	4.00	21.50	21.61	21.50	9.64	6.29	12.20
100	mm	102	546	549	546	245	160	310
6	in.	6.00	27.76	27.99	27.76	13.18	10.03	15.51
150	mm	152	705	711	705	335	255	394
8	in.	8.00	32.76	33.11	32.76	17.20	13.38	19.09
200	mm	203	832	841	832	437	340	485
10	in.	10.00	39.02	39.37	39.02	19.76	15.00	23.03
250	mm	254	991	1000	991	502	381	585
12	in.	12.00	44.49	44.61	44.49	20.98	17.24	27.95
300	mm	305	1130	1146	1130	533	438	710
14	in.	14.00	49.49	50.24	49.49	24.64	19.60	30.12
350	mm	356	1257	1276	1257	626	498	765
16	in.	16.00	54.49	55.35	54.49	28.54	18.11	33.39
400	mm	406	1384	1407	1384	725	460	848
18	in.	18.00	60.51	61.38	60.51	29.00	23.90	38.58
450	mm	457	1537	1559	1537	736	607	980
20	in.	20.00	65.51	66.38	65.51	30.00	25.40	39.96
500	mm	508	1664	1686	1664	763	644	1015
24	in.	24.00	80.43	81.54	80.43	32.00	28.50	50.91
600	mm	610	2043	1972	2043	813	725	1295

ASME CLASS 1500 REDUCED BORE

TOP ENTRY									
SIZE		A	D	RF	RJ	WE	B	C	E
2 x 1/2	in.	2.00	1.50	14.49	14.61	14.49	7.48	4.33	8.66
50 x 40	mm	51	38	368	371	368	190	110	220
3 x 2	in.	3.00	2.00	18.50	18.62	18.50	8.07	4.72	10.51
80 x 50	mm	76	51	470	473	470	205	120	2.67
4 x 3	in.	4.00	3.00	21.50	21.61	21.50	8.26	4.92	12.20
100 x 80	mm	102	76	546	549	546	210	125	310
6 x 4	in.	6.00	4.00	27.76	27.99	27.76	9.64	6.29	15.51
150 x 100	mm	152	102	705	711	705	245	160	394
8 x 6	in.	8.00	6.00	32.76	33.11	32.76	13.18	10.03	19.09
200 x 150	mm	203	152	832	841	832	335	255	485
10 x 8	in.	10.00	8.00	39.02	39.37	39.02	16.14	11.41	23.03
250 x 200	mm	254	203	991	1000	991	410	290	585
12 x 10	in.	12.00	10.00	44.49	44.61	44.49	18.30	13.18	26.57
300 x 250	mm	305	254	1130	1146	1130	465	335	675
14 x 10	in.	14.00	10.00	49.49	50.24	49.49	21.77	17.24	27.95
350 x 250	mm	356	254	1257	1276	1257	553	439	710
14 x 12	in.	14.00	12.00	49.49	50.24	49.49	21.77	17.24	29.92
350 x 300	mm	356	305	1257	1276	1257	553	438	760
16 x 12	in.	16.00	12.00	54.49	55.35	54.49	24.64	19.60	32.48
400 x 300	mm	406	305	1384	1407	1384	626	498	825
16 x 14	in.	16.00	14.00	54.49	55.35	54.49	24.64	19.60	32.48
400 x 350	mm	406	356	1384	1407	1384	626	498	825
18 x 16	in.	18.00	16.00	60.51	61.38	60.51	25.00	20.00	36.22
450 x 400	mm	457	406	1537	1559	1537	630	508	920
20 x 16	in.	20.00	16.00	65.51	66.38	66.51	26.00	20.00	38.97
500 x 400	mm	508	406	1664	1686	1664	660	508	990
20 x 18	in.	20.00	18.00	65.51	66.38	66.51	28.00	23.00	38.97
500 x 450	mm	508	457	1664	1686	1664	711	542	990
24 x 20	in.	24.00	20.00	80.43	81.54	80.43	30.00	25.00	46.06
600 x 500	mm	610	508	2043	1972	2043	762	635	1170

ASME CLASS 2500 FULL BORE

TOP ENTRY								
SIZE		D	RF	RJ	WE	B	C	E
2	in.	1.65	17.76	17.87	17.76	8.46	5.11	9.05
50	mm	42	451	454	451	215	130	230
3	in.	2.44	22.76	22.99	22.76	8.66	5.31	11.08
80	mm	62	578	584	578	220	135	300
4	in.	3.43	26.50	26.89	26.50	10.03	6.96	14.02
100	mm	87	673	683	673	255	170	356
6	in.	5.16	35.98	36.50	35.98	16.92	10.43	19.09
150	mm	131	914	927	914	430	265	485
8	in.	7.05	40.24	40.87	40.24	16.92	13.30	24.41
200	mm	179	1022	1038	1022	430	340	620
10	in.	8.78	50.00	50.87	50.00	17.50	16.60	29.33
250	mm	223	1270	1292	1270	444	421	745
12	in.	10.43	55.98	56.89	55.98	18.00	18.90	34.44
300	mm	265	1422	1445	1422	457	480	875

ASME CLASS 2500 REDUCED BORE

TOP ENTRY									
SIZE		A	D	RF	RJ	WE	B	C	E
2 x 1/2	in.	1.65	1.50	17.76	17.87	17.76	7.78	4.72	9.25
50 x 40	mm	42	38	451	454	451	200	120	230
3 x 2	in.	2.44	1.65	22.76	22.99	22.76	8.46	5.11	11.01
80 x 50	mm	62	42	578	584	578	215	130	300
4 x 3	in.	3.43	2.44	26.50	26.89	26.50	8.66	5.31	14.02
100 x 80	mm	87	62	673	683	673	220	135	356
6 x 4	in.	5.16	3.43	35.98	36.50	35.98	10.03	6.96	19.09
150 x 100	mm	131	87	914	927	914	255	170	485
8 x 6	in.	7.05	5.16	40.24	40.87	40.24	12.00	9.00	22.05
200 x 150	mm	179	131	1022	1038	1022	348	228	560
10 x 8	in.	8.78	7.05	50.00	50.87	50.00	14.00	13.00	26.57
250 x 200	mm	223	179	1270	1292	1270	355	330	670
12 x 10	in.	10.43	8.78	55.98	56.89	55.98	16.00	18.00	30.70
300 x 250	mm	265	223	1422	1445	1422	406	475	780

The valve details on this page are the standard production range only, for other size valves or end configurations please consult the factory.
 Note OMB reserves the right to make modifications or changes to its production, without prior notice and take no responsibility for any errors in this publication.



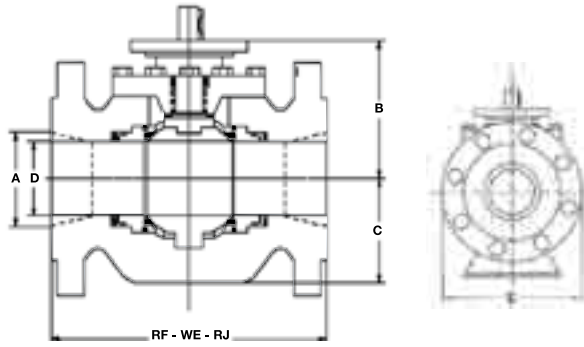

API CLASS 3000 FULL BORE

SIZE		TOP ENTRY				
		D	RJ	B	C	E
2 1/16	in.	2.06	14.61	6.50	4.33	8.50
50	mm	52.4	371	165	110	216
3 1/8	in.	3.12	17.13	7.87	5.00	9.44
80	mm	79.3	435	200	150	240
4 1/16	in.	4.06	20.12	8.27	6.69	11.80
100	mm	103.2	511	210	170	300
5 1/8	in.	5.12	24.13	10.83	10.16	16.65
125	mm	130	613	275	258	423
7 1/16	in.	7.06	28.11	13.78	13.39	15.00
200	mm	179.4	714	350	340	380
9*	in.	9	37.5	22	17.75	35.5
228,6	mm	228	950	560	450	900
11*	in.	11	59	29.5	25.5	51
279,4	mm	280	1500	750	650	1300

API CLASS 3000 REDUCED BORE

SIZE		TOP ENTRY					
		A	D	RJ	B	C	E
2 1/16 x 1 13/16	in.	2.06	2.06	14.61	6.50	4.33	8.50
50 x 40	mm	52.4	52.4	371	165	110	216
3 1/8 x 2 1/16	in.	3.12	3.12	17.13	7.87	5.90	9.49
80 x 50	mm	79.3	79.3	435	200	150	240
4 1/16 x 3 1/8	in.	4.06	4.06	20.12	8.27	6.69	11.61
100 x 80	mm	103.2	103.2	511	210	170	300
5 1/8 x 4 1/16	in.	5.12	5.12	24.13	10.83	10.16	16.65
125 x 100	mm	130	130	613	275	258	423
7 1/16 x 5 1/8	in.	7.06	7.06	28.11	13.78	13.39	15.00
200 x 150	mm	179.4	179.4	714	350	340	381
9 x 7 1/16	in.	9	7	37.5	13.75	13.39	20
230 x 200	mm	990.6	177.8	952.5	349.2	340.1	508
11* x 9	in.	11	9	59	22	17.75	35.5
280 x 230	mm	279.4	990.6	1498	558.8	450.8	901.7

API CLASS 5000 FULL BORE

SIZE		TOP ENTRY				
		D	RJ	B	C	E
2 1/16	in.	2.06	14.61	6.50	4.33	8.50
50	mm	52.4	371	165	110	216
3 1/8	in.	3.12	17.13	7.87	5.90	9.44
80	mm	79.3	435	200	150	240
4 1/16	in.	4.06	20.12	8.27	6.69	11.80
100	mm	103.2	511	210	170	300
5 1/8	in.	5.12	24.13	10.83	10.16	16.65
125	mm	130	613	275	258	423
7 1/16	in.	7.06	28.11	13.78	13.39	15.00
200	mm	179.4	714	350	340	380
9	in.	9	43.3	22.75	18.75	37.5
228,6	mm	228	1100	575	475	950
11*	in.	11	63	30.5	26.5	52.25
279,4	mm	280	1600	775	675	1350

API CLASS 5000 REDUCED BORE

SIZE		TOP ENTRY					
		A	D	RJ	B	C	E
2 1/16 x 1 13/16	in.	2.06	2.06	14.61	6.50	4.33	8.50
50 x 40	mm	52.4	52.4	371	165	110	216
3 1/8 x 2 1/16	in.	3.12	3.12	17.13	7.87	5.90	9.44
80 x 50	mm	79.3	79.3	435	200	150	240
4 1/16 x 3 1/8	in.	4.06	4.06	20.12	8.27	6.69	11.80
100 x 80	mm	103.2	103.2	511	210	170	300
5 1/8 x 4 1/16	in.	5.12	5.12	24.13	10.83	10.16	16.65
125 x 100	mm	130	130	613	275	258	423
7 1/16 x 5 1/8	in.	7.06	7.06	28.11	13.78	13.39	14.90
200 x 125	mm	179.4	179.4	714	350	340	380
9 x 7 1/16	in.	9	7	43.3	13.78	13.39	20
230 x 200	mm	990.6	177.8	1099	350	340	508
11* x 9	in.	11	9	63	22.75	18.75	37.5
280 x 230	mm	279.4	990.6	1600	577.8	476.2	952.5

API CLASS 10000 FULL BORE

SIZE		TOP ENTRY*				
		D	RJ	B	C	E
2 1/16	in.	2.06	14.61	6.50	4.33	8.50
50	mm	52.4	371	165	110	216
3 1/8	in.	3.12	17.13	7.87	5.90	9.44
80	mm	79.3	435	200	150	240
4 1/16	in.	4.06	20.12	8.27	6.69	11.80
100	mm	103.2	511	210	170	300
7 1/16	in.	7	35	19.5	15.5	30.7
200	mm	177.8	889	495.3	393.7	779.8
9*	in.	9	47.25	25.5	19.75	39.5
228,6	mm	228	1200	650	500	1000
11	in.	11	69	35.5	29.5	59
279,4	mm	280	1750	900	750	1500

API CLASS 10000 REDUCED BORE

SIZE		TOP ENTRY					
		A	D	RJ	B	C	E
2 1/16 x 1 13/16	in.	2.06	2.06	14.61	6.50	4.33	8.50
50 x 40	mm	52.4	52.4	371	165	110	216
3 1/8 x 2 1/16	in.	3.12	3.12	17.13	7.87	5.90	9.44
80 x 50	mm	79.3	79.3	435	200	150	240
4 1/16 x 3 1/8	in.	4.06	4.06	20.12	8.27	6.69	11.80
100 x 80	mm	103.2	103.2	511	210	170	300
7 1/16 x 5 1/8	in.	7	5.12	35	15	12	24
200 x 125	mm	177.8	130	889	381	304.8	609.6
9 x 7 1/16	in.	9	7	47.25	19.5	15.5	30.7
230 x 200	mm	990.6	177.8	1200	495.3	393.7	779.8
11* x 9	in.	11	9	69	25.5	19.75	39.5
280 x 230	mm	279.4	990.6	1752	647.7	501.6	1003

*OMB standard, not covered in API 6A

• OMB standard, API 10000 ball valves end to end not cover in API 6A

The valve details on this page are the standard production range only, for other size valves or end configurations please consult the factory. Note OMB reserves the right to make modifications or changes to its production, without prior notice and take no responsibility for any errors in this publication.





OMB manufactures both API 6A & 6D compliant Through Conduit Gate Valves (TCGV) designed as full bore, slab gate with primary downstream sealing, non-rising stem, and floating seats for positive bubble tight shut off and sealing at high and low differential pressure. Fully piggable designs ensure that the seats are well protected from process solids and gate skirts minimise the level of solids entering the valve cavity during valve operation. OMB utilizes multi stems seals to provide a secure multi barrier to the atmosphere. Seats are sealed to the body via lip seal, these seals are energized with Springs to provide a mechanical pre load. The seat to gate metal to metal sealing surface is Tungsten Carbide coated providing high resistance to erosion whilst maintaining a low coefficient of friction. As part of our standard supply for manual and

hydraulically actuated gate valves a metal to metal back seat seal is provided with the gate in the closed position. Mechanical end stops are provided to ensure correct bore alignment and the setting of position indication. Body cavity plugs are supplied for the purpose of providing flushing, drain and vent facilities with high integrity sealing capabilities.

CONSTRUCTION

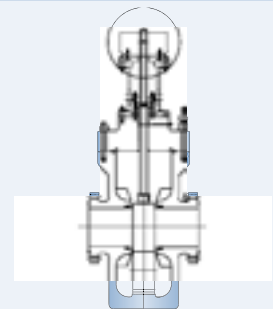

KEY FEATURES ARE:

- ✓ FULL BORE, PIGGABLE
- ✓ BI DIRECTIONAL SEALING.
- ✓ BUBBLE TIGHT SEALING.
- ✓ METAL TO METAL SEALING



CLASS DIAMETER	CLASS 150 FB	CLASS 300 FB	CLASS 600 FB	CLASS 900 FB	CLASS 1500 FB	CLASS 2500 FB
1/2"						
3/4"						
1"						
1 1/2"						
2"	●	●	●	●	●	●
3"	●	●	●	●	●	●
4"	●	●	●	●	●	●
6"	●	●	●	●	●	●
8"	●	●	●	●	●	●
10"	●	●	●	●	●	●
12"	●	●	●	●	●	●
14"	●	●	●	●	●	
16"	●	●	●	●	●	
18"	●	●	●	●	●	
20"	●	●	●	●	●	
22"	●	●	●	●	●	
24"	●	●	●	●	●	
26"	●	●	●	●	●	
28"	●	●	●	●	●	
30"	●	●	●	●	●	
32"	●	●	●	●	●	
34"	●	●	●	●	●	
36"	●	●	●	●	●	

Applicable Standards

API 6D LICIENCE No 6D-0286

API 6A LICIENCE No 6A-0778

API Spec. Q1

API 6D (EN ISO 14313) Pipeline Transportation Systems-Pipeline Valves.

API 598 (Inspection Testing)

API 14D Sand Slurry (Annex I API 6A)

ASME B16.34

(Valves-Flanged, Threaded and Welding end)

ASME B16.5 (Pipe Flanges and Flanged Fittings)

ASME B16.10 (Face to Face Dimensions)

ASME B16.25 (Butt weld ends)

ASME

(Boiler and Pressure vessel Code II, V, VIII, X)

ASME B31.8

Gas transmission and Distribution piping systems.

ASME B31.4

Liquid Petroleum transmission piping systems.

BS EN ISO 10497-Fire Testing.

BS EN 12266 – 1/2. (Testing Of Valves)

BS EN ISO 4406 (Hydraulic Fluid Cleanliness)

BS EN 10204 (Metallic Products Inspection Documents)

EU Pressure Equipment Directive.

EN ISO 9001:2008

ISO 5208 (industrial valves pressure testing)

NACE MR0175 / ISO 15156

(Sulphide Stress Cracking Resistant Materials for offshore applications)

NORSOK L-001 - Piping and Valves.

NORSOK M-630 - Material Data Sheets for Piping.

NORSOK M-650 - Qualification of Manufacturers of special materials.



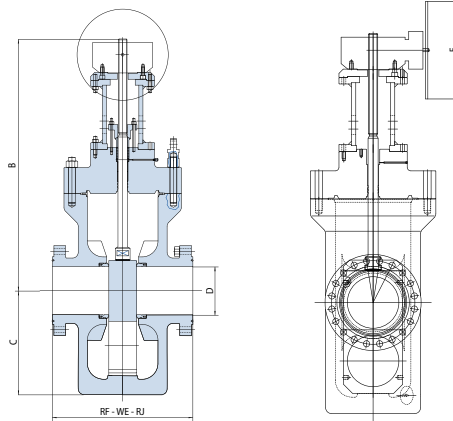

ASME CLASS 150 FULL BORE

SLAB							
SIZE		D	RF	WE	B	C	E
2	in.	2.00	7.00	8.50	16.53	5.27	9.80
50	mm	51	178	216	420	134	250
3	in.	3.00	8.00	11.13	20.27	7.08	9.80
80	mm	76	203	283	515	180	250
4	in.	4.00	9.00	12.00	23.07	8.86	9.80
100	mm	102	229	305	586	225	250
6	in.	6.00	10.51	15.87	32.20	12.20	9.80
150	mm	152	267	403	818	310	250
8	in.	8.00	11.50	16.50	40.62	15.55	9.80
200	mm	203	292	419	1032	395	250
10	in.	10.00	13.00	18.00	49.80	19.17	9.80
250	mm	254	330	457	1265	487	250
12	in.	12.00	14.01	19.76	58.74	22.16	15.75
300	mm	305	356	502	1492	563	400
14	in.	14.00	15.00	22.52	63.18	24.01	15.75
350	mm	356	381	572	1605	610	400
16	in.	16.00	15.98	24.01	71.06	27.56	20.86
400	mm	406	406	610	1805	700	530
18	in.	18.00	17.00	25.98	78.15	35.04	20.86
450	mm	457	432	660	1985	890	530
20	in.	20.00	18.00	28.00	85.24	37.60	20.86
500	mm	508	457	711	2165	955	530
22	in.	22.00	20.00	30.00	94.88	40.75	20.86
550	mm	559	508	762	2410	1035	530
24	in.	24.00	20.00	32.00	101.10	46.46	20.86
600	mm	610	508	813	2568	1180	530
26	in.	26.00	22.00	34.01	108.78	48.82	20.86
650	mm	660	559	864	2763	1240	530
28	in.	28.00	24.01	35.98	116.57	50.86	20.86
700	mm	711	610	914	2961	1292	530
30	in.	30.00	25.98	35.98	123.54	54.45	20.86
750	mm	762	660	914	3138	1383	530
32	in.	32.00	28.00	38.00	131.26	57.28	20.86
800	mm	813	711	965	3334	1455	530
34	in.	34.00	30.00	40.00	139.76	57.67	20.86
850	mm	864	760	1016	3550	1465	530
36	in.	36.00	32.00	40.00	145.98	66.30	20.86
900	mm	914	813	1016	3708	1684	530

ASME CLASS 300 FULL BORE

SLAB							
SIZE		D	RF	WE	B	C	E
2	in.	2.00	8.50	8.50	16.50	5.00	9.80
50	mm	51	216	216	420	130	250
3	in.	3.00	11.14	11.14	20.00	7.28	9.80
80	mm	76	283	283	520	185	250
4	in.	4.00	12.00	12.00	32.34	8.93	8.80
100	mm	102	305	305	593	227	225
6	in.	6.00	15.86	15.86	36.00	13.00	10.60
150	mm	152	403	403	912	330	270
8	in.	8.00	16.50	16.50	51.65	16.00	13.40
200	mm	203	419	419	1312	410	340
10	in.	10.00	18.00	18.00	53.00	18.90	20.86
250	mm	254	457	457	1350	480	530
12	in.	12.00	19.76	19.76	58.46	19.90	20.86
300	mm	305	502	502	1485	505	530
14	in.	14.00	30.00	30.00	67.00	25.00	20.86
350	mm	356	762	762	1700	634	530
16	in.	16.00	33.00	33.00	74.40	28.35	20.86
400	mm	406	838	838	1890	720	530
18	in.	18.00	36.00	36.00	79.00	31.00	20.86
450	mm	457	914	914	2000	790	530
20	in.	20.00	39.00	39.00	90.50	34.00	20.86
500	mm	508	991	991	2300	870	530
22	in.	22.00	43.00	43.00	95.00	37.00	20.86
550	mm	559	1092	1092	2410	950	530
24	in.	24.00	45.00	45.00	100.00	40.00	20.86
600	mm	610	1143	1143	2548	1005	530
26	in.	26.00	49.00	49.00	118.70	43.70	20.86
650	mm	660	1245	1245	3015	1110	530
28	in.	28.00	53.00	53.00	126.00	48.00	20.86
700	mm	711	1346	1346	3200	1220	530
30	in.	30.00	55.00	55.00	133.00	54.70	20.86
750	mm	762	1397	1397	3380	1390	530
32	in.	32.00	60.00	60.00	141.70	57.50	20.86
800	mm	813	1524	1524	3600	1460	530
34	in.	34.00	64.00	64.00	150.00	58.00	20.86
850	mm	864	1626	1626	3820	1480	530
36	in.	36.00	68.00	68.00	159.00	61.00	20.86
900	mm	914	1727	1727	4050	1550	530

The valve details on this page are the standard production range only, for other size valves or end configurations please consult the factory.
 Note OMB reserves the right to make modifications or changes to its production, without prior notice and take no responsibility for any errors in this publication.



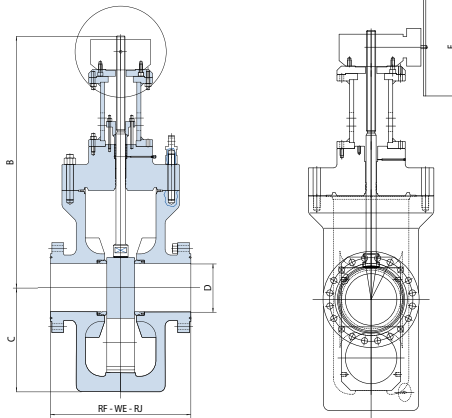

ASME CLASS 600 FULL BORE

SIZE		SLAB						
		D	RF	RJ	WE	B	C	E
2	in.	2.00	11.50	11.63	11.50	16.54	5.00	9.80
50	mm	51	292	295	292	420	130	250
3	in.	3.00	14.00	14.13	14.00	20.50	7.30	9.80
80	mm	76	356	359	356	520	185	250
4	in.	4.00	17.00	17.13	17.00	25.60	11.00	9.80
100	mm	102	432	435	432	650	280	250
6	in.	6.00	22.00	22.13	22.00	34.45	16.00	9.80
150	mm	152	559	562	559	875	409	250
8	in.	8.00	26.00	26.13	26.00	42.80	19.70	9.80
200	mm	203	660	663	660	1087	500	250
10	in.	10.00	31.00	31.13	31.00	50.80	22.00	11.80
250	mm	254	787	791	787	1290	560	300
12	in.	12.00	33.00	33.13	33.00	59.00	26.60	15.75
300	mm	305	838	841	838	1498	675	400
14	in.	14.00	35.00	35.13	35.00	66.00	28.30	15.75
350	mm	356	889	892	889	1677	720	400
16	in.	16.00	39.00	39.13	39.00	72.80	32.00	20.86
400	mm	406	991	994	991	1850	815	530
18	in.	18.00	43.00	43.13	43.00	81.00	35.00	20.86
450	mm	457	1092	1095	1092	2060	890	530
20	in.	20.00	47.00	47.25	47.00	88.40	36.60	31.50
500	mm	508	1194	1200	1194	2245	930	800
22	in.	22.00	51.00	51.38	51.00	100.40	43.00	31.50
550	mm	559	1295	1305	1295	2549	1095	800
24	in.	24.00	55.00	55.38	55.00	106.20	44.50	37.40
600	mm	610	1397	1407	1397	2697	1130	950
26	in.	26.00	57.00	57.50	57.00	109.00	46.00	37.40
650	mm	660	1448	1461	1448	2770	1170	950
28	in.	28.00	61.00	61.50	61.00	121.00	50.60	37.40
700	mm	711	1549	1562	1549	3068	1285	950
30	in.	30.00	66.30	65.50	66.30	130.00	55.70	37.40
750	mm	762	1651	1664	1651	3300	1415	950
32	in.	32.00	70.00	70.72	70.00	136.30	56.70	37.40
800	mm	813	1778	1794	1778	3462	1440	950
34	in.	34.00	76.00	76.52	76.00	146.00	60.00	37.40
850	mm	864	1930	1946	1930	3710	1525	950
36	in.	36.00	82.00	82.63	82.00	115.20	64.00	37.40
900	mm	914	2083	2099	2083	3839	1625	950

ASME CLASS 900 FULL BORE

SIZE		SLAB						
		D	RF	RJ	WE	B	C	E
2	in.	2.00	14.49	14.61	14.49	17.70	5.30	9.80
50	mm	51	368	371	368	450	135	250
3	in.	3.00	15.00	15.12	15.00	21.20	7.30	9.80
80	mm	76	381	384	381	538	185	250
4	in.	4.00	17.99	18.11	17.99	26.60	9.25	9.80
100	mm	102	457	460	457	675	235	250
6	in.	6.00	24.02	24.13	24.02	38.60	13.40	15.25
150	mm	152	610	613	610	980	340	400
8	in.	8.00	29.02	29.13	29.02	48.00	17.00	20.86
200	mm	203	737	740	737	1220	435	530
10	in.	10.00	32.99	33.11	32.99	52.40	19.30	20.86
250	mm	254	838	841	838	1330	490	530
12	in.	12.00	37.99	38.11	37.99	60.00	2.80	20.86
300	mm	305	965	968	965	1525	580	530
14	in.	14.00	40.51	40.87	40.51	63.80	23.80	20.86
350	mm	356	1029	1038	1029	1620	605	530
16	in.	16.00	44.49	44.88	44.49	69.00	28.60	29.52
400	mm	406	1130	1140	1130	1755	726	750
18	in.	18.00	47.99	48.50	47.99	93.60	30.00	29.52
450	mm	457	1219	1232	1219	2377	760	750
20	in.	20.00	52.01	52.48	52.01	190.30	31.50	29.52
500	mm	508	1321	1334	1321	2776	800	750
24	in.	24.00	60.98	61.73	60.98	130.30	41.30	47.25
600	mm	610	1549	1568	1549	3310	1050	1200
28	in.	28.00	70.00	71.00	70.00	154.00	45.30	47.25
700	mm	711	1778	1800	1778	3913	1150	1200
30	in.	30.00	74.02	74.88	74.02	164.40	52.00	47.25
750	mm	762	1880	1902	1880	4175	1320	1200
32	in.	32.00	80.00	80.87	80.00	177.80	51.50	47.25
800	mm	813	2032	2054	2032	4517	1307	1200
34	in.	34.00	85.00	86.14	85.00	187.40	54.40	47.25
850	mm	864	2159	2188	2159	4760	1382	1200
36	in.	36.00	90.00	91.14	90.00	196.50	61.80	47.25
900	mm	914	2286	2315	2286	4990	1570	1200

The valve details on this page are the standard production range only, for other size valves or end configurations please consult the factory.
 Note OMB reserves the right to make modifications or changes to its production, without prior notice and take no responsibility for any errors in this publication.



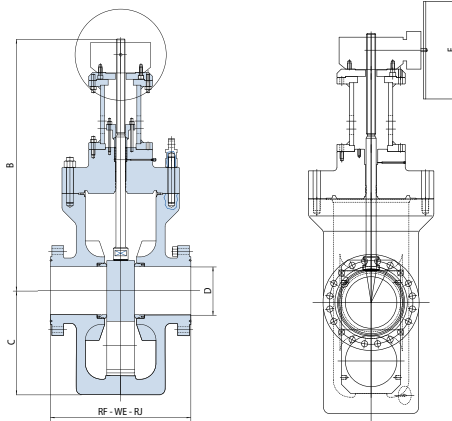

ASME CLASS 1500 FULL BORE

SIZE		SLAB						
		D	RF	RJ	WE	B	C	E
2	in.	2.00	14.49	14.61	14.49	21.00	5.50	9.80
50	mm	51	368	371	368	510	140	250
3	in.	3.00	18.50	18.62	18.50	26.50	7.70	9.80
80	mm	76	470	473	470	675	195	250
4	in.	4.00	21.50	21.61	21.50	29.30	10.45	20.47
100	mm	102	546	549	546	745	265	520
6	in.	6.00	27.76	27.99	27.76	42.50	12.85	26.00
150	mm	152	705	711	705	1080	326	660
8	in.	8.00	32.76	33.11	32.76	52.00	16.35	26.00
200	mm	203	832	841	832	1320	415	660
10	in.	10.00	39.02	39.37	39.02	58.50	18.25	29.52
250	mm	254	991	1000	991	1485	464	750
12	in.	12.00	44.49	44.61	44.49	63.60	21.65	32.28
300	mm	305	1130	1146	1130	1615	550	820
14	in.	14.00	49.49	50.24	49.49	72.00	24.00	32.28
350	mm	356	1257	1276	1257	1820	593	820
16	in.	16.00	54.49	55.35	54.49	77.50	27.50	37.40
400	mm	406	1384	1407	1384	1965	700	950
18	in.	18.00	60.51	61.38	60.51	98.00	30.00	37.40
450	mm	457	1537	1559	1537	2490	765	950
20	in.	20.00	65.51	66.38	66.51	116.15	32.00	47.25
500	mm	508	1664	1686	1664	2950	815	1200
24	in.	24.00	76.00	81.54	76.00	140.00	41.50	47.25
600	mm	610	1943	1972	1943	3550	1050	1200

ASME CLASS 2500 FULL BORE

SIZE		SLAB						
		D	RF	RJ	WE	B	C	E
2	in.	1.65	17.76	17.87	17.76	12.08	8.00	9.80
50	mm	42	451	454	451	307	203	250
3	in.	2.44	22.76	22.99	22.76	15.48	10.30	9.80
80	mm	62	578	584	578	339	262	250
4	in.	3.43	26.50	26.89	26.50	18.02	12.00	20.47
100	mm	87	673	683	673	458	305	520
6	in.	5.16	35.98	36.50	35.98	24.50	16.30	26.00
150	mm	131	914	927	914	622	414	660
8	in.	7.05	40.24	40.87	40.24	27.50	18.20	26.00
200	mm	179	1022	1038	1022	698	462	660
10	in.	8.78	50.00	50.87	50.00	34.00	22.65	29.52
250	mm	223	1270	1292	1270	864	575	750
12	in.	10.43	55.98	56.89	55.98	38.00	25.36	32.28
300	mm	265	1422	1445	1422	965	644	820

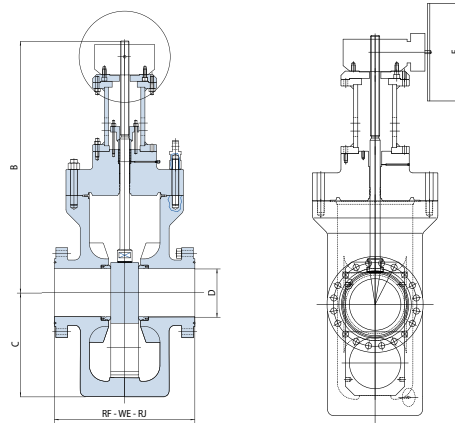

API CLASS 5000 FULL BORE

SLAB						
SIZE		D	RJ	B	C	E
2 1/16	in.	2.06	16.60	18.70	6.50	20.00
52	mm	52	371	475	165	500
2 9/16	in.	-	-	-	-	-
65	mm	-	-	-	-	-
3 1/8	in.	3.12	18.60	22.84	10.45	24.00
78	mm	78	473	580	265	600
4 1/16	in.	4.06	21.70	27.50	12.80	24.00
103	mm	103	549	700	325	600
5 1/8	in.	5.12	28.70	42.50	12.85	24.00
130	mm	130	727	1080	326	600
7 1/16	in.	-	-	-	-	-
200	mm	-	-	-	-	-
9	in.	-	-	-	-	-
228	mm	-	-	-	-	-
11	in.	-	-	-	-	-
274	mm	-	-	-	-	-

API CLASS 10000 FULL BORE

SLAB						
SIZE		D	RJ	B	C	E
1 13/16	in.	2.06	18.20	16.5	5.50	16.00
46	mm	46	463	421	140	400
2 1/16	in.	3.12	20.50	18.00	6.50	20.00
52	mm	53	521	460	165	500
3 1/4	in.	4.06	24.40	23.00	10.50	24.00
78	mm	78	619	580	265	600
4 1/16	in.	4.10	26.40	27.50	12.80	24.00
103	mm	104	670	700	325	600
7 1/16	in.	7.08	35.00	41.30	17.70	24.00
179	mm	180	889	1050	450	600
9	in.	9.00	43.00	43.70	22.05	32
228	mm	229	1092	1110	560	800
11	in.	11.02	47.00	62.80	26.80	32
279	mm	280	1194	1595	680	800



OMB manufactures both API 6A and 6D compliant valves with our innovative design and proof testing the OMB Split gate valve offers true double barrier sealing with mechanically energized independent seats, thus providing a compact double isolation in a minimal effective design. The OMB design is used where additional safety barriers are required in your system with reduced space and weight being necessary.

A key feature of our design is the reduced frictional forces and hence the reduced torque requirements for sealing, this coupled with our own actuators provide a more effective compact design for all off shore applications.

Tungsten carbide Coating (TCC) of the gate and seats along with our tertiary stem sealing provides a high standard of sealing capability.

The innovative tertiary stem sealing provided as standard within the OMB valve, coupled with the metal to metal back seat in the actuated design ensure no fugitive emissions.

Static body to bonnet seals of metal to metal design ensure that all body joints are stronger than that of the surrounding pipe work.

The full bore design offers trouble free operation for the duration of the valve life.

CONSTRUCTION

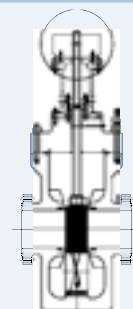

KEY FEATURES ARE:

- ✓ FULL BORE.
- ✓ BI DIRECTIONAL SEALING.
- ✓ DOUBLE BLOCK CAPABILITIES.
- ✓ BUBBLE TIGHT SEALING.
- ✓ METAL TO METAL SEALING



CLASS DIAMETER	CLASS 150 FB	CLASS 300 FB	CLASS 600 FB	CLASS 900 FB	CLASS 1500 FB	CLASS 2500 FB
1/2"						
3/4"						
1"						
1 1/2"						
2"	●	●	●	●	●	●
3"	●	●	●	●	●	●
4"	●	●	●	●	●	●
6"	●	●	●	●	●	●
8"	●	●	●	●	●	●
10"	●	●	●	●	●	●
12"	●	●	●	●	●	●
14"	●	●	●	●	●	
16"	●	●	●	●	●	
18"	●	●	●	●	●	
20"	●	●	●	●	●	
22"	●	●	●	●	●	
24"	●	●	●	●	●	
26"	●	●	●	●	●	
28"	●	●	●	●	●	
30"	●	●	●	●	●	
32"	●	●	●	●	●	
34"	●	●	●	●	●	
36"	●	●	●	●	●	

Applicable Standards

API 6D LICIENCE No 6D-0286

API 6A LICIENCE No 6A-0778

API Spec. Q1

API 6D (EN ISO 14313) Pipeline Transportation Systems-Pipeline Valves.

API 598 (Inspection Testing)

API 14D Sand Slurry (Annex I API 6A)

ASME B16.34

(Vales-Flanged, Threaded and Welding end)

ASME B16.5 (Pipe Flanges and Flanged Fittings)

ASME B16.10 (Face to Face Dimensions)

ASME B16.25 (Butt weld ends)

ASME

(Boiler and Pressure vessel Code II, V, VIII, X)

ASME B31.8

Gas transmission and Distribution piping systems.

ASME B31.4

Liquid Petroleum transmission piping systems.

BS EN ISO 10497-Fire Testing.

BS EN 12266 – 1/2. (Testing Of Valves)

BS EN ISO 4406 (Hydraulic Fluid Cleanliness)

BS EN 10204 (Metallic Products Inspection Documents)

EU Pressure Equipment Directive.

EN ISO 9001:2008

ISO 5208 (industrial valves pressure testing)

NACE MR0175 / ISO 15156

(Sulphide Stress Cracking Resistant Materials for offshore applications)

NORSOK L-001 Piping and Valves.

NORSOK M-630 - Material Data Sheets for Piping.

NORSOK M-650 - Qualification of Manufacturers of special materials



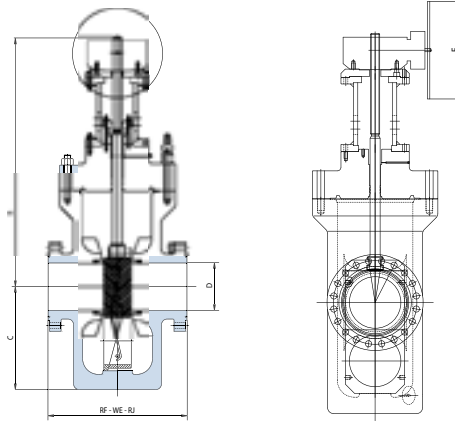

ASME CLASS 150 FULL BORE

SPLIT							
SIZE		D	RF	WE	B	C	E
2	in.	2.00	7.00	8.50	16.53	5.27	9.80
50	mm	51	178	216	420	134	250
3	in.	3.00	8.00	11.13	20.27	7.08	9.80
80	mm	76	203	283	515	180	250
4	in.	4.00	9.00	12.00	23.07	8.86	9.80
100	mm	102	229	305	586	225	250
6	in.	6.00	10.51	15.87	32.20	12.20	9.80
150	mm	152	267	403	818	310	250
8	in.	8.00	11.50	16.50	40.62	15.55	9.80
200	mm	203	292	419	1032	395	250
10	in.	10.00	13.00	18.00	49.80	19.17	9.80
250	mm	254	330	457	1265	487	250
12	in.	12.00	14.01	19.76	58.74	22.16	15.75
300	mm	305	356	502	1492	563	400
14	in.	14.00	15.00	22.52	63.18	24.01	15.75
350	mm	356	381	572	1605	610	400
16	in.	16.00	15.98	24.01	71.06	27.56	20.86
400	mm	406	406	610	1805	700	530
18	in.	18.00	17.00	25.98	78.15	35.04	20.86
450	mm	457	432	660	1985	890	530
20	in.	20.00	18.00	28.00	85.24	37.60	20.86
500	mm	508	457	711	2165	955	530
22	in.	22.00	20.00	30.00	94.88	40.75	20.86
550	mm	559	508	762	2410	1035	530
24	in.	24.00	20.00	32.00	101.10	46.46	20.86
600	mm	610	508	813	2568	1180	530
26	in.	26.00	22.00	34.01	108.78	48.82	20.86
650	mm	660	559	864	2763	1240	530
28	in.	28.00	24.01	35.98	116.57	50.86	20.86
700	mm	711	610	914	2961	1292	530
30	in.	30.00	25.98	35.98	123.54	54.45	20.86
750	mm	762	660	914	3138	1383	530
32	in.	32.00	28.00	38.00	131.26	57.28	20.86
800	mm	813	711	965	3334	1455	530
34	in.	34.00	30.00	40.00	139.76	57.67	20.86
850	mm	864	760	1016	3550	1465	530
36	in.	36.00	32.00	40.00	145.98	66.30	20.86
900	mm	914	813	1016	3708	1684	530

ASME CLASS 300 FULL BORE

SPLIT							
SIZE		D	RF	WE	B	C	E
2	in.	2.00	8.50	8.50	16.50	5.00	9.80
50	mm	51	216	216	420	130	250
3	in.	3.00	11.14	11.14	20.00	7.28	9.80
80	mm	76	283	283	520	185	250
4	in.	4.00	12.00	12.00	32.34	8.93	8.80
100	mm	102	305	305	593	227	225
6	in.	6.00	15.86	15.86	36.00	13.00	10.60
150	mm	152	403	403	912	330	270
8	in.	8.00	16.50	16.50	51.65	16.00	13.40
200	mm	203	419	419	1312	410	340
10	in.	10.00	18.00	18.00	53.00	18.90	20.86
250	mm	254	457	457	1350	480	530
12	in.	12.00	19.76	19.76	58.46	19.90	20.86
300	mm	305	502	502	1485	505	530
14	in.	14.00	30.00	30.00	67.00	25.00	20.86
350	mm	356	762	762	1700	634	530
16	in.	16.00	33.00	33.00	74.40	28.35	20.86
400	mm	406	838	838	1890	720	530
18	in.	18.00	36.00	36.00	79.00	31.00	20.86
450	mm	457	914	914	2000	790	530
20	in.	20.00	39.00	39.00	90.50	34.00	20.86
500	mm	508	991	991	2300	870	530
22	in.	22.00	43.00	43.00	95.00	37.00	20.86
550	mm	559	1092	1092	2410	950	530
24	in.	24.00	45.00	45.00	100.00	40.00	20.86
600	mm	610	1143	1143	2548	1005	530
26	in.	26.00	49.00	49.00	118.70	43.70	20.86
650	mm	660	1245	1245	3015	1110	530
28	in.	28.00	53.00	53.00	126.00	48.00	20.86
700	mm	711	1346	1346	3200	1220	530
30	in.	30.00	55.00	55.00	133.00	54.70	20.86
750	mm	762	1397	1397	3380	1390	530
32	in.	32.00	60.00	60.00	141.70	57.50	20.86
800	mm	813	1524	1524	3600	1460	530
34	in.	34.00	64.00	64.00	150.00	58.00	20.86
850	mm	864	1626	1626	3820	1480	530
36	in.	36.00	68.00	68.00	159.00	61.00	20.86
900	mm	914	1727	1727	4050	1550	530

The valve details on this page are the standard production range only, for other size valves or end configurations please consult the factory.

Note OMB reserves the right to make modifications or changes to its production, without prior notice and take no responsibility for any errors in this publication.



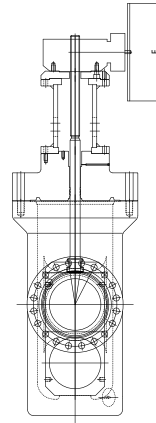
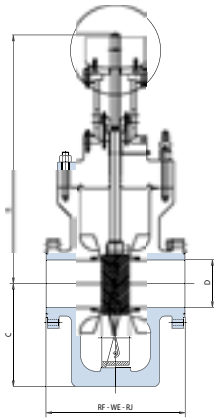

ASME CLASS 600 FULL BORE

SIZE		SPLIT						
		D	RF	RJ	WE	B	C	E
2	in.	2.00	11.50	11.63	11.50	16.54	5.00	9.80
50	mm	51	292	295	292	420	130	250
3	in.	3.00	14.00	14.13	14.00	20.50	7.30	9.80
80	mm	76	356	359	356	520	185	250
4	in.	4.00	17.00	17.13	17.00	25.60	11.00	9.80
100	mm	102	432	435	432	650	280	250
6	in.	6.00	22.00	22.13	22.00	34.45	16.00	9.80
150	mm	152	559	562	559	875	409	250
8	in.	8.00	26.00	26.13	26.00	42.80	19.70	9.80
200	mm	203	660	663	660	1087	500	250
10	in.	10.00	31.00	31.13	31.00	50.80	22.00	11.80
250	mm	254	787	791	787	1290	560	300
12	in.	12.00	33.00	33.13	33.00	59.00	26.60	15.75
300	mm	305	838	841	838	1498	675	400
14	in.	14.00	35.00	35.13	35.00	66.00	28.30	15.75
350	mm	356	889	892	889	1677	720	400
16	in.	16.00	39.00	39.13	39.00	72.80	32.00	20.86
400	mm	406	991	994	991	1850	815	530
18	in.	18.00	43.00	43.13	43.00	81.00	35.00	20.86
450	mm	457	1092	1095	1092	2060	890	530
20	in.	20.00	47.00	47.25	47.00	88.40	36.60	31.50
500	mm	508	1194	1200	1194	2245	930	800
22	in.	22.00	51.00	51.38	51.00	100.40	43.00	31.50
550	mm	559	1295	1305	1295	2549	1095	800
24	in.	24.00	55.00	55.38	55.00	106.20	44.50	37.40
600	mm	610	1397	1407	1397	2697	1130	950
26	in.	26.00	57.00	57.50	57.00	109.00	46.00	37.40
650	mm	660	1448	1461	1448	2770	1170	950
28	in.	28.00	61.00	61.50	61.00	121.00	50.60	37.40
700	mm	711	1549	1562	1549	3068	1285	950
30	in.	30.00	66.30	65.50	66.30	130.00	55.70	37.40
750	mm	762	1651	1664	1651	3300	1415	950
32	in.	32.00	70.00	70.72	70.00	136.30	56.70	37.40
800	mm	813	1778	1794	1778	3462	1440	950
34	in.	34.00	76.00	76.52	76.00	146.00	60.00	37.40
850	mm	864	1930	1946	1930	3710	1525	950
36	in.	36.00	82.00	82.63	82.00	115.20	64.00	37.40
900	mm	914	2083	2099	2083	3839	1625	950

ASME CLASS 900 FULL BORE

SIZE		SPLIT						
		D	RF	RJ	WE	B	C	E
2	in.	2.00	14.49	14.61	14.49	17.70	5.30	9.80
50	mm	51	368	371	368	450	135	250
3	in.	3.00	15.00	15.12	15.00	21.20	7.30	9.80
80	mm	76	381	384	381	538	185	250
4	in.	4.00	17.99	18.11	17.99	26.60	9.25	9.80
100	mm	102	457	460	457	675	235	250
6	in.	6.00	24.02	24.13	24.02	38.60	13.40	15.25
150	mm	152	610	613	610	980	340	400
8	in.	8.00	29.02	29.13	29.02	48.00	17.00	20.86
200	mm	203	737	740	737	1220	435	530
10	in.	10.00	32.99	33.11	32.99	52.40	19.30	20.86
250	mm	254	838	841	838	1330	490	530
12	in.	12.00	37.99	38.11	37.99	60.00	2.80	20.86
300	mm	305	965	968	965	1525	580	530
14	in.	14.00	40.51	40.87	40.51	63.80	23.80	20.86
350	mm	356	1029	1038	1029	1620	605	530
16	in.	16.00	44.49	44.88	44.49	69.00	28.60	29.52
400	mm	406	1130	1140	1130	1755	726	750
18	in.	18.00	47.99	48.50	47.99	93.60	30.00	29.52
450	mm	457	1219	1232	1219	2377	760	750
20	in.	20.00	52.01	52.48	52.01	190.30	31.50	29.52
500	mm	508	1321	1334	1321	2776	800	750
24	in.	24.00	60.98	61.73	60.98	130.30	41.30	47.25
600	mm	610	1549	1568	1549	3310	1050	1200
28	in.	28.00	70.00	71.00	70.00	154.00	45.30	47.25
700	mm	711	1778	1800	1778	3913	1150	1200
30	in.	30.00	74.02	74.88	74.02	164.40	52.00	47.25
750	mm	762	1880	1902	1880	4175	1320	1200
32	in.	32.00	80.00	80.87	80.00	177.80	51.50	47.25
800	mm	813	2032	2054	2032	4517	1307	1200
34	in.	34.00	85.00	86.14	85.00	187.40	54.40	47.25
850	mm	864	2159	2188	2159	4760	1382	1200
36	in.	36.00	90.00	91.14	90.00	196.50	61.80	47.25
900	mm	914	2286	2315	2286	4990	1570	1200

The valve details on this page are the standard production range only, for other size valves or end configurations please consult the factory.
 Note OMB reserves the right to make modifications or changes to its production, without prior notice and take no responsibility for any errors in this publication.



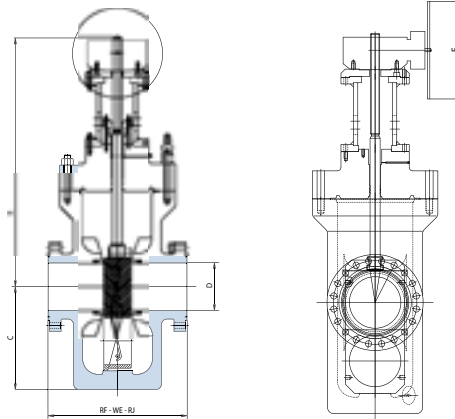

ASME CLASS 1500 FULL BORE

SIZE		SPLIT						
		D	RF	RJ	WE	B	C	E
2	in.	2.00	14.49	14.61	14.49	21.00	5.50	9.80
50	mm	51	368	371	368	510	140	250
3	in.	3.00	18.50	18.62	18.50	26.50	7.70	9.80
80	mm	76	470	473	470	675	195	250
4	in.	4.00	21.50	21.61	21.50	29.30	10.45	20.47
100	mm	102	546	549	546	745	265	520
6	in.	6.00	27.76	27.99	27.76	42.50	12.85	26.00
150	mm	152	705	711	705	1080	326	660
8	in.	8.00	32.76	33.11	32.76	52.00	16.35	26.00
200	mm	203	832	841	832	1320	415	660
10	in.	10.00	39.02	39.37	39.02	58.50	18.25	29.52
250	mm	254	991	1000	991	1485	464	750
12	in.	12.00	44.49	44.61	44.49	63.60	21.65	32.28
300	mm	305	1130	1146	1130	1615	550	820
14	in.	14.00	49.49	50.24	49.49	72.00	24.00	32.28
350	mm	356	1257	1276	1257	1820	593	820
16	in.	16.00	54.49	55.35	54.49	77.50	27.50	37.40
400	mm	406	1384	1407	1384	1965	700	950
18	in.	18.00	60.51	61.38	60.51	98.00	30.00	37.40
450	mm	457	1537	1559	1537	2490	765	950
20	in.	20.00	65.51	66.38	66.51	116.15	32.00	47.25
500	mm	508	1664	1686	1664	2950	815	1200
24	in.	24.00	76.00	81.54	76.00	140.00	41.50	47.25
600	mm	610	1943	1972	1943	3550	1050	1200

ASME CLASS 2500 FULL BORE

SIZE		SPLIT						
		D	RF	RJ	WE	B	C	E
2	in.	1.65	17.76	17.87	17.76	12.08	8.00	9.80
50	mm	42	451	454	451	307	203	250
3	in.	2.44	22.76	22.99	22.76	15.48	10.30	9.80
80	mm	62	578	584	578	339	262	250
4	in.	3.43	26.50	26.89	26.50	18.02	12.00	20.47
100	mm	87	673	683	673	458	305	520
6	in.	5.16	35.98	36.50	35.98	24.50	16.30	26.00
150	mm	131	914	927	914	622	414	660
8	in.	7.05	40.24	40.87	40.24	27.50	18.20	26.00
200	mm	179	1022	1038	1022	698	462	660
10	in.	8.78	50.00	50.87	50.00	34.00	22.65	29.52
250	mm	223	1270	1292	1270	864	575	750
12	in.	10.43	55.98	56.89	55.98	38.00	25.36	32.28
300	mm	265	1422	1445	1422	965	644	820

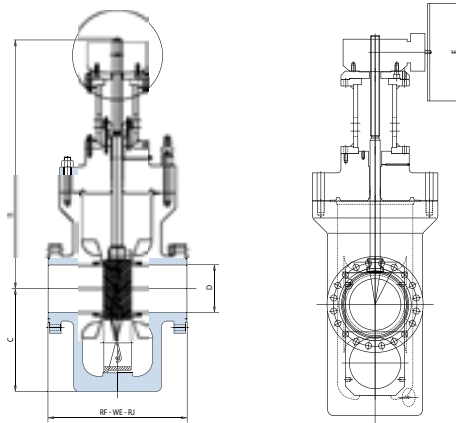

API CLASS 5000 FULL BORE

SPLIT						
SIZE		D	RJ	B	C	E
2 1/16	in.	2.06	16.60	18.70	6.50	20.00
52	mm	52	371	475	165	500
2 9/16	in.	-	-	-	-	-
65	mm	-	-	-	-	-
3 1/8	in.	3.12	18.60	22.84	10.45	24.00
78	mm	78	473	580	265	600
4 1/16	in.	4.06	21.70	27.50	12.80	24.00
103	mm	103	549	700	325	600
5 1/8	in.	5.12	28.70	42.50	12.85	24.00
130	mm	130	727	1080	326	600
7 1/16	in.	-	-	-	-	-
200	mm	-	-	-	-	-
9	in.	-	-	-	-	-
228	mm	-	-	-	-	-
11	in.	-	-	-	-	-
274	mm	-	-	-	-	-

API CLASS 10000 FULL BORE

SPLIT						
SIZE		D	RJ	B	C	E
1 13/16	in.	2.06	18.20	16.5	5.50	16.00
46	mm	46	463	421	140	400
2 1/16	in.	3.12	20.50	18.00	6.50	20.00
52	mm	53	521	460	165	500
3 1/4	in.	4.06	24.40	23.00	10.50	24.00
78	mm	78	619	580	265	600
4 1/16	in.	4.10	26.40	27.50	12.80	24.00
103	mm	104	670	700	325	600
7 1/16	in.	7.08	35.00	41.30	17.70	24.00
179	mm	180	889	1050	450	600
9	in.	9.00	43.00	43.70	22.05	32
228	mm	229	1092	1110	560	800
11	in.	11.02	47.00	62.80	26.80	32
279	mm	280	1194	1595	680	800



OMB Swing Check Valves (SCV) are designed as full bore, with no body penetrations for additional security. Our SCV are designed for the positive prevention of back flow in gas or liquid processes.

Fully piggable designs are available and ensure that the seats are well protected from the pig when passing through the valve cavity during operation.

Lock Open facility can be added where the clapper is held out of the flow area, allowing for reverse flow through the valve.

OMB utilizes PTFE Lip seal plus multi pack chevron PTFE stems seals to provide a secure multi barrier to the atmosphere when manual override is required.

Standard OMB Seats are hard faced metal to metal welded Satellite providing high resistance to erosion, soft seated options are be offered where both low

pressure and high pressure sealing is required.

Body joint seals are Spiral Wound SS316 & Graphite or metal to metal 718.

Non slam facility is also available where excess changes in flow are predicted.

Body cavity plugs are supplied for the purpose of providing flushing, drain and vent facilities with high integrity sealing capabilities if required.

CONSTRUCTION

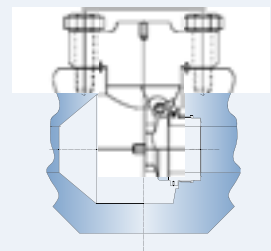

KEY FEATURES ARE:

- ✓ FULL BORE, PIGGABLE
- ✓ NON-SLAM.
- ✓ LOCK OPEN.
- ✓ BUBBLE TIGHT SEALING.
- ✓ METAL TO METAL SEALING



CLASS DIAMETER	CLASS 150 FB	CLASS 300 FB	CLASS 600 FB	CLASS 900 FB	CLASS 1500 FB	CLASS 2500 FB
1/2"						
3/4"						
1"						
1 1/2"						
2"	●	●	●	●	●	●
3"	●	●	●	●	●	●
4"	●	●	●	●	●	●
6"	●	●	●	●	●	●
8"	●	●	●	●	●	●
10"	●	●	●	●	●	●
12"	●	●	●	●	●	●
14"	●	●	●	●	●	
16"	●	●	●	●	●	
18"	●	●	●	●	●	
20"	●	●	●	●	●	
22"	●	●	●	●	●	
24"	●	●	●	●	●	
26"			●			
28"			●			
30"			●			

Applicable Standards

API 6D LICIENCE No 6D-0286

API 6A LICIENCE No 6A-0778

API Spec. Q1

API 6D (EN ISO 14313)
Pipeline Transportation Systems-Pipeline Valves.

API 598 (Inspection Testing)

API 14D Sand Slurry (Annex I API 6A)

ASME B16.34

(Valves-Flanged, Threaded and Welding end)

ASME B16.5 (Pipe Flanges and Flanged Fittings)

ASME B16.10 (Face to Face Dimensions)

ASME B16.25 (Butt weld ends)

ASME

(Boiler and Pressure vessel Code II, V, VIII, X)

ASME B31.8 - Gas transmission and Distribution piping systems.

ASME B31.4 - Liquid Petroleum transmission piping systems.

BS EN ISO 10497-Fire Testing.

BS EN 12266 – 1/2. (Testing Of Valves)

BS EN ISO 4406 (Hydraulic Fluid Cleanliness)

BS EN 10204

(Metallic Products Inspection Documents)

EU Pressure Equipment Directive.

EN ISO 9001:2008

ISO 5208 (industrial valves pressure testing)

NACE MR0175 / ISO 15156

(Sulphide Stress Cracking Resistant Materials for offshore applications)

NORSOK L-001-Piping and Valves.

NORSOK M-630 - Material Data Sheets for Piping.

NORSOK M-650 - Qualification of Manufacturers of special materials.

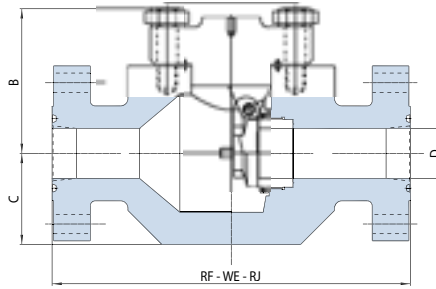

ASME CLASS 150 FULL BORE

SIZE		SWING				
SIZE		D	RF	WE	B	C
2	in.	2.00	7.00	8.50	4.50	3.30
50	mm	51	178	216	115	77
3	in.	3.00	8.00	11.13	7.00	3.50
80	mm	76	203	283	178	89
4	in.	4.00	9.00	12.00	7.50	4.50
100	mm	102	229	305	191	115
6	in.	6.00	15.50	18.00	8.50	5.50
150	mm	152	394	457	216	140
8	in.	8.00	18.00	20.50	10.50	7.00
200	mm	203	457	521	261	178
10	in.	10.00	21.00	22.00	12.00	8.50
250	mm	254	533	559	305	216
12	in.	12.00	24.00	25.00	15.50	9.50
300	mm	305	610	635	394	242
14	in.	14.00	27.00	30.00	19.00	10.00
350	mm	356	686	762	473	237
16	in.	16.00	30.00	33.00	23.00	11.50
400	mm	406	762	838	579	290
18	in.	18.00	34.00	36.00	24.00	12.00
450	mm	457	864	914	588	294
20	in.	20.00	36.00	39.00	24.00	12.00
500	mm	508	914	991	588	294
22	in.	22.00	40.00	43.00	26.00	13.00
550	mm	559	991	1092	641	320
24	in.	24.00	42.00	45.00	31.00	16.00
600	mm	610	1067	1143	778	389

ASME CLASS 300 FULL BORE

SIZE		SWING				
SIZE		D	RF	WE	B	C
2	in.	2.00	8.50	8.50	4.50	3.00
50	mm	51	216	216	115	77
3	in.	3.00	11.10	11.10	6.50	4.50
80	mm	76	283	283	166	115
4	in.	4.00	12.00	12.00	7.75	5.00
100	mm	102	305	305	197	127
6	in.	6.00	15.90	18.00	9.25	6.00
150	mm	152	457	457	235	153
8	in.	8.00	19.80	20.50	11.50	7.50
200	mm	203	502	521	293	191
10	in.	10.00	22.40	22.00	14.50	8.00
250	mm	254	568	559	369	204
12	in.	12.00	25.50	25.00	16.75	10.00
300	mm	305	648	635	426	252
14	in.	14.00	30.00	30.00	20.00	10.00
350	mm	356	762	762	504	252
16	in.	16.00	33.00	33.00	21.00	11.00
400	mm	406	838	838	519	260
18	in.	18.00	36.00	36.00	24.00	12.00
450	mm	457	914	914	588	294
20	in.	20.00	39.00	39.00	25.00	13.00
500	mm	508	991	991	610	305
22	in.	22.00	43.00	43.00	28.00	14.00
550	mm	559	1092	1092	708	354
24	in.	24.00	45.00	45.00	32.00	16.00
600	mm	610	1143	1143	808	404

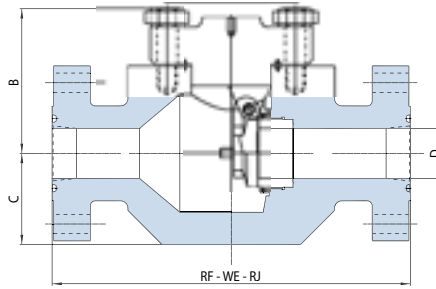

ASME CLASS 600 FULL BORE

SIZE		SWING					
SIZE		D	RF	RJ	WE	B	C
2	in.	2.00	11.50	11.63	11.50	6.25	3.00
50	mm	51	292	295	292	159	77
3	in.	3.00	14.00	14.13	14.00	8.00	4.00
80	mm	76	356	359	356	204	102
4	in.	4.00	17.00	17.13	17.00	8.75	5.00
100	mm	102	432	435	432	223	127
6	in.	6.00	22.00	22.13	22.00	10.25	7.00
150	mm	152	559	562	559	261	178
8	in.	8.00	26.00	26.13	26.00	12.50	8.00
200	mm	203	660	664	660	318	204
10	in.	10.00	31.00	31.13	31.00	15.00	10.00
250	mm	254	787	791	787	381	254
12	in.	12.00	33.00	33.13	33.00	17.00	11.00
300	mm	305	838	841	838	432	280
14	in.	14.00	35.00	35.13	35.00	22.00	11.00
350	mm	356	889	892	889	534	280
16	in.	16.00	39.00	39.13	39.00	24.00	12.00
400	mm	406	991	994	991	545	298
18	in.	18.00	43.00	43.13	43.00	26.00	13.00
450	mm	457	1092	1095	1092	656	328
20	in.	20.00	47.00	47.25	47.00	29.00	15.00
500	mm	508	1194	1200	1194	717	359
22	in.	22.00	51.00	51.38	51.00	31.00	16.00
550	mm	559	1295	1305	1295	778	389
24	in.	24.00	55.00	55.38	55.00	34.00	17.00
600	mm	610	1397	1407	1397	839	420

ASME CLASS 900 FULL BORE

SIZE		SWING					
SIZE		D	RF	RJ	WE	B	C
2	in.	2.00	14.49	14.61	14.49	6.50	4.00
50	mm	51	368	371	368	166	162
3	in.	3.00	15.00	15.12	15.00	7.25	4.50
80	mm	76	381	384	381	185	115
4	in.	4.00	17.99	18.11	17.99	8.25	5.50
100	mm	102	457	460	457	210	140
6	in.	6.00	24.02	24.13	24.02	11.25	7.50
150	mm	152	610	613	610	286	191
8	in.	8.00	29.02	29.13	29.02	14.50	9.00
200	mm	203	737	740	737	367	229
10	in.	10.00	32.99	33.11	32.99	16.50	10.50
250	mm	254	838	841	838	420	267
12	in.	12.00	37.99	38.11	37.99	18.00	12.00
300	mm	305	965	968	965	458	305
14	in.	14.00	40.51	40.87	40.51	25.00	13.00
350	mm	356	1029	1038	1029	618	309
16	in.	16.00	44.49	44.88	44.49	28.00	14.00
400	mm	406	1130	1140	1130	678	339
18	in.	18.00	47.99	48.50	47.99	30.00	15.00
450	mm	457	1219	1232	1219	732	366
20	in.	20.00	52.01	52.48	52.01	32.00	16.00
500	mm	508	1321	1334	1321	792	396
24	in.	24.00	60.98	61.73	60.98	37.00	19.00
600	mm	610	1549	1568	1549	930	465

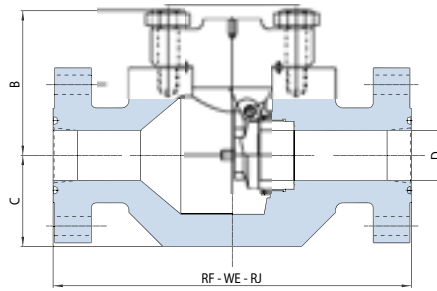

ASME CLASS 1500 FULL BORE

SWING							
SIZE		D	RF	RJ	WE	B	C
2	in.	2.00	14.49	14.61	14.49	6.25	4.00
50	mm	51	368	371	368	159	102
3	in.	3.00	18.50	18.62	18.50	10.75	5.00
80	mm	76	470	473	470	274	122
4	in.	4.00	21.50	21.61	21.50	10.75	6.00
100	mm	102	546	549	546	274	153
6	in.	6.00	27.76	27.99	27.76	13.75	7.00
150	mm	152	705	711	705	350	178
8	in.	8.00	32.76	33.11	32.76	20.00	10.00
200	mm	203	832	841	832	502	251
10	in.	10.00	39.02	39.37	39.02	24.00	12.00
250	mm	254	991	1000	991	594	297
12	in.	12.00	44.49	44.61	44.49	30.00	15.00
300	mm	305	1130	1146	1130	756	378
14	in.	14.00	49.49	50.24	49.49	30.00	15.00
350	mm	356	1257	1276	1257	756	378
16	in.	16.00	54.49	55.35	54.49	34.00	17.00
400	mm	406	1384	1407	1384	832	416
18	in.	18.00	60.51	61.38	60.51	37.00	19.00
450	mm	457	1537	1559	1537	923	462
20	in.	20.00	65.51	66.38	65.51	40.00	20.00
500	mm	508	1664	1686	1664	999	500
24	in.	24.00	80.43	81.54	80.43	49.00	25.00
600	mm	610	2043	1972	2043	1226	613

ASME CLASS 2500 FULL BORE

SWING							
SIZE		D	RF	RJ	WE	B	C
2	in.	2.00	17.76	17.87	17.76	11.00	6.00
50	mm	51	451	454	451	271	136
3	in.	3.00	22.76	22.99	22.76	14.00	7.00
80	mm	76	578	584	578	348	174
4	in.	4.00	26.50	26.89	26.50	16.00	8.00
100	mm	102	673	683	673	404	202
6	in.	6.00	35.98	36.50	35.98	22.00	11.00
150	mm	152	914	927	914	549	275
8	in.	8.00	40.24	40.87	40.24	25.00	13.00
200	mm	203	1022	1038	1022	614	307
10	in.	10.00	50.00	50.87	50.00	30.00	15.00
250	mm	254	1270	1292	1270	762	381
12	in.	12.00	55.98	56.89	55.98	34.00	12.00
300	mm	305	1422	1445	1422	854	427

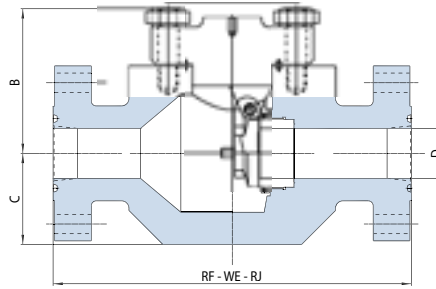

API CLASS 3000 FULL BORE

SWING					
SIZE		D	RJ	B	C
2 1/16	in.	2.06	14.61	4.33	8.28
50	mm	52.4	371	110	210
3 1/8	in.	3.12	17.13	5.00	10.13
80	mm	79.3	435	150	257
4 1/16	in.	4.06	20.12	6.69	11.43
100	mm	103.2	511	170	290
5 1/8	in.	5.12	24.13	10.16	11.97
125	mm	130	613	258	304
7 1/16	in.	7.06	28.11	13.39	12.72
200	mm	179.4	714	340	323

API CLASS 5000 FULL BORE

SWING					
SIZE		D	RJ	B	C
2 1/16	in.	2.06	14.61	4.33	8.28
50	mm	52.4	371	110	210
3 1/8	in.	3.12	17.13	5.00	10.13
80	mm	79.3	435	150	257
4 1/16	in.	4.06	20.12	6.69	11.43
100	mm	103.2	511	170	290
5 1/8	in.	5.12	24.13	10.16	11.97
125	mm	130	613	258	304
7 1/16	in.	7.06	28.11	13.39	12.72
200	mm	179.4	714	340	323

API CLASS 10000 FULL BORE

SWING					
SIZE		D	RJ	B	C
2 1/16	in.	2.06	14.61	4.33	8.28
50	mm	52.4	371	110	210
3 1/8	in.	3.12	17.13	5.00	10.13
80	mm	79.3	435	150	257
4 1/16	in.	4.06	20.12	6.69	11.43
100	mm	103.2	511	170	290

CV FLOW COEFFICIENTS BALL & SLAB GATE

The Cv's a valve property defined as follows: "The Flow Coefficient Cv states the flow capacity of a valve in U.S. gallons per minute of water at standard temperature of 60°F (15,6°C) that will flow through the valve with a pressure loss of one pound per square least restrictive flow pattern inch at a specific opening position". For the metric system the analog value is Kv where the measured units are Bar, Kg and metres. The Cv of a valve in terms of pressure loss, the highest values of Cv indicate the value indicates the restrictive flow of a valve.

API 6A			
Bore (inch)	CLASSES		
	3000	5000	10000
1 13/16	270	270	230
2 1/16	350	350	300
3 1/8	1000	940	890
4 1/16	1750	1700	1600
5 1/8	2900	2700	2450
7 1/16	5930	5400	5220

API 6D						
Bore (inch)	CLASSES					
	150	300	600	900	1500	2500
2	420	420	400	330	330	250
2 1/2	690	690	610	520	510	320
3x2	200	200	200	1190	180	200
3	1200	1050	1000	910	820	500
4x3	600	600	600	590	550	560
4	2200	2100	1850	1800	1700	1100
6x4	800	800	790	790	780	745
6	5150	2100	4600	4380	3800	2500
8x6	2150	2150	2150	2150	2150	2150
8	9500	9400	9000	8500	7400	5300
10x8	4300	4200	4300	4450	4450	4100
10	15000	15000	14700	14500	11500	8300
12x10	7550	7550	7550	8000	9000	7550
14x10	6000	6000	6000	6100	6100	-
12	23000	23000	22500	21100	18000	13000
14x12	14000	14000	14000	12800	13000	-
16x12	9100	9100	9100	8900	8900	-
14	28000	28000	28000	25000	21000	-
16x14	15000	15000	15000	14200	14100	-
16	37200	37200	37200	34500	27500	-
18x16	21000	21000	21000	19200	19000	-
20x16	15300	15300	15300	13800	1200	-
18	49000	49000	49000	45000	37000	-
20x18	28400	28400	28400	25000	25000	-
20	59000	59000	59000	55200	47800	-
24x20	28200	28200	28000	25100	20600	-
22	68200	68200	68200	62000	54000	-
24	92000	92000	92000	83800	70000	-
30x24	36000	36000	36000	32900	-	-
26	111000	110000	110000	98500	-	-
28	121000	121000	121000	113000	-	-
30	145000	144000	144000	130000	-	-
36x30	64000	64000	64000	61500	-	-
32	170000	170000	170000	151000	-	-
36x32	87000	87000	87000	69500	-	-
36	210000	210000	210000	198200	-	-
40	267500	267500	267500	-	-	-
42x36	96700	96700	96000	-	-	-
42	280000	280000	280000	-	-	-
48	384000	384000	384000	-	-	-
56x42	89000	89000	89000	-	-	-
56	521000	521000	521000	-	-	-

FLOW-RATE

$$Q = C_v \sqrt{\frac{\Delta p}{S}}$$

PRESSURE DROP

$$\Delta p = S \left(\frac{Q}{C_v} \right)^2$$

For liquids other than water

p = Pressure drop (p.s.i.).

Q = Liquid flow in gallons per minute (GPM).

S = Specific gravity of liquid relative to water (60°F).

Cv = Valves flow coefficient.

CONVERSION TABLE TO METRI Kv		
Flow Coefficient	Cv	Kv
Cv	1	0.865
Kv	1.156	1



BODY MATERIALS

CARBON AND STAINLESS STEEL					
Material Group	Common Name	Nominal Type	UNS	Forging Spec.	Casting Spec. Equivalent
Carbon Steel	CS	C-Mn-Fe	K03504	A105N	A261-WCB
Low Temperature Carbon Steel	LTCS	C-Mn-Fe	K03011	A350-LF2	A352-LC A A352-LC B A352-LC C
Stainless Steel	Austenitic S.Steel 300 Series S.Steel	316: 16Cr-12Ni-2Mo	S31600	A182-F316	A351-CF8M
		316L: 16Cr-12Ni-2Mo	S31603	A182-F316L	A351-CF3M
	Duplex 2205	22Cr-5Ni-3Mo-N	S31803 S32205	A182-F51	A890-J92205
	Super Duplex 2507	25Cr-7Ni-4Mo-N	S32750	A182-F53	A351-CD4MCu A890 5A
	Super Austenitic 6Mo	20Cr-18Ni-6Mo	S31254	A182-F44	A351-CK3MCuN

EXOTIC MATERIALS					
Material Group	Common Name	Nominal Type	UNS	Forging Spec.	Casting Spec. Equivalent
Nickel-Iron Alloy	Incoloy 800	33Ni-42Fe-21Cr	N08800	B564-N08800	-
	Incoloy 825	42Ni-21.5Cr-3Mo-2.3Cu	N08825	B564-N08825	A494-CU5MCuC
Nickel	Nickel	99/95Ni	N02200	B160-N02200 (bar)	A94-Cz-100
Nickel-Copper	Monel 400	67Ni-30Cu	N04400	B56-N04400	A94-M35-1
	Monel 500	-	N05500	B564-N05500	-
Nickel-Alloy	904L	-	N08904	904L	n/a
Nickel Superalloy's	Inconel 600	72Ni-15Cr-8Fe	N06600	B564-N06600	A94-CY40
	Inconel 625	60Ni-22Cr-9Mo-5Cb	N06625	B564-N06625*	A94-CW-6MC
	Hastelloy C-276	54Ni-15Cr-16Mo	N10276	B564-N10276*	A94-CW-2M
Titanium	Titanium	98Ti	R50400	B381-GR2	B367-C2

TRIM MATERIALS

OMB	UNS	TYPE	GRADE (FORDGED)	ASTM WROUGHT	NORSOK
C/S	UNS G41400	1Cr 0,25Mo 0,40C 0,81Mn	AISI 4140	-	X02
316	UNS S31600	18-8 Cr-Ni (18-10-2)	ASTM A182 F316	A276-316	S01
17/4PH	UNS S17400	0Cr 17Ni 4Cu 4Nb	ASTM A705 UNS S17400	ASTM A564 UNS S17400	-
Duplex	UNS S31803	22Cr-5Ni-3Mo-N	ASTM A182 F51	A890J92205	D47
	UNS S32205				
Super Duplex	UNS S32750	25Cr-7Ni-4Mo-N	ASTM A182 F53	A351-CD4MCU A890 5A	D57
	UNS S32760	25Cr-7Ni-3.5Mo-N-Cu-W	ASTM A182 F55	CD3MWCUN	-
ALLOY 718	UNS N77180	NC 19 Fa NE	ASTM B637	Nc 19Fe Nt	-
MONEL(R)	UNS N04400	67 Ni-30Cu	ASTM B564-N04400	B164-N04400	-

SEAT-INSERT (PRESSURE TEMPERATURE RATING)

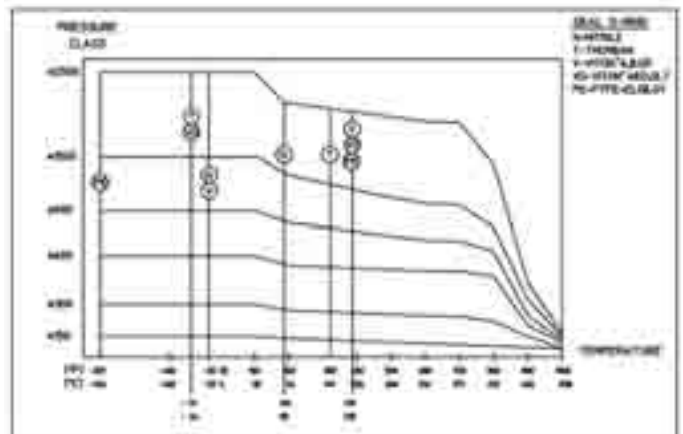
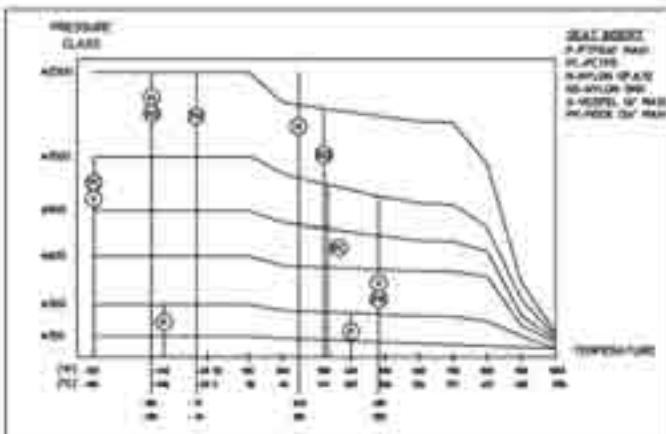

SEAT & SEAL MATERIALS

	OMB DESIGNATION	CHEMICAL NAME/DESIGNATION	TEMPERATURE RANGE	APPLICATION	TRADEMARK
ELASTOMERIC	Nitril	N.B.R	0 to + 80°C	This form of synthetic rubber is generally resistant to oil, fuel, and other chemicals. A standard material used for most applications, not A.E. compatible.	-
	Hydrogenated Nitril	H.N.B.R	-40 to + 150°C	High standard of dynamic and mechanical properties, to ensure long term operation. This is A.E.D compatible.	-
	Viton	F.K.M	-40 to + 180°C	Synthetic rubber and fluoropolymer elastomer commonly used in O-rings	Viton®
	Chemraz	F.F.K.M	-20 + 220°C	Chemraz® has the broadest chemical resistance of any elastomeric material, combining the resilience and sealing force of an elastomer with chemical resistance approaching that of PTFE. Chemraz O-rings, quad-rings, gaskets and custom elastomeric shapes last longer and seal completely in harsh environments and a wide range of temperatures.	DuPont™ Chemraz®
THERMOPLASTIC	P.T.F.E	Polytetrafluoroethylene	-100° to + 180°/220°C	Virgin PTFE is used as a standard material for its high lubricity and superior sealing up to 180°C. It is white in colour.	-
	R.P.T.F.E/Glass	Polytetrafluoroethylene. glass filled	-100° to + 200°/250°C	Reinforced PTFE seats are made with glass filled PTFE (20%). They are harder than virgin PTFE. White in colour with green or blue speckles.	DuPont™ Teflon®
	R.P.T.F.E/carbon Graphite	Polytetrafluoroethylene carbon-graphite filled	-100° to + 200°/250°C	Reinforced PTFE with 20% carbon and 5% Graphite. These seats are black in colour.	-
	POM (Delrin®)	Polyoxymethylene acetal resin	-57°C to 82°C	This material is very rigid it has a combination of strength, stiffness, hardness dimensional stability, toughness, fatigue resistance, abrasion resistance low wear and low friction. It can withstand pressure up to 5000 PSIG depending on valve size. Do not use on oxygen service.	DuPont™ Delrin®
	Nylon 12 G	Polyamide	-50° to + 120°C	Nylon 12G is more suitable than PTFE for higher pressure, but has a limited range in temperature.	-
	Devlon	Polyamide	-100° to +150°C	Devlon V is similar to Nylon 12G, but with a wider range of temperature application (lower and higher).	Devlon V®
	UHMWPE	Ultra High Molecular Weight Polyethylene	-200°C to 80°C	UHMWPE (05) is a common substitute where PTFE is not permitted and has excellent abrasion resistance.	-
	PEEK	Polyetheretherketone	-100° to 260°C	Peek is recommended for high temperature (up to 260°C) but it is very hard compared to other non metallic materials. Not applicable for concentrated sulphuric acid.	-
	PCTFE (Kel F)	Polychlorotrifluoroethylene	-250° + 150°C	PCTFE is specifically recommended for cryogenic service.	3-M™ KELF® Daikin™ Neoflon®
	Vespe® Sp21	15% Graphite Filled Polyimide	-100° to 340°C	15% Graphite filler. Performs well in a variety of chemical environments and a variety of industrial fluids at elevated temperatures.	DuPont™ Vespe®
OTHER	Graphite	-	-	High purity graphite used for backup sealing for fire resistance.	-
	Metallic	Spiral Wound	-	316 with spiral wound graphite	-
		Ring joint	-	Supplied in any of these designations manufactured out of 316 or Alloy 825 R, RX,BX,SRX&SBX	-
		Bore Seals	-	Generally of the Grayloc® type. Manufactured in Alloy 718	-

BOLTING MATERIALS

VALVE BODY MATERIAL	DESIGN TEMPERATURE RANGE (1)	BOLTING MATERIAL
Carbon steels (2)	-29 to +250° C	ASTM A 193 Gr. B7 and ASTM A 194 Gr. 2H
Low temperature Carbon Steels (2)	-46 to +250° C	ASTM A 193 Gr. B7M and ASTM A 194 Gr. 2HM or ASTM A 320 Gr. L7 or L7M and ASTM A 194 Gr. 4 or Gr. 7
Low Alloy Steel 3.5% Ni	-101 to +265° C	ASTM A 320 Gr. L7 and ASTM A 194 Gr. 4 or 7
Austenitic Stainless Steels	-196 to +300° C	ASTM A 193 or ASTM A 320 Gr. B8 or B8M cl.2 (see note 3) and ASTM A 194 Gr. 8MA or 8TA
Aluminum Bronze	-196 to +200° C	ASTM B 150 Gr. C63000 HR50
Duplex Stainless Steel to UNS 31803 or Inconel 625	-46 to +200° C	ASTM A 453 Gr. 660
Other Non-ferrous		Per applicable valve standard

(1) "Design temperature" means temperature @ design pressure for bolting.

(2) Grades B7M for studs and 2HM for nuts must be selected if valves are in H₂ service and confined under heat insulation.

(3) Stainless steel bolting to ASTM A 193 Gr. B8 or B8M may conform to class 1 instead of class 2 for bolt diameters larger than 1^{1/2} inch. A 453 Gr. 660 may also be used down to minus 100°C if satisfactorily tested at that temperature.

FRACTION OF 1 INCH INTO DECIMALS AND MILLIMETERS

FRACT.	INCH.	MILLIM.	FRACT.	INCH.	MILLIM.	FRACT.	INCH.	MILLIM.	FRACT.	INCH.	MILLIM.
1/64	0.016	0.397	17/64	0.266	06.747	33/64	0.516	13.097	49/64	0.766	19.447
1/32	0.031	0.794	9/32	0.281	07.141	17/32	0.531	13.494	25/32	0.781	19.844
3/64	0.047	1.191	19/64	0.297	07.541	35/64	0.547	13.891	51/64	0.797	20.241
1/16	0.062	1.587	5/16	0.312	07.937	5/8	0.562	14.287	13/16	0.812	20.637
5/64	0.078	1.984	21/64	0.328	08.334	37/64	0.578	14.684	53/64	0.828	21.034
3/32	0.094	2.381	11/32	0.344	08.731	19/32	0.594	15.081	27/32	0.844	21.431
7/64	0.109	2.778	23/64	0.359	09.128	39/64	0.609	15.478	55/64	0.859	21.828
1/8	0.125	3.175	3/8	0.375	09.525	5/8	0.625	15.875	7/8	0.875	22.225
9/64	0.141	3.572	25/64	0.391	09.922	41/64	0.641	16.272	57/64	0.891	22.622
5/32	0.156	3.969	13/32	0.406	10.319	21/32	0.656	16.669	29/32	0.906	23.019
11/64	0.172	4.365	27/64	0.422	10.716	43/64	0.672	17.066	59/64	0.922	23.406
3/16	0.187	4.762	7/16	0.437	11.112	11/16	0.687	17.462	15/16	0.937	23.812
13/64	0.203	5.159	29/64	0.453	11.509	45/64	0.703	17.859	61/64	0.953	24.209
7/32	0.219	5.556	15/32	0.469	11.906	23/32	0.719	18.256	31/32	0.969	24.606
15/64	0.234	5.953	31/64	0.484	12.303	47/64	0.734	18.653	63/64	0.984	25.003
1/4	0.250	6.350	1/2	0.500	12.700	3/4	0.750	19.050	1	1.000	25.400



PRODUCT INFORMATION REQUEST Request to send the following printed catalogs in copies:

From..... Company.....

Address..... City.....

Zip Code..... Country.....

To: **OMB Valves s.p.a.**
 Fax: **+39 035 942638**

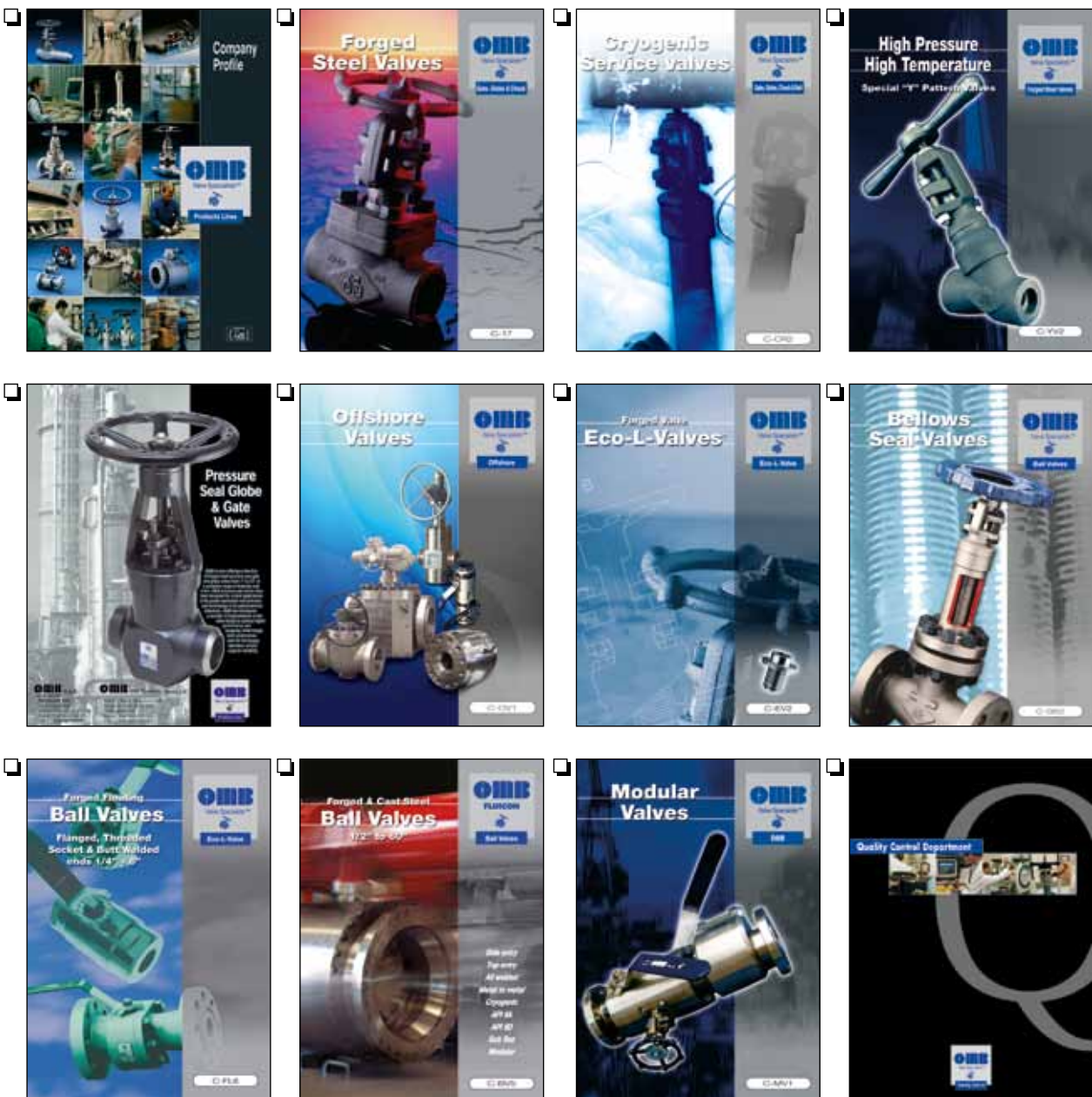

Catalogs can be downloaded at www.ombvalves.com

HEADQUARTERS

Via Europa, 7
24069 Cenate Sotto (Bg) - Italy
Phone +39 035 425 67 11
Fax +39 035 942 638
www.ombvalves.com

Worldwide Network
of Agents and Distributors

OMB Offshore Application Ltd.

DUNDEE, UNITED KINGDOM
Phone +44 (0) 138 277 2992 - Fax +44 (0) 138 273 2402

OMB Valves Inc.

SUGAR LAND, TX - U.S.A.
Phone +1 832 886 2750 - Fax +1 832 886 2850

OMB Valves

Rep. office MONTREAL - CANADA
Phone +1 514 457 0813 - Fax +1 514 457 0814

OMB Valves Asia Pte. Ltd.

WOODLAND - SINGAPORE
Phone +65 685 221 10 - Fax +65 685 214 10

OMB Valves

Rep. office SOUTH EAST ASIA & PACIFIC (MALAYSIA)
Phone +60 (0) 3 806 275 96 - Fax +60 (0) 3 806 285 73

OMB Valves

Rep. office TOKYO - JAPAN
Phone +81 48 479 0960 - Fax +81 48 479 0960

OMB Valves

Rep. office SEOUL - KOREA
Phone +82 70 8244 0578 - Fax +82 2 2668 4151

OMB Valves

Rep. office BEIJING - CHINA
Phone +86 134 0113 0025 - Fax +86 10 5792 6036

IVM OMB Saudi

AL-KHOBAR - SAUDI ARABIA
Phone +966 3 889 3334 - Fax +966 3 889 3332

