



3 & 4 Way Multi-Port Ball Valves

MULTI-PORT SERIES

Extremely Versatile Valve Design for Diversion or Mixing

Models:

Flanged End

ANSI/Class 150

MPF15

ANSI/Class 300

MPF 30

Threaded End

300 lb MPT 30

Tri-Clamp - MPC 15

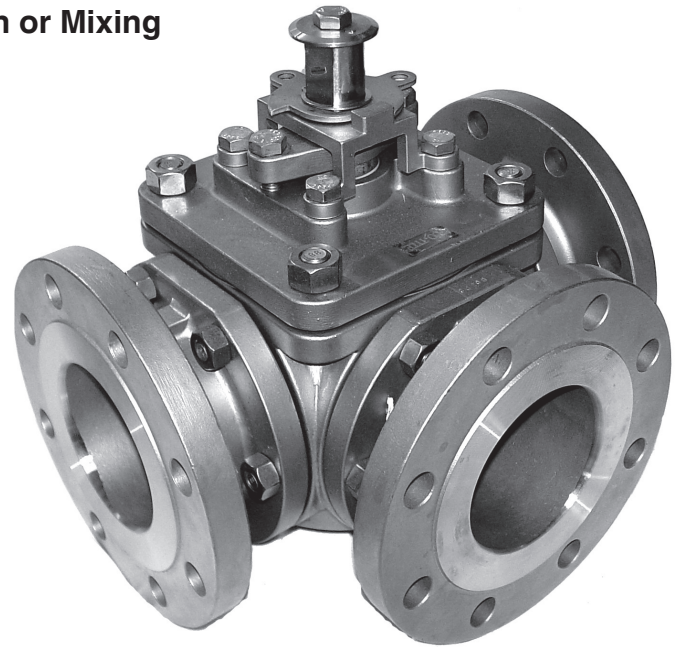
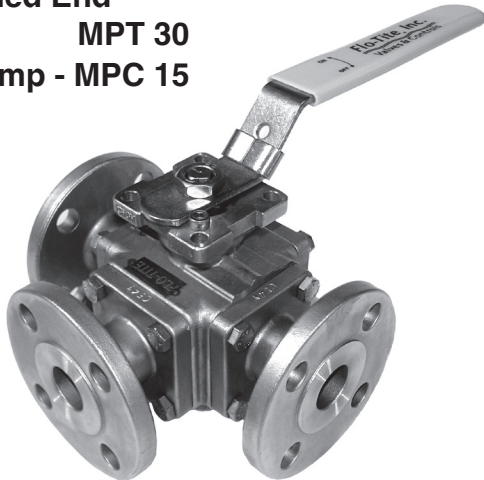

DESIGN FEATURES

- One Piece Ball/Stem Trunnion - Supported Type
- 3 Seat Design Maintains Proper Ball Position
- Actuator Mounting Pad
- Anti-Static Grounding Device
- Open And Closed Locking Device for Positional Safety Lockout

Sizes 3/4" thru 12"

- Flow Plans for Both T & L Ports can be field rearranged to meet many other Flow Plans
- Both T & L Valves can be offered with an off position
- Body Cavity fillers for sizes 3/4 - 4 inch
- Full Port 3/4 Thru 12 inch
- Standard Bore 6 Thru 12 inch

Simplify All Aspects of Piping Systems with Flo-Tite's Multiport Ball Valves

www.flotite.com

**DESIGN AND TECHNICAL DATA
SPECIFICATION STANDARDS:**

Flanges ANSI B16.5
Shell/Wall ANSI B16.34

Federal Specifications
WWW-V-35B Valve, Ball, Type II
Class C, Style 3, End Connection B

TESTING
MODEL MPF15
Class 150 Shell 425 psi
 Seat (Air) 80 psi

MODEL MPF30
Class 300 Shell 1100 psi
 Seat (Air) 80 psi

- FEATURES**
- Grounded Ball & Stem
 - Full Port Ball Orifice
 - Four-Bolt Actuator Mounting
 - Multiple Piece Stem Packing
 - Unique One Piece Ball and Stem Design
 - Cavity Fillers are Available for Size 3/4 thru 4 inch
 - Optional Metal Seats

NOTE: A variety of alloys as well as special seating materials are available, Consult Factory.

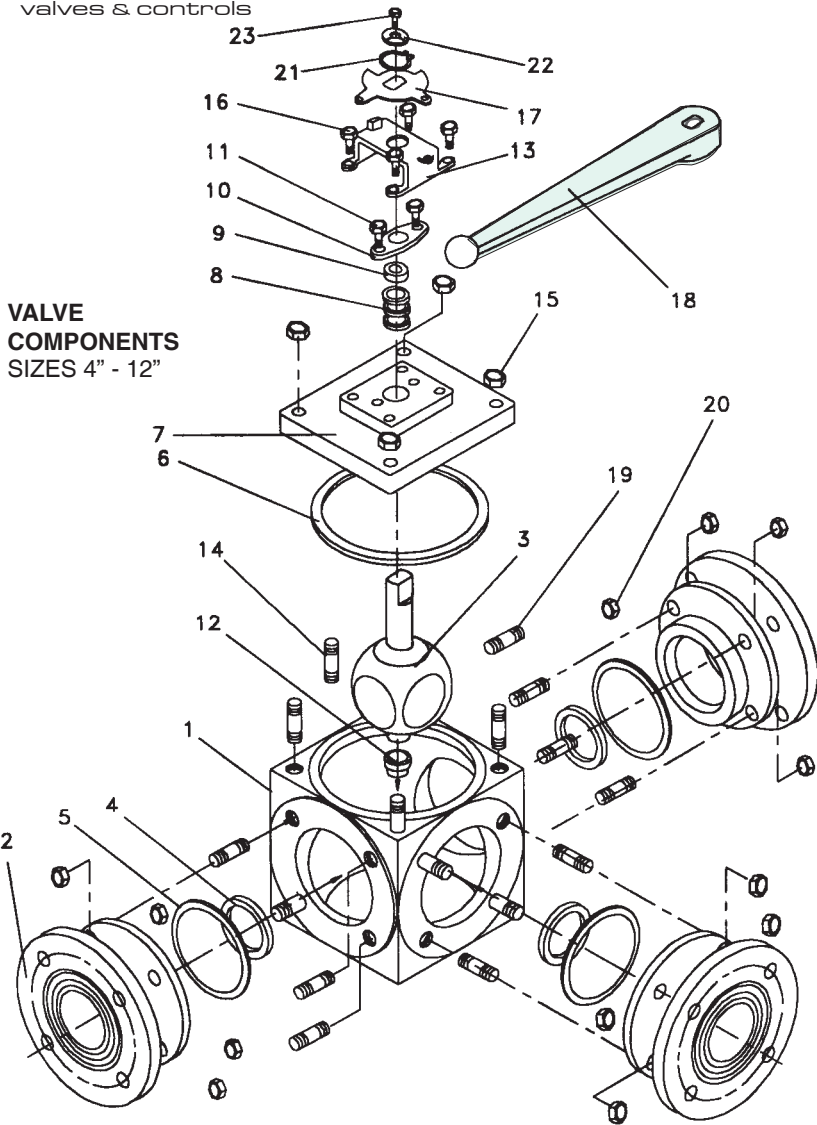

**VALVE COMPONENTS
SIZES 4" - 12"**

PRESSURE AND TEMPERATURE DATA:

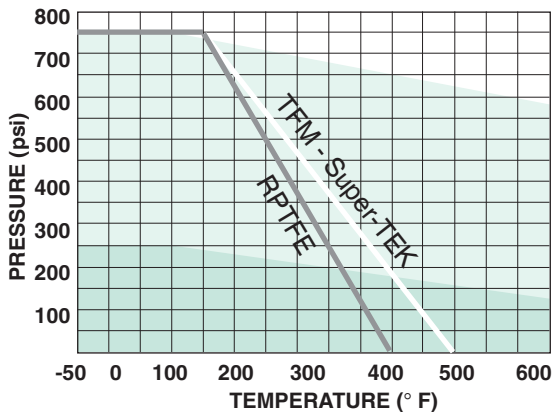

Class 150 Valve Bodies
 RPTFE
 Class 300 Valve Bodies
 TFM-Super-TEK

Rating Curve applies to both "L" and "T" port configurations.
All Values conform to ANSI Class pressure ratings. They are rated for a maximum differential pressure of 275 psi, and a maximum temperature of up to 550 °F. WCB - 285 psi Max. Complies with ANSI B16.5 and B16.34 standards.

BILL OF MATERIALS:

ITEM	NAME	MPF15-SS	MPF 15-CS
1	BODY	A351 GR CF8M	A216 GR WCB
2	END CONNECTOR	A351 GR CF8M	A216 GR WCB
3	BALL	A351 TYPE316	A351TYPE316
4	SEAT *	TFM Super-Tek	TFM Super-Tek
5	END GASKET *	50/50	50/50
6	COVER GASKET *	50/50	50/50
7	COVER	A351 GR CF8M	A216 GR WCB
8	STEM PACKING	TFM Super-TEK	TFM Super-TEK
9	GLAND RING	A167 TYPE304	CARBON STEEL
10	GLAND	A167 TYPE304	CARBON STEEL
11	GLAND BOLT	B8	B7
12	THRUST BEARING *	50/50	50/50\
13	STOP HOUSING	A351 GR CF8M	CARBON STEEL
14	COVER STUD	B8	B7
15	COVER NUT	A167 TYPE304	CARBON STEEL
16	HOUSING BOLT	B8	B7
17	TRAVEL STOP	A167 TYPE304	CARBON STEEL
18	LEVER	DUCTILE IRON	DUCTILE IRON
19	BODY STUD	B8	B7
20	BODY NUT	A167 TYPE304	CARBON STEEL
21	SNAP RING	SK5 CR PLATE	SK5 CR PLATE
22	PORT SIGN	A167 TYPE304	A167 TYPE304
23	SIGN NUT	A167 TYPE304	A167 TYPE304

* Repair Parts

DIMENSIONS:

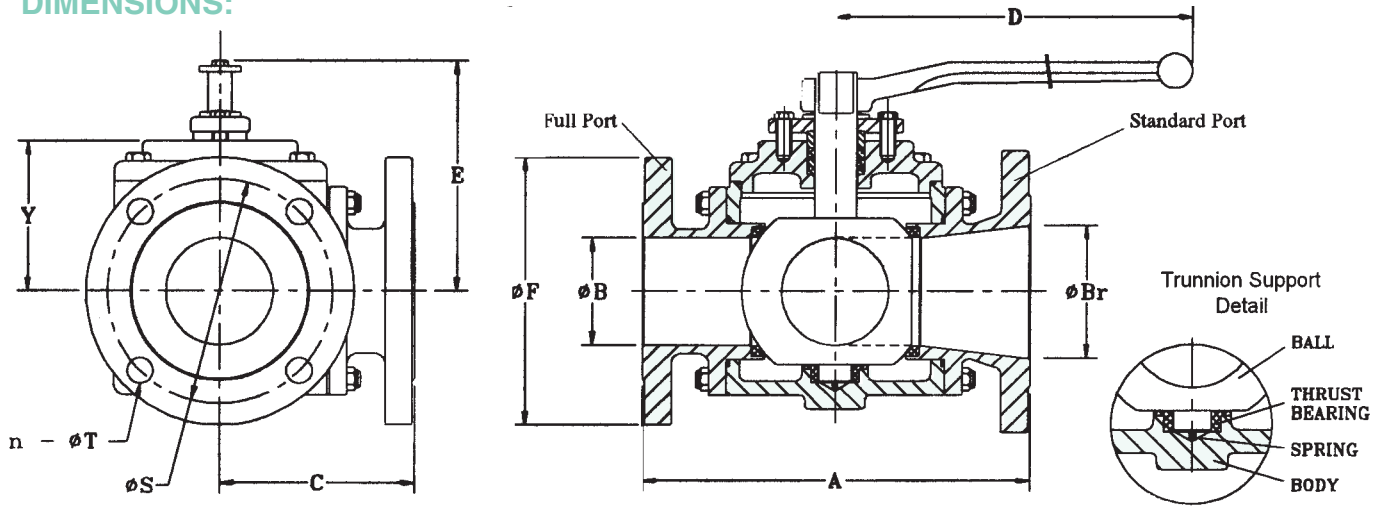

MPF15 (Full Port):

SIZE		3/4"	1"	1-1/2"	2"	3"	4"	6"	8"	10"	12"
A	in.	6.65	7.3	7.17	8.66	11.26	13.66	16.77	20.94	27.56	29.92
	mm	169	185	182	220	286	347	426	532	700	760
øB	in.	0.75	1.0	1.50	2.01	3.00	4.02	5.98	7.95	9.84	11.77
	mm	20	25	40	51	76	102	152	202	250	300
C	in.	3.33	3.65	3.57	4.33	5.62	6.85	8.47	10.63	13.78	15.02
	mm	84.5	92.5	90.5	110	143	174	215	270	350	381.5
D	in.	7.48	8.38	15	15	15	20				
	mm	190	212.5	380	380	380	530				
E	in.	3.16	3.28	4.10	4.92	6.68	8.03	10.04	11.54	13.00	14.55
	mm	80	83	104	125	170	204	255	293	330	370
øF	in.	3.88	4.25	5.00	5.99	7.52	9.01	11.00	13.50	16.00	18.99
	mm	98.5	108	127	152	191	229	279	343	406	483
n		4	4	4	4	4	8	8	8	12	12
øS	in.	2.75	3.12	3.88	4.75	6.00	7.50	9.50	11.75	14.25	17.18
	mm	70	79	98.5	120.5	152.4	190.5	241.3	298.4	361.9	437
øT	in.	0.63	0.63	0.63	0.75	0.75	0.75	0.9	0.90	1.02	1.26
	mm	16	16	16	19	19	19	22	22	26	32
Y	in.	2.62	2.66	2.48	2.87	3.62	4.88	6.50	7.60	9.06	10.97
	mm	66.6	67.6	63	73	92	124	155	193	230	279
CV	90°	16	30	50	100	240	400	970	1,850	3,500	
	180°	40	70	230	390	930	1,650	5,000	9,000	16,000	
Torque (in-lbf)		250	385	480	700	1,600	2,800	8,600	15,500	C/F	C/F
Weight (lbs)		12	16	20	36	72	128	250	450	850	C/F

MPSF15 (Standard Port):

SIZE		6"	8"	10"	12"
A	in.	16.85	20.94	26.77	29.57
	mm	428	532	680	751
øBr	in.	5.98	7.95	9.84	11.81
	mm	152	202	250	300
øB	in.	4.02	5.98	7.95	9.84
	mm	102	152	202	250
C	in.	7.05	9.01	11.57	13.78
	mm	179	229	294	350
E	in.	8.03	10.35	11.88	12.83
	mm	204	263	302	326
øF	in.	11.00	13.50	16.00	19.00
	mm	279	343	406	483
n		8	8	12	12
øS	in.	9.50	11.75	14.25	17.00
	mm	241.3	298.4	361.9	432
øT	in.	0.9	0.9	1.02	1.02
	mm	22	22	26	26
Y	in.	4.64	6.50	7.60	9.06
	mm	119	165	193	230
CV	90°	C/F	C/F	C/F	C/F
	180°	C/F	C/F	C/F	C/F
Torque (in-lbf)		2900	9500	16500	C/F
Weight (lbs)		170	260	510	690

Gear Operators are recommended on size 6" and larger. Consult Factory for dimensions on MPF30 and 4-Way valves.

ACTUATOR MOUNTING PAD:

Size 3/4" - 1 1/2"

Size 2" - 12"

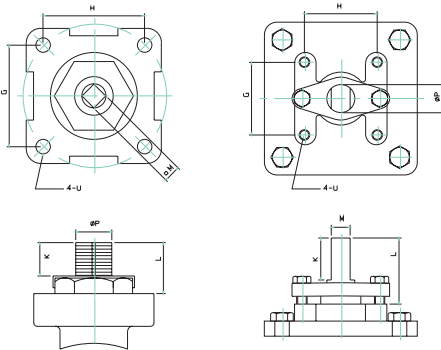

IMPORTANT: Verify the mounting dimensions before manufacturing mounting hardware.

MOUNTING DIMENSIONS:

SIZE	MPF15	3/4"	1"	1 1/2"	2"	3"	4"	6"	8"	10"	12"
	MPSF15						6"	8"	10"	12"	N/A
G	in	1.95	1.95	1.95	1.89	1.89	3.50	3.50	4.53	4.53	4.53
	mm	49.5	49.5	49.5	48	48	89	89	115	115	115
H	in	1.95	1.95	1.95	2.83	3.50	3.50	3.50	4.53	4.53	4.53
	mm	49.5	49.5	49.5	72	89	89	89	115	115	115
K	in	0.47	0.47	0.63	1.57	1.97	2.44	2.36	2.36	2.76	2.76
	mm	12	12	16	40	50	62	60	60	70	70
L	in	0.49	0.53	0.73	1.93	3.15	3.15	3.54	3.27	4.29	4.33
	mm	12.5	13.5	18.5	49	80	80	90	83	109	110
M	in	0.354	0.433	0.551	0.669	0.669	0.906	1.378	1.772	1.772	2.165
	mm	9	11	14	17	17	23	35	45	45	55
øP	in	0.46	0.55	0.61	0.87	1.16	1.34	1.77	2.36	2.36	2.76
	mm	11.8	14	15.5	22	29.5	34	45	60	60	70
U	in	ø0.33	ø0.28	ø0.36	5/16-18	1/2-13	1/2-13	1/2-13	5/8-11	5/8-11	5/8-11
	mm	ø8.5	ø7	ø9.2							

Flo-Tite's UNIQUE DESIGN FEATURES

Optional End Connections



Tri-Clamp Ends



NPT

One Piece Stem/Ball Trunnion Support Design

provides for precision operation and positioning of the ball. This precise ball positioning is often not possible in more common multi-piece stem ball design. This also allows all sides to be used as an inlet or block port without leakage.

Sizes 3/4 thru 12 inch offer a three seat design as standard. A fourth seat can be added to aid in balancing the ball for optional control during modulation.

Standard Locking Device

All Valves can be padlocked to limit unwanted access.

FLOW PATTERNS

All T-Port Flow Patterns can be changed in the field without disassembling valve

T-PORT: 90°

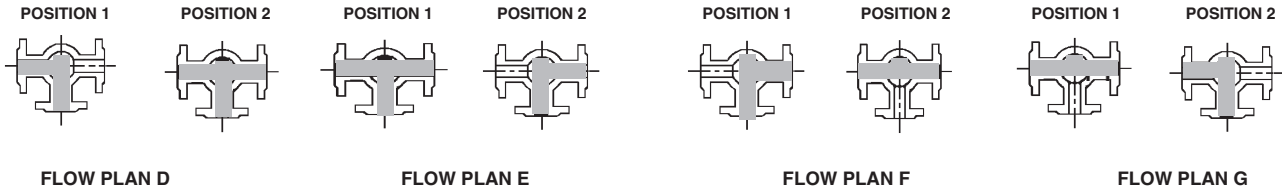

T-PORT: 180°

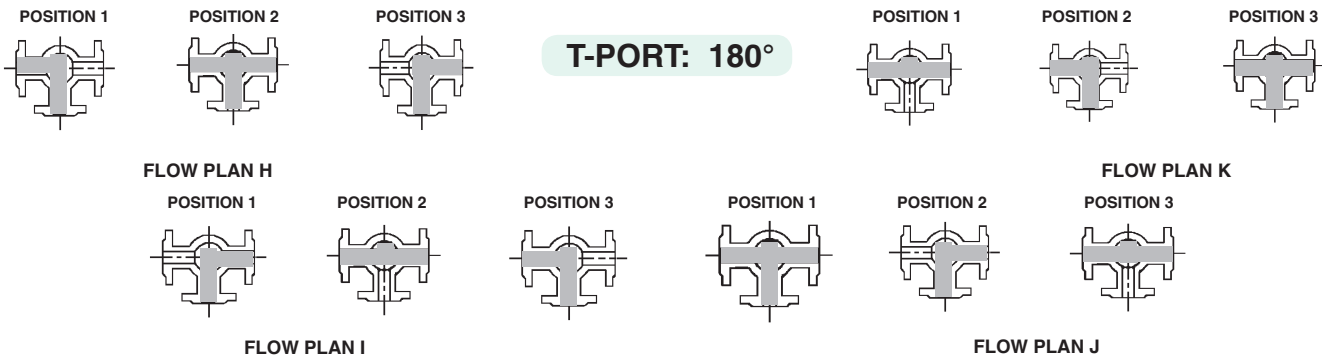

DIVERTER TYPE

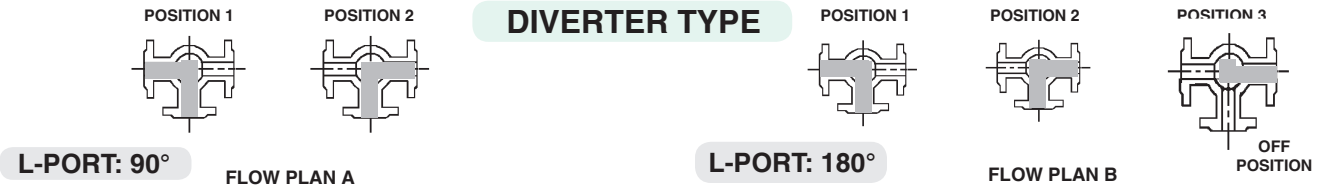

4-WAY VALVES

FLOW PLAN M - 4-WAY LL PORT 90° TURN

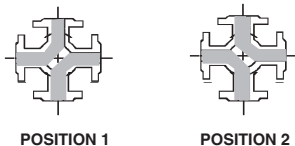

POSITION 1

POSITION 2

Optional Plans Available Using T, L, and Standard Ball Consult Factory

FLOW PLAN N - 4-WAY L PORT 180° TURN



POSITION 1

POSITION 2