



3PC HIGH PRESSURE BALL VALVES

TITAN SERIES

Engineered Valves For High Pressure Severe Service Applications

MODELS

- 1540 Series: Carbon Steel
- 1550 Series: Stainless Steel

- ANSI Class 1500/900
- Both RF & RTJ Flanged Ends
- NPT, Socket & Butt Weld - 5000 WOG
- Extended Weld End Optional

- Standard Ball & V Port
- Control Valves

Available Materials

- LCC & 316SS
- Specials

Seat Options

- Delrin, Devlon, PEEK, Metal

Size Range:

1/2" - 2"

Captive Seals

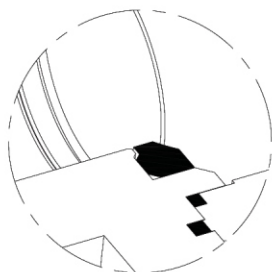

Detail of Protected seat & encapsulated body seal design. Isolates & protects both seats and seals from flow path. Helps to prevent cold flow.

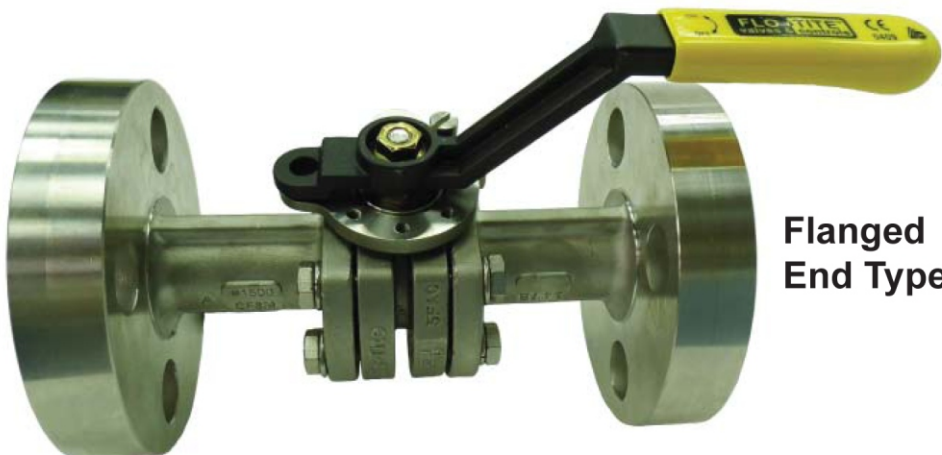

Flanged End Type



Threaded End Type

Design Features:

<ul style="list-style-type: none"> • 3PC Bolted Body Design • Blow-out Proof Stem Design • 17-4PH Stem Standard • Heavy Duty, Rugged Construction • Lockable Handles • API 607-5th Edition Fire Safe • API 608 Compliance • Anti-Static Ground • Casting Traceability • Actuator Mounting Pad, ISO5211 	<ul style="list-style-type: none"> • Ability to handle Pressure and Temperature Shock • Ability to withstand Higher Pressure Drop • Ability to handle Slurries and Resist Abrasion and Wear • Ability to handle Thermal Fluid and Super Heated Steam • Bubble Tight Sealing to 5000 psi • Metal Seat Classes V & VI Shut Off
--	--

Ideal for Steam, Hydraulic, Petrochemical, and many other industries that require high pressure ball valves

Design Specifications and Standards of Compliance

Flo-Tite's High Pressure 3PC Titan Series

Technical Specifications

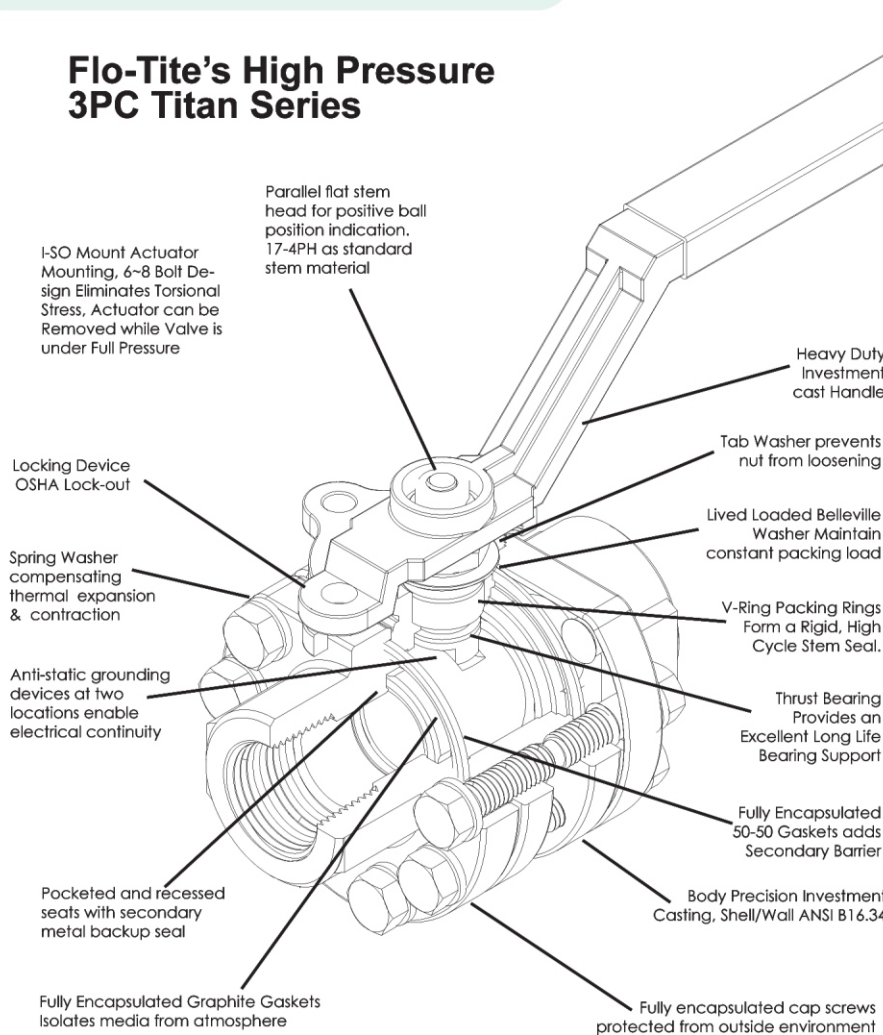

All Titan series valves are designed to meet ASME/ANSI B16.34 class 900 & 1500 specifications and can be certified as such upon request at order submittal.

Threaded End Connections meet ASME/ANSI B1.20.1 NPT
Socket Weld End Connections meet ASME/ANSI B16.11.
Butt Weld End Connections meet MSS SP72, ANSI B16.25
Flanged End Connections meet ASME/ANSI Class 900/1500, ASME/ANSI B16.10 and B16.5

MSS SP25 compliance for standard marking system
All Titan Valves meet NACE MR0175 for sour gas service.
All valves are Fire Safe and certified to API 607 5th Edition. Fire Safe Designed Valves must have Graphite Stem packing.

Federal Spec WW-V-35C Type II valve body and end connections are high quality investment cast and solution annealed/ normalized.

All valves are hydrostatically shell tested to 1.5 x rating. All valves 100% air tested under water at 80-100 psi. Complies with API-598

Standard Valve Suitable to 25 Torr Vacuum
Specially cleaned valves can handle services of 0.02 mm. of Hg (20 micron).

Quality Assurance
All valves are manufactured to ISO 9001 quality standards

Standards and Specifications

Valves covered in this bulletin are available to conform to the following industry standards and specifications

All Valves are Manufactured to ISO 9001 Quality Standards

WW-V-35C	Federal Specification: Valve, Ball
ANSI/ASME B16.10	Face-to-Face / End-to-End Dimensions of Ferrous Valves
ANSI/ASME B16.5	Steel Pipe Flanges and Flange Fittings
ANSI/ASME B16.34	Steel Valves - Flanged and Buttwelded End
ANSI/ASME B31.1	Power Piping
ANSI/ASME B31.3	Chemical Plant & Petroleum Refinery Piping
ANSI/FCI70-2-1976	For Control Valve Leakage
BS 6755, Part 2	Testing of Valves-Specification for Fire Type Testing
ISA 5752:1982	Metal Valves for use in Flange Piping Systems
ISA 75.02	Valve Sizing Coefficient Cv, Piping Geometry Factor Fp & Pressure Drop Limitation XT
ISA S75.19	Hydrostatic Testing of Control Valves
ISO 5211	Dimensions for Attachment of Actuators/ Gear Boxes to Valves (ISO Mounting)
MSS-SP-25	Standard Marking Systems for Valves

MSS-SP-55	Quality Standards for Steel Casting
MSS-SP-6	Standard Finishes for Contact Faces of Pipe Flanges and Connecting-End Flanges of Valve and Fittings
MSS-SP-44	Steel Pipe Line Flanges
MSS-SP-61	Pressure Testing of Steel Valves
MSS-SP-72	Ball Valves with Flanged or Butt-Welding Ends for General Service
MSS-SP-96	Terminology for Valves and Fittings
NACE MR0175	Sulfide Stress Cracking Resistant Materials for Oilfield Equipment
API 608	Metal Ball Valves Used in on-off Service that have Buttwelded or Flanged Ends for Size 1/2"-12" NPS
API 6D	Specifications for Pipeline Valves
API 598	Valve Inspection and Testing
MSS-SP-53	Quality Standard for Steel Casting and Forging for Valves, Flanges and Fittings and Other Piping Component - Magnetic Particle Examination Method
MSS-SP-93	Quality Standard for Steel Casting and Forging for Valves, Flanges and Fittings and Other Piping Components - Liquid Penetrant Method

Design and Technical Data

Exploded View

Models
Titan Series
5000 WOG
ANSI Class 1500

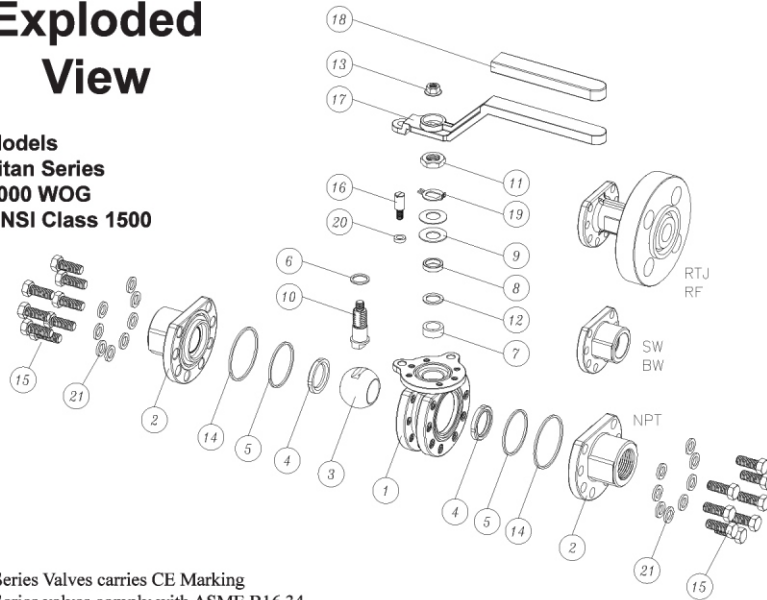

Titan Series Valves carries CE Marking
Titan Series valves comply with ASME B16.34.
All valves are tested to ASME B16.34 and API 598
Threaded End Connections meet ASME/ANSI B1.20.1

Materials of Construction

No.	Parts	Stainless Steel	Carbon Steel
1	Body	ASTM A351 CF8M	ASTM A352 LCC
2	End Cap	ASTM A351 CF8M	ASTM A352 LCC
3	Ball	A351 CF8M / SS316	A351 CF8 / SS304
4	Seat	DELRIN / PEEK	DELRIN / PEEK
5	Inner Gasket	50%SS + PTFE	50%SS + PTFE
6	Thrust Washer	25% Carbon + PTFE	25% Carbon + PTFE
7	Stem Packing	Graphite	Graphite
8	Gland	SS304	SS304
9	Belleville Washer	SS301	SS301
10	Stem	17-4PH	17-4PH
11	Packing Nut	SS304	SS304
12	Packing Protector	25% Carbon + PTFE	25% Carbon + PTFE
13	Handle Nut	Carbon Steel	Carbon Steel
14	Outer Gasket	Graphite	Graphite
15	Bolt	A193 B8 / SS304	A320 L7M / Carbon Steel
16	Handle Stopper	SS304	Carbon Steel
17	Handle	Carbon Steel	Carbon Steel
18	Handle Cover	PVC	PVC
19	Nut Lock	SS304	SS304
20	Stop Washer	SS304	Carbon Steel
21	Spring Washer	SS304	Carbon Steel

Ball Design Added Safety Feature

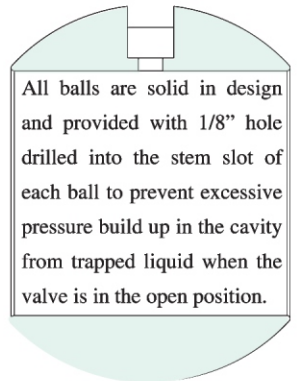

All balls are solid in design and provided with 1/8" hole drilled into the stem slot of each ball to prevent excessive pressure build up in the cavity from trapped liquid when the valve is in the open position.

Flo-Tite's HI-TEK Stem Assembly

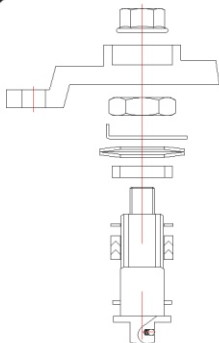

Flo-Tite's Van Guard Seal, state of the art stem sealing system. Incorporating a set of valve stem seals. This unique system eliminates the possibility of valve stem leaks in most all media applications.

Improved thrust washer design allows more sealing surface effectively blocking all leak paths during rotation.

V-Ring Packing Set expands sideways as it is compressed and pressurized blocking all air pockets. The Van-Guard stem system is energized by Belleville washers which continuously adjusts packing compression to compensate for wear, pressure or temperature fluctuation.

Note: Standard Valve is Fire Safe Design with Graphite Packing

TITAN Series - Product Identification Code for Full Valve Model Numbers

MODEL	BODY MATERIAL		2ND END CONNECTION		SEAT		STEM SEAL		BODY SEAL		OPERATOR		SIZE	
SS - Full Port NPT 1551 - SS SW 1552 - SS BW 1553 - SS #1500 RF 1558 - SS #1500 RTJ 1559 - SS	316SS	SS	Threaded	1	Delrin	D	TFM	F	TFM	F	Lever Locking	L	1/4	8
	WCB	CS	Socket Weld	2	CTFM	Y	CTFM	Y	RTFM	X			3/8	10
	LCC	LC	Butt Weld	3	DEVLON	V	RPTFE	R	RPTFE	R	Oval Locking	O	1/2	15
	Alloy 20	A2	#1500 RF	8	RPTFE	R	50/50	S	50/50	S			3/4	20
LC - Full Port NPT 1541 - LC SW 1542 - LC BW 1543 - LC #1500 RF 1548 - LC #1500 RTJ 1549 - LC	316L	SL	#1500 RTJ	9	50/50	S	UHMWPE	U	UHMWPE	U	Gear	G	1	25
					UHMWPE	U	Graphite	G	Graphite	G	Deadman	SR	1 1/4	32
					PEEK	P					Actuator	A	1 1/2	40
					Cavity Filled	C					Bare Stem	N	2	50
					Metal	M							2 1/2	65

Special Features: are noted at the end of the identification number, please see special feature codes.

For extended number, see Tech Bulletin page 191.

Ball: All ball material is supplied standard as 316SS & 304SS. If different material is required please specify as special feature.

Stem: All stem material is supplied standard as 17-4PH. Please specify as special feature if SS316 is needed.

Standard Valves Are Fire Safe with Graphite Seals

Ordering Example by Part Numbers

MODEL	BODY MATERIAL	2ND END CONNECTION	SEAT	STEM SEAL	BODY SEAL	OPERATOR	SIZE	SPECIAL FEATURE
NPT End Full Port LCC Body	LCC	SW	PEEK	Graphite	Graphite	Lever	2"	Media Containment
1541	LC	2	P	G	G	L	50	H3

Ordering Information

When placing an order or requesting a quotation, please provide as many details on the application as possible such as media type, temperature, pressure, pipe size, and etc.

Dimensions and Weights

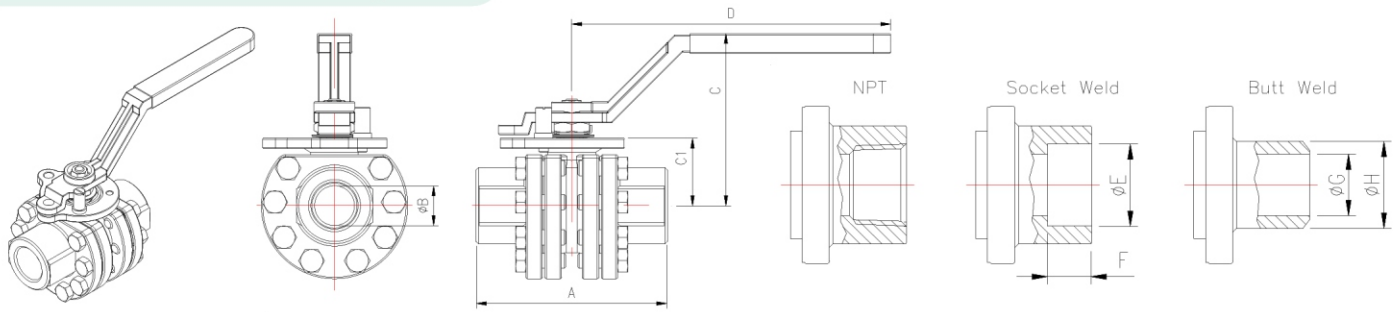

End Connections Threaded Socket Weld Butt Weld

SIZE	A			B	C	C1	D	E	F	G	H	Cv	Break Torque In-Lb *		Weight Lbs
	NPT	SW	BW										1500 psi	4000 psi	
1/2"	3.35	3.35	3.35	0.59	3.66	1.65	6.30	0.86	0.39	0.496	0.882	15	165	198	4.06
3/4"	4.13	4.13	4.13	0.79	3.96	1.65	6.30	1.07	0.51	0.638	1.094	35	280	336	5.73
1"	4.72	4.72	4.72	0.98	4.21	1.97	7.87	1.33	0.51	0.846	1.366	68	581	697	7.5
1 1/2"	5.91	5.91	5.91	1.50	5.55	2.76	10.43	1.91	0.51	1.272	1.941	155	1618	1900	22.4
2"	6.30	6.30	6.30	1.50	5.55	2.76	10.43	2.41	0.63	1.630	2.417	155	1741	2050	23.7

*Note: Torques are for clean liquid media only

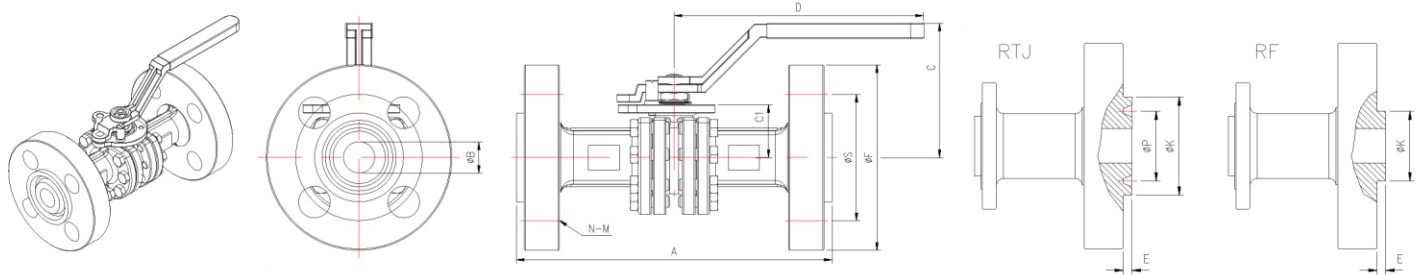

Flanged Ends ANSI Class 900/1500

SIZE	A		B	C	C1	D	E		F	K		M	N	P	S	Cv	Break Torque In-Lb *		Weight Lbs
	RF	RTJ					RF	RTJ		RF	RTJ						1500 psi	4000 psi	
1/2"	8.50	8.50	0.59	3.66	1.65	6.30	0.25	0.25	4.75	1.38	2.38	0.88	4	1.562	3.25	15	165	198	12.4
3/4"	9.00	9.00	0.79	3.96	1.65	6.30	0.25	0.25	5.12	1.69	2.62	0.88	4	1.750	3.50	35	280	336	16.4
1"	10.0	10.0	0.98	4.21	1.97	7.87	0.25	0.25	5.88	2.00	2.81	1.00	4	2.000	4.00	68	581	697	23.5
1 1/2"	12.0	12.0	1.50	5.55	2.76	10.43	0.25	0.25	7.00	2.88	3.62	1.12	4	2.688	4.88	155	1618	1900	48.2
2"	14.5	14.62	1.50	5.55	2.76	10.43	0.25	0.312	8.50	3.62	4.88	1.00	8	3.750	6.50	155	1741	2050	70.7

*Note: Torques are for clean liquid media only

Mounting Dimensions

Size	d	G	I	K	K1	L	M	N	P	ISO
1/2"	M6	1.65	0.28	0.413	0.256	0.591	M5	6	M10	F04
3/4"	M8	1.65	0.33	0.559	0.394	0.807	M5	6	M12	F04
1"	M8	1.97	0.39	0.583	0.354	0.965	M6	6	M14	F05
1 1/2"	M10	2.76	0.47	0.866	0.512	1.248	M8	8	3/4-10unc	F07
2"	M10	2.76	0.47	0.866	0.512	1.248	M8	8	3/4-10unc	F07

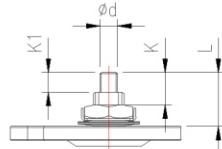
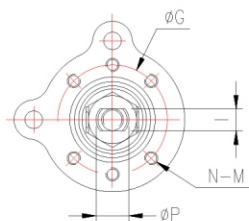

IMPORTANT:
Verify mounting dimensions before manufacturing mounting hardware

Actuator Mounting Pad with 6 or 8 Threaded Holes. The Bolting Circle Diameter Complies w/ ISO 5211

Pressure/Temperature Chart

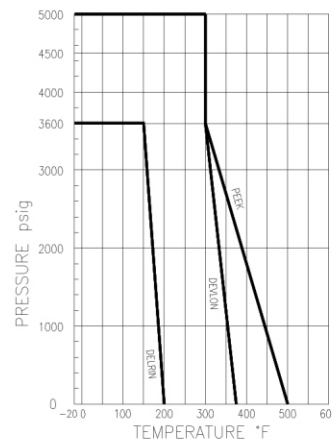

Titan Series Metal Seated Valves

High Temperature Metal Seated Ball Valves Are Well Suited for a variety of demanding services when high temperature and abrasive solids are present. Shut off classes V & VI available



Flo-Tite, Inc.
4815 West 5th St.
Lumberton, NC 28358

P. O. Box 1293
Lumberton, NC 28359
Website: www.flotite.com

Tel: (910) 738-8904
Fax: (910) 738-9112
E-mail: flotite@flotite.com

Due to continuous development & improvement of our product range, we reserve the right to alter the dimensions and techcal data included in this brochure