

# Bronze Valves

Gate Valves

Globe Valves

Check Valves



**CRANE**<sup>®</sup>

Energy Flow Solutions





# Bronze Valves

## Index

Cross Reference .....	2
General Data .....	3
Materials .....	4
Ratings .....	5
Pressure/Temperature Ratings and Flow Data .....	6

## Bronze Valve Selection Guide & Figure Number Index

Catalog Page No.	CRANE Figure No.	Pressure Rating	Stem: RS or NRS	Bonnet/Cap: TB,UB,SC,UC	End Connections	Seat: IB or SS	Disc
<b>1700 Series Bronze Valves</b>							
8	1700	Class 125	RS	TB	THD	IB	SW
9	1700S	200 CWP	RS	TB	SLD	IB	SW
10	1701	Class 125	NRS	TB	THD	IB	SW
11	1701S	200 CWP	NRS	TB	SLD	IB	SW
12	1702	Class 125	RS	TB	THD	IB	PTFE
13	1702S	200 CWP	RS	TB	SLD	IB	PTFE
14	1703	Class 125	RS	TB	THD	IB	PTFE
15	1703S	200 CWP	RS	TB	SLD	IB	PTFE
16	1707	Class 125		TB	THD	IB	BRZ
17	1707S	200 CWP		TB	SLD	IB	BRZ
<b>Bronze Gate Valves</b>							
19	428	Class 125	RS	TB	THD	IB	SW
20	428UB	Class 125	RS	UB	THD	IB	SW
21	438	Class 125	NRS	TB	THD	IB	SW
22	1324	300 CWP	NRS	TB	SLD	IB	SW
23	431	Class 150	RS	TB	THD	IB	SW
24	431UB	Class 150	RS	UB	THD	IB	SW
25	437	Class 150	NRS	TB	THD	IB	SW
26	429	Class 150	NRS	TB	FLG	IB	SW
27	1320	200 CWP	NRS	TB	SLD	IB	SW
28	1330	200 CWP	RS	TB	SLD	IB	SW
29	422	Class 200	RS	UB	THD	IB	SW
30	424	Class 200	RS	UB	THD	SS	SW
31	426	Class 200	NRS	UB	THD	SS	SW
32	622E	Class 300	RS	UB	THD	IB	SW
33	634E	Class 300	RS	UB	THD	SS	SW
34	636E	Class 300	NRS	UB	THD	SS	SW
<b>Bronze Globe Valves</b>							
37	1	Class 125	RS	TB	THD	IB	BRZ
37	5TF	Class 125	RS	TB	THD	IB	PTFE
38	7TF	Class 150	RS	UB	THD	IB	PTFE
39	1310	300 CWP	RS	TB	SLD	IB	PTFE
40	14 ½P	Class 150	RS	UB	THD	SS	SS
41	212P	Class 200	RS	TB	THD	SS	SS
42	88	Class 200	RS	TB	THD	IB	Needle
43	382P	Class 300	RS	UB	THD	SS	SS
<b>Bronze Angle Valves</b>							
45	17TF	Class 150	RS	UB	THD	IB	PTFE
45	89	Class 200	RS	TB	THD	IB	Needle
46	384P	Class 300	RS	UB	THD	SS	SS
<b>Bronze Swing Check Valves</b>							
49	37	Class 125		SC	THD	IB	BRZ
49	41TF	Class 125		SC	THD	IB	PTFE
50	137	Class 150		SC	THD	IB	BRZ
51	1342	300 CWP		SC	SLD	IB	BRZ
52	141TF	Class 150		SC	THD	IB	PTFE
53	36	Class 200		SC	THD	IB	BRZ
54	1340	200 CWP		SC	SLD	IB	BRZ
55	76E	Class 300		SC	THD	IB	BRZ
<b>Bronze Lift Check Valves</b>							
56	29	Class 125		-	THD	IB	BRZ
57	27TF	Class 150		UC	THD	IB	PTFE
58	366E	Class 300		UC	THD	IB	BRZ

# Cross Reference



## BRONZE

### GLOBE

	Crane	NIBCO	Milwaukee
Class 125	1	T-211-B	502
Class 300 SS Trim	212P	T-276AP	593A

### GATE

Class 125 RS-Thread	428	T-111	148
Class 125 NRS-Thread	438	T-113	105
Class 125 RS-Solder	1330	S-111	149
Class 125 NRS-Solder	1320	S-113	115
Class 150 Union Bonnet	431UB	T-134	1151
Class 300 SS Trim	634E	T-174-SS	1184

### CHECK

Class 125 Thread	37	T-413-BY	509
Class 125 Solder	1340	S-413-B	1509
Class 300 Swing Check	76E	T-473-B	507
Class 300 Lift Check	366E	----	----

## IRON

	Crane	NIBCO	Milwaukee	Powell	Walworth
Class 125 NRS	461	F-619	F2882 A	1787	W719F
Class 125 OS&Y	465 ½	F-617-0	F2885 A	1793	W726F
Class 250 OS&Y	7.5E	F-667-0	F2894 A	1797	W786F

### GLOBE

Class 125	351	F-718-B	F2981 A	241	W906F
-----------	-----	---------	---------	-----	-------

### SWING CHECK

Class 125	373	F-918-B	F2974 A	559	W928F
-----------	-----	---------	---------	-----	-------

### STOP CHECK

Class 250 Straight-way Y-Pattern	28E	----	----	----	----
Class 250 Angle Y-Pattern	30E	F-869-B	----	----	----

Advanced manufacturing techniques and equipment, ongoing engineering research and product development, skilled craftsman, and over fourteen decades of experience in flow control are behind the quality and dependability built into every Crane product.

This catalog presents some of these products, namely: Crane's line of bronze gate, globe and check valves. The information is presented in a comprehensive manner and includes material, construction, rating, principal dimensions, and weight data.

## Hydrostatic and Shock Pressures

Crane valves are suitable for liquid working pressures specified on catalog pages only when used in hydraulic installations in which shock is absent or negligible. The sudden closure of a valve in a hydraulic system causes the body of liquid, which may be moving at a rate generally in excess of one foot per second, to stop instantaneously. As liquids are relatively incompressible, the sudden cessation of flow effects a rise in pressure considerably greater than the static working pressure. This pressure increase is termed "SHOCK" and may, in some cases, be sufficient to cause valves or piping to fail.

Pressure increase due to shock is not dependent upon the working pressure in the system but upon the velocity at which the liquid is flowing. This pressure surge, severely limits design velocities...a fact readily understandable if it is remembered that pressure rise resulting from arrest of flow may be as high as 60 psi for each foot per second initial velocity. For example, installations of 100 psi and 1000 psi working pressures, with the same initial velocity of 10 feet per second, will be subject to the same increase in pressure (approximately 600 psi) due to instantaneous closure of a valve.

Shock generally prevails in lines equipped with check or quick-closing valves, or in lines supplied by reciprocating pumps. It may also be produced, to a lesser degree, by rapid closure of gate and globe valves. Therefore, care should be exercised when choosing valves installed in liquid lines.

Where shock is likely to occur, the maximum shock pressure should be added to the working pressure of the line to determine working pressure products in the line...also, hydraulic installations should be equipped with air chambers or other types of shock absorbers to eliminate, as much as possible, increase due to shock.

## Testing

Bronze valves described in this section meet or exceed the MSS SP-80 specifications for testing.

## Materials

The selection of materials for components of Crane valves is based upon expert metallurgical, engineering, foundry and fabrication knowledge as well as on many years of usage experience. Considerations affecting materials of parts which come in contact with the conveyed fluid include pressure, temperature and chemical composition of the fluid. The materials of moving parts that are subject to rubbing contact are selected on the basis of their resistance to wear, corrosion, seizing or galling, and on their frictional characteristics.

Utilization of materials to their full capability is assured by the use of stress analysis techniques that include extensive laboratory testing as well as the application of analytical theory. Stress levels for all materials used are maintained within the levels established by applicable codes, standards and specifications.

## Illustrations & Weights

This catalog shows equivalent metric values to the customary imperial units. The "soft" conversion was arrived at by following MSS SP-86 guidelines.

**Illustrations** – Catalog illustrations are representative of a certain size of each line of product but do not necessarily represent all sizes in all details.

**Material & design** – We reserve the right to institute changes in materials, designs, dimensions and specifications without notice in keeping with our policy of continuing product development.

**Weights** – shown are approximate and are not guaranteed. They represent the average weight of Crane Valves products as made from patterns in use at time weights were compiled.

## Crane Copper Alloys

### CHEMICAL REQUIREMENTS (%) MECHANICAL PROPERTIES

	Copper	Tin	Lead	Iron	Nickel	Manganese	Aluminum	Zinc	Silicon	Other	Tensile Strength		Yield Strength		Elongation in 2" (50mm)
	Cu	Sn	Pb	Fe	Ni	Mn	Al	Zn	Si		ksi	MPa	ksi	MPa	(%)
<b>STEAM OR VALVE BRONZE CASTINGS</b> <span style="float: right;"><b>ASTM B61, C92200</b></span>															
Min.	86.0	5.5	1.0					3.0			34	235	16	110	24
Max.	90.0	6.5	2.0	0.25	1.0		0.005	5.0	0.005	0.05*					
<b>COMPOSITION BRONZE CASTINGS</b> <span style="float: right;"><b>ASTM B62, C83600</b></span>															
Min.	84.0	4.0	4.0					4.0			30	205	14	95	20
Max.	86.0	6.0	6.0	0.30	1.0		0.005	6.0	0.005	0.05*					
<b>COPPER-ZINC SILICON ALLOY ROD</b> <span style="float: right;"><b>ASTM B371, C69400</b></span>															
Min.	80.0							remainder	3.5		80	550	40	250	15
Max.	83.0		0.30	0.20					4.5						
<b>LEADED SEMI-RED BRASS</b> <span style="float: right;"><b>ASTM B584, C84400</b></span>															
Min.	78.0	2.3	6.0					7.0			29	200	13	90	18
Max.	82.0	3.5	8.0		1.0		0.005	10.0	0.005						
<b>SILICONE BRASS CASTINGS</b> <span style="float: right;"><b>ASTM B584, C87600</b></span>															
Min.	88.0							4.0	3.5		60	414	30	207	16
Max.			0.50					7.0	5.5						
<b>FREE CUTTING BRASS ROD/BAR</b> <span style="float: right;"><b>ASTM B16, C36000, H02</b></span>															
Min.	60.0		2.5					remainder			+	+	+	+	+
Max.	63.0		3.7	0.35						0.50**	+	+	+	+	+
<b>NAVAL BRASS ROD</b> <span style="float: right;"><b>ASTM B16, C48200, H02</b></span>															
Min.	59.0	0.5	0.4					remainder			+	+	+	+	+
Max.	62.0	1.0	1.0	0.15						0.10***	+	+	+	+	+
<b>ALUMINUM SILICONE BRONZE ROD</b> <span style="float: right;"><b>ASTM B150, C64200</b></span>															
Min.	87.5						6.3		1.5		+	+	+	+	+
Max.	92.5	0.20	0.05	0.30	0.25	0.10	7.6	0.50	2.2	0.50***	+	+	+	+	+
<b>LEADED RED BRASS CONTINUOUS CASTINGS</b> <span style="float: right;"><b>ASTM B505, C83600</b></span>															
Min.	84.0	4.0	4.0					4.0			36	248	19	131	15
Max.	86.0	6.0	6.0	0.30	1.0		0.005	6.0	0.005						
<b>BRASS PLATE/SHEET STRIP</b> <span style="float: right;"><b>ASTM B36, C26000, H04</b></span>															
Min.	68.5							remainder			71	489			
Max.	71.5		0.07	0.05							81	558			
<b>BRASS WIRE</b> <span style="float: right;"><b>ASTM B134, C26000, H02</b></span>															
Min.	68.5							remainder			57	395			
Max.	71.5		0.07	0.05							67	460			
<b>ALUMINUM SILICONE BRONZE FORGINGS</b> <span style="float: right;"><b>ASTM B283, C64200</b></span>															
Min.	88.7						6.3		1.5		+	+	+	+	+
Max.	90.1	0.20	0.05	0.30	0.25	0.10	7.6	0.50	2.2	0.15***	+	+	+	+	+
<b>COPPER SILICON ALLOY ROD/BAR</b> <span style="float: right;"><b>ASTM B98, C65100, H02</b></span>															
Min.	96.0								0.80		55	379	20	138	11
Max.			0.05	0.08		0.7		1.5	2.00						
<b>SEAMLESS COPPER WATER TUBE</b> <span style="float: right;"><b>ASTM B88, C12200</b></span>															
Min.	99.9										30	207			
Max.															

\* Also may include maximum of 0.05% phosphorus.

\*\* Maximum percent of elements permissible other than those indicated.

\*\*\* Also may include maximum of 0.15% arsenic.

+ Depends on diameter or thickness (surface to surface) of material: data on request.

## Introduction to Ratings

- A) Ratings for Class 125, 150, 200 and 300 bronze valves are indicated on page 6 in this catalog:
  - PSI Steam, Basic Rating; i.e., the nominal rated pressure of the valve.
  - PSI Cold Working Pressure; i.e., the maximum rated pressure of the valve at a temperature range of -20° to 150°F (-30° to 65°C).
- B) Ratings for Class 125 and 150 bronze valves equipped with non-metallic discs are indicated on the relevant catalog pages in this manner;
  - PSI Saturated Steam; where "Saturated Steam" is the maximum rated pressure of the valve at the corresponding temperature of saturated steam.
  - PSI Cold Working Pressure; where "Cold Working Pressure" is the maximum rated pressure of the valve at a temperature range of -20°F to 150°F (-30°C to 65°C).

The full range of allowable pressures and temperatures for these valves is determined by referring to the pressure-temperature charts shown on page 6.

- C) Ratings for bronze valves falling outside Class 125, 150, 200 and 300 are indicated in various ways on the relevant catalog pages. The full range of allowable pressures and temperatures for these valves is determined by referring to the relevant catalog page.

## General

All ratings represent the maximum allowable non-shock pressure at the indicated temperature. If the temperature is different from indicated, the allowable pressure may be interpolated.

## Rating Temperature

The operating temperature of the valve is considered the temperature of the media flowing through it. This temperature must not exceed the maximum allowable temperature as stated in the pressure-temperature chart on page 6.

The safe pressure-temperature rating of a solder joint piping system is dependent, not only on valve, fitting and tubing strength but also on the composition of the solder used for joints. It shall be the responsibility of the user to select a solder composition that is compatible with the service conditions.

The safe pressure-temperature rating of valves fitted with non-metallic discs (some Globe, Angle Valves and Check Valves) is dependent upon the composition of the disc material. It shall be the responsibility of the user to specify the service application. PTFE discs are suitable for a maximum service temperature of 400°F (200°C), nitrile composition discs are suitable for a maximum service temperature of 200°F (90°C).

## Adjusted Pressure/Temperature Ratings

Joints made of Copper Tube and Solder End Valves (pounds per square inch) Extracted from MSS SP-80

Solder used in joints	Service Temperature Degrees F	Water, including other noncorrosive liquids and gases			Saturated Steam (psig)
		Valve Sizes			Valves Sizes ¼" - 4"
		¼" - 1"	1 ¼" - 2"	2 ½" - 4"	
50-50 Tin-Lead (ASTM B-32, Alloy Grade 50-A)	100	200	175	150	-
	150	150	125	100	-
	200	100	90	75	-
	250	85	75	50	15
95-5 Tin-Antimony	100	500	400	300	-
	150	400	350	275	-
	200	300	250	200	-
	250	200	175	150	15

# Bronze Valves Ratings



## Pressure-Temperature Ratings

IMPERIAL UNITS						
Press. Class	125		150		200	300
End Conn.	THD	THD	FLG	THD	THD**	THD
Temp °F	PRESSURE – PSI NON-SHOCK					
	ASTM B-62			ASTM B-61		
-20 to 150	200	300	225	400	1000	600
200	185	270	210	375	920	560
250	170	240	195	350	830	525
300	155	210	180	325	740	490
350	140	180	165	300	650	450
400	–	–	–	275	560	410
406	125	150	150	–	–	–
450	120*	145*	–	250	480	375
500	–	–	–	225	390	340
550	–	–	–	200	300	300

METRIC UNITS						
Press. Class	125		150		200	300
End Conn.	THD	THD	FLG	THD	THD**	THD
Temp °C	PRESSURE – kPa NON-SHOCK					
	ASTM B-62			ASTM B-61		
-30 to 70	1380	2070	1550	2760	6890	4140
90	1280	1860	1450	2590	6340	3860
120	1170	1660	1340	2410	5720	3620
150	1070	1450	1240	2240	5100	3380
180	970	1240	1140	2070	4490	3100
200	–	–	–	1800	3860	2830
208	860	1030	1030	–	–	–
230	830*	1000*	–	1720	3310	2590
260	–	–	–	1550	2690	2340
290	–	–	–	1380	2070	2070

\* Some codes (i.e. ASME BPVC, Section 1) limit the rating temperatures of the indicated material to 406°F (208°C).

\*\* Alternative ratings for valve size 1/8" - 2" having threaded ends and union bonnet, when so indicated on the relevant catalogue pages.

## Technical Data: Flow Data (Cv Values)

The flow coefficient Cv expresses flow rate in usg per minute of water at 60°F, with 1.0 psi pressure drop across the valve.

Bronze Gate Valves	1/8"	1/4"	3/8"	1/2"	3/4"	1"	1 1/4"	1 1/2"	2"	2 1/2"	3"
All	–	8	8	16	36	60	90	140	270	470	680
Globe and Angle Valves											
17TF	–	1.6	3.1	5.1	9.2	16	28	39	66	–	–
382P	–	1.1	2.1	3.3	6.0	10	18	26	44	64	100
384P	–	1.5	3.0	4.9	9.0	15	27	38	64	–	–
1310	–	–	2.1	3.8	5.9	11	21	28	49	–	–
7TF, 14 1/2P, 212P	–	1.3	2.4	3.9	7.0	12	21	30	50	74	115
Check Valves											
29	–	1.3	2.5	4.1	7.6	13	23	31	54	78	125
27TF	–	0.9	1.8	3.0	5.4	9	16	22	39	–	–
366E	–	1.1	2.1	3.3	6.0	10	18	26	44	64	100
76E, 137, 1342, 141TF	–	2.3	4.3	7.2	13	22	39	56	92	135	215
Miscellaneous											
88, 89	0.3	0.6	1.1	1.9	3.4	–	–	–	–	–	–



## Light Industrial Series

### Quality and Performance in a Competitively Priced Bronze Line

The Crane line of Class 125 bronze valves is designed and priced to meet the needs of today's competitive business environment. This complete line of gate, globe and check valves conforms to the specifications set by the Manufacturers Standardization Society (MSS).\*

Perfectly suited for many industrial applications, these valves are manufactured to Crane exacting specifications and quality standards. Rigid quality control during and after manufacture is your assurance that you'll get a perfect Crane valve every time.

- Here's why Crane valves keep your costs down:
- Engineered to the design and quality standards of the Manufacturers Standardization Society (MSS)
  - Economically priced
  - Uncompromising quality
  - Distributor stocking to reduce your costs
  - Application assistance from trained representatives
  - Backed by Crane product performance warranty

\*All valves conform to MSS SP-80.  
 Thread ends conform to ASME B1.20.1  
 Solder joint ends conform to ASME B16.18.

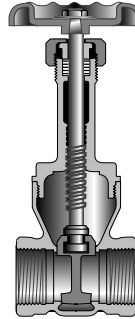

Rising Stem Gate  
Threaded

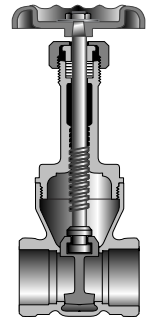

Rising Stem Gate  
Solder End

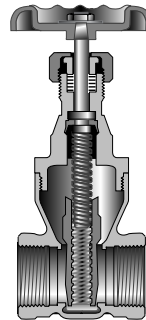

Non-Rising Stem Gate  
Threaded

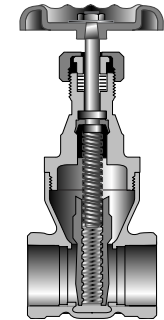

Non-Rising Stem Gate  
Solder End

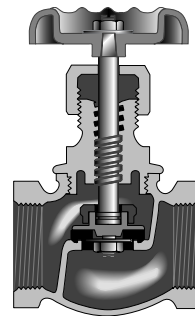

Globe, Screwed

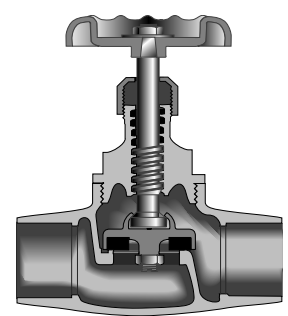

Globe, Solder Joint

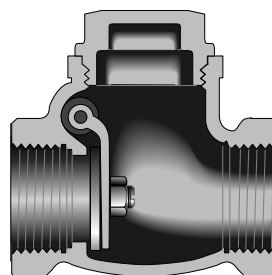

Check, Bronze Disc, Threaded

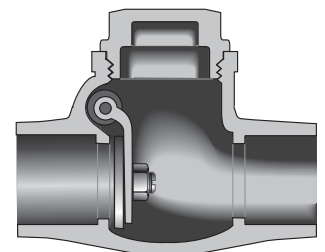

Check, Bronze Disc, Solder End

Figure 1700

# 1700 Series Bronze Gate Valve



**Class 125 • Inside Screw • Rising Stem • Solid Disc • Threaded Ends**

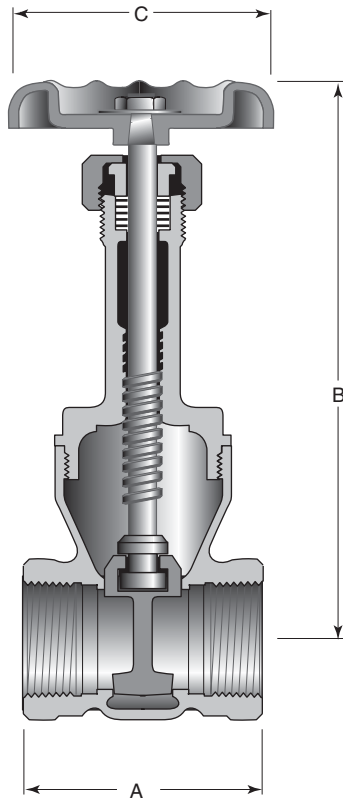

### Features

- Rising Stem
- Screwed Bonnet
- Threaded Ends
- Solid Wedge Disc
- Full Ports
- PTFE Packing

For more detailed features, refer to page 7.

### Figure 1700

#### Size Range:

¼" through 3"

#### Working Pressures Non-Shock:

125 psi Steam, Water, Oil or Gas

200 psi Cold Working Pressure

### Principal Parts & Materials

Part	Sizes	Material	ASTM
Body	All	Bronze	B62 C83600
Bonnet	All	Bronze	B62 C83600
Disc	All	Bronze	B62 C83600
Stem	All	Bronze	B584 C83600 or B21C C48200

### Dimensions and Weights

Inches (millimeters) - pounds (kilograms)

	¼ (6)	⅜ (10)	½ (15)	¾ (20)	1 (25)	1 ¼ (32)	1 ½ (40)	2 (50)	2 ½ (65)	3 (80)
A	1.65 (42)	1.65 (42)	1.97 (50)	2.00 (51)	2.36 (60)	2.68 (68)	2.78 (71)	3.07 (78)	4.00 (102)	4.57 (116)
B	4.33 (109)	4.33 (109)	4.29 (108)	4.88 (124)	5.98 (152)	6.81 (173)	7.80 (198)	9.53 (242)	11.18 (284)	12.83 (326)
C	1.97 (50)	1.97 (50)	2.17 (55)	2.36 (60)	2.76 (70)	3.15 (80)	3.54 (90)	3.54 (90)	4.72 (120)	5.12 (130)
WTS.	0.50 (0.02)	0.50 (0.02)	0.80 (0.36)	1.10 (0.50)	1.80 (0.81)	2.40 (1.08)	3.20 (1.44)	5.00 (2.25)	10.70 (4.83)	16.80 (7.59)



# 1700 Series Bronze Gate Valve

## Figure 1700S

**200 CWP • Inside Screw • Rising Stem • Solid Disc • Solder Ends**

### Figure 1700S

#### Size Range:

3/8" through 3"

#### Working Pressures Non-Shock:

200 psi Cold Working Pressure

### Features

- Rising Stem
- Screwed Bonnet
- Threaded Ends
- Solder Joint Ends
- Solid Wedge Disc
- Full Ports
- PTFE Packing
- ASME B16.18

For more detailed features, refer to page 7.

**Caution:** Before installing solder-joint valves, be sure solder or brazing alloy melting point is high enough to withstand line pressure, temperature conditions, and is compatible with fluid medium. See page 5 for adjusted pressure/temperature ratings.

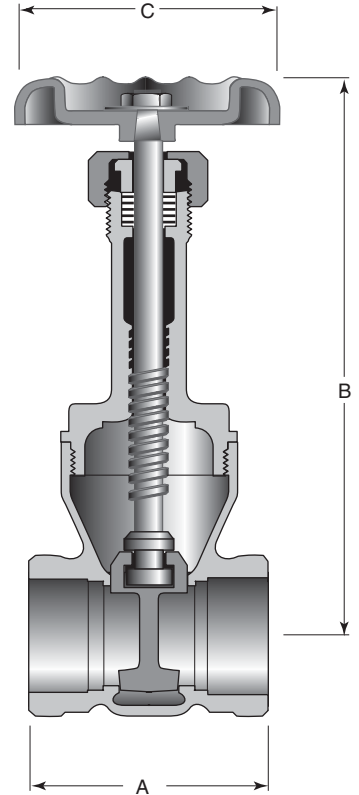

### Principal Parts & Materials

Part	Sizes	Material	ASTM
Body	All	Bronze	B62 C83600
Bonnet	All	Bronze	B16 C83600
Disc	All	Bronze	B16 C83600
Stem	All	Bronze	B584 C83600 or B21 C48200

### Dimensions and Weights

Inches (millimeters) - pounds (kilograms)

	3/8 (10)	1/2 (15)	3/4 (20)	1 (25)	1 1/4 (32)	1 1/2 (40)	2 (50)	2 1/2 (65)	3 (80)
A	1.57 (40)	1.89 (48)	2.36 (60)	2.80 (71)	3.15 (80)	3.46 (88)	4.09 (104)	4.72 (120)	5.35 (136)
B	3.51 (89)	4.29 (108)	4.88 (124)	5.98 (152)	6.81 (173)	7.80 (198)	9.53 (242)	11.18 (284)	12.83 (326)
C	2.12 (54)	2.12 (54)	2.40 (61)	2.64 (67)	3.27 (83)	3.27 (83)	3.74 (95)	4.41 (112)	5.12 (130)
WTS.	0.50 (0.22)	0.70 (0.32)	1.00 (0.45)	1.60 (0.72)	2.70 (1.22)	3.50 (1.58)	5.30 (2.39)	10.70 (4.83)	15.10 (6.82)

Figure 1701

# 1700 Series Bronze Gate Valve



**Class 125 • Inside Screw • Non-Rising Stem • Bronze Disc • Threaded Ends**

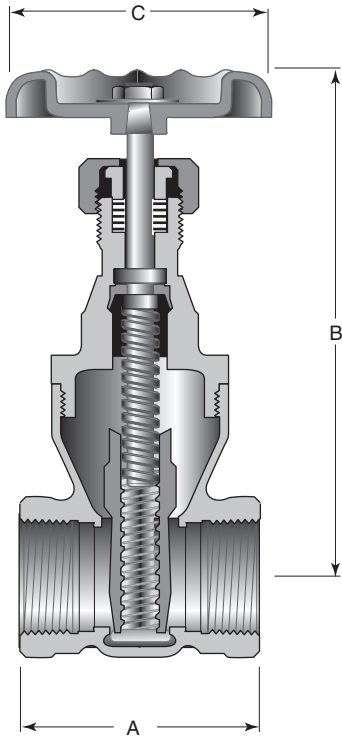

### Features

- Non-Rising Stem
- Solid Wedge Disc
- Threaded Ends
- One Piece Bonnet
- PTFE Packing
- Full Ports

For more detailed features, refer to page 7.

### Figure 1701

#### Size Range:

¼" through 3"

#### Working Pressures

##### Non-Shock:

125 psi Steam, Water, Oil or Gas

200 psi, Cold Working Pressure

### Principal Parts & Materials

Part	Sizes	Material	ASTM
Body	All	Bronze	B62 C83600
Bonnet	All	Bronze	B62 C83600
Disc	All	Bronze	B62 C83600
Stem	All	Bronze	B584 C83600 or B21 C48200

### Dimensions and Weights

Inches (millimeters) - pounds (kilograms)

	¼ (6)	⅜ (10)	½ (15)	¾ (20)	1 (25)	1 ¼ (32)	1 ½ (40)	2 (50)	2 ½ (65)	3 (80)
A	1.65 (41)	1.65 (41)	1.97 (50)	2.00 (50)	2.36 (60)	2.68 (68)	2.78 (71)	3.07 (80)	4.00 (101)	4.57 (116)
B	2.95 (75)	2.95 (75)	3.03 (77)	3.46 (88)	4.17 (106)	4.60 (117)	5.35 (136)	7.60 (193)	7.75 (197)	8.36 (212)
C	2.12 (54)	2.12 (54)	2.12 (54)	2.40 (61)	2.64 (67)	3.27 (83)	3.27 (83)	3.74 (95)	4.41 (112)	5.12 (130)
WTS.	0.50 (0.22)	0.50 (0.22)	0.70 (0.32)	1.00 (0.45)	1.50 (0.68)	2.10 (0.94)	2.70 (1.22)	4.50 (2.03)	10.60 (4.88)	15.80 (7.13)



# 1700 Series Bronze Gate Valve

## Figure 1701S

**200 CWP • Inside Screw • Non-Rising Stem • Bronze Disc • Solder Ends**

### Figure 1701S

#### Size Range:

3/8" through 3"

#### Working Pressures Non-Shock:

200 psi Cold Working Pressure

#### Features

- Non-Rising Stem
- Screwed One Piece Bonnet
- Solder Joint Ends
- PTFE Packing
- Full Ports
- ASME B16.18

For more detailed features, refer to page 7.

**Caution:** Before installing solder-joint valves, be sure solder or brazing alloy melting point is high enough to withstand line pressure, temperature conditions, and is compatible with fluid medium. See page 5 for adjusted pressure/temperature ratings.

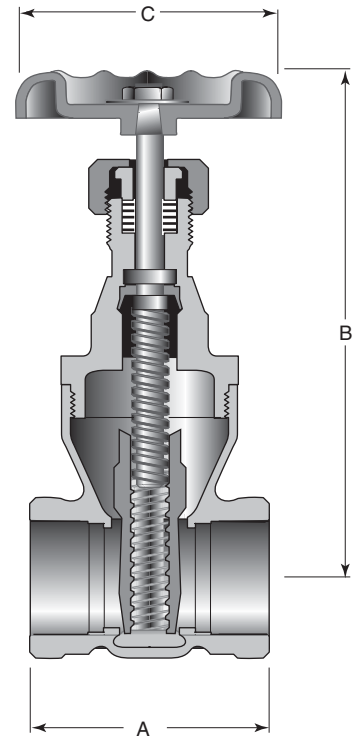

### Principal Parts & Materials

Part	Sizes	Material	ASTM
Body	All	Bronze	B62 C83600
Bonnet	All	Bronze	B62 C83600
Disc	All	Bronze	B62 C83600
Stem	All	Bronze	B584 C83600 or B21 C48200

### Dimensions and Weights

Inches (millimeters) - pounds (kilograms)

	3/8 (10)	1/2 (15)	3/4 (20)	1 (25)	1 1/4 (32)	1 1/2 (40)	2 (50)	2 1/2 (65)	3 (80)
A	1.57 (40)	1.89 (48)	2.36 (60)	2.80 (71)	3.15 (80)	3.76 (96)	4.09 (104)	4.72 (120)	5.35 (136)
B	2.75 (70)	3.03 (77)	3.46 (88)	4.17 (106)	4.80 (122)	5.85 (149)	7.00 (178)	7.75 (197)	8.36 (212)
C	2.12 (54)	2.12 (54)	2.40 (61)	2.64 (67)	3.27 (83)	3.27 (83)	3.74 (95)	4.41 (112)	5.12 (130)
WTS.	0.50 (0.22)	0.70 (0.32)	1.00 (0.45)	1.50 (0.68)	2.10 (0.94)	2.70 (1.22)	4.50 (2.03)	10.60 (4.88)	15.80 (7.13)

Figure 1702

# 1700 Series Bronze Globe Valve



**Class 125 • Inside Screw • Rising Stem • PTFE Disc • Threaded Ends**

### Features

- Rising Stem
- Bronze Disc
- Threaded Ends
- Internal Bronze Seat
- MSS SP-80, Type 1

For more detailed features, refer to page 7.

### Figure 1702

#### Size Range:

¼" through 2"

#### Working Pressures Non-Shock:

125 psi Steam, Basic Rating

200 psi Cold Working Pressure

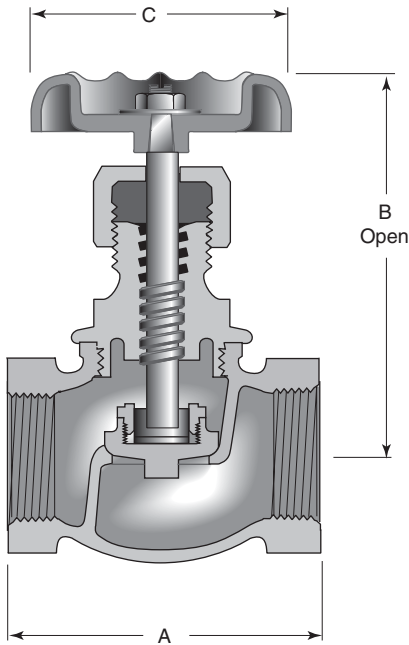

### Principal Parts & Materials

Part	Sizes	Material	ASTM
Body	All	Bronze	B62 alloy C83600
Bonnet	All	Bronze	B62 alloy C83600
Disc	All	Bronze	—
Stem	All	Bronze	B21 alloy C48200

### Dimensions and Weights

Inches (millimeters) - pounds (kilograms)

	¼ (6)	⅜ (10)	½ (15)	¾ (20)	1 (25)	1 ¼ (32)	1 ½ (40)	2 (50)
A	1.85 (47)	1.85 (47)	2.28 (58)	2.83 (72)	3.46 (88)	4.02 (102)	4.57 (116)	5.35 (136)
B	2.87 (73)	2.87 (73)	3.62 (92)	4.25 (108)	4.65 (118)	5.24 (133)	6.06 (154)	6.54 (166)
C	2.13 (54)	2.13 (54)	2.40 (61)	3.03 (77)	3.03 (77)	3.70 (94)	4.72 (120)	5.28 (134)
WTS.	0.70 (0.32)	0.70 (0.32)	0.96 (0.43)	1.43 (0.65)	2.15 (0.98)	3.20 (1.45)	4.18 (1.90)	4.78 (2.17)

**200 CWP • Inside Screw • Rising Stem • PTFE Disc • Solder Ends**

### Figure 1702S

#### Size Range:

3/8" through 2"

#### Working Pressures Non-Shock:

200 psi Cold Working Pressure

#### Features

- Recommended for 200 psi CWP
- Rising Stem
- Screwed Bonnet
- Solder Joint Ends
- Bronze Disc
- Internal Bronze Seat
- MSS SP-80, Type 2

For more detailed features, refer to page 7.

**Caution:** Before installing solder joint valves, be sure solder or brazing alloy melting point is high enough to withstand line pressure/temperature conditions, and is compatible with fluid medium. See page 5 for adjusted pressure/temperature ratings.

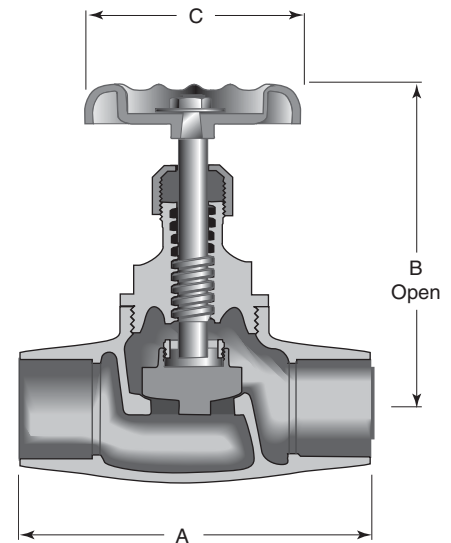

### Principal Parts & Materials

Part	Sizes	Material	ASTM
Body	All	Bronze	B62 alloy C83600
Bonnet	All	Bronze	B62 alloy C83600
Disc	All	Bronze	—
Stem	All	Bronze	B21 C48200

### Dimensions and Weights

Inches (millimeters) - pounds (kilograms)

	3/8 (10)	1/2 (15)	3/4 (20)	1 (25)	1 1/4 (32)	1 1/2 (40)	2 (50)
A	2.56 (65)	2.83 (72)	3.62 (92)	4.25 (108)	5.04 (128)	5.75 (146)	6.93 (176)
B	2.87 (73)	3.62 (92)	4.25 (108)	4.65 (118)	5.24 (133)	6.06 (154)	6.54 (166)
C	2.13 (54)	2.40 (61)	3.03 (77)	3.03 (77)	3.70 (94)	4.72 (120)	5.28 (134)
WTS.	0.61 (0.28)	0.88 (0.40)	1.36 (0.62)	2.15 (0.98)	3.25 (1.48)	4.30 (1.95)	4.30 (1.95)

**Class 125 • Inside Screw • Rising Stem • Brass Disc • Threaded Ends**

**Features**

- Recommended for 200 psi CWP
- Rising Stem
- Screwed Bonnet
- Threaded Ends
- PTFE Disc
- Internal Bronze Seat
- MSS SP-80, Type 2

**Figure 1703**

**Size Range:**

¼" through 2"

**Working Pressures Non-Shock:**

200 psi Cold Working Pressure

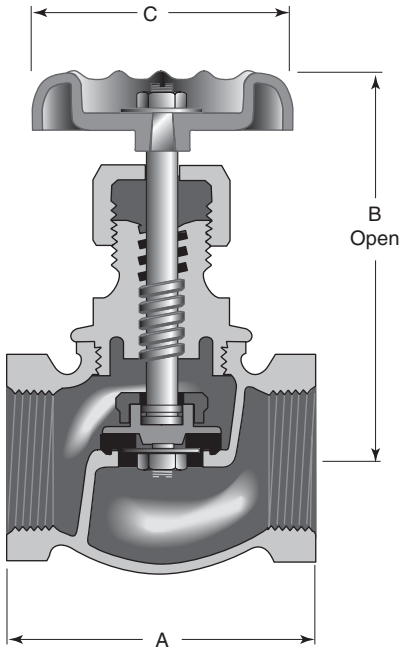

For more detailed features, refer to page 7.

**Principal Parts & Materials**

Part	Sizes	Material	ASTM
Body	All	Bronze	B62 alloy C83600
Bonnet	All	Bronze	B62 alloy C83600
Disc	All	PTFE	—
Stem	All	Bronze	B21 alloy C48200

**Dimensions and Weights**

Inches (millimeters) - pounds (kilograms)

	¼ (6)	⅜ (10)	½ (15)	¾ (20)	1 (25)	1 ¼ (32)	1 ½ (40)	2 (50)
A	1.85 (47)	1.85 (47)	2.28 (58)	2.83 (72)	3.46 (88)	4.02 (102)	4.57 (116)	5.35 (136)
B	2.87 (73)	2.87 (73)	3.62 (92)	4.25 (108)	4.65 (118)	5.24 (133)	6.06 (154)	6.54 (166)
C	2.13 (54)	2.13 (54)	2.40 (61)	3.03 (77)	3.03 (77)	3.70 (94)	4.72 (120)	5.28 (134)
WTS.	0.70 (0.32)	0.70 (0.32)	0.96 (0.43)	1.43 (0.65)	2.15 (0.98)	3.20 (1.45)	4.18 (1.90)	4.78 (2.17)



**200 CWP • Inside Screw • Rising Stem • Brass Disc • Solder Ends**

### Figure 1703S

#### Size Range:

3/8" through 2"

#### Working Pressures Non-Shock:

200 psi Cold Working Pressure

#### Features

- Recommended for 200 psi CWP
- Rising Stem
- Screwed Bonnet
- Solder Joint Ends
- PTFE Disc
- Internal Bronze Seat
- MSS SP-80, Type 2

For more detailed features, refer to page 7.

**Caution:** Before installing solder joint valves, be sure solder or brazing alloy melting point is high enough to withstand line pressure/temperature conditions, and is compatible with fluid medium. See page 5 for adjusted pressure/temperature ratings.

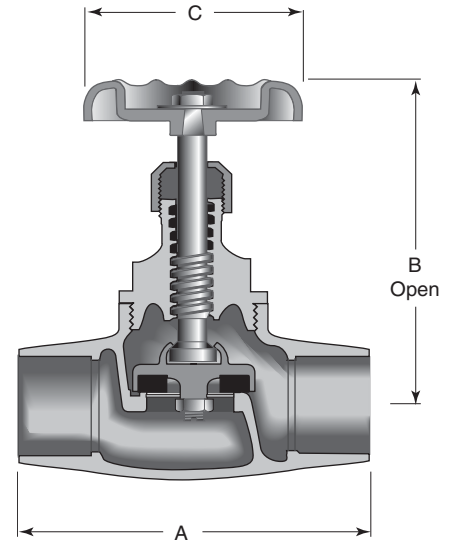

### Principal Parts & Materials

Part	Sizes	Material	ASTM
Body	All	Bronze	B62 alloy C83600
Bonnet	All	Bronze	B62 alloy C83600
Disc	All	PTFE	—
Stem	All	Bronze	B21 C48200

### Dimensions and Weights

Inches (millimeters) - pounds (kilograms)

	3/8 (10)	1/2 (15)	3/4 (20)	1 (25)	1 1/4 (32)	1 1/2 (40)	2 (50)
A	2.56 (65)	2.83 (72)	3.62 (92)	4.25 (108)	5.04 (128)	5.75 (146)	6.93 (176)
B	2.87 (73)	3.62 (92)	4.25 (108)	4.65 (118)	5.24 (133)	6.06 (154)	6.54 (166)
C	2.13 (54)	2.40 (61)	3.03 (77)	3.03 (77)	3.70 (94)	4.72 (120)	5.28 (134)
WTS.	0.61 (0.28)	0.88 (0.40)	1.36 (0.62)	2.15 (0.98)	3.25 (1.48)	4.30 (1.95)	4.30 (1.95)

Figure 1707

# 1700 Series Bronze Check Valve



**Class 125 • Bronze Cap • Brass/Bronze Disc • Threaded Ends**

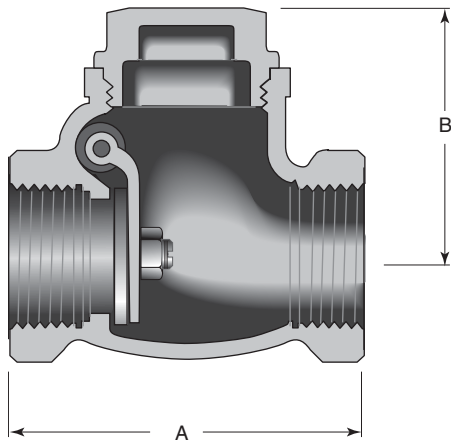

### Features

- T-Pattern Swing Check.
- Free-to-rotate bronze disc closes in a different position on the integral seat each time it operates.
- Always install with pressure under the disc in vertical or horizontal position. An arrow cast on the body indicates the correct direction of flow.
- Threaded Ends
- MSS SP-80, Type 3

For more detailed features, refer to page 7.

### Figure 1707

#### Size Range:

¼" through 3"

#### Working Pressures Non-Shock:

125 psi Steam, Basic Rating  
200 psi Cold Working Pressure

### Principal Parts & Materials

Part	Sizes	Material	ASTM
Body	All	Bronze	B62 C83600
Cap	All	Bronze	B16 C83600
Disc	¼" - ¾"	Bronze	B16 alloy 360
Disc	1" - 3"	Bronze	B62 C83600

### Dimensions and Weights

Inches (millimeters) - pounds (kilograms)

	¼ (6)	⅜ (10)	½ (15)	¾ (20)	1 (25)	1 ¼ (32)	1 ½ (40)	2 (50)	2 ½ (65)	3 (80)
A	2.12 (54)	2.12 (54)	2.60 (66)	2.76 (70)	3.27 (83)	3.78 (96)	4.25 (108)	5.04 (128)	6.30 (160)	7.08 (180)
B	1.50 (38)	1.50 (38)	1.77 (45)	1.93 (49)	2.28 (58)	2.56 (65)	2.86 (73)	3.50 (89)	4.25 (108)	4.84 (123)
WTS.	0.70 (0.32)	0.70 (0.32)	0.80 (0.36)	1.00 (0.45)	1.40 (0.63)	2.70 (1.22)	2.90 (1.31)	4.40 (1.98)	7.60 (3.42)	9.30 (4.19)



# 1700 Series Bronze Check Valve

## Figure 1707S

200 CWP • Bronze Cap • Brass/Bronze Disc • Solder Ends

### Figure 1707S

#### Size Range:

3/8" through 3"

#### Working Pressures Non-Shock:

200 psi Cold Working Pressure

### Features

- T-Pattern Swing Check.
- Free-to-rotate bronze disc closes in a different position on the integral seat each time it operates.
- Screwed Cap
- Solder Joint Ends
- Always install with pressure under the disc in vertical or horizontal position. An arrow cast on the body indicates the correct direction of flow.
- MSS SP-80, Type 3

For more detailed features, refer to page 7.

**Caution:** Before installing solder-joint valves, be sure the solder or brazing alloy is compatible with the fluid media and the alloy melting point is high enough to withstand the pressure and temperature conditions. See page 5 for adjusted pressure/temperature ratings.

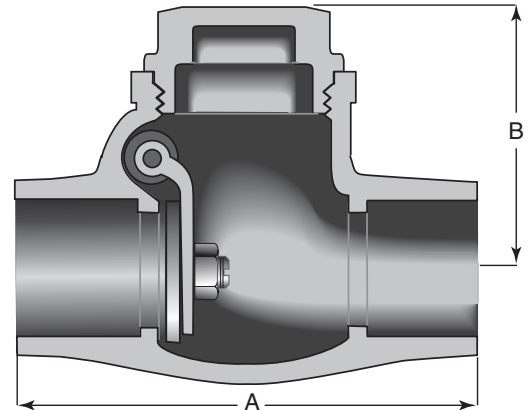

### Principal Parts & Materials

Part	Sizes	Material	ASTM
Body	All	Bronze	B62 C83600
Cap	All	Bronze	B16 C83600
Disc	3/8" - 3/4"	Bronze	B16 alloy 360
Disc	1" - 3"	Bronze	B62 C83600

### Dimensions and Weights

Inches (millimeters) - pounds (kilograms)

	3/8 (10)	1/2 (15)	3/4 (20)	1 (25)	1 1/4 (32)	1 1/2 (40)	2 (50)	2 1/2 (65)	3 (80)
A	2.28 (58)	2.60 (66)	3.23 (82)	3.86 (98)	4.49 (114)	5.12 (130)	6.14 (156)	7.25 (184)	8.07 (205)
B	1.50 (38)	1.77 (45)	1.93 (49)	2.28 (58)	2.56 (65)	2.86 (73)	3.50 (89)	4.25 (108)	4.84 (123)
WTS.	0.60 (0.27)	0.80 (0.36)	0.90 (0.41)	1.40 (0.63)	2.50 (1.13)	2.80 (1.26)	4.20 (1.90)	7.20 (3.25)	8.80 (3.97)

## Detailed Features

Crane gate valves offer the ultimate in dependable service wherever minimum pressure drop is important. They serve as efficient stop valves with fluid flow in either direction. Gate valves are best for services that require infrequent valve operation and where the disc is kept either in the fully opened or fully closed position.

### FEATURES AND BENEFITS

The Crane gate valve design provides the following benefits to the user:

- Streamlined design has eliminated sharp body contours while providing maximum strength without added weight.
- Body design increases the resistance to shock and distortion.
- Body design reinforces seat against the wedging action to the disc.
- Wide-faced hexagon ends provide a firm wrench grip and help to prevent damage to the valve.

Other design features have been incorporated into our gate valves, making Crane one of the most trusted valve manufacturers in the myriad of industries we serve.

### BONNET OPTIONS

#### Screwed Bonnets

Screwed bonnets have optimum sized hexagons for easy and positive wrench grip. To ensure a leak tight joint and to provide high unit loading with minimal torque, the flat bonnet sealing face contacts on the 5 degree inclined face of the body.

#### One Piece Bonnets

One piece bonnets are compact in design, maintain a tight joint and allow easy dismantle.

#### Union Bonnets

Union bonnets are supplied with optimum sized hexagon shaped, high tensile bronze rings to provide a leak-tight joint for maximum security under pressure. It also simplifies inspection of the valve interior.

### STEM OPTIONS

#### Rising Stems

Rising stems provide positive indication of the disc position.

#### Non-Rising Stems

Valves provided with non-rising stems are ideal for applications where space is limited.

### WEDGE OPTIONS

#### Solid Wedge Discs

The single piece design is ideal for a variety of applications, particularly for conditions of severe turbulence. Discs are reversible in the body and machined to provide for smooth operation. Accurate guiding throughout its travel prevents disc-to-seat contact until the point of closure, thus minimizing seat wear.

### VALVE SEAT COMPONENTS

#### Back Seat

All Crane gate valves are provided with a back seat which can be used as an indication of valve position. For normal operation, the stem should be backed off so that the back seat is not in contact. This permits the stem packing to assume its intended sealing function. In the unlikely event of stem packing leakage, the back seat can be used to stop the leakage until the packing can be replaced. Packing replacement should not be undertaken while the valve is under pressure as it represents a safety hazard.

#### Stainless Steel Seat Rings

Stainless steel (AISI 410) seat rings provide high resistance to wear, temperature, galling and scoring. Normal seating wear is absorbed by the disc which can be easily replaced.

### END OPTIONS

#### Flanged Ends

Valves supplied with flanged ends conform to ASME B16.24 (Class 150). Flanges are plain faced with two V-Shaped concentric grooves between the port and bolt holes.

#### Threaded Ends

Valves supplied with threaded ends conform to ASME B1.20.1

#### Solder Joint Ends

Valves supplied with solder joint ends comply with ASME B16.18.

### PACKING

#### Packing

Graphite composition packing provides a tight seal.

### HEAT DISPENSING HANDWHEELS

#### Standard Handwheel

The open rim, multi-rib design provides easy manual operation. Handles are sized to provide adequate torque to operate the valve without the aid of levers, hickies or wrenches.

### MARKING

#### Identification Plate

Each valve is identified and marked in accordance with industry standard MSS SP-25. The identification plate is located under the handwheel nut permitting easy field reference.

### INDUSTRY STANDARDS AND APPROVALS

Depending on design, the following specifications and standard are also applicable to Crane gate valves. See individual catalogs for specific standard/specification compliance.

#### Design Specifications for Bronze Gate Valves

- MSS SP-80
- ASME B16.10, Class 125 for face-to-face dimensions
- ASME B16.24, Class 150 for flanged valves
- ASME B16.118 for solder joint ends

#### Approvals:

- ULC Listed

**CAUTION:** Gate valves are not recommended for throttling service since flow against a partially opened disc may cause vibration or chattering, resulting in damage to the seating surfaces of the valve.

NON-RISING STEM GATE VALVE

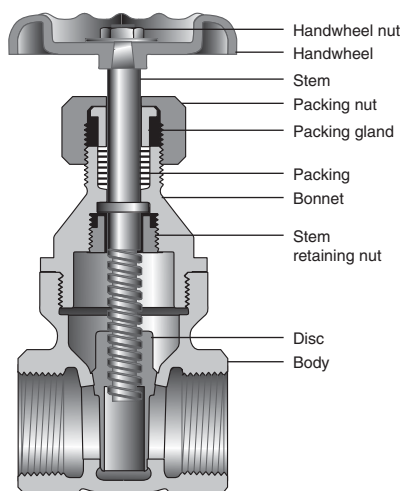

RISING STEM GATE VALVE

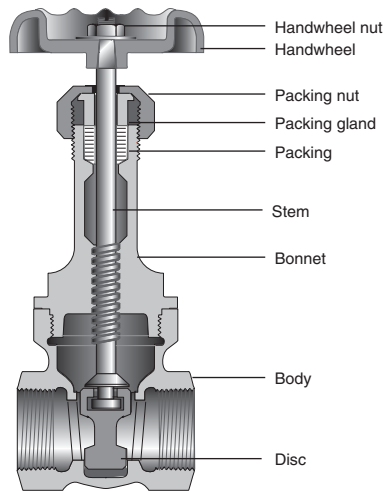

UNION BONNET GATE VALVE

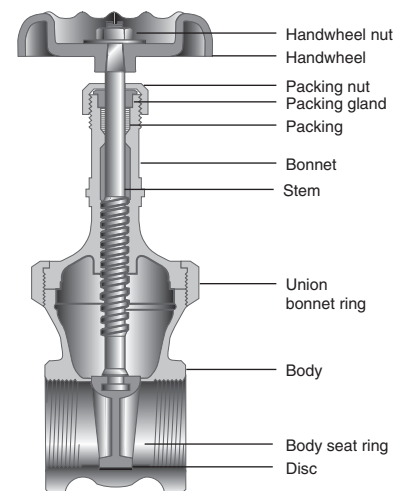

### Class 125 • Threaded Bonnet • Rising Stem • Threaded Ends

Figure 428

**Size Range:**

¼" through 3"

**Working Pressures Non-Shock:**

125 psi Steam, Basic Rating

200 psi Cold Working Pressure

**Features**

- Rising Stem
- Screwed Bonnet
- Solid Wedge Disc
- Back Seat
- Full Ports
- Integral Bronze Seat
- MSS SP-80, Type 2

For more detailed features, refer to page 18.

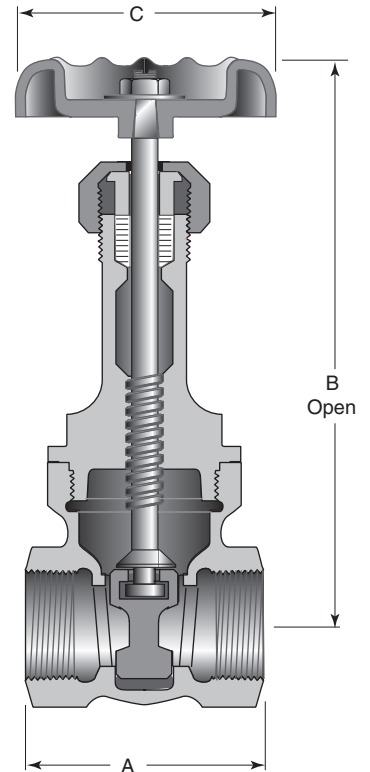

### Principal Parts & Materials

Part	Size	Material	ASTM
Body & bonnet	All	Bronze	B62 alloy C83600
Disc	All	Bronze	B62 alloy C83600
Stem	¼"-2"	Bronze	B505 alloy C83600
Stem	2 ½"-3"	Bronze	B371 alloy C69400

### Dimensions and Weights

Inches (millimeters) - pounds (kilograms)

	¼ (6)	⅜ (10)	½ (15)	¾ (20)	1 (25)	1 ¼ (32)	1 ½ (40)	2 (50)	2 ½ (65)	3 (80)
A	1.65 (42)	1.65 (42)	2.04 (52)	2.15 (55)	2.47 (63)	2.77 (70)	2.85 (72)	3.25 (83)	4.24 (108)	4.61 (117)
B	4.92 (125)	4.92 (125)	5.07 (129)	6.24 (158)	7.43 (189)	8.58 (218)	9.67 (246)	11.81 (300)	14.77 (375)	16.63 (422)
C	2.13 (54)	2.13 (54)	2.57 (65)	2.57 (65)	2.75 (70)	3.08 (78)	3.64 (92)	3.65 (93)	5.24 (133)	5.24 (133)
WTS.	0.05 (0.22)	0.05 (0.22)	0.09 (0.41)	1.40 (0.61)	2.00 (0.91)	3.10 (1.41)	4.20 (1.91)	6.70 (3.02)	12.60 (5.69)	19.00 (8.60)

**Class 125 • Union Bonnet • Rising Stem • Threaded Ends**

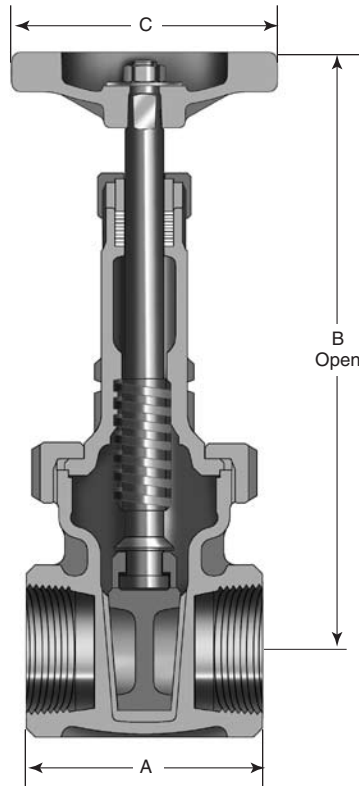

**Features**

- Rising Stem
- Union Bonnet
- Solid Wedge Disc
- Back Seat
- Full Ports
- Integral Bronze Seat
- MSS SP-80, Type 2

For more detailed features, refer to page 18.

**Figure 428UB**

**Size Range:**

¼" through 3"

**Working Pressures Non-Shock:**

125 psi Steam, Basic Rating

200 psi Cold Working Pressure

**Principal Parts & Materials**

Part	Size	Material	ASTM
Body & bonnet	All	Bronze	B62 alloy C83600
Disc	All	Bronze	B62 alloy C83600
Stem	¼"-2"	Bronze	B62 alloy C83600
Stem	2 ½"-3"	Cu-Si Bronze	B371 alloy C69400

**Dimensions and Weights**

Inches (millimeters) - pounds (kilograms)

	¼ (6)	⅜ (10)	½ (15)	¾ (20)	1 (25)	1 ¼ (32)	1 ½ (40)	2 (50)	2 ½ (65)	3 (80)
A	1.81 (46)	1.81 (46)	1.98 (51)	2.14 (55)	2.46 (63)	2.77 (71)	2.85 (73)	3.25 (83)	4.25 (108)	4.59 (117)
B	4.96 (126)	4.96 (126)	5.07 (129)	6.25 (159)	7.44 (189)	8.62 (219)	9.68 (246)	11.85 (301)	14.53 (369)	16.39 (416)
C	2.25 (57)	2.25 (57)	2.75 (70)	2.75 (70)	2.75 (70)	3.25 (83)	4.00 (102)	4.00 (102)	4.75 (121)	5.50 (140)
WTS.	0.90 (0.41)	0.90 (0.41)	1.50 (0.67)	2.30 (1.03)	3.40 (1.54)	5.10 (2.31)	7.20 (3.28)	11.90 (5.40)	13.10 (5.94)	20.10 (9.12)

**Class 125 • Threaded Bonnet • Non-Rising Stem • Threaded Ends**

### Figure 438

**Size Range:**

¼" through 3"

**Working Pressures Non-Shock:**

125 psi Steam, Basic Rating

200 psi Cold Working Pressure

### Features

- Non-Rising Stem
- Screwed Bonnet
- Threaded Ends
- Solid Wedge Disc
- Full Ports
- Integral Bronze Seat
- Back seat
- MSS SP-80, Type 1

For more detailed features, refer to page 18.

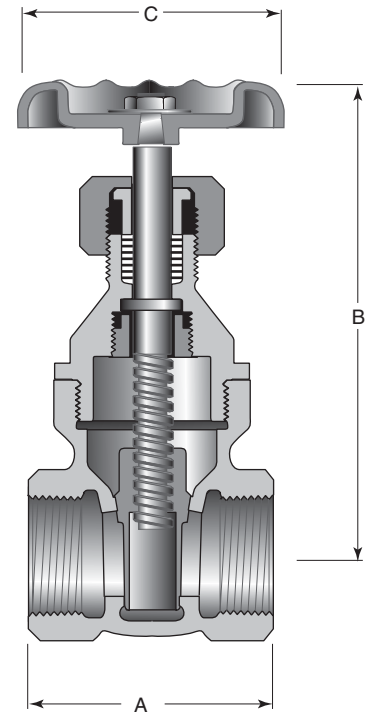

### Principal Parts & Materials

Part	Size	Material	ASTM
Body & bonnet	All	Bronze	B62 alloy C83600
Disc	All	Bronze	B62 alloy C83600
Stem	¼"–2"	Bronze	B505 alloy C83600
Stem	2 ½"–3"	Bronze	B371 alloy C69400

### Dimensions and Weights

Inches (millimeters) - pounds (kilograms)

	¼ (6)	⅜ (10)	½ (15)	¾ (20)	1 (25)	1 ¼ (32)	1 ½ (40)	2 (50)	2 ½ (65)	3 (80)
A	1.65 (42)	1.65 (42)	2.02 (51)	2.14 (54)	2.46 (63)	2.77 (70)	2.85 (72)	3.24 (82)	4.20 (107)	4.65 (118)
B	2.95 (75)	2.95 (75)	3.23 (82)	4.18 (106)	4.73 (120)	5.62 (143)	6.53 (166)	7.35 (187)	9.20 (234)	10.13 (257)
C	2.56 (65)	2.56 (65)	2.06 (52)	2.56 (65)	2.75 (70)	3.08 (78)	3.62 (92)	4.00 (102)	5.22 (133)	5.22 (133)
WTS.	0.5 (0.22)	0.5 (0.22)	0.7 (0.32)	1.3 (0.56)	1.8 (0.79)	3.0 (1.34)	3.7 (1.66)	5.7 (2.59)	12.4 (5.60)	17.7 (8.00)

## 300 CWP • Threaded Bonnet • Non-Rising Stem • Solder Ends

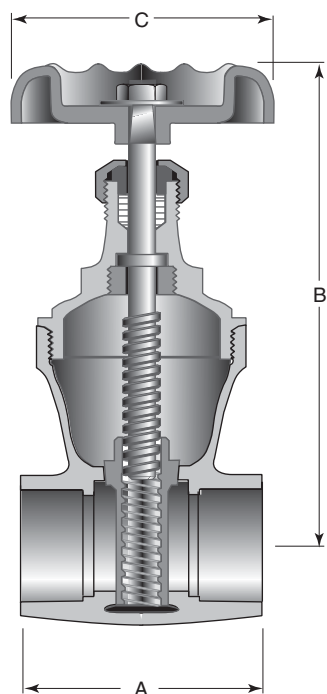

## Features

- Non-Rising Stem
- Screwed Bonnet
- Solid Wedge Disc
- Solder joint ends
- Full Ports
- Back Seat
- Integral Bronze Seat
- MSS SP-80, Type 1

For more detailed features, refer to page 18.

**CAUTION:** Before installing solder joint valves, be sure solder or brazing alloy melting point is high enough to withstand line pressure temperature conditions and is compatible with fluid medium. See page 5 for adjusted pressure/temperature ratings.

## Figure 1324

## Size Range:

½" through 3"

## Working Pressures Non-Shock:

300 psi Cold Working Pressure

## Principal Parts &amp; Materials

Part	Size	Material	ASTM
Body & bonnet	All	Bronze	B62 alloy C83600
Disc	All	Bronze	B62 alloy C83600
Stem	½"–2"	Bronze	B505 alloy C83600
Stem	2 ½"–3"	Bronze	B371 alloy C69400

## Dimensions and Weights

Inches (millimeters) - pounds (kilograms)

	½ (15)	¾ (20)	1 (25)	1 ¼ (32)	1 ½ (40)	2 (50)	2 ½ (65)	3 (80)
A	1.88 (48)	2.41 (61)	2.91 (74)	3.11 (79)	3.47 (88)	4.12 (105)	5.00 (127)	6.00 (152)
B	3.24 (82)	4.22 (107)	5.04 (128)	5.64 (143)	6.48 (165)	7.39 (188)	9.20 (234)	10.08 (256)
C	2.08 (53)	2.57 (65)	2.97 (75)	3.08 (78)	3.64 (92)	4.00 (102)	5.24 (133)	5.24 (133)
WTS.	0.70 (0.29)	1.20 (0.52)	2.40 (1.09)	2.50 (1.13)	3.60 (1.63)	5.40 (2.45)	12.00 (5.44)	16.80 (7.62)



**Class 150 • Threaded Bonnet • Rising Stem • Threaded Ends**

**Figure 431**

Solid Wedge Disc

**Size Range:**

¼" through 3"

**Working Pressures Non-Shock:**

150 psi Steam, Basic Rating

300 psi Cold Working Pressure

**Features**

- Rising Stem
- Screwed Bonnet
- Threaded Ends
- Full Ports
- Back Seat
- Integral Bronze Seat
- MSS SP-80, Type 2

For more detailed features, refer to page 18.

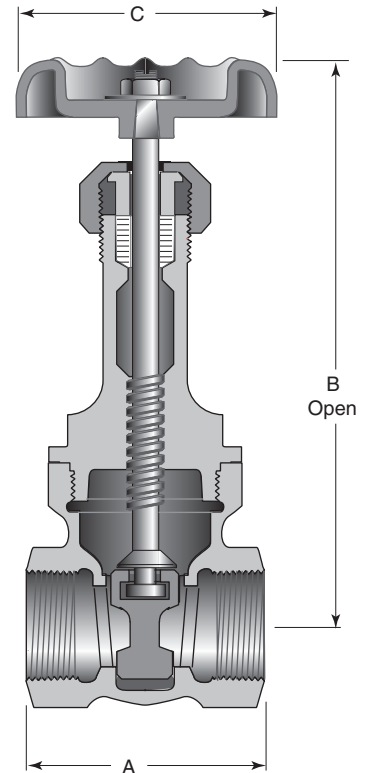

**Principal Parts & Materials**

Part	Size	Material	ASTM
Body & bonnet	All	Bronze	B62 alloy C83600
Disc	All	Bronze	B62 alloy C83600
Stem	½"-2"	Bronze	B505 alloy C83600
Stem	¼"- <sup>3</sup> / <sub>8</sub> ", 2 ½"-3"	Bronze	B371 alloy C69400

**Dimensions and Weights**

Inches (millimeters) - pounds (kilograms)

	¼ (6)	⅜ (10)	½ (15)	¾ (20)	1 (25)	1 ¼ (32)	1 ½ (40)	2 (50)	2 ½ (65)	3 (80)
A	1.80 (46)	1.68 (43)	2.02 (51)	2.14 (54)	2.46 (62)	2.77 (70)	2.85 (72)	3.25 (83)	4.25 (108)	4.61 (117)
B	4.78 (121)	4.93 (125)	4.98 (127)	6.28 (160)	7.44 (189)	8.49 (216)	9.77 (248)	11.98 (304)	14.93 (379)	16.83 (427)
C	1.77 (45)	2.05 (52)	2.08 (53)	2.57 (65)	2.76 (70)	3.08 (78)	3.65 (93)	4.06 (103)	5.26 (134)	5.26 (134)
WTS.	0.80 (0.36)	0.80 (0.36)	0.90 (0.39)	1.40 (0.64)	2.00 (0.91)	3.30 (1.47)	4.20 (1.91)	6.70 (3.02)	12.80 (5.81)	18.50 (8.39)

**Class 150 • Union Bonnet • Rising Stem • Threaded Ends**

**Features**

- Rising Stem
- Union Bonnet
- Solid Wedge Disc
- Threaded Ends
- Full Ports
- Back Seat
- Integral Bronze Seat
- MSS SP-80, Type 2

For more detailed features, refer to page 18.

**Figure 431UB**

**Size Range:**

¼" through 3"

**Working Pressures Non-Shock:**

150 psi Steam, Basic Rating

300 Cold Working Pressure

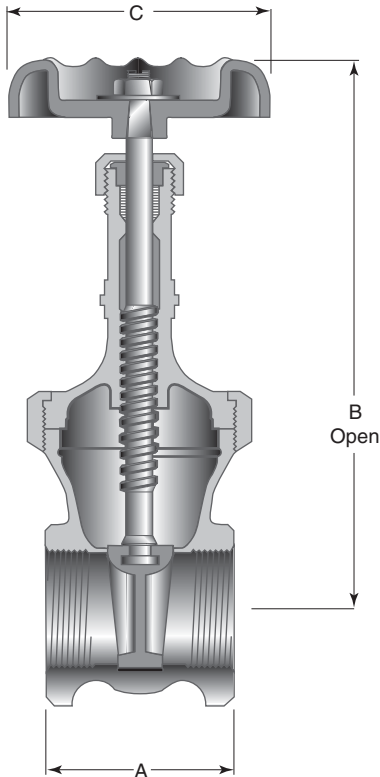

**Principal Parts & Materials**

Part	Size	Material	ASTM
Body & Union bonnet	All	Bronze	B62 alloy C83600
Disc	All	Bronze	B62 alloy C83600
Stem	¼"-2"	Bronze	B505 alloy C83600
Stem	2 ½"-3"	Bronze	B371 alloy C69400

**Dimensions and Weights**

Inches (millimeters) - pounds (kilograms)

	¼ (6)	⅜ (10)	½ (15)	¾ (20)	1 (25)	1 ¼ (32)	1 ½ (40)	2 (50)	2 ½ (65)	3 (80)
A	1.64 (42)	1.64 (42)	2.03 (52)	2.14 (54)	2.46 (62)	2.78 (71)	2.85 (72)	3.25 (83)	4.24 (108)	4.63 (118)
B	4.84 (123)	4.84 (123)	4.98 (126)	6.29 (160)	7.39 (188)	8.57 (218)	9.68 (246)	11.89 (302)	14.86 (377)	17.02 (432)
C	2.06 (52)	2.06 (52)	2.08 (53)	2.57 (65)	2.76 (70)	3.08 (78)	3.64 (92)	4.00 (102)	5.24 (133)	5.24 (133)
WTS.	0.90 (0.41)	0.90 (0.39)	0.90 (0.41)	1.50 (0.68)	2.40 (1.07)	3.60 (1.63)	4.90 (2.22)	7.50 (3.40)	14.00 (6.35)	20.70 (9.37)

### Class 150 • Threaded Bonnet • Non-Rising Stem • Threaded Ends

Figure 437

**Size Range:**

¼" through 3"

**Working Pressures Non-Shock:**

150 psi Steam, Basic Rating

300 psi Cold Working Pressure

**Features**

- Non-Rising Stem
- Screwed Bonnet
- Solid Wedge Disc
- Threaded Ends
- Full Ports
- Back Seat
- Integral Bronze Seat
- MSS SP-80, Type 1

For more detailed features, refer to page 18.

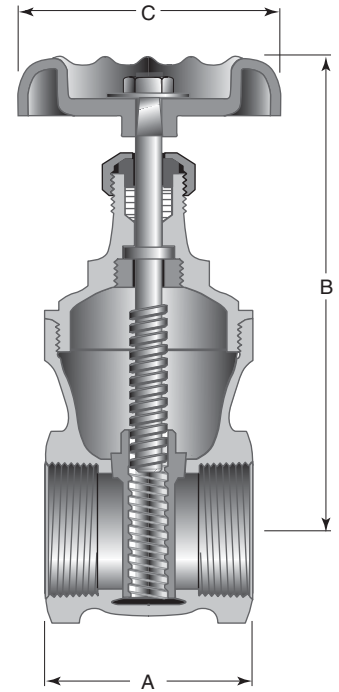

### Principal Parts & Materials

Part	Size	Material	ASTM
Body & bonnet	All	Bronze	B62 alloy C83600
Disc	All	Bronze	B62 alloy C83600
Stem	½"-2"	Bronze	B505 alloy C83600
Stem	¼"-¾", 2 ½"-3"	Bronze	B371 alloy C69400

### Dimensions and Weights

Inches (millimeters) - pounds (kilograms)

	¼ (6)	⅜ (10)	½ (15)	¾ (20)	1 (25)	1 ¼ (32)	1 ½ (40)	2 (50)	2 ½ (65)	3 (80)
A	1.64 (42)	1.65 (42)	2.02 (51)	2.14 (54)	2.46 (63)	2.77 (70)	2.85 (72)	3.24 (82)	4.20 (107)	4.65 (118)
B	3.65 (98)	3.70 (94)	3.23 (82)	4.18 (106)	4.73 (120)	5.62 (143)	6.53 (166)	7.35 (187)	9.20 (234)	10.13 (257)
C	2.06 (52)	2.06 (52)	2.06 (52)	2.56 (65)	2.75 (70)	3.08 (78)	3.62 (92)	4.00 (102)	5.22 (133)	5.22 (133)
WTS.	0.80 (0.34)	0.80 (0.34)	0.80 (0.32)	1.30 (0.56)	1.80 (0.79)	3.00 (1.34)	3.70 (1.66)	5.70 (2.59)	12.40 (5.60)	17.70 (8.00)

**Class 150 • Threaded Bonnet • Non-Rising Stem • Flanged Ends**

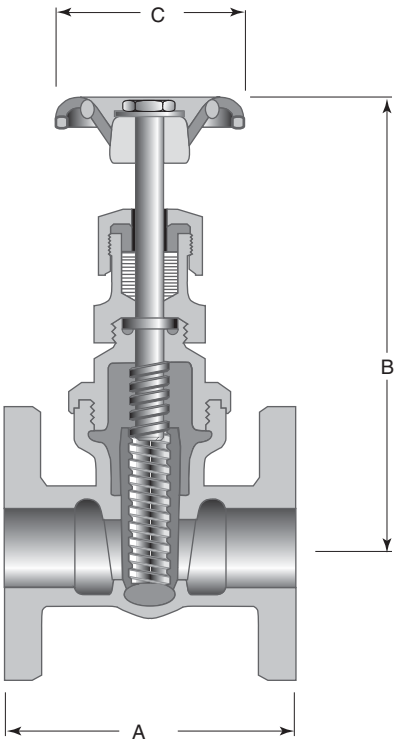

### Features

- Screwed Bonnet
- Solid Wedge Disc
- Flanged Ends are plain faced with two V-shaped concentric grooves between the port and bolt holes.
- Full Ports
- Integral Bronze Seat
- MSS SP-80, Type 2

For more detailed features, refer to page 18.

### Figure 429

#### Size Range:

1" through 3"

#### Working Pressures Non-Shock:

150 psi Steam, Basic Rating

225 psi Cold Working Pressure

### Principal Parts & Materials

Part	Material	ASTM
Body & bonnet	Bronze	B62 alloy C83600
Disc	Bronze	B62 alloy C83600
Stem	Bronze	B371 alloy C69400

### Dimensions and Weights

Inches (millimeters) - pounds (kilograms)

	1 (25)	1 ¼ (32)	1 ½ (40)	2 (50)	2 ½ (65)	3 (80)
A	3.94 (100)	4.33 (110)	4.72 (120)	5.32 (135)	6.50 (165)	7.28 (185)
B	4.88 (1.24)	5.71 (145)	6.50 (165)	7.44 (189)	9.19 (233)	10.38 (264)
C	2.56 (66)	2.75 (70)	3.06 (78)	3.62 (92)	4.06 (103)	4.75 (121)
WTS.	5.7 (2.6)	6.3 (2.85)	9.00 (4.06)	12.20 (5.51)	18.50 (8.36)	25.50 (11.52)

**200 CWP • Threaded Bonnet • Non-Rising Stem • Solder Ends**

### Figure 1320

**Size Range:**

½" through 3"

**Working Pressures Non-Shock:**

150 psi Steam, Basic Rating

200 psi Cold Working Pressure

### Features

- Screwed Bonnet
- Solid Wedge Disc
- Solder Joint Ends
- Full Ports
- Integral Bronze Seat
- MSS SP-80, Type 1

For more detailed features, refer to page 18.

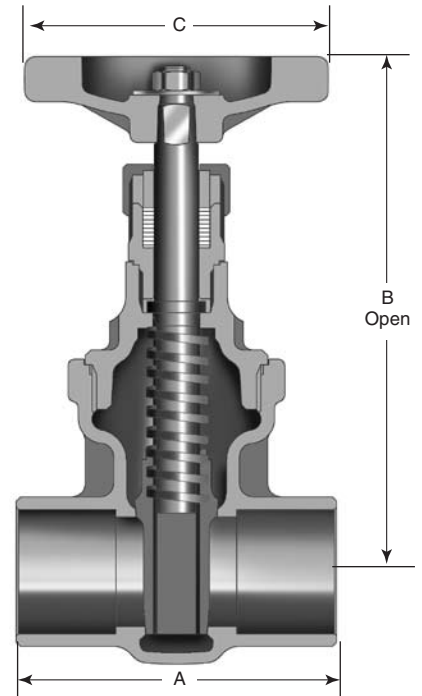

### Principal Parts & Materials

Part	Size	Material	ASTM
Body & bonnet	All	Bronze	B62 alloy C83600
Disc	All	Bronze	B62 alloy C83600
Stem	½"–2"	Bronze	B62 alloy C83600
Stem	2 ½"–3"	Cu-Si Bronze	B371 alloy C69400

### Dimensions and Weights

Inches (millimeters) - pounds (kilograms)

	½ (15)	¾ (20)	1 (25)	1 ¼ (32)	1 ½ (40)	2 (50)	2 ½ (65)	3 (80)
A	1.90 (49)	2.44 (62)	2.91 (74)	3.15 (80)	3.51 (89)	4.17 (106)	4.91 (125)	5.50 (140)
B	3.23 (82)	3.74 (95)	4.64 (118)	5.67 (144)	6.53 (166)	7.36 (187)	9.26 (235)	9.89 (251)
C	2.75 (70)	2.75 (70)	2.75 (70)	3.25 (83)	4.00 (102)	4.00 (102)	4.75 (121)	5.50 (140)
WTS.	0.90 (0.31)	1.40 (0.49)	2.10 (0.77)	2.80 (1.08)	4.40 (1.54)	6.50 (2.45)	12.30 (5.22)	18.30 (7.39)

**200 CWP • Threaded Bonnet • Rising Stem • Solder Ends**

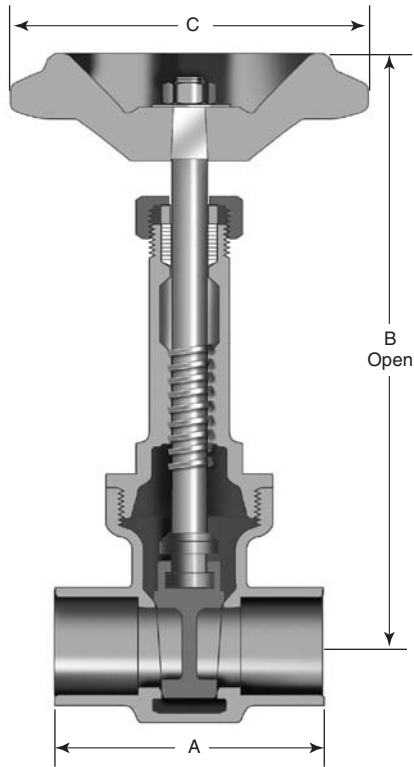

### Features

- Rising Stem
- Threaded Ends
- Solid Wedge Disc
- Full Ports
- Back Seat
- Integral Bronze Seat
- MSS SP-80, Type 2

For more detailed features, refer to page 18.

### Figure 1330

**Size Range:**

½" through 3"

**Working Pressures Non-Shock:**

200 psi Cold Working Pressure

### Principal Parts & Materials

Part	Material	ASTM
Body & bonnet	Bronze	B62 alloy 83600
Disc	Bronze	B62 alloy 83600
Stem	Bronze	B62 alloy 83600

### Dimensions and Weights

Inches (millimeters) - pounds (kilograms)

	½	¾	1	1 ¼	1 ½	2	2 ½	3
	(15)	(20)	(25)	(32)	(40)	(50)	(65)	(80)
A	1.89 (48)	2.36 (60)	2.79 (71)	3.15 (80)	3.46 (88)	4.09 (104)	4.72 (120)	5.35 (136)
B	4.98 (126)	5.69 (145)	7.21 (183)	8.11 (206)	9.46 (240)	12.06 (306)	13.75 (349)	16.10 (409)
C	2.56 (65)	2.75 (70)	2.75 (70)	3.27 (83)	3.27 (83)	3.66 (93)	4.41 (112)	5.19 (132)
WTS.	0.70 (0.32)	1.00 (0.45)	1.60 (0.72)	2.70 (1.22)	3.50 (1.58)	5.30 (2.39)	10.70 (4.83)	15.10 (6.82)

**Class 200 • Union Bonnet • Rising Stem • Threaded Ends**

**Figure 422**

**Size Range:**

¼" through 3"

**Working Pressures Non-Shock:**

200 psi Steam, Basic Rating

400 psi Cold Working Pressure

**Features**

- Rising Stem
- Union Bonnet
- Solid Wedge Disc
- Threaded Ends
- Full Ports
- Back Seat
- MSS SP-80, Type 2

For more detailed features, refer to page 18.

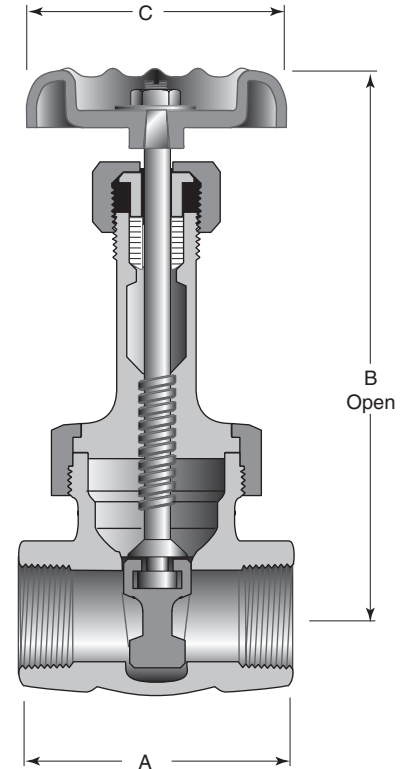

**Principal Parts & Materials**

Part	Sizes	Material	ASTM
Body & union bonnet	All	Bronze	B61 alloy C92200
Disc	All	Bronze	B61 alloy C92200
Stem	¼" - 2"	Bronze	B505 alloy 83600
Stem	2 ½" - 3	Bronze	B371 alloy 69400

**Dimensions and Weights**

Inches (millimeters) - pounds (kilograms)

	¼ (6)	⅜ (10)	½ (15)	¾ (20)	1 (25)	1 ¼ (32)	1 ½ (40)	2 (50)	2 ½ (65)	3 (80)
A	1.64 (42)	1.64 (42)	2.02 (51)	2.14 (54)	2.46 (62)	2.79 (71)	2.85 (72)	3.25 (83)	4.20 (107)	4.63 (118)
B	4.84 (123)	4.84 (123)	5.06 (129)	6.29 (160)	7.39 (188)	8.56 (217)	9.68 (246)	11.89 (302)	14.80 (376)	16.86 (428)
C	2.06 (52)	2.06 (52)	2.57 (65)	2.57 (65)	2.76 (70)	3.64 (92)	3.64 (92)	4.00 (102)	5.24 (133)	5.50 (140)
WTS.	0.9 (0.41)	0.9 (0.39)	0.9 (0.41)	1.50 (0.68)	2.40 (1.07)	3.60 (1.63)	4.90 (2.22)	7.50 (3.40)	14.00 (6.31)	21.20 (9.60)

**Class 200 • Union Bonnet • Rising Stem • Stainless Steel Seats • Threaded**

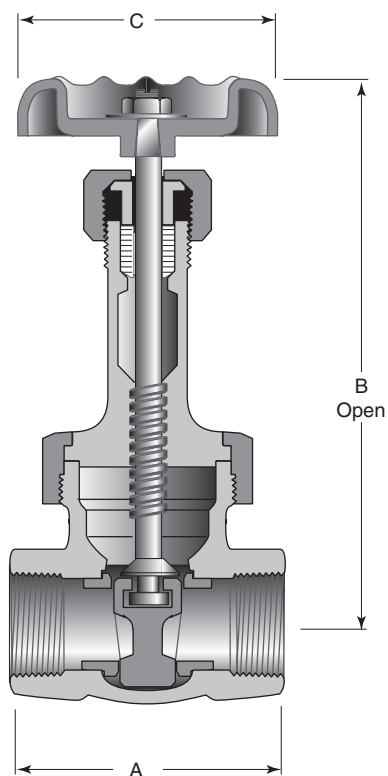

### Features

- Rising Stem
- Union Bonnet
- Bolted Bonnet (2 1/2" to 3")
- Threaded Ends
- Solid Wedge Disc
- Full Ports
- Back Seat
- 410 Stainless Steel Seat Rings
- MSS SP-80, Type 2

For more detailed features, refer to page 18.

### Figure 424

#### Size Range:

1/4" through 3"

#### Working Pressures Non-Shock:

200 psi Steam, Basic Rating

400 psi Cold Working Pressure

### Principal Parts & Dimensions

Part	Material	ASTM
Body, bonnet & union ring	Bronze	B61 alloy C92200
Disc	Bronze	B61 alloy C92200
Seat ring	410 Stainless Steel	A276 S41000
Stem	Bronze	B371 alloy C69400

### Dimensions and Weights

Inches (millimeters) - pounds (kilograms)

	1/4 (6)	3/8 (10)	1/2 (15)	3/4 (20)	1 (25)	1 1/4 (32)	1 1/2 (40)	2 (50)	2 1/2 (65)	3 (80)
A	2.03 (52)	2.11 (54)	2.44 (62)	2.61 (66)	3.04 (77)	3.34 (85)	3.67 (93)	3.96 (101)	4.60 (117)	5.67 (144)
B	4.81 (122)	4.85 (123)	5.37 (136)	6.71 (170)	7.77 (197)	9.06 (230)	10.32 (262)	12.50 (318)	14.58 (370)	16.33 (415)
C	2.10 (53)	2.10 (53)	2.48 (63)	2.65 (67)	2.97 (75)	3.25 (83)	3.66 (93)	4.61 (117)	5.25 (133)	6.97 (177)
WTS.	1.00 (0.45)	1.00 (0.45)	1.50 (0.68)	2.10 (0.95)	3.30 (1.50)	5.00 (2.27)	6.00 (2.72)	10.40 (4.72)	19.60 (8.89)	35.30 (16.01)



### Class 200 • Union Bonnet • Non-Rising Stem • Stainless Steel Seats

#### Figure 426

##### Size Range:

¼" through 2"

##### Working Pressures Non-Shock:

200 psi Steam, Basic Rating

400 psi Cold Working Pressure

#### Features

- Non-Rising Stem
- Solid Wedge Disc
- Threaded Ends
- Union Bonnet
- Full Ports
- Back Seat
- 410 Stainless Steel Seat Ring
- MSS SP-80, Type I

For more detailed features, refer to page 18.

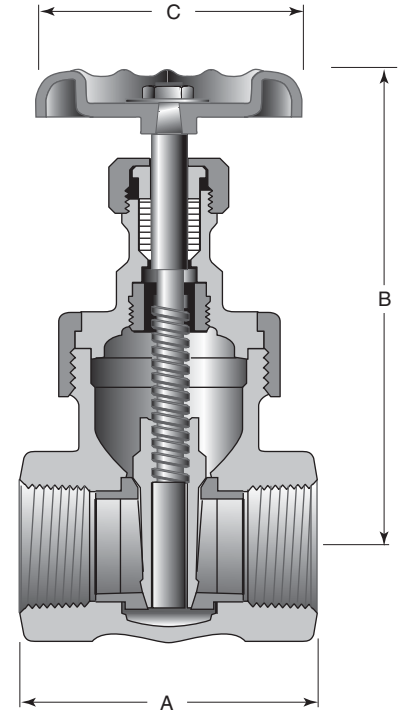

#### Principal Parts & Materials

Part	Material	ASTM
Body & bonnet	Bronze	B61 alloy C92200
Disc	Bronze	B61 alloy C92200
Seat ring	410 Stainless Steel	A276 S41000
Stem	Bronze	B371 alloy C69400

#### Dimensions and Weights

Inches (millimeters) - pounds (kilograms)

	¼ (6)	⅜ (10)	½ (15)	¾ (20)	1 (25)	1 ¼ (32)	1 ½ (40)	2 (50)
A	2.03 (52)	2.13 (54)	2.47 (63)	2.60 (66)	3.05 (77)	3.38 (86)	3.68 (93)	3.96 (101)
B	3.60 (91)	3.51 (89)	3.86 (98)	4.51 (115)	5.05 (128)	5.88 (149)	6.65 (169)	7.76 (197)
C	2.05 (52)	2.13 (54)	2.47 (63)	2.63 (67)	2.96 (75)	3.25 (83)	3.68 (93)	4.59 (117)
WTS.	0.90 (0.41)	0.90 (0.41)	1.40 (0.64)	1.90 (0.86)	3.10 (1.41)	5.00 (2.27)	5.80 (2.63)	10.20 (4.63)

**Class 300 • Union Bonnet • Rising Stem • Threaded Ends**

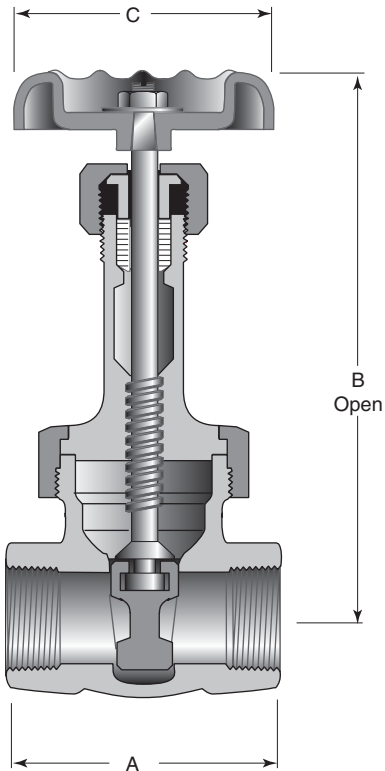

**Features**

- Rising Stem
- Union Bonnet
- Threaded Ends
- Solid Wedge Disc
- Full Ports
- Back Seat
- MSS SP-80, Type 2

For more detailed features, refer to page 18.

**Figure 622E**

**Size Range:**

¼" through 3"

**Working Pressures Non-Shock:**

300 psi Steam, Basic Rating

1000 psi Cold Working Pressure

¼" - 3" (6mm - 80mm)

**Principal Parts & Materials**

Part	Sizes	Material	ASTM
Body & bonnet	All	Bronze	B61 alloy C92200
Disc	All	Bronze	B61 alloy C92200
Stem	¼" - 3"	Bronze	B371 alloy 694

**Dimensions and Weights**

Inches (millimeters) - pounds (kilograms)

	¼	⅜	½	¾	1	1 ¼	1 ½	2	2 ½	3
	(6)	(10)	(15)	(20)	(25)	(32)	(40)	(50)	(65)	(80)
A	1.64 (42)	1.64 (42)	2.04 (52)	2.14 (54)	2.47 (63)	3.08 (78)	3.21 (82)	3.39 (86)	4.25 (108)	4.59 (117)
B	4.77 (121)	4.77 (121)	5.48 (139)	6.68 (170)	7.81 (199)	9.26 (235)	10.26 (261)	12.36 (313)	14.53 (369)	16.39 (416)
C	1.75 (44)	1.75 (44)	2.13 (54)	2.71 (69)	3.03 (77)	3.03 (77)	3.72 (94)	4.72 (120)	5.28 (134)	5.28 (134)
WTS.	0.70 (0.32)	0.70 (0.32)	1.20 (0.50)	1.80 (0.80)	3.00 (1.40)	4.00 (1.80)	5.30 (2.40)	8.70 (3.90)	13.1 (6.0)	20.1 (9.2)

**Class 300 • Union Bonnet • Rising Stem • Stainless Steel Seats • Threaded**

Figure 634E

**Size Range:**

¼" through 3"

**Working Pressures Non-Shock:**

300 psi Steam, Basic Rating

1000 psi Cold Working Pressure

¼" to 2" - (6mm - 50mm)

600 psi Cold Working Pressure

2 ½" to 3" - (65mm - 80mm)

**Features**

- Rising Stem
- Union Bonnet
- Bolted Bonnet (2 ½" to 3")
- Solid Wedge Disc
- Threaded Ends
- Full Ports
- Back Seat
- 410 Stainless Steel Seat Rings
- MSS SP-80, Type 2

For more detailed features, refer to page 18.

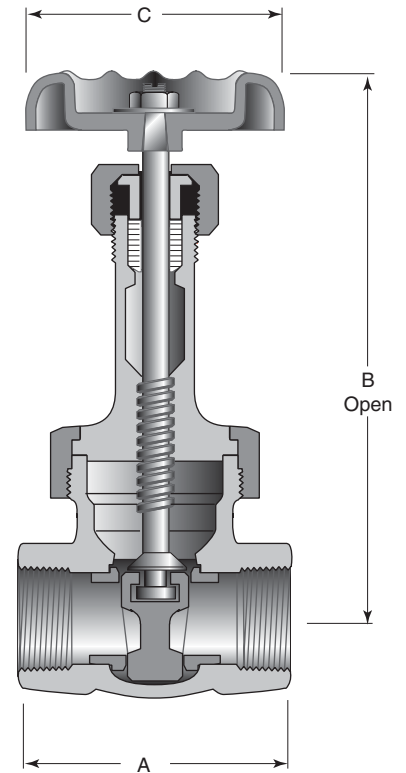

**Principal Parts & Materials**

Part	Sizes	Material	ASTM
Body & bonnet	All	Bronze	B61 alloy C92200
Disc	All	Bronze	B61 alloy C92200
Seat ring	All	410 Stainless Steel	A276 S41000
Stem	All	Bronze	B371 alloy C69400

**Dimensions and Weights**

Inches (millimeters) - pounds (kilograms)

	¼ (6)	⅜ (10)	½ (15)	¾ (20)	1 (25)	1 ¼ (32)	1 ½ (40)	2 (50)	2 ½ (65)	3 (80)
A	2.03 (52)	2.13 (54)	2.42 (61)	2.61 (66)	3.06 (78)	3.35 (85)	3.69 (94)	3.96 (101)	4.60 (117)	5.63 (143)
B	4.86 (123)	4.86 (123)	5.40 (137)	6.60 (168)	7.91 (201)	9.32 (237)	10.45 (265)	13.38 (340)	14.12 (359)	16.78 (426)
C	2.25 (57)	2.25 (57)	2.25 (57)	2.75 (70)	2.75 (70)	3.25 (83)	4.00 (102)	4.00 (102)	4.75 (121)	7.00 (178)
WTS.	.85 (0.39)	.94 (0.43)	1.44 (0.65)	2.06 (0.94)	3.34 (1.52)	4.81 (2.18)	6.13 (2.78)	10.44 (4.74)	20.50 (9.31)	44.00 (19.95)

**Class 300 • Union Bonnet • Non-Rising Stem • Stainless Steel Seats**

### Features

- Non-Rising Stem
- Union Bonnet
- Solid Wedge Disc
- Threaded Ends
- Full Ports
- Back Seat
- 410 Stainless Steel Seat Rings
- MSS SP-80, Type I

For more detailed features, refer to page 18.

### Figure 636E

#### Size Range:

¼" through 2"

#### Working Pressures Non-Shock:

300 psi Steam, Basic Rating

1000 psi Cold Working Pressure

¼" to 2" - (6mm - 50mm)

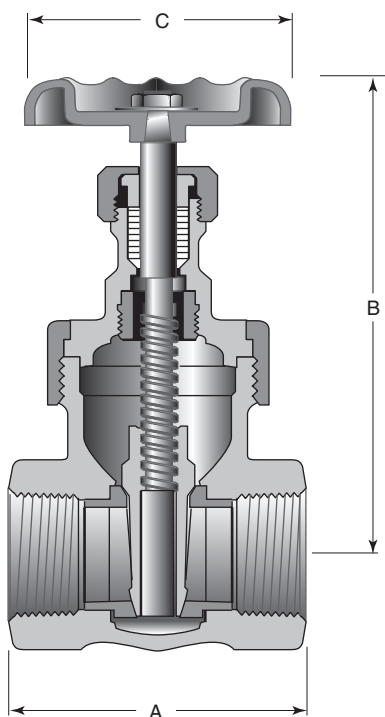

### Principal Parts & Materials

Part	Material	ASTM
Body & bonnet	Bronze	B61 alloy C92200
Disc	Bronze	B61 alloy C92200
Seat ring	410 Stainless Steel	A276 S41000
Stem	Bronze	B371 alloy C69400

### Dimensions and Weights

Inches (millimeters) - pounds (kilograms)

	¼ (6)	⅜ (10)	½ (15)	¾ (20)	1 (25)	1 ¼ (32)	1 ½ (40)	2 (50)
A	2.03 (52)	2.13 (54)	2.47 (63)	2.60 (66)	3.05 (77)	3.38 (86)	3.68 (93)	3.96 (101)
B	3.60 (91)	3.51 (89)	3.86 (98)	4.51 (115)	5.05 (128)	5.88 (149)	6.65 (169)	7.76 (197)
C	2.05 (52)	2.13 (54)	2.47 (63)	2.63 (67)	2.96 (75)	3.25 (83)	3.68 (93)	4.59 (117)
WTS.	0.90 (0.41)	0.90 (0.41)	1.40 (0.64)	1.90 (0.86)	3.20 (1.45)	4.80 (2.18)	5.90 (2.68)	10.20 (4.63)

## Detailed Features

Crane Globe and Angle Valves are highly efficient for regulating flow because disc and seat design provide flow characteristics with proportionate relationships between valve lift and flow rate. This assures accurate regulated flow control. The additional advantage of an angle valve is that it provides a 90° turn in piping so fewer joints are required and make-up time and labor are reduced.

Each valve in this section is classified by its pressure rating. All valves designated as Class 125, 150, 200 or 300 comply with MSS SP-80 Standard Practice.

**Body** is made of bronze conforming to requirements of ASTM B62 or B61 depending on valve pressure class. Like all parts, bodies are designed to withstand high internal pressures and line strains... and are proportioned to assure a high safety factor under recommended working pressures.

**Body Seat Ring** is made from high grade material especially selected to perform dependably in the services for which the valve is recommended.

**Disc Stem Connection** in all valves is designed to hold the disc securely while allowing it to rotate. The result is true, positive sealing with no damage to sealing surfaces.

**Conventional Metal Disc** has a relatively narrow contact with the body seal. It is recommended for a variety of general services but not for close throttling.

**PTFE Disc** has the same basic construction as the fully guided metal disc except that the disc is inserted in a disc holder. These pliable discs assure tight sealing and simplify valve maintenance. The PTFE disc is recommended for 150 psi saturated steam, 300 psi maximum non-shock cold water, oil, gas, and air.

**Metal Plug Type Disc** is conically shaped. This design is universally accepted for rigorous service. Because of the wide sealing surfaces, it is not easily harmed by foreign matter or wire drawing. Crane uses stainless steel in this design.

**Stem** is made from high grade materials especially selected to perform dependably in the services for which the valve is recommended.

**Multiple Choice Seating** are engineered for optimum performance on a wide range of services; renewable PTFE disc, regrind bronze seating, regrind and renewable plug type disc and seat ring in hardened 450 BHN, AISI 420 stainless steel. Hardened stainless steel discs and seat rings are performance proven. Needle or plug type seating provides graduated closure for throttling service. PTFE discs assure tight shut-off and are easy to change.

**Cylindrical Shaped Body** is the strongest and most successful design for withstanding internal pressures and line strains. The extra rigidity imparted by this shape prevents body distortion from line strain.

**Large End Hexagons** add additional body reinforcement and provide large surfaces for positive wrench grip.

**Screwed Bonnet** has generous optimum-sized hexagons for easy and positive wrench grip. For an easily remade and positively leak-tight joint, the flat bonnet seating face contacts a 5° inclined face of the body, providing high unit loading with relatively low torques.

**Union Bonnet** Where service conditions require, generous union bonnet rings facilitate frequent dismantling and reassembly of the bonnets and reinforce the bonnet joint to ensure a tight joint and maximum security under pressure.

**Solder Joint Valves** conform to ASME B16.18 specification for depth and diameter.

**Heat Dispersing Handwheel** Open rim, rounded multi-rib design provides a comfortable, positive grip. Handles are sized to provide adequate torque to operate the valve without the aid of levers, hickys or wrenches.

**End Threads** are precision cut in accordance to ASME B1.20.1.

**Strong Stem Threads** are precision machined to ensure ease of operation and long service.

**Crane Bronze Globe and Angle** valves have an identification plate which indicates the valve catalog number and the type of disc. Located under the handwheel nut, it permits easy and accurate field reference.

All valves are clearly identified and marked to MSS SP-25 specification.

For pressure-temperature ratings and Cv values, see pages 5-6.

NEEDLE VALVE

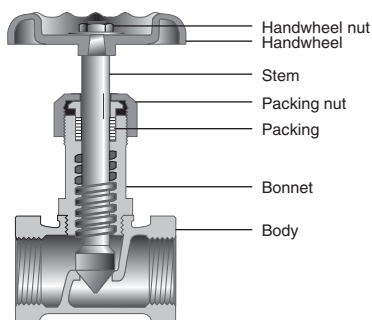

GLOBE VALVE WITH PTFE DISC

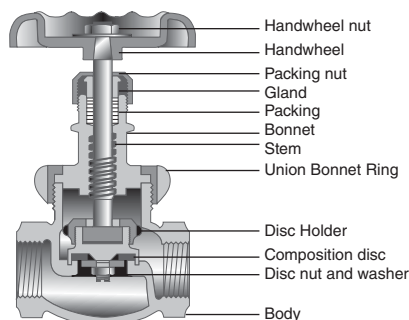

GLOBE VALVE WITH METAL TYPE PLUG DISC

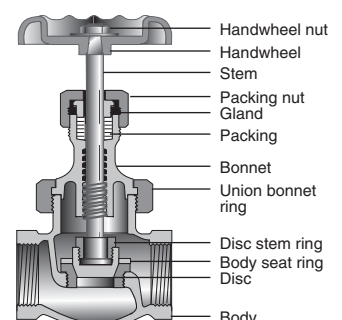
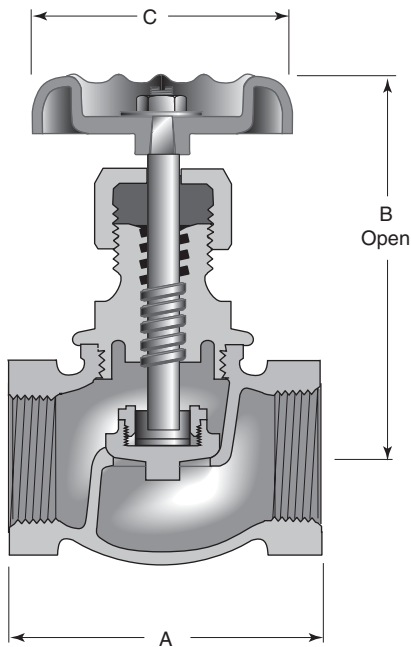

Figure 1

# Bronze Globe Valve



**Class 125 • Threaded Bonnet • Brass/Bronze Disc • Threaded Ends**



### Features

- Heavier and more rugged than is usual with Class 125 valves.
- Threaded Ends
- Integral Bronze Seat
- Back Seat
- MSS SP-80, Type 1

For more detailed features, refer to page 35.

### Figure 1

#### Size Range:

¼" through 2"

#### Working Pressures Non-Shock:

125 psi Steam, Basic Rating

200 psi Cold Working Pressure

### Principal Parts & Materials

Part	Sizes	Material	ASTM
Body	All	Bronze	B62 alloy C83600
Bonnet	All	Bronze	B62 alloy C83600
Disc	All	Bronze	B61 alloy C92200
Stem	All	Bronze	B371 alloy C69400

### Dimensions and Weights

Inches (millimeters) - pounds (kilograms)

	¼ (6)	½ (15)	¾ (20)	¾ (10)	1 (25)	1 ¼ (32)	1 ½ (40)	2 (50)
A	1.92 (49)	1.95 (50)	2.57 (65)	2.99 (76)	3.51 (89)	3.88 (99)	4.67 (119)	5.75 (146)
B	3.73 (95)	3.63 (92)	3.41 (87)	4.37 (111)	4.92 (125)	5.24 (133)	5.75 (146)	6.56 (167)
C	1.96 (50)	1.92 (49)	2.14 (54)	2.98 (76)	3.03 (77)	3.70 (94)	4.63 (118)	5.25 (133)
WTS.	0.70 (0.29)	0.60 (0.27)	1.10 (0.48)	2.00 (0.88)	2.80 (1.27)	4.20 (1.88)	6.30 (2.84)	9.80 (4.45)

**Class 125 • Threaded Bonnet • PTFE Disc • Threaded Ends**

### Figure 5TF

**Size Range:**

3/8" through 2"

**Working Pressures Non-Shock:**

125 psi Steam, Basic Rating

200 psi Cold Working Pressure

### Features

- PTFE Disc
- Threaded Ends
- Internal Bronze Seat
- Back Seat
- MSS SP-80, Type 2

For more detailed features, refer to page 35.

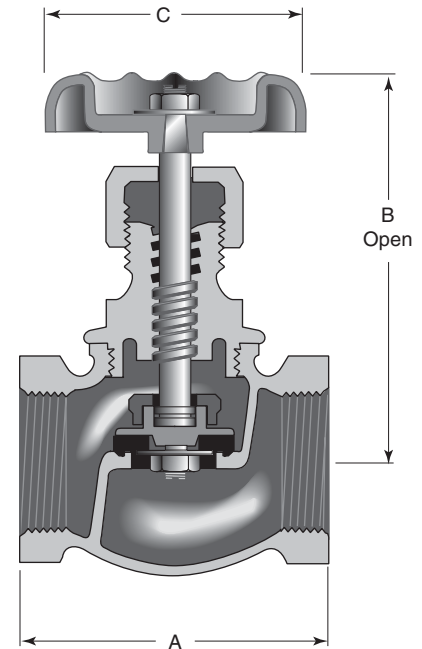

### Principal Parts & Materials

Part	Sizes	Material	ASTM
Body	All	Bronze	B62 alloy C83600
Bonnet	3/8" - 2"	Bronze	B62 alloy C83600
Disc Holder	3/8" - 3/4"	Brass	B16 H02
Disc Holder	1" - 2"	Bronze	B61 alloy 92200
Stem	All	Bronze	B371 alloy C69400
Disc	All	PTFE w/metal retainer	—

### Dimensions and Weights

Inches (millimeters) - pounds (kilograms)

	3/8 (10)	1/2 (15)	3/4 (20)	1 (25)	1 1/4 (32)	1 1/2 (40)	2 (50)
A	2.99 (76)	1.94 (49)	2.57 (65)	3.51 (89)	3.88 (99)	4.67 (119)	5.75 (146)
B	4.55 (116)	3.66 (93)	3.55 (90)	5.01 (127)	5.10 (130)	6.05 (154)	6.74 (171)
C	2.98 (76)	1.96 (50)	2.14 (54)	3.03 (77)	3.70 (94)	4.63 (118)	5.24 (133)
WTS.	1.90 (0.86)	0.70 (0.32)	1.10 (0.48)	2.80 (1.25)	4.10 (1.86)	6.20 (2.79)	9.80 (4.45)

## Class 150 • Union Bonnet • PTFE Disc • Threaded Ends

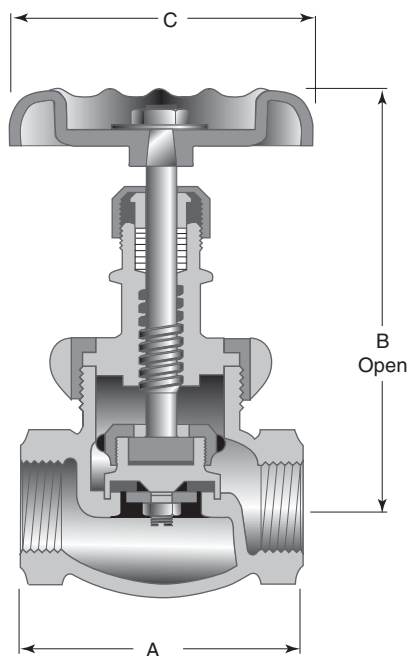

## Features

- PTFE Disc
- Threaded Ends
- Valves 2" and smaller have union bonnet. Disc holder retains disc and slips on the stem. Sizes 2 ½" and 3" have bolted bonnet; disc holder is fastened by a disc stem ring.
- Back Seat
- Integral Bronze Seat
- MSS SP-80, Type 2

For more detailed features, refer to page 35.

## Figure 7TF

## Size Range:

¼" through 3"

## Working Pressures Non-Shock:

150 psi Steam, Basic Rating

300 psi Cold Working Pressure

## Principal Parts &amp; Materials

Part	Sizes	Material	ASTM
Body	All	Bronze	B62 alloy C83600
Bonnet	¼" - ¾"	Brass	B16 H02
Bonnet	½" - 3"	Bronze	B62 alloy C83600
Disc Holder	¼" - ½"	Brass	B16 H02
Disc Holder	¾" - 3"	Bronze	B62 alloy C83600
Stem	All	Bronze	B371 alloy C69400
Disc	All	PTFE	—

## Dimensions and Weights

Inches (millimeters) - pounds (kilograms)

	¼ (6)	⅜ (10)	½ (15)	¾ (20)	1 (25)	1 ¼ (32)	1 ½ (40)	2 (50)	2 ½ (65)	3 (80)
A	1.96 (50)	1.96 (50)	2.58 (66)	2.96 (75)	3.52 (89)	4.03 (102)	4.57 (116)	5.72 (145)	7.27 (185)	8.60 (218)
B	4.25 (108)	4.19 (106)	4.11 (104)	5.16 (131)	5.55 (141)	6.52 (166)	7.34 (186)	7.51 (191)	8.68 (220)	9.75 (248)
C	2.13 (54)	2.13 (54)	2.25 (57)	2.96 (75)	3.03 (77)	3.69 (94)	4.61 (117)	5.24 (133)	6.97 (177)	7.00 (178)
WTS.	0.80 (0.36)	0.80 (0.36)	1.30 (0.59)	2.20 (1.00)	3.20 (1.45)	4.90 (2.22)	7.20 (3.24)	11.50 (5.22)	24.90 (11.29)	40.60 (18.42)



### 300 CWP • Threaded Bonnet • PTFE Disc • Solder Ends

Figure 1310

**Size Range:**

3/8" through 2"

**Working Pressures Non-Shock:**

300 psi Cold Working Pressure

**Features**

- Screwed Bonnet
- Solder Joint Ends
- Integral Bronze Seat
- Back Seat
- PTFE Disc
- MSS SP-80, Type 2

For more detailed features, refer to page 35.

**Caution:** Before installing solder joint valves, be sure solder or brazing alloy melting point is high enough to withstand line pressure/temperature conditions, and is compatible with fluid medium. See page 5 for adjusted pressure/temperature ratings.

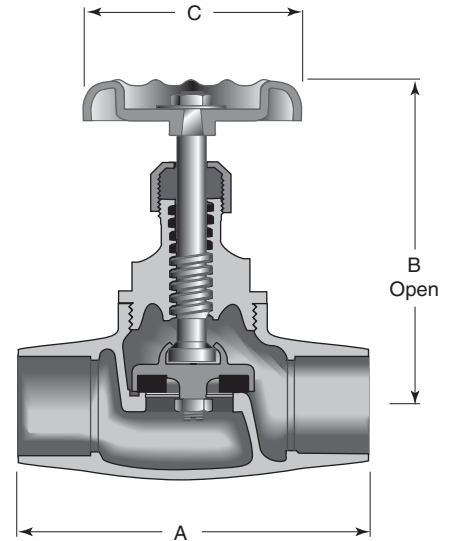

### Principal Parts & Materials

Part	Sizes	Material	ASTM
Body	All	Bronze	B62 alloy C83600
Bonnet	All	Bronze	B62 alloy C83600
Disc	All	PTFE w/metal retainer	—
Stem	All	Bronze	B371 alloy C69400

### Dimensions and Weights

Inches (millimeters) - pounds (kilograms)

	3/8 (10)	1/2 (15)	3/4 (20)	1 (25)	1 1/4 (32)	1 1/2 (40)	2 (50)
A	2.73 (69)	2.73 (69)	3.52 (89)	4.26 (108)	4.70 (119)	5.51 (140)	6.97 (177)
B	4.28 (109)	3.53 (90)	4.55 (116)	5.02 (128)	5.19 (132)	6.22 (158)	6.77 (172)
C	2.13 (54)	2.25 (54)	2.97 (75)	3.04 (77)	3.70 (94)	4.60 (117)	5.24 (133)
WTS.	1.00 (0.45)	1.00 (0.45)	1.70 (0.77)	2.40 (1.09)	3.70 (1.68)	5.20 (2.36)	8.50 (3.86)



**Class 150 • Union Bonnet • Stainless Steel Disc & Seat Ring • Threaded Ends**

### Features

- Union Bonnet, ¼"-2"
- Threaded Ends
- Bolted Bonnet, 2 ½" and 3"
- Back Seat
- Stainless Steel Seat Ring
- MSS SP-80, Type 3

For more detailed features, refer to page 35.

### Figure 14½ P

#### Size Range:

¼" through 3"

#### Working Pressures Non-Shock:

150 psi Steam, Basic Rating

300 psi Cold Working Pressure

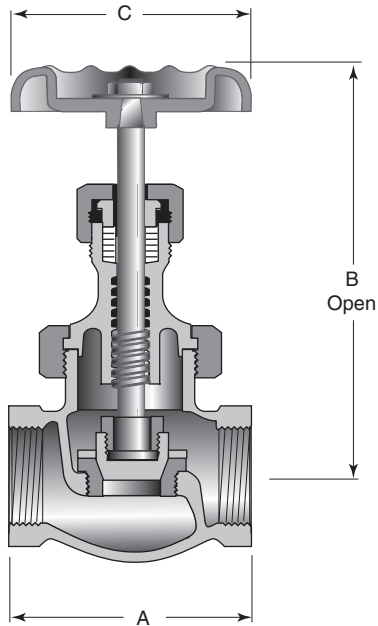

### Principal Parts & Materials

Part	Sizes	Material	ASTM
Body	All	Bronze	B62 alloy C83600
Bonnet	¼"-¾"	Brass	B16 H02
Bonnet	½"-3"	Bronze	B62 alloy C83600
Disc and seat ring	All	Stainless Steel	A276 S42000
Stem	All	Bronze	B371 alloy C69400

### Dimensions and Weights

Inches (millimeters) - pounds (kilograms)

	¼ (6)	⅜ (10)	½ (15)	¾ (20)	1 (25)	1 ¼ (32)	1 ½ (40)	2 (50)	2 ½ (65)	3 (80)
A	1.97 (50)	1.97 (50)	2.63 (67)	2.99 (76)	3.51 (89)	4.04 (103)	4.57 (116)	5.72 (145)	7.28 (185)	8.70 (221)
B	4.43 (113)	4.43 (113)	4.09 (104)	5.10 (130)	5.58 (142)	6.42 (163)	7.17 (182)	7.48 (190)	8.44 (214)	9.79 (249)
C	2.13 (54)	2.13 (54)	2.25 (57)	2.98 (76)	3.02 (77)	3.68 (93)	4.63 (118)	5.24 (133)	6.97 (177)	7.00 (178)
WTS.	0.90 (0.39)	0.90 (0.39)	1.30 (0.59)	2.20 (1.00)	3.20 (1.45)	4.80 (2.18)	7.10 (3.22)	11.50 (5.20)	25.10 (11.37)	40.50 (18.38)

### Class 200 • Union Bonnet • Plug Type Disc • Threaded Ends

#### Figure 212P

##### Size Range:

¼" through 3"

##### Working Pressures Non-Shock:

200 psi Steam, Basic Rating

400 psi Cold Working Pressure

#### Features

- Ideal for non-shock, severe service, such as throttling soot blower, blow-off boiler feed, and drip and drain lines
- Union Bonnet
- Tapered Plug Type Disc
- Stainless Steel Seat Ring
- Disc and Seat Ring are Renewable
- Back Seat
- MSS SP-80, Type 3

For more detailed features, refer to page 35.

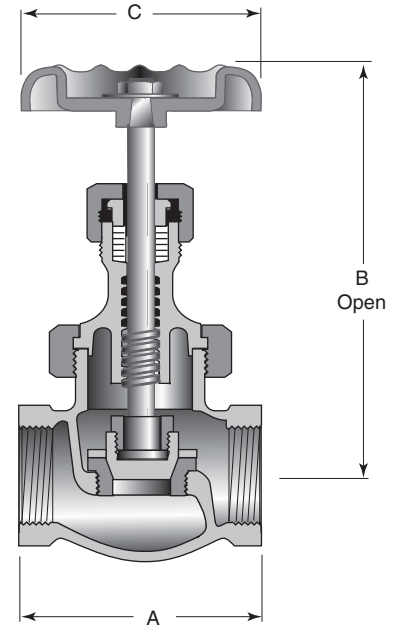

#### Principal Parts & Materials

Part	Material	ASTM
Body & bonnet	Bronze	B61 alloy C92200
Stem	Bronze	B371 alloy C69400
Disc & seat ring	Stainless Steel	A276 S42000

#### Dimensions and Weights

Inches (millimeters) - pounds (kilograms)

	¼ (6)	⅜ (10)	½ (15)	¾ (20)	1 (25)	1 ¼ (32)	1 ½ (40)	2 (50)	2 ½ (65)	3 (80)
A	1.97 (50)	1.97 (50)	2.63 (67)	2.99 (76)	3.51 (89)	4.04 (103)	4.57 (116)	5.72 (145)	7.28 (185)	8.70 (221)
B	4.43 (113)	4.43 (113)	4.09 (104)	5.10 (130)	5.58 (142)	6.42 (163)	7.17 (182)	7.48 (190)	8.44 (214)	9.79 (249)
C	2.13 (54)	2.13 (54)	2.50 (64)	2.98 (76)	3.02 (77)	3.68 (93)	4.63 (118)	5.24 (133)	6.97 (177)	7.00 (178)
WTS.	0.90 (0.39)	0.90 (0.39)	1.30 (0.59)	2.20 (1.00)	3.20 (1.45)	4.80 (2.18)	7.10 (3.22)	11.50 (5.20)	25.10 (11.37)	40.50 (18.38)

**Class 200 • Threaded Bonnet • Needle Type Disc • Threaded Ends**

**Features**

- Rising Stem
- Threaded Ends
- Screwed Bonnet
- Integral Seat
- Graphite Packing
- MSS Specification SP-80

For more detailed features, refer to page 35.

**Figure 88**

**Size Range:**

1/8" through 3/4"

**Working Pressures Non-Shock:**

200 psi Steam, Basic Rating

400 psi Cold Working Pressure

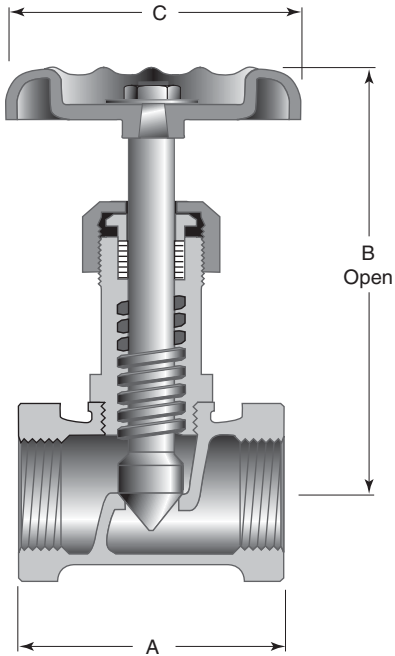

**Principal Parts & Materials**

Part	Size	Material	ASTM
Body	All	Bronze	B62 C83600
Bonnet	1/8"–3/8"	Bronze	B150 alloy C64200
Bonnet	1/2"–3/4"	Brass	B16 H02
Stem	All	Bronze	B150 alloy C64200

**Dimensions and Weights**

Inches (millimeters) - pounds (kilograms)

	1/8 (3)	1/4 (6)	3/8 (10)	1/2 (15)	3/4 (20)
A	1.16 (29)	1.53 (39)	1.78 (45)	2.03 (52)	2.28 (58)
B	2.94 (73)	2.88 (73)	3.06 (78)	3.56 (91)	4.12 (105)
C	1.75 (44)	1.75 (44)	1.75 (44)	2.06 (52)	2.56 (65)
WTS.	0.30 (0.14)	0.30 (0.14)	0.50 (0.22)	0.60 (0.27)	1.0 (0.45)

### Class 300 • Union Bonnet • Plug Type Disc • Renewable Stainless Steel Seats

#### Figure 382P

##### Size Range:

¼" through 3"

##### Working Pressures Non-Shock:

300 psi Steam, Basic Rating

¼" to 2" - (6mm-50mm)

1000 psi Cold Working Pressure

¼" to 2" - (6mm-50mm)

600 psi Cold Working Pressure

2 ½" to 3" - (65mm-80mm)

#### Features

- Ideal for non-shock, severe service, such as throttling soot blower, blow-off, boiler feed, and drip and drain lines
- Union Bonnet
- Threaded Ends
- Plug Type Disc
- Back Seat
- 450 Brinell hardened Stainless Steel Seat Ring
- Valves 2" (50mm) and smaller have compact union bonnet; 2 ½" (65mm) and 3" (80mm) use bolted bonnet.
- MSS Specification SP-80

For more detailed features, refer to page 35.

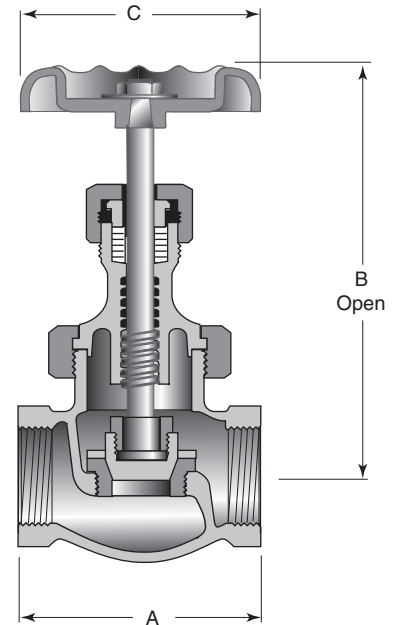

#### Principal Parts & Materials

Part	Sizes	Material	ASTM
Body	All	Bronze	B61 C92200
Bonnet	¼" - ⅜"	Brass	B16 H02
Bonnet	½" - 3"	Bronze	B61 C92200
Disc & seat ring	All	Stainless Steel	A276 S42000
Stem	All	Bronze	B371 C69400

#### Dimensions and Weights

Inches (millimeters) - pounds (kilograms)

	¼ (6)	⅜ (10)	½ (15)	¾ (20)	1 (25)	1 ¼ (32)	1 ½ (40)	2 (50)	2 ½ (65)	3 (80)
A	1.97 (50)	1.97 (50)	2.63 (67)	2.99 (76)	3.51 (89)	4.04 (103)	4.57 (116)	5.72 (145)	7.28 (185)	8.70 (221)
B	4.43 (102)	4.43 (102)	4.09 (97)	5.10 (119)	5.58 (131)	6.42 (146)	7.17 (162)	7.48 (172)	8.44 (192)	9.79 (220)
C	2.13 (54)	2.13 (54)	2.50 (64)	2.98 (76)	3.02 (77)	3.68 (93)	4.63 (118)	5.24 (133)	6.97 (177)	7.00 (178)
WTS.	0.90 (0.39)	0.90 (0.39)	1.30 (0.59)	2.20 (1.00)	3.20 (1.45)	4.80 (2.18)	7.10 (3.22)	11.50 (5.20)	25.10 (11.39)	40.50 (19.37)

**Class 150 • Union Bonnet • PTFE Disc • Threaded Ends**

**Features**

- Union Bonnet
- Threaded Ends
- Integral Bronze Seat
- Back Seat
- PTFE Disc
- MSS Specification SP-80

For more detailed features, refer to page 35.

**Figure 17TF**

**Size Range:**

¼" through 2"

**Working Pressures Non-Shock:**

150 psi Steam, Basic Rating  
300 psi Cold Working Pressure

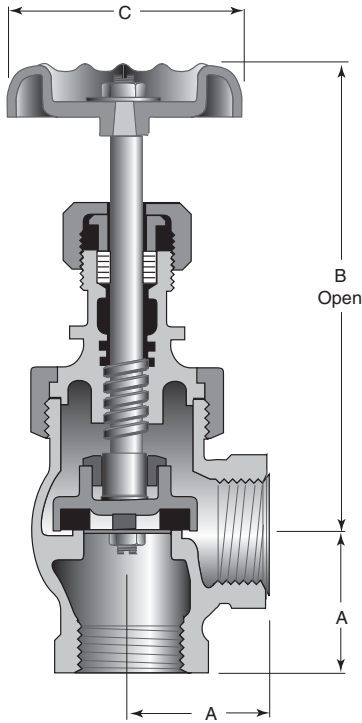

**Principal Parts & Materials**

Part	Sizes	Material	ASTM
Body	All	Bronze	B62 alloy C83600
Bonnet	¼" - ⅜"	Brass	B16 H02
Bonnet	½" - 2"	Bronze	B62 alloy C83600
Disc Holder	¼" - ½"	Brass	B16 H02
Disc Holder	¾" - 2"	Bronze	B62 alloy C83600
Stem	All	Bronze	B371 alloy C69400
Disc	All	PTFE w/metal holder	—

**Dimensions and Weights**

Inches (millimeters) - pounds (kilograms)

	¼	⅜	½	¾	1	1 ¼	1 ½	2
	(6)	(10)	(15)	(20)	(25)	(32)	(40)	(50)
A	1.18 (30)	1.18 (30)	1.17 (30)	1.39 (35)	1.63 (41)	2.02 (51)	2.18 (55)	2.68 (68)
B	4.12 (105)	3.97 (101)	3.91 (99)	5.18 (132)	5.34 (136)	6.53 (166)	6.96 (177)	7.34 (186)
C	2.13 (54)	2.13 (54)	2.25 (57)	2.95 (75)	3.03 (77)	3.69 (94)	4.63 (118)	5.24 (133)
WTS.	1.00 (0.43)	0.90 (0.41)	1.30 (0.59)	2.20 (1.00)	3.30 (1.47)	5.30 (2.38)	7.10 (3.22)	11.90 (5.38)

### Class 200 • Threaded Bonnet • Needle Type Disc • Threaded Ends

Figure 89  
Angle Valve  
Size Range:  
1/8" through 3/4"

**Working Pressures Non-Shock:**  
200 psi Steam, Basic Rating  
400 psi Cold Working Pressure

#### Features

- Rising Stem
- Screwed Bonnet
- Integral Seat
- Graphite Packing
- MSS Specification SP-80

For more detailed features,  
refer to page 35.

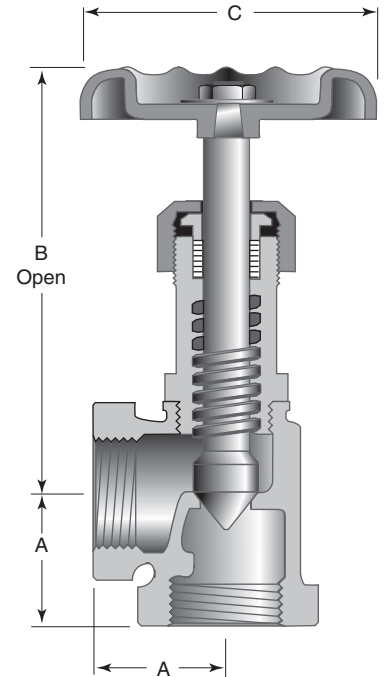

#### Principal Parts & Materials

Part	Size	Material	ASTM
Body	All	Bronze	B62 C83600
Bonnet	1/8"–3/8"	Bronze	B150 C64200
Bonnet	1/2"–3/4"	Brass	B16 H02
Stem	All	Bronze	B150 C64200

#### Dimensions and Weights

Inches (millimeters) - pounds (kilograms)

	1/8 (3)	1/4 (6)	3/8 (10)	1/2 (15)	3/4 (20)
A	0.58 (15)	0.78 (20)	0.91 (23)	1.06 (27)	1.23 (31)
B	2.85 (73)	2.88 (73)	3.06 (78)	3.56 (91)	4.20 (106)
C	1.75 (44)	1.75 (44)	1.75 (44)	2.06 (52)	2.50 (64)
WTS.	0.23 (0.11)	0.30 (0.14)	0.50 (0.22)	0.60 (0.27)	0.96 (0.44)

**Class 300 • Union Bonnet • Plug Type Disc • Renewable Stainless Steel Seats**

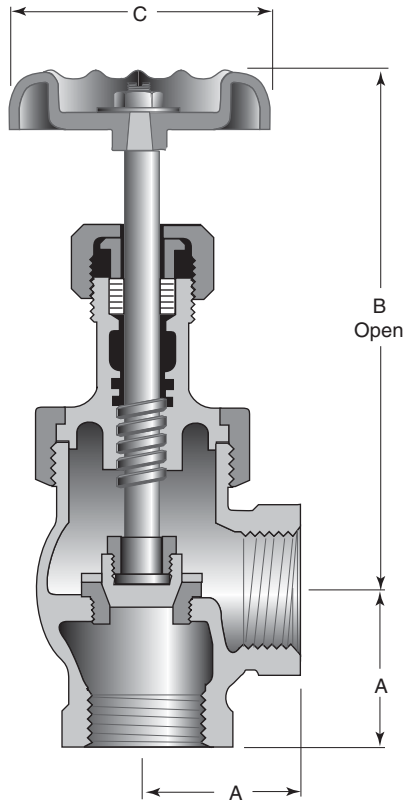

### Features

- Ideal for non-shock, severe service, such as throttling soot blower, blow-off, boiler feed, and drip and drain lines
- Plug Type Disc
- Union Bonnet
- Threaded Ends
- Wide Seating Surfaces
- 450 Brinell Hardened Stainless Steel Seat Ring
- Backseat
- MSS Specification SP-80

For more detailed features, refer to page 35.

### Figure 384P

#### Size Range:

¼" through 2"

#### Working Pressures Non-Shock:

300 psi Steam, Basic Rating

1000 psi Cold Working Pressure

### Principal Parts & Materials

Part	Sizes	Material	ASTM
Body	All	Bronze	B61 C92200
Bonnet	¼" - ⅜"	Brass	B16 H02
Bonnet	½" - 2"	Bronze	B61 C92200
Disc	All	Stainless Steel	A276 S42000
Stem	All	Bronze	B371 C69400
Seat Ring	All	Stainless Steel	A276 S42000

### Dimensions and Weights

Inches (millimeters) - pounds (kilograms)

	¼ (6)	⅜ (10)	½ (15)	¾ (20)	1 (25)	1 ¼ (32)	1 ½ (40)	2 (50)
A	1.14 (29)	1.17 (30)	1.13 (29)	1.37 (35)	1.63 (41)	2.03 (52)	2.19 (56)	2.74 (70)
B	4.24 (108)	4.21 (107)	4.01 (102)	4.97 (126)	5.35 (136)	6.31 (160)	6.99 (178)	7.17 (182)
C	2.13 (54)	2.13 (54)	2.50 (64)	2.96 (75)	3.00 (76)	3.76 (96)	4.60 (117)	5.26 (134)
WTS.	1.00 (0.45)	0.90 (0.41)	1.30 (0.59)	2.20 (1.00)	3.30 (1.50)	5.70 (2.59)	7.70 (3.49)	13.10 (5.94)



## Detailed Features

Check valves permit flow in one direction only and close automatically when flow reverses. They are entirely automatic in action, depending upon pressure and velocity of flow within the line to perform their functions of opening and closing.

The discs and any associated moving parts may be in a constant state of movement if the velocity pressure is not sufficient to hold the disc in a wide open and stable position. Premature wear and noisy operation or vibration can be avoided by selecting the size of the check valve on the basis of flow conditions rather selecting the check valve according to the size of the pipeline.

Each valve in this section is classified by its pressure rating. All valves designated as Class 125, 150, 200 or 300 comply with MSS SP-80 Standard Practice.

Horizontal Lift Check Valves have an internal construction similar to globe valves. The flow follows a turning course through a horizontal bridge wall on which the disc is seated. The disc is equipped with guides either above or below the seat which move vertically in integral guides in the cap and bridge wall. The disc is seated by backflow or by gravity when there is no flow. It operates in horizontal lines only, the disc being free to rise and fall depending on the pressure under it.

Vertical Lift Check Valves are designed to operate on upward flow only. They must always be installed vertically with pressure below the seat. The disc is seated by backflow or by gravity when there is no flow.

Swing Check Valves with straight-through body design and wide hinge support provide turbulence-free flow and accurate seating. There is no tendency for the seating surfaces to gall or score because the disc meets the flat seat squarely without rubbing. Also, some types of swing check valves are furnished with soft faced discs backed

up by sold metal which provides even more positive seating.

Below are two formulas that can be used to determine the minimum velocity necessary to hold a check valves in a wide open and stable position.  $v$  is equal to velocity in feet per second and  $V$  is the specified volume of fluid in cubic feet per pound.

$$\text{Swing Check Formula } v = \beta^2 35 \sqrt{V}$$

$$\text{Lift Check Formula } v = \beta^2 40 \sqrt{V}$$

$$\text{where } \beta^2 = \left( \frac{\text{Port Diameter}}{\text{Nominal Pipe Diameter}} \right)^2$$

Sizing check valves on this basis may often result in the use of valves that are smaller than the pipe in which they are used, necessitating the use of reducers for installation. The pressure drop will be no greater than that of a larger valve that is partially open. Valve life will be greatly extended, and the added bonus, of course, is the lower cost of the smaller valves.

### Superior Features

Positive Seating - The 45° seat angle in relation to direction of flow and the two piece swivel disc combine to provide full seating whether installed horizontally or vertically, regardless of pipeline pitch. Seat leakage from hinge distortion is virtually eliminated. For installations requiring it, the composition disc versions give the extra positive shut-off inherent in a soft seating disc.

Longer Life - The sturdy, sensible body design will give years of satisfactory service under rugged operating conditions. The swivel hinge-disc connection permits the disc to rotate in service, virtually eliminating concentrated or "spot" seat wear. Easy seat regrinding or composition disc

replacement adds years to the service life of these valves.

Easy Maintenance - Easy access via the large cap and the Y pattern body permits quick regrinding of the seating surfaces on the metal seated valves by means of the rotating disc. Similarly, it is quick and easy to replace discs on the composition disc valves. By removing the hinge pin plug, hinge pin and cap, the hinge-disc assembly can be removed to permit replacing the disc.

Parts Interchangeability - Among class 125, 150, 200 and 300 swing check valves, the disc and hinge assembly is fully interchangeable; Crane metal or composition disc seating valves have this great advantage of using the same disc/hinge assembly within their respective seating categories.

Body is made of bronze conforming to requirements of ASTM B62 or B61 depending on valve pressure class. Like all parts, bodies are designed to withstand high internal pressures and line strains... and are proportioned to assure a high safety factor under recommended working pressures.

Disc and hinge are made from high grade materials especially selected to perform dependably in the services for which the valve is recommended.

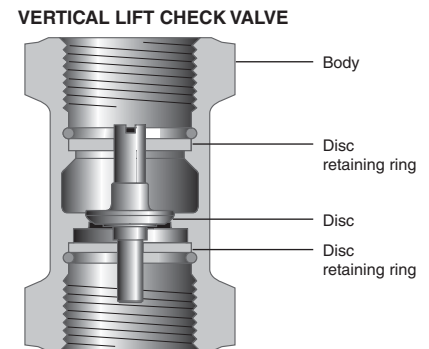
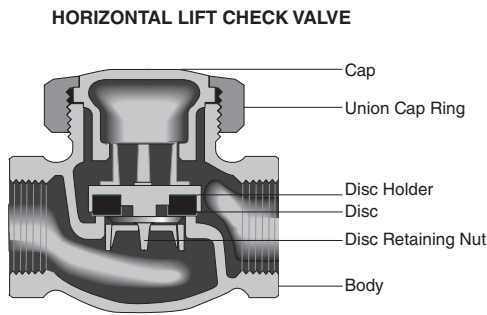
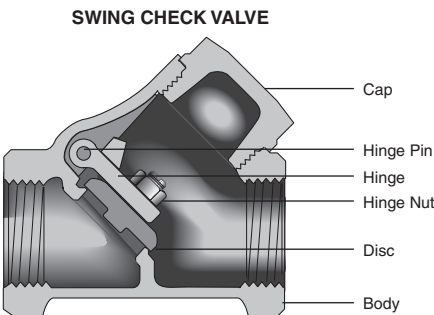
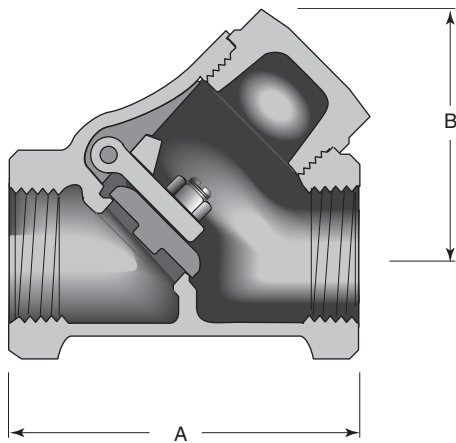

Figure 37

# Bronze Swing Check Valve



**Class 125 • Threaded Cap • Brass/Bronze Disc • Threaded Ends**



### Features

- Y-Pattern Body with Integral Seat
- Seat can be reground while the valve remains in the line
- Threaded Ends
- Always install with pressure under the disc in vertical or horizontal position. An arrow cast on the body indicates the correct direction of flow.
- Screwed Cap
- MSS Specification SP-80

For more detailed features, refer to page 47.

### Figure 37

#### Size Range:

¼" through 3"

#### Working Pressures Non-Shock:

125 psi Steam, Basic Rating

200 psi Cold Working Pressure

### Principal Parts & Materials

Part	Sizes	Material	ASTM
Body	All	Bronze	B62 alloy C83600
Cap	All	Bronze	B61 alloy C92200
Disc	¼"-¾"	Brass	B16 H02
Disc	1" - 3"	Bronze	B61 alloy C92200
Hinge	All	Bronze	B584 alloy C87600
Hinge pin	All	Stainless Steel	18-8

### Dimensions and Weights

Inches (millimeters) - pounds (kilograms)

	¼ (6)	⅜ (10)	½ (15)	¾ (20)	1 (25)	1 ¼ (32)	1 ½ (40)	2 (50)	2 ½ (65)	3 (80)
A	2.18 (55)	2.18 (55)	2.19 (56)	2.75 (70)	3.24 (82)	3.84 (98)	4.40 (112)	5.18 (132)	6.13 (156)	7.40 (188)
B	1.50 (38)	1.50 (38)	1.63 (41)	1.91 (49)	2.50 (64)	2.90 (74)	3.42 (87)	4.19 (106)	5.09 (129)	5.95 (151)
WTS.	0.60 (0.27)	0.60 (0.27)	0.70 (0.32)	1.10 (0.50)	1.80 (0.82)	2.60 (1.18)	3.90 (1.77)	6.10 (2.77)	10.30 (4.67)	15.10 (6.85)

### Class 125 • Threaded Cap • PTFE Disc • Threaded Ends

#### Figure 41TF

##### Size Range:

½" through 2"

##### Working Pressures Non-Shock:

125 psi Steam, Basic Rating

200 psi Cold Working Pressure

#### Features

- Recommended for non-shock water, oil or gas.
- Threaded Ends
- Screwed Cap
- Y-Pattern Body
- PTFE Disc
- Always install with pressure under the disc in vertical or horizontal position. An arrow cast on the body indicates the correct direction of flow.
- MSS Specification SP-80

For more detailed features, refer to page 47.

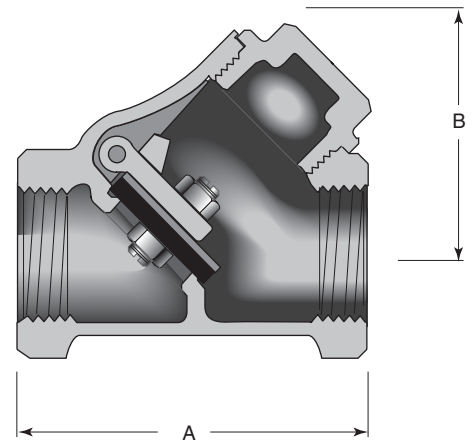

#### Principal Parts & Materials

Part	Sizes	Material	ASTM
Body	All	Bronze	B62 alloy C83600
Cap	All	Bronze	B61 alloy C92200
Disc	All	PTFE w/metal holder	—
Hinge	All	Bronze	B584 alloy 87600
Hinge pin	All	Stainless Steel	18-8

#### Dimensions and Weights

Inches (millimeters) - pounds (kilograms)

	½	¾	1	1 ¼	1 ½	2
	(15)	(20)	(25)	(32)	(40)	(50)
A	2.19 (56)	2.75 (70)	3.23 (82)	3.84 (98)	4.40 (112)	5.18 (132)
B	1.64 (42)	1.92 (49)	2.45 (62)	2.86 (73)	3.42 (87)	4.13 (105)
WTS.	0.70 (0.32)	1.10 (0.50)	1.80 (0.82)	2.60 (1.18)	3.90 (1.77)	6.20 (2.81)

Figure 137

# Bronze Swing Check Valve



**Class 150 • Threaded Cap • Brass/Bronze Disc • Threaded Ends**

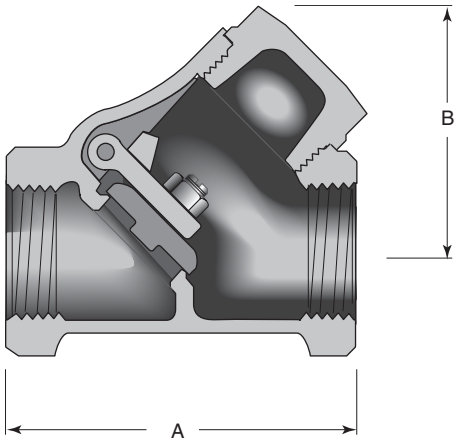

### Features

- Y-Pattern Body
- Threaded Ends
- Free to rotate disc design allows the disc to close in a different position on the integral seat each time it operates.
- Re grindable Seat
- Always install with pressure under the disc in vertical or horizontal position. An arrow cast on the body indicates the correct direction of flow.
- Screwed Cap
- MSS Specification SP-80

For more detailed features, refer to page 47.

### Figure 137

#### Size Range:

¼" through 3"

#### Working Pressures Non-Shock:

150 psi Steam, Basic Rating  
300 psi Cold Working Pressure

### Principal Parts & Materials

Part	Sizes	Material	ASTM
Body	All	Bronze	B62 alloy C83600
Cap	All	Bronze	B61 alloy C92200
Hinge	All	Bronze	B584 alloy C87600
Disc	¼" - ¾"	Brass	B16 H02
Disc	1" - 3"	Bronze	B61 alloy C92200
Hinge Pin	All	Stainless Steel	18-8

### Dimensions and Weights

Inches (millimeters) - pounds (kilograms)

	¼ (6)	⅜ (10)	½ (15)	¾ (20)	1 (25)	1 ¼ (32)	1 ½ (40)	2 (50)	2 ½ (65)	3 (80)
A	2.18 (55)	2.18 (55)	2.19 (56)	2.75 (70)	3.24 (82)	3.84 (98)	4.40 (112)	5.18 (132)	6.13 (156)	7.40 (188)
B	1.50 (38)	1.50 (38)	1.63 (41)	1.91 (49)	2.50 (64)	2.90 (74)	3.42 (87)	4.19 (106)	5.09 (129)	5.95 (151)
WTS.	0.60 (0.27)	0.60 (0.27)	0.70 (0.32)	1.10 (0.50)	1.80 (0.82)	2.60 (1.18)	3.90 (1.77)	6.10 (2.77)	10.30 (4.67)	15.10 (6.85)

**300 CWP • Threaded Cap • Brass/Bronze Disc • Solder Ends**

Figure 1342

**Size Range:**

½" through 3"

**Working Pressures Non-Shock:**

300 psi Cold Working Pressure

**Features**

- Y-Pattern Body
- Solder Joint Ends
- Always install with pressure under the disc in vertical or horizontal position. An arrow cast on the body indicates the correct direction of flow.
- Screwed Cap
- MSS Specification SP-80

For more detailed features, refer to page 47.

**Caution:** Before installing solder-joint valves, be sure the solder or brazing alloy is compatible with the fluid media and the alloy melting point is high enough to withstand the pressure and temperature conditions. See page 5 for adjusted pressure/temperature ratings.

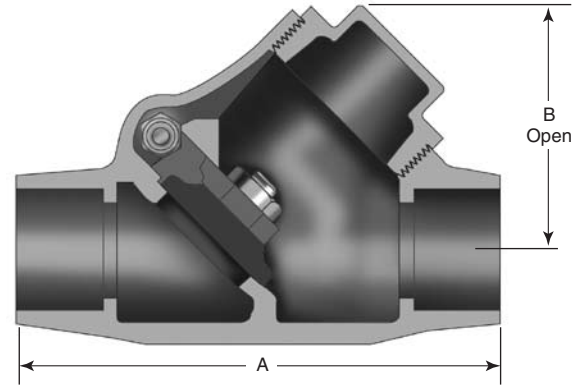

### Principal Parts & Materials

Part	Sizes	Material	ASTM
Body	All	Bronze	B62 alloy C83600
Cap	All	Bronze	B61 alloy C92200
Disc	½" - ¾"	Brass	B16 H02
Disc	1" - 3"	Bronze	B61 alloy C92200
Hinge	All	Bronze	B584 alloy C87600
Hinge Pin	All	Stainless Steel	18-8

### Dimensions and Weights

Inches (millimeters) - pounds (kilograms)

	½ (15)	¾ (20)	1 (25)	1 ¼ (32)	1 ½ (40)	2 (50)	2 ½ (65)	3 (80)
A	2.70 (69)	3.61 (92)	4.25 (108)	4.82 (122)	5.60 (142)	6.86 (174)	7.78 (198)	9.31 (236)
B	1.61 (41)	1.92 (49)	2.50 (64)	2.84 (72)	3.47 (88)	4.17 (106)	5.00 (127)	5.90 (150)
WTS.	0.70 (0.32)	1.10 (0.50)	1.80 (0.82)	2.50 (1.13)	4.10 (1.86)	6.40 (2.90)	10.60 (4.81)	15.90 (7.21)

**Class 150 • Threaded Cap • PTFE Disc • Threaded Ends**

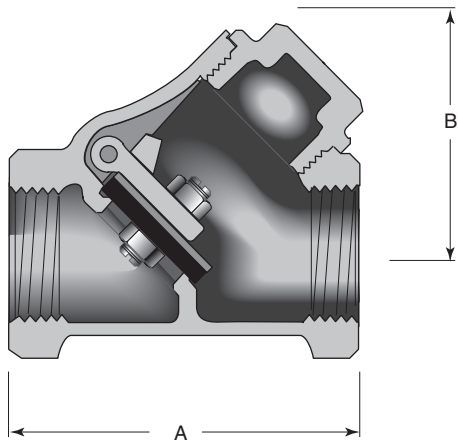

**Features**

- Y-Pattern Body
- Threaded Ends
- PTFE Disc
- Screwed Cap
- MSS Specification SP-80

For more detailed features, refer to page 47.

**Figure 141TF**

**Size Range:**

½" through 2"

**Working Pressures Non-Shock:**

150 psi Steam, Basic Rating

300 psi Cold Working Pressure

**Principal Parts & Materials**

Part	Material	ASTM
Body	Bronze	B62 alloy C83600
Cap	Bronze	B61 alloy C92200
Hinge	Bronze	B584 alloy C87600
Disc	PTFE w/metal holder	—
Hinge Pin	Stainless Steel	18-8

**Dimensions and Weights**

Inches (millimeters) - pounds (kilograms)

	½ (15)	¾ (20)	1 (25)	1 ¼ (32)	1 ½ (40)	2 (50)
A	2.19 (56)	2.75 (70)	3.23 (82)	3.84 (98)	4.40 (112)	5.18 (132)
B	1.64 (42)	1.92 (49)	2.45 (62)	2.86 (73)	3.42 (87)	4.13 (105)
WTS.	0.70 (0.32)	1.10 (0.50)	1.80 (0.82)	2.60 (1.18)	3.90 (1.77)	6.20 (2.81)

**Class 200 • Threaded Cap • Brass/Bronze Disc • Threaded Ends**

Figure 36

**Size Range:**

¼" through 3"

**Working Pressures Non-Shock:**

200 psi Steam, Basic Rating

400 psi Cold Working Pressure

**Features**

- Y-Pattern Body
- Threaded Ends
- Screwed Cap
- Rotating disc virtually eliminates "spot" seat wear.
- Always install with pressure under the disc in vertical or horizontal position. An arrow cast on the body indicates the correct direction of flow.
- MSS Specification SP-80

For more detailed features, refer to page 47.

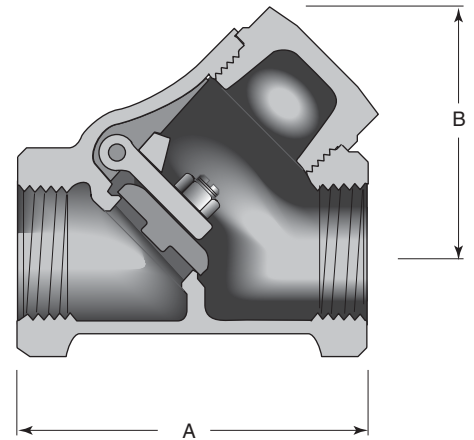

**Principal Parts & Materials**

Part	Sizes	Material	ASTM
Body & cap	All	Bronze	B61 alloy C92200
Hinge	All	Bronze	B584 alloy C87600
Disc	¼" - ¾"	Brass	B16 H02
Disc	1" - 3"	Bronze	B61 alloy C92200
Hinge Pin	All	Stainless Steel	18-8

**Dimensions and Weights**

Inches (millimeters) - pounds (kilograms)

	¼ (6)	⅜ (10)	½ (15)	¾ (20)	1 (25)	1 ¼ (32)	1 ½ (40)	2 (50)	2 ½ (65)	3 (80)
A	2.18 (55)	2.18 (55)	2.19 (56)	2.75 (70)	3.21 (82)	3.87 (98)	4.40 (112)	5.18 (132)	6.94 (176)	8.25 (210)
B	1.52 (39)	1.52 (39)	1.67 (42)	1.95 (50)	2.55 (65)	3.01 (76)	3.40 (86)	4.30 (109)	4.69 (119)	5.97 (152)
WTS.	0.60 (0.27)	0.60 (0.27)	0.80 (0.36)	1.20 (0.54)	1.90 (0.86)	2.70 (1.22)	4.30 (1.95)	7.10 (3.22)	13.90 (6.30)	21.60 (9.80)

**200 CWP • Threaded Cap • Brass/Bronze Disc • Solder Ends**

**Features**

- Y-Pattern Body
- Solder Joint Ends
- Screwed Cap
- MSS Specification SP-80, Type 3

For more detailed features, refer to page 47.

**Figure 1340**

**Size Range:**

½" through 3"

**Working Pressures Non-Shock:**

200 psi Cold Working Pressure

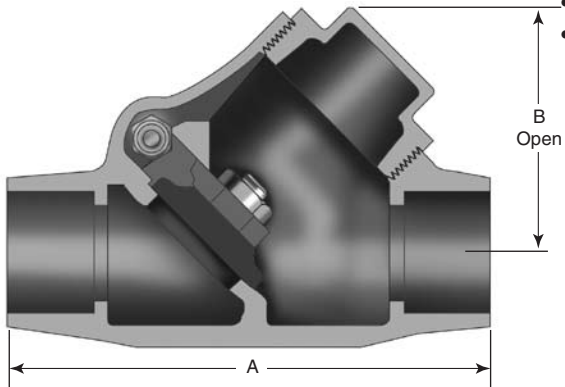

**Principal Parts & Materials**

Part	Size	Material	ASTM
Body	All	Bronze	B62 alloy C83600
Cap	All	Bronze	B61 alloy C92200
Disc	½"–¾"	Brass	B16 alloy H02
Disc	1"–3"	Bronze	B62 alloy C83600
Hinge	All	Bronze	B584 alloy C87600
Hinge Pin	All	Stainless Steel	A276 type 304

**Dimensions and Weights**

Inches (millimeters) - pounds (kilograms)

	½ (15)	¾ (20)	1 (25)	1 ¼ (32)	1 ½ (40)	2 (50)	2 ½ (65)	3 (80)
A	2.69 (68)	3.63 (92)	4.25 (108)	4.81 (122)	5.56 (141)	6.87 (174)	7.78 (198)	9.19 (233)
B	1.63 (41)	2.00 (51)	2.50 (62)	3.00 (76)	3.50 (89)	4.00 (102)	4.75 (121)	5.63 (143)
WTS.	0.60 (0.27)	1.00 (0.45)	1.50 (0.68)	2.20 (1.00)	3.30 (1.50)	5.40 (2.45)	9.20 (4.17)	14.30 (6.49)



### Class 300 • Threaded Cap • Brass/Bronze Disc • Threaded Ends

#### Figure 76E

##### Size Range:

¼" through 3"

##### Working Pressures Non-Shock:

300 psi Steam, Basic Rating

1000 psi Cold Working Pressure

¼" to 2" - (6mm - 50mm)

600 psi Cold Working Pressure

2 ½" to 3" - (65mm - 80mm)

#### Features

- Y-Pattern Body
- Threaded Ends
- Re grindable Seat
- Screwed Cap
- Always install with pressure under the disc in vertical or horizontal position. An arrow cast on the body indicates the correct direction of flow.
- MSS Specification SP-80

For more detailed features, refer to page 47.

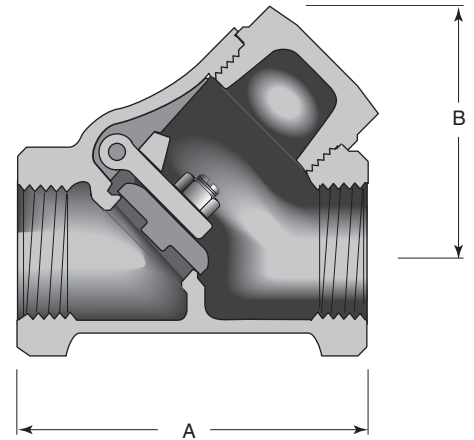

#### Principal Parts & Materials

Part	Sizes	Material	ASTM
Body & cap	All	Bronze	B61 alloy C92200
Hinge	All	Bronze	B584 alloy C87600
Disc	¼" - ¾"	Brass	B16 H02
Disc	1" - 3"	Bronze	B61 alloy C92200
Hinge Pin	All	Stainless Steel	18-8

#### Dimensions and Weights

Inches (millimeters) - pounds (kilograms)

	¼ (6)	⅜ (10)	½ (15)	¾ (20)	1 (25)	1 ¼ (32)	1 ½ (40)	2 (50)	2 ½ (65)	3 (80)
A	2.18 (55)	2.18 (55)	2.19 (56)	2.72 (69)	3.23 (82)	3.83 (97)	4.40 (112)	5.16 (131)	6.94 (176)	8.25 (210)
B	1.52 (39)	1.52 (39)	1.67 (42)	1.95 (50)	2.55 (65)	3.01 (76)	3.40 (86)	4.30 (109)	4.69 (119)	5.97 (152)
WTS.	0.60 (0.27)	0.60 (0.27)	0.80 (0.36)	1.20 (0.54)	1.90 (0.86)	2.70 (1.22)	4.30 (1.95)	7.10 (3.22)	13.90 (6.30)	21.60 (9.80)

# Figure 29 Bronze Vertical Lift Check Valve



## Class 125 • Brass/Bronze Disc • Threaded Ends

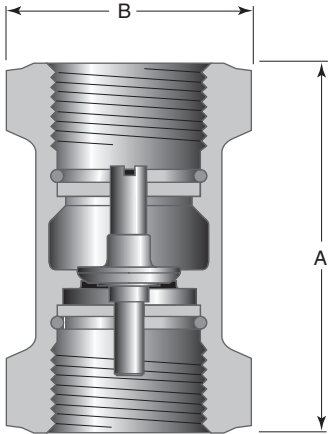

### Features

- These lift check valves have a one piece body with a bronze disc. The design is conceived for operation on upward flow only. Always install vertically with pressure below the seat and inlet end down.
- Seats are integral with body. Disc is precisely guided at top and bottom, assuring accurate seating.
- Excellent choke for suction lines and general service
- MSS Specification SP-80

For more detailed features, refer to page 47.

### Figure 29

#### Size Range:

¼" through 3"

#### Working Pressures Non-Shock:

125 psi Steam, Basic Rating

200 psi Cold Working Pressure

### Principal Parts & Materials

Part	Sizes	Material	ASTM
Body	All	Bronze	B62 C83600
Disc	¼" - ½"	Brass	B36 C-2600 H04
Disc	¾"	Bronze	B505 C83600
Disc	1" - 2"	Bronze	B62 C83600
Disc guide	All	Brass	B36 C26000 H04
Retaining ring	All	Brass	B134 C26000

### Dimensions and Weights

Inches (millimeters) - pounds (kilograms)

	¼ (6)	⅜ (10)	½ (15)	¾ (20)	1 (25)	1 ¼ (32)	1 ½ (40)	2 (50)	2 ½ (65)	3 (80)
A	1.96 (50)	1.96 (50)	2.15 (55)	2.32 (59)	2.90 (74)	3.28 (83)	3.60 (91)	4.00 (102)	5.00 (127)	5.42 (138)
B	1.08 (27)	1.08 (27)	1.26 (32)	1.54 (39)	1.87 (47)	2.36 (60)	2.58 (66)	3.24 (82)	3.94 (100)	4.74 (120)
WTS.	0.30 (0.14)	0.30 (0.11)	0.40 (0.16)	0.50 (0.23)	0.90 (0.41)	1.50 (0.68)	2.10 (0.93)	3.10 (1.38)	6.30 (2.86)	8.60 (3.88)

**Class 150 • Union Cap • PTFE Disc • Threaded Ends**

**Figure 27TF**

**Size Range:**

¼" through 2"

**Working Pressures Non-Shock:**

150 psi Steam, Basic Rating

300 psi Cold Working Pressure

**Features**

- Lift Check Design
- Threaded Ends
- Union Cap
- Disc holder is guided top and bottom on sizes ½" and larger
- PTFE disc
- MSS Specification SP-80

**Note:**

For horizontal installation only.

For more detailed features, refer to page 47.

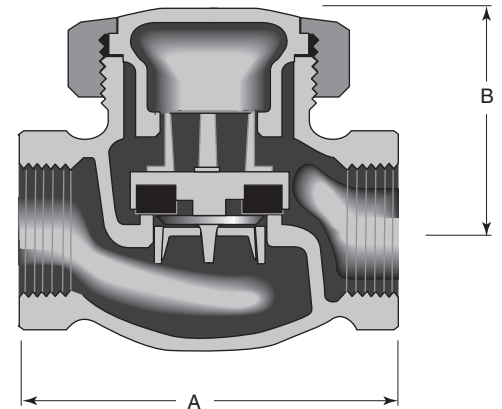

**Principal Parts & Materials**

Part	Sizes	Material	ASTM
Body, cap & union ring	All	Bronze	B62 alloy C83600
Disc	All	PTFE w/metal holder	—

**Dimensions and Weights**

Inches (millimeters) - pounds (kilograms)

	¼ (6)	⅜ (10)	½ (15)	¾ (20)	1 (25)	1 ¼ (32)	1 ½ (40)	2 (50)
A	1.96 (50)	1.96 (50)	2.62 (67)	2.95 (75)	3.50 (89)	4.11 (104)	4.59 (117)	5.74 (146)
B	1.32 (34)	1.28 (33)	1.56 (40)	1.89 (48)	2.29 (58)	2.66 (68)	2.87 (73)	3.32 (84)
WTS.	0.50 (0.23)	0.50 (0.23)	1.00 (0.43)	1.50 (0.68)	2.30 (1.04)	3.60 (1.63)	5.30 (2.38)	8.90 (4.04)

**Class 300 • Union Cap • Bronze Disc • Threaded Ends**

### Features

- Lift Check Design
- Threaded Ends
- Union Cap
- For more detailed features, refer to page 47.

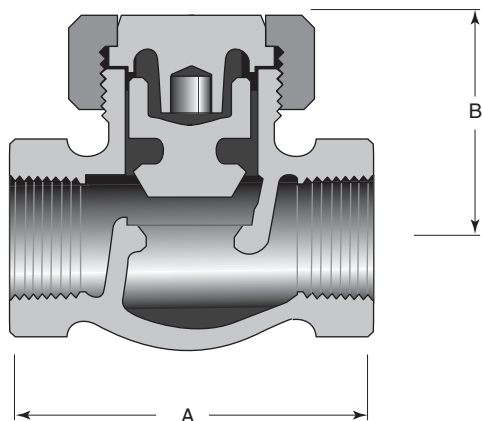

### Figure 366E

#### Size Range:

½" through 2"

#### Working Pressures Non-Shock:

300 psi Steam, Basic Rating at 450° F  
1000 psi Cold Working Pressure

### Principal Parts & Materials

Part	Sizes	Material	ASTM
Body	All	Bronze	B62 alloy C83600
Disc	All	Bronze	B62 alloy C83600
Cap	½"	Bronze	B138 alloy C67500
Cap	¾" - 2	Bronze	B62 alloy C83600
Union ring	All	Bronze	B62 alloy C83600

### Dimensions and Weights

Inches (millimeters) - pounds (kilograms)

	½ (15)	¾ (20)	1 (25)	1 ¼ (32)	1 ½ (40)	2 (50)
A	2.50 (64)	2.94 (75)	3.50 (89)	4.06 (103)	4.62 (117)	5.75 (146)
B	1.46 (37)	1.88 (48)	2.00 (51)	2.38 (60)	2.62 (66)	3.25 (83)
WTS.	1.0 (.45)	1.7 (.77)	2.6 (1.20)	4.1 (1.88)	5.6 (2.56)	10.0 (4.55)

**Notes:**

Notes:



# CRANE®

## Global Headquarters

19241 David Memorial Drive, Suite 150  
Shenandoah, Texas 77385  
Tel: +1-936-271-6500  
Fax: +1-936-271-6510

## Cullman, AL Operations

2129 3rd Avenue S.E.  
Cullman, Alabama 35055  
Tel: 256-775-3800  
Fax: 256-775-3860

## Customer Service

2129 3rd Avenue S.E.  
Cullman, Alabama 35055  
Tel: 256-775-3800  
Fax: 256-775-3860

[www.craneenergy.com](http://www.craneenergy.com)

# Crane Energy Flow Solutions

## CENTER LINE®

Resilient Seated Butterfly and Check Valves  
Pneumatic and Electric Actuators

## CRANE®

Cast Steel, Bronze, and Iron Valves

## FLOWSEAL®

High Performance Butterfly Valves

## JENKINS®

Bronze, Iron, and Cast Steel Valves

## DUO-CHEK®

High Performance Wafer Check Valves

## ALOYCO®

Corrosion Resistant Gate, Globe and Check Valves

## UNI-CHEK®

Severe Service Check Valves

## NOZ-CHEK® & COMPAC-NOZ®

Severe Service, Nozzle-Type Check Valves

## PACIFIC®

High Pressure and Severe Service Valves  
Quarter Turn Severe Service Plug Valves

## WEDGEPLUG®

Severe Service, Metal-Seated Plug Valves

# CRANE®

## Energy Flow Solutions

Crane, Center Line, Flowseal, Duo-Chek, Uni-Chek, Pacific,  
Jenkins, Alloyco, Noz-Chek, Compac-Noz and Wedgeplug are  
all trademarks of Crane Co. ©2008