

The Flowseal metal-to-metal seat high performance butterfly valve incorporates an Inconel seat for higher tensile strength, a 300 series stainless steel back-up ring in the seat cavity for axial seat support, and a disc that is case hardened by nitriding.

The Inconel seat, by its dynamic and flexible design, applies enough force per linear inch against the disc edge

(Rockwell Hardness of C66 to C70) to obtain an optimum sealing characteristic while controlling the loads between the metal surfaces.

The Flowseal metal-to-metal seat valve is utilized for temperatures up to 900°F, in compliance with ASME B16.34 pressure/temperature specifications. Leakage is rated at Class IV per ASME FCI 70-2.

PRINCIPLE OF METAL SEATING

Metal-to-metal sealing is accomplished by the “line contact” between a spherical surface and conical surface. Figure 1 illustrates a typical globe control valve seat and plug. The plug seating surface is the segment of a sphere; when engaged against the seat ring, a line contact seal is achieved.

In a metal seat design, it is necessary to apply enough force per linear inch to maintain a tight metal-to-metal contact between the sealing members; however, high linear thrust can cause a collapse of the seating members (“bearing failure”).

Figure 1

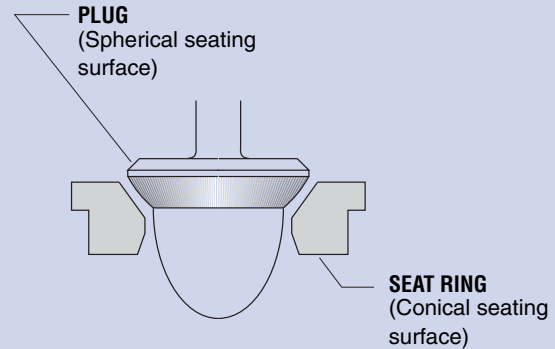

DISC CLOSED, Self-Energized Seal

In Figure 2, the Flowseal disc and seat are engaged, and the process fluid is under low pressure. The spherical edge of the disc, with a larger diameter than the conical seat tongue, imparts a thrust of approximately 600 pounds per linear inch against the seat. The mechanical properties and shape of the Inconel seat allow it to both flex and maintain a constant thrust against the disc.

This controlled loading prevents the occurrence of bearing failure and reduces the leakage and wear between the components.

Figure 2

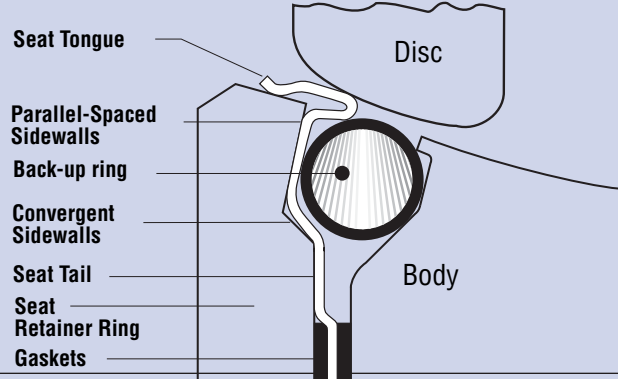

DISC CLOSED, Pressure-Energized Seal (Seat Upstream)

As line pressure increases, the process fluid enters the sidewall area and applies a load against the parallel-spaced sidewall and convergent sidewall of the metal seat. The seat moves towards the downstream sidewall while being supported axially by the support ring, as shown in Figure 3. The cavity shape confines the seat movement and directs the movement radially inward towards the disc; the higher the line pressure, the tighter the line contact between the disc and seat. The Inconel seat, shaped by a special hydroforming process, is able to flex under these loads and return to its original shape after removal of the loads.

This dynamic seal, patented by Flowseal, is totally unique among high performance butterfly valves.

Figure 3

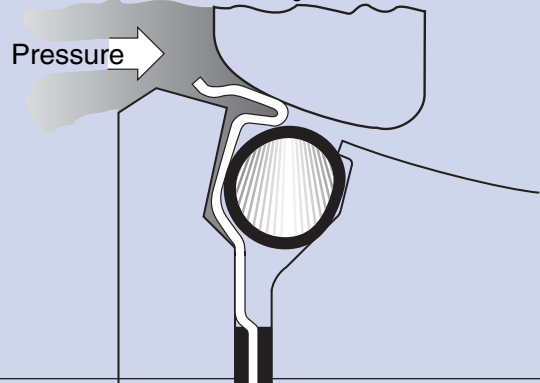

DISC CLOSED, Pressure-Energized Seal (Seat Downstream)

The Flowseal valve is bi-directional (in some instances, modifications may be required to operate this arrangement for dead end service). The cavity and seat sidewalls are symmetrically designed to permit, confine and direct movement of the seat to the disc to dynamically seal with line pressure in the seat downstream direction, as in Figure 4. Recommended installation direction is “SUS” (seat upstream), as in Figure 3.

The stainless steel back-up ring interacts dynamically with the metal seat for axial support in seat sealing. Additionally, this ring effectively restricts corrosion and particulate build-up in the cavity.

Figure 4

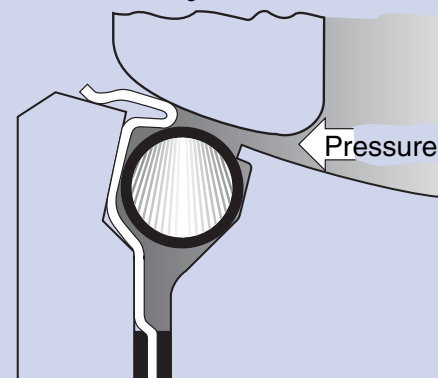

KEY

Square key valve-to-operator connection provides an externally controlled failure point upon over-torquing.

GLAND FLANGE

Applies load against packing gland to prevent external leakage. Fully adjustable.

PACKING

Common materials are TFE for up to 450 °F and Graphite for up to 900 °F.

WEDGE RING

Stainless steel band wedged between valve body and retainer ring by set screws to lock seat and retainer ring in position on valve sizes 2" through 30". Socket head cap screws are used on valve sizes 36" and larger.

WEDGE PINS

Provide positive mechanical attachment of disc to shaft.

OVERTRAVEL STOP

Prevents disc from rotating into wrong quadrant.

SET SCREWS

Cone point screws force wedge ring outward to lock seat retainer in position on valve sizes 2" through 30". Socket head cap screws are used on valve sizes 36" and larger.

METAL SEAT

Patented metal seat with metal back-up ring.

SHAFT

Solid shaft provides alignment and rigid support for disc.

PACKING GLAND

Separate part from gland flange, preventing uneven load distribution against packing.

BEARINGS

Both above and below the disc, bearings maintain shaft alignment. Common materials include:

- Glass-backed TFE for up to 450 °F. (Not for steam service.)
- Luberized Bronze for up to 750 °F.
- 300 Series Stainless Steel Nitrided for up to 900 °F.

DISC SPACERS

Disc is centered by use of thrust spacers around shaft in sizes 2" to 5". Disc position stops or thrust bolt arrangements are used for larger sizes.

BODY

ASME B16.34 design in either wafer or lug configuration.

DISC

360° uninterrupted spherical edge for sealing. Profile is designed for maximum flow and equal percentage control. Disc seating surface is Nitrided for enhanced temperature and abrasion resistance.

RETAINER RING

Retains seat in valve. Standard surface finish is 125 to 250 AARH and is compatible with both standard gaskets and spiral wound gasket designs. Outside diameter is recessed within gasket sealing surface to prevent external leakage.

End Seal Variation

The ASME 150 14" through 24" sizes feature a two-piece shaft design. The lower shaft utilizes an end seal in the body to prevent external leakage. The component parts include an end seal, an end cap and end cap bolts.

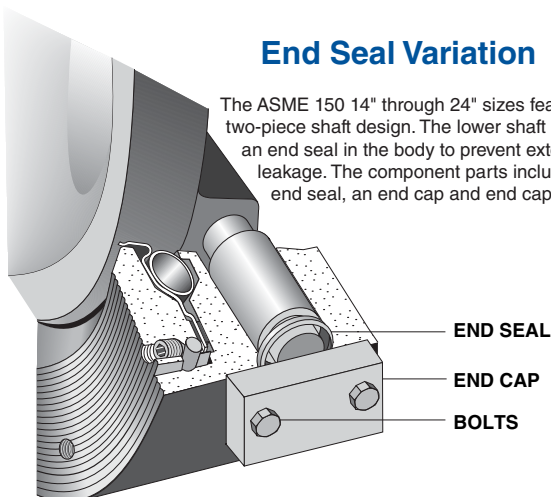

Lower Packing Variation

The ASME 150 30" through 48"; ASME 300 14" through 30"; ASME 600 10" through 16" sizes feature a two-piece shaft design which utilizes a lower packing seal in the valve body to prevent external leakage. The component parts are of the same design used in the packing assembly in the top of the valve body neck.

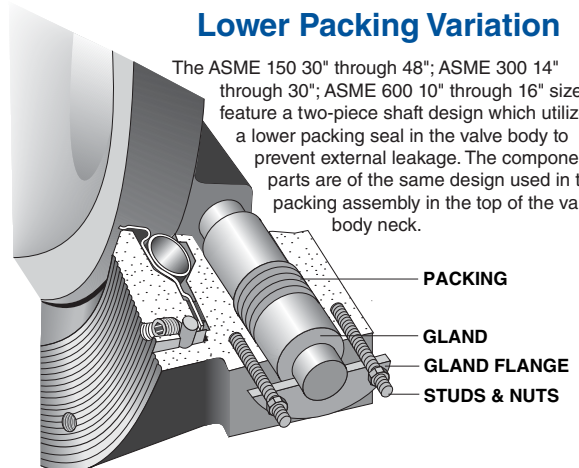

PRESSURE/TEMPERATURE RATINGS

As temperature increases, the pressure retaining capability of materials decreases. The graph below illustrates the pressure/temperature ratings of the Flowseal ASME Class 150, Class 300 and Class 600.

The heavy lines define the ratings of the carbon steel and stainless steel valve body (or “shell”) in conformance to ASME B16.34. The shaded areas define the ratings of the metal seat.

Seat ratings are based on differential pressure with the disc in the fully closed position.

ASME B16.34 Body and Flowseal Metal Seat Pressure - Temperature Ratings
Temperature - C

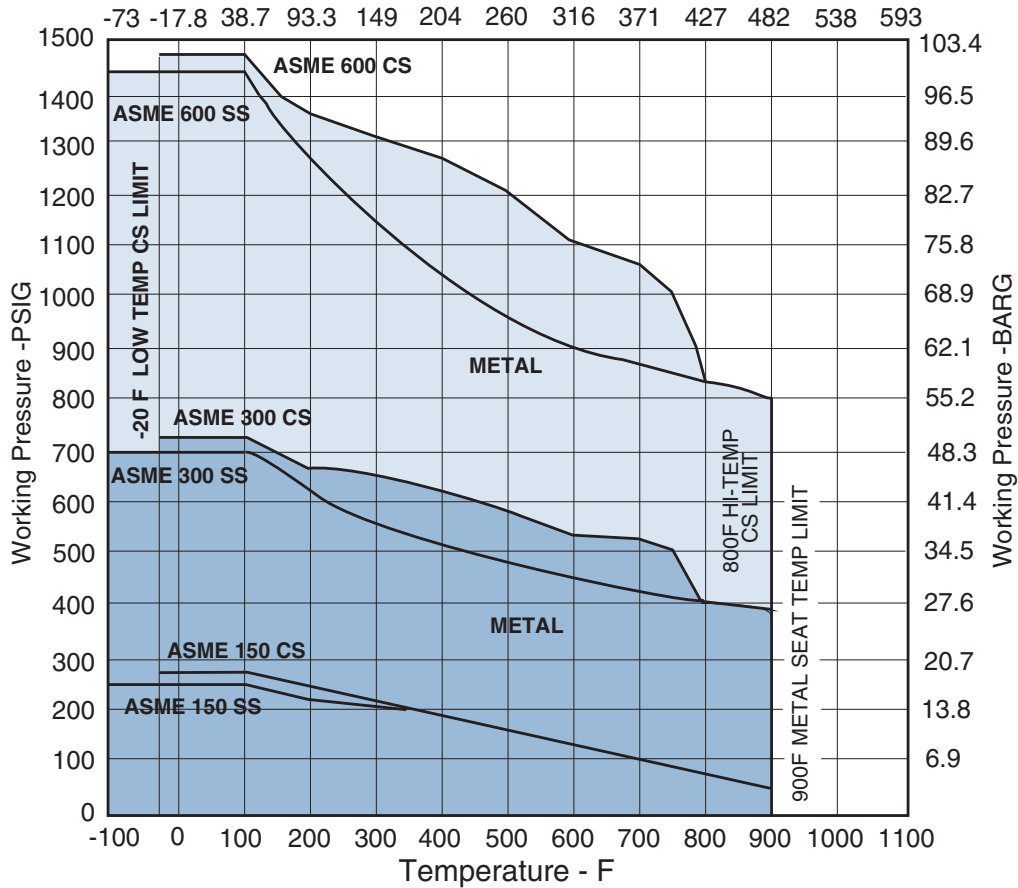

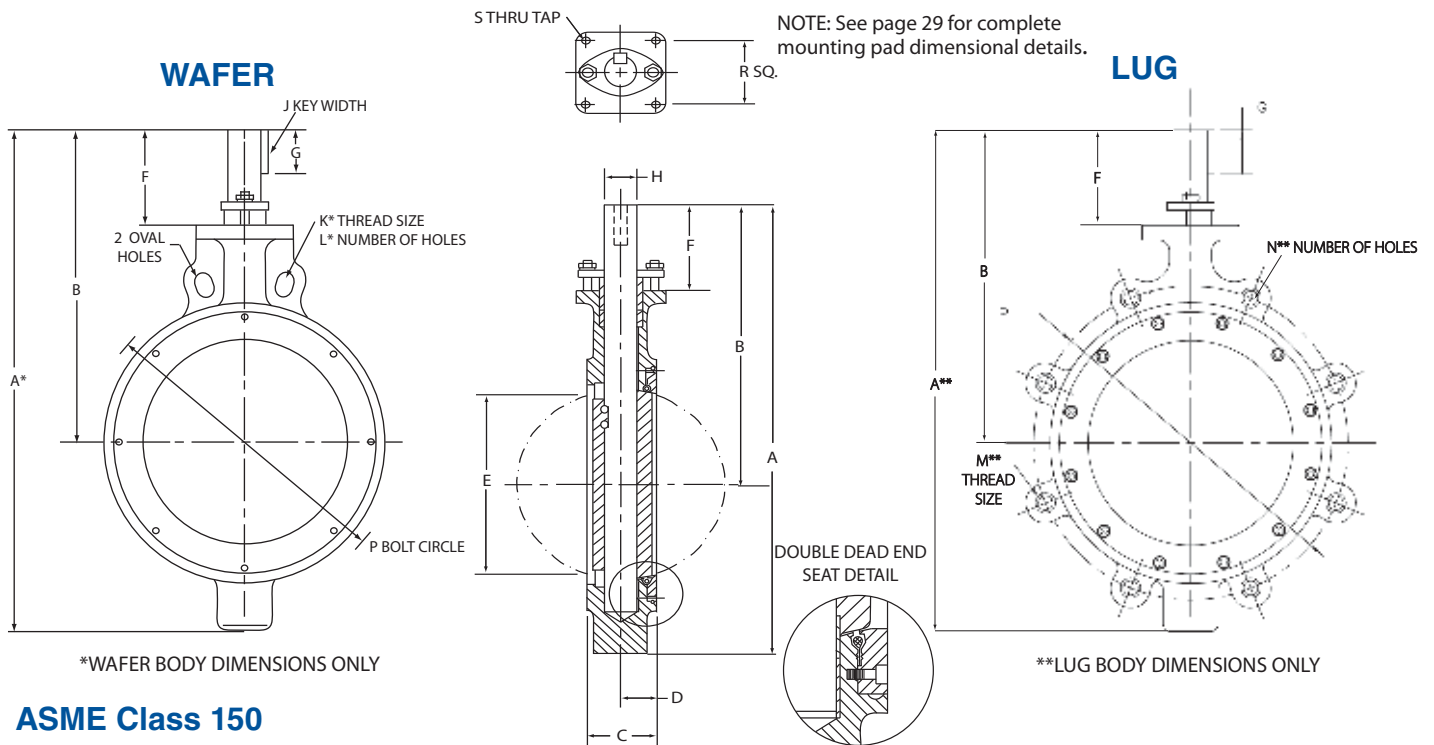

ASME Class 150

VALVE SIZE	WAFER	LUG	B	C	D	E	F	G	H	J	K*	L*	M**	N**	P	R	S	WEIGHT (LBS.)	
	A*	A**																WAFER	LUG
2"	10.59	10.59	7.59	1.75	1.06	1.72	3.34	.88	.500	3/16	-	-	58-11	4	4.750	2.25	38-16	8	11
2.5"	10.30	10.30	7.59	1.88	1.09	2.09	3.34	.88	.500	3/16	-	-	58-11	4	5.500	2.25	38-16	8	11
3"	11.60	11.98	8.60	1.92	1.20	2.75	3.60	1.19	.625	3/16	-	-	58-11	4	6.000	2.25	38-16	11	13
3.5"	11.97	11.97	8.72	2.05	1.30	3.19	3.60	1.19	.625	3/16	-	-	58-11	8	7.000	2.25	38-16	14	17
4"	12.92	13.55	9.42	2.13	1.26	3.62	3.67	1.19	.625	3/16	-	-	58-11	8	7.500	2.25	38-16	17	25
5"	14.53	15.16	10.28	2.25	1.34	4.55	3.81	1.25	.750	1/4	-	-	34-10	8	8.500	2.25	38-16	20	30
6"	15.69	15.93	10.81	2.29	1.38	5.55	3.81	1.25	.750	1/4	-	-	34-10	8	9.500	2.25	38-16	30	35
8"	17.81	17.94	11.93	2.50	1.49	7.28	3.80	1.25	1.000	3/8	-	-	34-10	8	11.750	2.25	38-16	44	48
10"	19.85	20.85	12.97	2.81	1.70	9.20	4.09	1.50	1.250	3/8	-	2	7/8-9	12	14.250	3.25	38-16	71	91
12"	24.96	24.96	15.46	3.23	1.86	11.15	4.83	2.25	1.500	3/8	-	2	7/8-9	12	17.000	3.25	38-16	110	127
14"	27.14	27.14	16.07	3.62	2.19	12.76	4.82	2.25	1.500	3/8	-	4	1-8	12	18.750	3.25	38-16	135	183
16"	31.66	31.66	19.61	4.00	2.31	14.58	6.92	2.50	1.750	1/2	-	4	1-8	16	21.250	4.25	1/2-13	182	250
18"	34.53	34.53	21.35	4.50	2.45	16.38	7.35	3.25	2.000	1/2	-	4	1-1/8-8	16	22.750	4.25	1/2-13	234	305
20"	36.70	36.70	22.76	5.00	2.94	18.38	7.63	3.00	2.250	3/4	1-1/8-8	4	1-1/8-8	20	25.000	5.00	3/4-10	320	414
24"	41.57	41.57	25.13	6.06	3.12	21.88	7.88	3.25	2.500	3/4	1-1/4-8	4	1-1/4-8	20	29.500	5.00	3/4-10	505	702
30"	52.08	52.08	29.35	6.75	3.53	28.00	8.73	4.50	3.000	3/4	1-1/4-8	4	1-1/4-8	28	36.000	5.00	3/4-10	925	1130
36"	64.75	64.75	32.64	8.38	4.34	33.66	8.14	3.50	3.750	1	1-1/2-8	4	1-1/2-8	32	42.750	7.00	1-8	1630	1890

ASME Class 300

VALVE SIZE	WAFER		LUG		B	C	D	E	F	G	H	J	K*	L*	M**	N**	P	R	S	WEIGHT (LBS.)	
	A*	A**	WAFLER	LUG																	
2"	10.59	10.59	7.59	1.75	1.06	1.72	3.34	.88	.500	3/16	–	–	5/8-11	8	5.000	2.25	3/8-16	8	11		
2.5"	10.30	10.30	7.59	1.88	1.09	2.09	3.34	.88	.500	3/16	–	–	3/4-10	8	5.880	2.25	3/8-16	8	11		
3"	11.60	11.98	8.60	1.92	1.20	2.75	3.60	1.19	.625	3/16	–	–	3/4-10	8	6.625	2.25	3/8-16	12	17		
3.5"	11.97	11.97	8.72	2.05	1.30	3.19	3.60	1.19	.625	3/16	–	–	3/4-10	8	7.250	2.25	3/8-16	14	19		
4"	12.92	13.54	9.42	2.13	1.25	3.62	3.67	1.19	.625	3/16	–	–	3/4-10	8	7.875	2.25	3/8-16	17	24		
5"	14.53	15.16	10.28	2.25	1.34	4.55	3.81	1.25	.750	1/4	–	–	3/4-10	8	9.250	2.25	3/8-16	20	30		
6"	15.93	16.31	10.81	2.29	1.38	5.55	3.81	1.25	1.000	3/8	–	–	3/4-10	12	10.625	2.25	3/8-16	30	49		
8"	18.10	19.50	12.22	2.88	1.54	7.06	4.08	1.50	1.250	3/8	–	–	7/8-9	12	13.000	3.25	3/8-16	52	80		
10"	21.60	22.10	14.22	3.25	1.70	9.00	4.84	2.25	1.500	3/8	1-8	2	1-8	16	15.250	3.25	3/8-16	88	115		
12"	28.40	28.40	17.90	3.62	1.86	10.72	6.90	2.50	1.750	1/2	1-1/8-8	4	1-1/8-8	16	17.750	4.25	1/2-13	153	199		
14"	34.31	34.31	19.74	4.62	2.48	12.08	7.36	3.25	2.000	1/2	1-1/8-8	4	1-1/8-8	20	20.250	4.25	1/2-13	285	324		
16"	38.14	38.14	21.82	5.25	2.59	13.72	7.82	3.00	2.250	3/4	1-1/4-8	4	1-1/4-8	20	22.500	5.00	3/4-10	336	401		
18"	40.26	40.26	23.00	5.88	3.03	15.56	7.87	3.25	2.500	3/4	1-1/4-8	4	1-1/4-8	24	24.750	5.00	3/4-10	393	517		
20"	43.62	43.62	25.13	6.31	3.24	17.22	8.74	4.50	3.000	3/4	1-1/4-8	4	1-1/4-8	24	27.000	5.00	3/4-10	510	735		
24"	49.94	49.94	28.27	7.19	3.62	20.61	8.89	4.00	3.500	1	1-1/2-8	4	1-1/2-8	24	32.000	7.00	1-8	733	1020		
30"	62.40	62.40	31.90	8.88	4.39	27.25	9.02	5.00	4.500	1	1-3/4-8	4	1-3/4-8	28	39.250	7.00	1-8	1745	2145		

ASME Class 600

Contact Factory for availability and dimensions.

NOTES:

1. General

- Standard valves tested to MSS SP-61 and ASME/FCI 70-2, Class IV. API 598 testing available on request.
- Dimensions shown are for reference only. Certified drawings available on application.

2. For 2" through 24" sizes:

- Face-to-face dimensions (C) meet, within specified tolerance, MSS SP-68 and API 609 requirements.
- Valves are designed for installation between ASME B16.5 flanges.

3. For 30" through 48" sizes:

- Valves are designed for installation between MSS SP-44 flanges.

STANDARD MATERIALS OF CONSTRUCTION

Carbon Steel Construction

COMPONENTS	-20 °F to 500 °F 171MTG CONSTRUCTION	501 °F to 750 °F 171MGB CONSTRUCTION	751 °F to 800 °F 172MGS CONSTRUCTION
BODY	Carbon Steel A216 Gr WCB, or A105	Carbon Steel A216 Gr WCB, or A105	Carbon Steel A216 Gr WCB, or A105
DISC	316 Stainless Steel A351 CF8M, or A182 F316 Nitrided	316 Stainless Steel A351 CF8M, or A182 F316 Nitrided	316 Stainless Steel A351 CF8M, or A182 F316 Nitrided
SHAFT & PINS	17-4 PH Stainless Steel A564 Gr 630	17-4 PH Stainless Steel A564 Gr 630	316 Stainless Steel* A479 Gr 316
SEAT	Inconel	Inconel	Inconel
PACKING	PTFE	Graphite	Graphite
BEARINGS	Glass-Backed PTFE	Bronze	316 Stainless Steel Nitrided

Stainless Steel Construction

COMPONENTS	-100 °F to 500 °F 271MTG CONSTRUCTION	501 °F to 750 °F 271MGB CONSTRUCTION	751 °F to 900 °F 272MGS CONSTRUCTION
BODY	316 Stainless Steel A351 CF8M, or A182 F316	316 Stainless Steel A351 CF8M, or A182 F316	316 Stainless Steel A351 CF8M, or A182 F316
DISC	316 Stainless Steel A351 CF8M, or A182 F316 Nitrided	316 Stainless Steel A351 CF8M, or A182 F316 Nitrided	316 Stainless Steel A351 CF8M, or A182 F316 Nitrided
SHAFT & PINS	17-4 PH Stainless Steel A564 Gr 630	17-4 PH Stainless Steel A564 Gr 630	316 Stainless Steel* A479 Gr 316
SEAT	Inconel	Inconel	Inconel
PACKING	PTFE	Graphite	Graphite
BEARINGS	Glass-Backed PTFE	Bronze	316 Stainless Steel Nitrided

* Shaft materials other than 17-4 PH or Monel will affect working pressure ratings. Please consult factory.

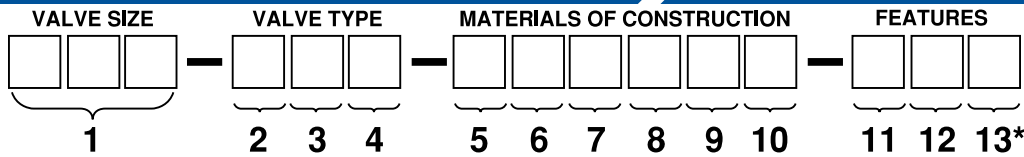

Example: 12 - 1WA - 171MTG - 3: 12" Wafer Style Class 150 Carbon body, Straight 17-4 Ph SS Stem, 316 SS Nitrided Disc, Inconel Seat, TFE Pkg, Garfil Bearings, Gear Operated

1. Size	Code
2"	02
2 1/2"	025
3"	03
3 1/2"	035
4"	04
to	
48"	48

2. Body Class	Code
150 PSI Max. Diff. Pressure	0
ASME 150	1
ASME 300	3
ASME 600	6

3. Body Type	Code
Wafer	W
Lugged	L
Lugged DDES ²	D

4. Shaft Design	Code
Straight	A
Class 150 2" - 12"	
Class 150 36" - 48"	
Class 300 2" - 12" & 30"	
Class 600 2" - 8"	
Balanced	C
Class 150 14" - 30"	
Derated 36" - 48" (150 psig max.)	
Class 300 14" - 24"	
Class 600 10" - 16"	

5. Body Material	Code
Carbon Steel	1
316 SS	2
Monel	3
Alloy 20	4
Annealed AL Br. MIL-B-24480	5
Annealed AL Br. B148 ASTM C958	8
ASTM A744 CN-3MN	A
2205 Duplex ASTM A890 Gr 4A	B
254 SMO	C
Super Duplex ASTM A351 CD4MCu	D
Steel, ASTM A217, Grade C5	E
317 SS	F
Hastelloy C	H
ASTM A352 LCC	L
304 SS (CF8)	N

FLOWSEAL ACTUATOR OPTIONS:

- Lever:** Not recommended for Metal Seat
High Performance Butterfly Valve
- Gear** **Five types available:**
- Operators:**
- High temperature service
 - Buried service
 - Submersible service
 - Marine service
 - Standard aluminum handwheel
- Optional:**
- Chain wheel
 - Output shaft extension
 - Input shaft extension
 - Military special operator
 - AWWA special operator

Hydraulic Actuator:

Customer specified hydraulic actuator

Pneumatic Actuators:

- Crane Revo® spring return pneumatic actuator
- Crane Revo® double acting pneumatic actuator
- Customer specified pneumatic actuator

Electric Actuators:

- Series 44000 electric actuator
- Customer specified electric actuator

6. Disc Material	Code
Alum Bronze/ENP B148 C958	0
316 SS	2
Monel	3
Alloy 20	4
Alum Bronze MIL-B-24480	5
316 SS Nitrided	7
Alum Bronze B148 ASTM C958	8
316 SS/ENP	9
ASTM A744 CN-3MN	A
2205 Duplex ASTM A890 Gr 4A	B
254 SMO	C
Super Duplex ASTM A351 CD4MCu	D
317 SS	F
Hastelloy C	H
Hastelloy C/ENP	J
304SS Nitrided (CF8)	L
Monel/ENP	M
304 SS (CF8)	N

7. Shaft Material	Code
17-4PH SS ¹	1
316 SS	2
Monel ¹	3
Alloy 20	4
Inconel 718/750	6
Ferrallium A479	7
Nitronic 50	0
AL-6XN	A
2205 Duplex ASTM A890 Gr 4A	B
254 SMO	C
317 SS	F
Hastelloy C	H

8. Seat Material / O-Ring	Code
TFE / Viton ⁴	T
TFE / Neoprene	N
RTFE / Silicone ⁵	R
RTFE / Viton ⁴	P
RTFE / AFLAS	O
Polyethylene (UHMWPE) / Viton ⁴	L
Fire-Flow (TFE & Metal) / Viton ⁴	F
Fire-Flow (RTFE & Metal) / Viton ⁴	A
Fire-Flow (RTFE & Metal) / Silicone	B
Inconel	M
300 SS	S
Fire-Flow (TFE & Monel) / Viton ⁴	J
Fire-Flow (RTFE & Monel) / Silicone	C
Fire-Flow (RTFE & Monel) / Viton ⁴	H
Fire-Flow (TFE & Metal) / Silicone	E
Fire-Flow (TFE & Monel) / Silicone	V
Fire-Flow (RTFE & Hastelloy C) / Silicone	K

9. Packing Material	Code
TFE	T
Graphite	G
Fire-Flow	F
Live-Load Packing/TFE	A
Live-Load Packing/Graphite	B
Live-Load Packing/Fire-Flow	C
EF Seal (Viton O-Rings)/TFE	D

10. Bearing Material	Code
Garfil (Glass Backed TFE)	G
316 SS Backed TFE	H
Fire-Flow (Garfil & 316 SS)	F
Stainless Steel Nitrided	S
Bronze	B
Monel	K
Hastelloy C Backed TFE	J

11. Actuator Type	Code
Bare Shaft	B
Worm Gear w/2" Square Nut & Hndwl	D
Ratchet Handle	H
Ratchet Handle w/Lock	L
Throttle	T
Worm Gear	3
Worm Gear (4-way keyed)	9
Pneumatic Double Acting	4
Pneumatic SR Fail Close	5
Pneumatic SR Fail Open	6
Hydraulic	7
Electric	8

12. Special Feature	Code
None	O
Level 2 Commercial Oxygen Cleaning	A
Bi-directional	B
Chlorine Service	C
Dead-end Service (DDES) ²	D
CE Marked (impact tested) ³	PI
CE Marked (non-impact tested) ³	PN
CE Marked (impact tested w/ vacuum service) ³	VI
CE Marked (non-impact tested w/ vacuum service) ³	VN
EF Seal (low emissions)	E
EF Seal Vacuum Service (low emissions)EV	E
Flat Face	F
Silicone Free	G
Epoxy Coated Body	H
Chainwheel	J
Stem Extension	K
Lockable Gear	L
Limit Switch w/Stainless Steel Bolting	L1
Limit Switch w/Monel Bolting	L2
Mil-V-24624	M
Gear with Memory Stop	MS
NACE Construction ⁵	N
NACE Construction	NI
(w/CE marked impact tested) ^{3,5}	
NACE Construction	NN
(w/CE marked NON-impact tested) ^{3,5}	
Buried Service	R
60 to 125 AARR Facing	S
Drill Through Lugs	T
Drill Through Lugs and NACE Constr.	TN
Vacuum Service	V

13. Series	Code
*Factory Assigned	J

- Note¹** Shaft materials other than 17-4 PH or Monel will affect working pressure ratings. Please consult factory.
- Note²** DDES = Double Dead End Service.
- Note³** For CE marked valves, see Body Rating chart on page 28, as temp ranges can vary per material.
- Note⁴** Viton O-Ring is recommended for use in Hydrocarbon and NACE service.
- Note⁵** RTFE/Silicone combination is not to be used with "NACE" valves.