

**PBV<sup>®</sup> SERIES 5700/6700 THREE-PIECE  
TRUNNION SUPPORTED BALL VALVES ▶ ▶ ▶**

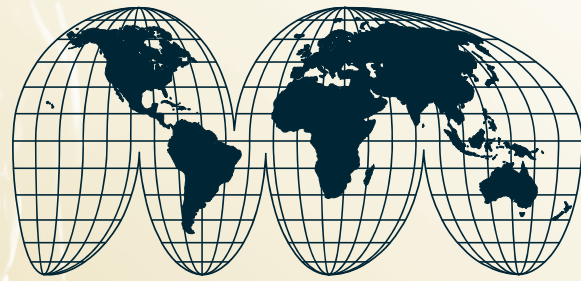



## MANUFACTURER OF QUALITY VALVE PRODUCTS AROUND THE GLOBE

At Forum™ Energy Technologies we are committed to improving our clients' operational and financial performance by supplying the most comprehensive range of valve products in the industry through our family of trusted valve brands.



### ENGINEERING EXPERTISE

Forum™ utilizes the latest state of the art engineering software to provide custom design services for any application. Finite element analysis is just one of many Design Verification Tools FET uses for designing valves to specific customer requirements.



### CAD & NC CAPABILITIES

With FET's fast and efficient workflow, CAD drawings can be released to the network for manufacturing and purchasing. All computer generated machine programs can be quickly changed for weld overlays or other processes. The result is faster deliveries.



### ACCURATE INVENTORIES

Daily cycle counting & order picking using wireless barcode guns and automated part delivery systems results in more accurate inventories and faster product delivery.



### QUALITY CONTROL

All FET Companies manufacture quality products designed and tested to meet the standards of Qualifying Authorities around the world. Advanced engineering and our Quality Management System assure that our valve products continue to exceed your expectations for performance.



### CUSTOMER SERVICE

Forum™'s Customer Service Department is fully staffed with trained customer service representatives ready to help you with your ordering information, technical specifications and logistics.

For more information about our products and full Terms & Conditions please visit [www.f-e-t.com](http://www.f-e-t.com).

Toll Free: 1.800.231.3530



Licensed for manufacture in accordance with API 6A-0383 and API 6D-0129 and fire tested to API 6FA and 607



# CONTENTS ▶▶▶

## Series 5700/6700 Trunnion Supported Ball Valves

Product Range .....	3	<b>MEDIUM BORE VALVES</b>
How to Order .....	4	<b>SERIES 5700</b>
How To Measure for Stem Extensions ...	4	<b>8"-14"RP CL 150, 300, 600, 900 &amp; 1500</b>
Flow Coefficient (C <sub>v</sub> ) .....	5	<b>6"-12"RP CL 2500</b>
How To Read A PBV® Name Plate .....	5	<b>SERIES 6700</b>
Design Features.....	6-10	<b>6"-12"FP CL 150, 300, 600, 900 &amp; 1500</b>
Options .....	11	<b>6"-10"FP CL 2500</b>
MSA Special Services .....	12	Parts List .....
Design Standards and Specifications ..	13	Dimensional Data .....
		19 20-21
<b>PARTS AND DIMENSIONAL DATA</b>		<b>SERIES 5700/6700 LARGE BORE VALVES</b>
<b>SERIES 6700 SMALL BORE VALVES, LOW PRESS.</b>		<b>14"FP - 56"FP CL 150, 300, 600, 900 &amp; 1500</b>
<b>2"-4" CL 150 • 2" CL 300</b>		<b>12" CL 2500</b>
Parts List .....	14	Parts List .....
Dimensional Data .....	15	Dimensional Data.....
		22 23-26
<b>SERIES 5700/6700</b>		<b>ANSI TOP WORKS DATA</b>
<b>SMALL BORE VALVES, HIGH PRESSURE</b>		Series 5700/6700.....
<b>2"FP - 6"RP CL 150, 300, 600, 900, 1500 &amp; 2500</b>		27-29
Parts List .....	16	<b>ADDITIONAL INFORMATION</b>
Dimensional Data .....	17-18	Bore Sizes and Shipping Information ..
		Temp. Conversion Chart .....
		31

Due to upgrades in industry standards, material innovations, and PBV®'s constant commitment to product advancement, data presented in this brochure is subject to change. Please contact your PBV® sales person for updated and/or current drawings and material compliance.

This information is available on our website at [www.f-e-t.com](http://www.f-e-t.com).



## Product Range • Series 5700/6700 Three-Piece Trunnion • Forged

PRODUCT RANGE, SERIES 5700/6700, FULL & REDUCED PORT, FLANGED ENDS

BODY MATERIAL	CLASS		PORT	SIZE (IN.)												
	API 6D	API 6A		2*	3	4	6	8	10	12	14	16	18	20	24	26-56
Carbon Steel & Stainless	150	—	Full & Reduced	X	X	X	X	X	X	X	X	X	X	X	X	X
	300	—		X	X	X	X	X	X	X	X	X	X	X	X	X
600	—	X		X	X	X	X	X	X	X	X	X	X	X	X	X
900	2000	X		X	X	X	X	X	X	X	X	X	—	—	—	—
1500	3000	X		X	X	X	X	X	X	X	X	—	—	—	—	—
2500	5000	X		X	X	X	X	X	X	X	—	—	—	—	—	—
Special	—	10,000	X	X	X	X	X	X	X	—	—	—	—	—	—	

\* Full Port only.

Sizes and classes not listed are available upon special request.



# HOW TO ORDER ▶▶▶

## Specifying Series 5700/6700 Valve Figure Numbers

**Example: 6" C-6710-71-2200-GV-NG** This number represents a 6" ANSI Class 150, Full Port, Three-Piece Trunnion Ball Valve, Fire Tested with Emergency Grease Seals, with Raised Face, Carbon Steel Body Material, Carbon Steel Trim, Glass Filled TFE Seats, Viton®A Seals, for NACE MR0175/ISO 15156 Service and Gear Operated.

**C - 6 7 10 - 7 1 - 22 00 - G V - N G -**

MAT. CODE	PORT CONFIG.	VALVE TYPE	PRESS. CLASS	FIRE TESTED	END CONN.	BODY MAT.	TRIM MAT.	SEAT MAT.	SEAL MAT.	NACE OPTION	OPER.	MODIFIER CODE
<b>C</b>	<b>5</b>	<b>7</b>	<b>10</b>	<b>3</b>	<b>1</b>	<b>22*</b>	<b>00</b>	<b>G</b>	<b>B</b>	<b>N</b>	<b>A</b>	<b>EXX</b>
Carbon Steel	Std.	3 Pc. Trunnion Type Bolted Body	150 CL	Fire Tested w/No Emerg. Grease Seals	RF	A105/A350LF2	Same as Body	Glass Filled PTFE	Buna-N EPDM	NACE	Actuator	Stem Exten. inches
<b>S</b>	<b>6</b>	<b>9</b>	<b>30</b>	<b>7</b>	<b>2</b>	<b>25*</b>	<b>36<sup>(3)</sup></b>	<b>D</b>	<b>E</b>	<b>S</b>	<b>B</b>	<b>XXX</b>
Stainless Steel	Full	3 Pc. Trunnion Type Welded Body	300 CL	Fire Tested w/Emerg. Grease Seals	Non-Std.	A105/A350LF2	Stainless Steel	PTFE	EPDM	Non NACE	Bare Stem	inches
			<b>60</b>		<b>3</b>	<b>34</b>	<b>55</b>	<b>N</b>	<b>R</b>		<b>G</b>	<b>XXX</b>
			600 CL		RTJ	F55	F55	Nylon	HNBR		Gear Operator	Modifier Code
			<b>90</b>		<b>4</b>	<b>36</b>	<b>71</b>	<b>P</b>	<b>T<sup>(1)(2)</sup></b>		<b>L</b>	
			900 CL		RF x WE	316SS	Duplex	Temp	Low		Lever	
			<b>15</b>		<b>5</b>	<b>55</b>	<b>55</b>	<b>V</b>	<b>T<sup>(1)(2)</sup></b>			
			1500 CL		WE x WE	F55	Monel®	Lip Seal	T <sup>(1)(2)</sup>			
			<b>25</b>		<b>6</b>	<b>81</b>		<b>Viton®A</b>	<b>PTFE</b>			
			2500 CL		RTJ x WE	Duplex		Viton®A	PTFE			
						<b>82</b>		<b>Z</b>	<b>V</b>			
						ENP		Tungsten Carbide Coating or Special	Viton®A			
						<b>82</b>			<b>W<sup>(2)</sup></b>			
						CRA			Viton® B			
						Weld Overlay						

**NOTES:**

- 1) For Low Temperature Service & Severe Service.
  - 2) For Explosive Decompression Service. Other body, trim, seat and seal materials are available upon request.
  - 3) For "36" trim, large diameter and Class 900 and higher, 17-4PH material is standard for ball and stem. All valves 6" and larger have 17-4PH stems when "36" trim is specified. Stronger material may be used to satisfy design requirements. Stems can be 316SS, S20910, 17-4PH, etc.
- \*Dual rated A105/A350 LF2

### How to Measure for PBV® Stem Extensions

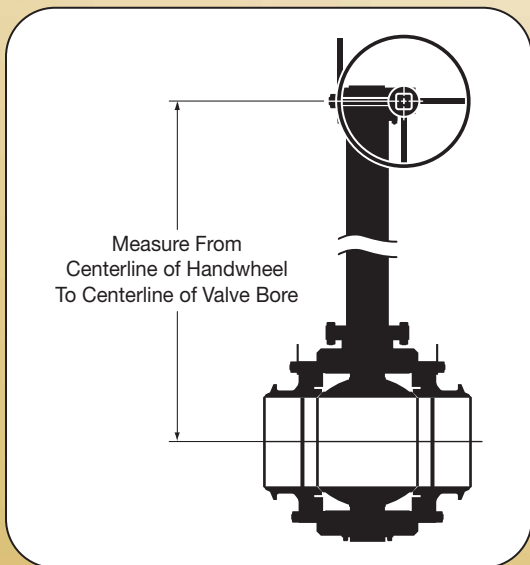

- Take measurement from centerline of valve bore to handwheel centerline as illustrated here.
- Body vent drain and emergency sealant lines are extended with the stem.



# FLOW COEFFICIENTS (C<sub>v</sub>) ▶▶▶

## Series 5700/6700 • Flow Coefficients (C<sub>v</sub>) For PBV® Trunnion Ball Valves

C<sub>v</sub>, by definition, is the volume of water in gallons per minute at 60°F that will flow through a given element with a pressure drop of 1 psi.

SIZE (IN.)	FLOW COEFFICIENTS (C <sub>v</sub> ) RATING					
	CL 150	CL 300	CL 600	CL 900	CL 1500	CL 2500
2x2	500	460	400	330	330	300
3x2	180	195	180	187	187	150
3x3	1350	1150	1050	935	830	740
4x3	545	535	550	510	510	410
4x4	2500	2200	1850	1760	1660	1460
6x4	790	765	745	740	740	590
6x6	5300	5290	4460	4405	4100	2600
8x6	1945	1945	2220	2035	1930	1400
8x8	10,500	9600	8730	8475	8010	5370
10x8	4050	4040	4065	4050	3860	3050
10x10	17,500	16,750	14,250	14,205	13,310	8630
12x10	6900	7100	7050	7025	6670	5350
12x12	26,300	25,500	22,550	21,430	17,070	12,500
14x12	13,100	13,200	13,350	13,300	12,630	—
14x14	31,850	30,050	28,400	26,800	24,275	—
16x14	14,600	14,580	14,300	14,200	13,490	—
16x16	43,300	41,700	38,150	36,700	33,215	—
18x16	19,750	19,800	20,350	19,750	18,760	—
18x18	57,300	55,370	50,950	48,700	43,400	—
20x18	27,750	28,050	28,300	27,300	20,470	—
20x20	74,500	72,300	65,600	62,500	55,930	—
24x20	27,100	27,130	27,250	26,900	25,500	—
24x24	112,300	109,150	98,150	94,050	84,025	—
26x24	85,270	82,470	77,630	67,880	53,190	—

SIZE (IN.)	FLOW COEFFICIENTS (C <sub>v</sub> ) RATING					
	CL 150	CL 300	CL 600	CL 900	CL 1500	CL 2500
26x26	116,800	111,900	103,750	93,240	71,670	—
28x24	62,590	61,470	59,380	53,880	43,750	—
28x28	136,850	131,600	122,650	112,200	84,220	—
30x24	49,980	49,390	48,030	44,540	37,130	—
30x30	161,700	155,650	143,200	131,500	98,390	—
32x30	143,600	137,400	128,600	116,950	90,690	—
32x32	182,650	173,300	160,450	151,250	113,800	—
34x30	109,950	107,050	101,950	94,300	76,200	—
34x34	207,800	197,800	181,550	172,950	129,550	—
36x30	90,830	88,660	85,210	78,690	65,010	—
36x32	127,750	123,350	116,650	112,150	88,850	—
36x36	233,600	219,450	199,800	197,600	145,950	—
40x36	160,850	160,850	157,250	148,650	—	—
40x40	282,300	282,300	271,550	248,400	—	—
42x40	265,250	265,250	253,450	232,050	—	—
42x42	312,350	312,350	297,100	275,550	—	—
44x40	218,100	218,100	209,800	196,700	—	—
44x44	351,600	351,600	331,000	306,400	—	—
46x46	379,700	379,700	358,450	352,400	—	—
48x42	201,050	201,050	196,400	187,150	—	—
48x44	275,950	275,950	266,850	248,200	—	—
48x48	412,500	412,500	393,150	373,200	—	—
56x56	605,150	605,150	587,750	—	—	—

### How to Read a PBV® Name Plate

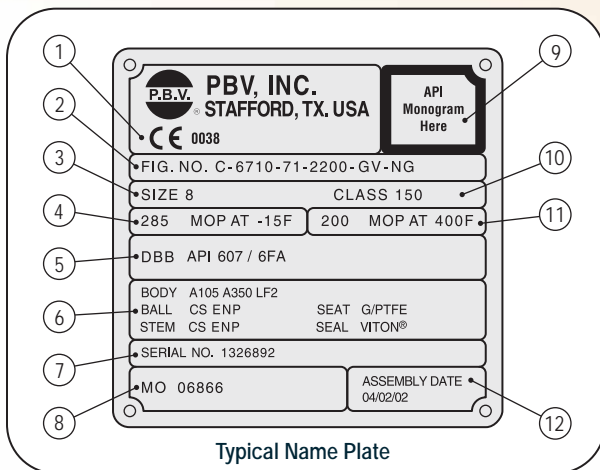

ITEM	DESCRIPTION
1	CE mark and notified body required for delivery to EEC.
2	Figure number describes valve construction.
3	Nominal pipe size in inches
4	Max. operating pressure at min. valve design temp.
5	Valve features double block and bleed (DBB) and firesafe standards.
6	Body and trim materials
7	PBV® serial number
8	PBV® manufacturing order
9	API 6D or 6A monogram stamp
10	ANSI Pressure Class
11	Max. operating pressure at max. valve design temp.
12	Date of assembly MM/DD/YY

### PBV® REPAIR KITS

Spare parts are available for quick delivery. Orders with valve serial numbers will ensure the correct parts are shipped. Contact your PBV® salesperson for more information.

### OUR QUALITY COMMITMENT...

Forum™ Energy Technologies is dedicated to continually improving their state-of-the-art engineering and manufacturing capabilities to improve the overall quality of their products and customer service. FET's entire global network of flow control experts consist of highly trained technicians, engineers, and superior testing laboratories to ensure that all products supplied to our customers are 100% in accordance with industry standards as well as our own Quality Management System.



# PBV® ENGINEERING EXCELLENCE AT WORK ▶▶▶

## The PBV® Series 5700/6700 Three - Piece, Side-Entry, Trunnion Ball Valve 2" - 56" ANSI Class 150/300, 600, 900, 1500 & 2500 • In Full and Standard Port

PBV®'s trunnion ball valves are available in a variety of materials and configurations to meet your specific project requirements. Typical construction is shown here.

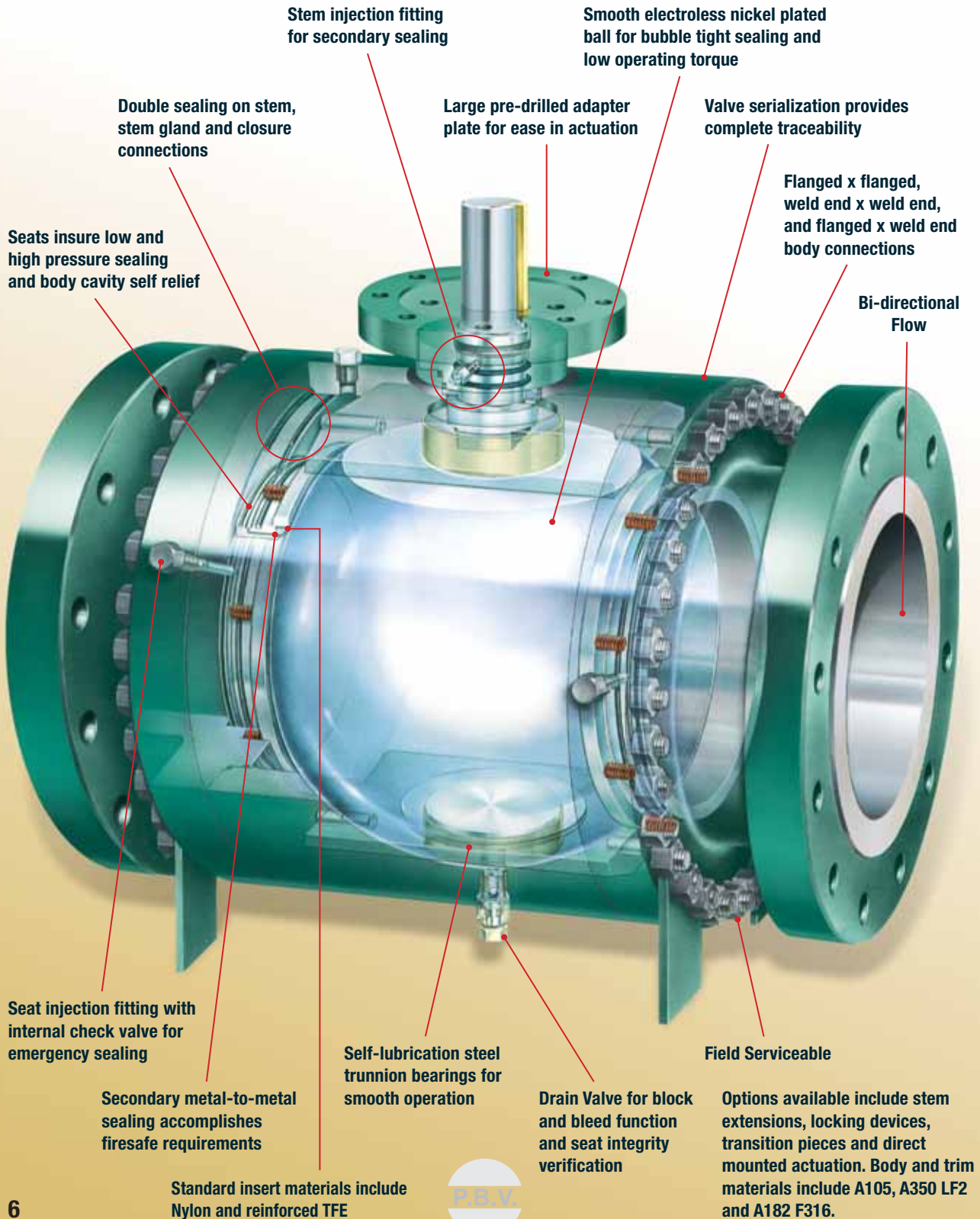

## FEATURES ▶ ▶ ▶

### Materials of Construction

PBV® manufactures trunnion ball valves using a full range of carbon, alloy and stainless materials. Our commodity valves are manufactured using dual rated A105/A350 LF2 steel, B7M/2HM fasteners, and 3 mil ENP carbon steel trim on 6" and larger. Material test reports in accordance with EN10204 3.1b are available on each serialized valve.

### NACE COMPLIANCE

The demand for valves to be resistant to sulfide stress cracking, and to perform in corrosive hydrocarbon environments, has become commonplace. Facilities handling H<sub>2</sub>S bearing hydrocarbons have increased dramatically over recent years. Hydrogen sulfide concentration, total system pressure, application temperature, existence of elemental sulfur, and chloride content all have a bearing on appropriate material selection in this severe environment.

All materials used by PBV® are in accordance with the pre-qualified materials identified in NACE MR0175/ISO 15156. In order to ensure compliance customers must provide application specific operating conditions.

Inclusive to the above, valves with bore diameters 4" and smaller are supplied standard with Stainless Steel balls, seats and stems. Material type selected may vary depending on design requirements.



### EMERGENCY SEALANT INJECTION

A secondary sealant injection system for stem seals is a standard feature on all PBV® Trunnion ball valves. On valves 6" bore and larger, the seat emergency sealant system shown here is a standard feature. A similar system is available for sizes 2" thru 4" on request.

These systems are made available for the sole purpose of providing a temporary seal to an otherwise damaged area. PBV® ball valves require no lubrication under ordinary circumstances.

### ANTI-BLOWOUT

Blowout proof stems are a standard feature of all PBV® ball valves.

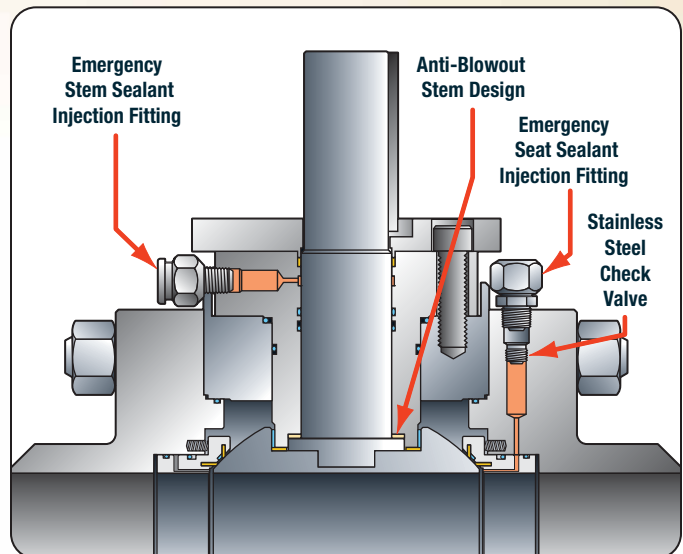

# FEATURES ▶▶▶

## PBV®'s Patented Seat Technologies

PBV® provides the latest in valve seat technology, leading the industry with the patented Comp II seat. Other seat designs are also available to meet your application requirements. This makes PBV® one of the most flexible manufacturers in terms of

available seat configurations and designs. PBV®'s metal-to-metal seating technologies and manufacturing capabilities continue to lead the way in industry innovations where severe service applications are required.

### COMPSEAL - 0

The PBV® Compseal-0 design is ideal for applications where non-standard seat materials are required for the service conditions. The different materials give added flexibility for faster delivery in demanding applications. The seat inserts allow for a variety of materials to be used while still complying to API seat test requirements for "bubble-tight shut-off". Nylon Compseal-0 designs are standard on sizes 14" and larger.

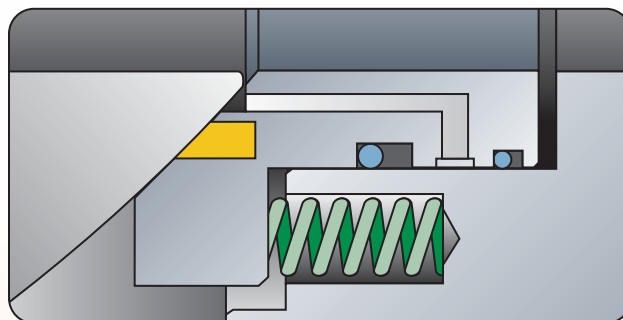

### COMPSEAL - 1

PBV® Compseal-1 seat designs are for applications that require redundant sealing when access to a valve is limited or start up conditions are known to have debris in the line. Lower torque and low pressure shut-off are often achieved utilizing this design while providing customers with zero leakage reliability at an affordable price.

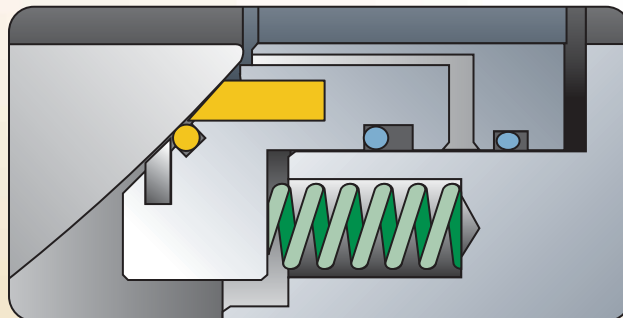

### METAL - TO - METAL SEATS

There are a number of services that require metal-to-metal seat technology. PBV® has extensive experience in the supply of valves for applications such as high temperature cokers, control valve applications and in corrosive and/or erosive environments. PBV® achieves the metal-to-metal seating technology through the use of various hard face material on the ball and seat face.

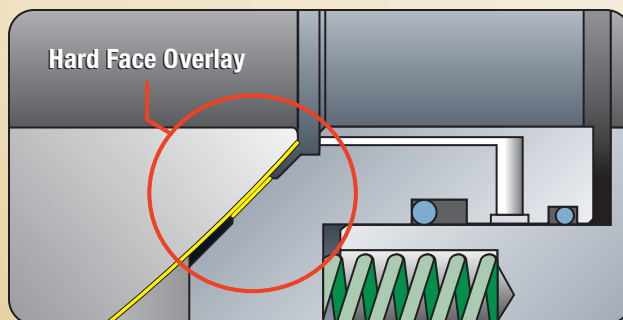



## FEATURES ▶ ▶ ▶

### LOCKING DEVICES

Locking devices are standard on all PBV® trunnion ball valves. The designs shown depict the locking feature for both lever-operated and gear-operated valves. In addition, a multiple lock template can accommodate safety requirements when more than one person needs reassurance of security. Special safety interlock devices are also available.

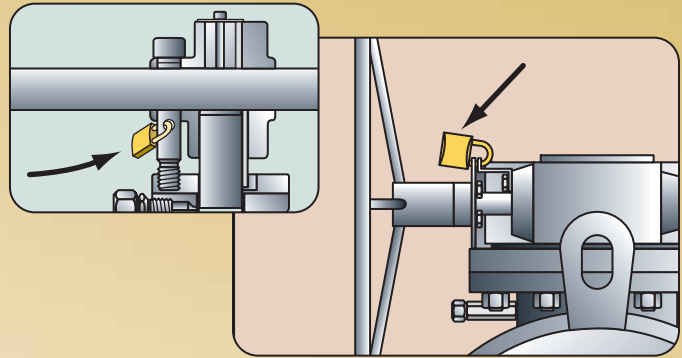

### ACTUATION

PBV® ball valves are built to easily accept pneumatic, electric, hydraulic or gas-over-oil actuators. Break-away and run torque, which normally affect actuator sizing, are minimized to allow for economical actuator packages. Actuated ball valves may be supplied directly from PBV® under a single warranty.

Valve/Actuator assemblies can be tested to customer requirements at PBV® before shipment to the job site.



The valves shown above are just a few of many severe service ball valves PBV® produced for the United States Department of Energy, Strategic Petroleum Reserves, complete with gear operators built and tested to DOE specifications.

### WELD OVERLAY TECHNOLOGY

This technology is cost effective for ball valves in highly corrosive or erosive services. The life of a valve can be considerably extended at a fraction of the cost of a solid corrosion resistant alloy valve by the application of a weld overlay to valve internal surfaces.

If you are currently using solid stainless steel or other high alloy valves the use of this technology could result in considerable savings with no sacrifice to service life or performance. Offered on valves 6" and larger.

Welding is performed in accordance with ASME BPV Section 9.



## FEATURES ▶ ▶ ▶

### DOUBLE BLOCK AND BLEED VALVES

All PBV® trunnion mounted ball valves are designed and manufactured to facilitate block and bleed applications in the closed position only. In addition, valves 6" and larger can be completely flushed with the valve under pressure and in the closed position. This is achieved by utilizing the drain valve and vent hole in combination. The illustration shows both the upstream pressure ( $P_u$ ) and the downstream pressure ( $P_d$ ) being held independently from the body pressure ( $P_b$ ). The piston effect principle illustrated assures bubble tight sealing simultaneously on both sides of the ball.

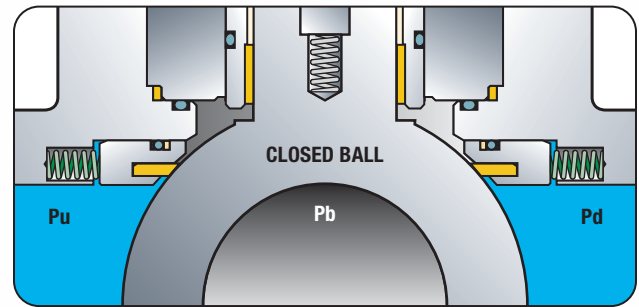

Shown In Closed Position.

### VALVE CAVITY PRESSURE RELIEF

When a trunnion ball valve is in the closed position, media will be trapped in the body cavity. Unless this media is drained, it will be subjected to thermal expansion and contraction. As the temperature rises, the trapped media desires to expand and the pressure increases in the area shown as ( $P_b$ ). In order to avoid excessive pressure build-up, the PBV® seats are designed to self-relieve, allowing the media in the body to escape to the pipeline. In this case, we have shown it to relieve to the downstream side ( $P_d$ ). This self-relieving seat design feature is standard on all PBV® trunnion ball valves.

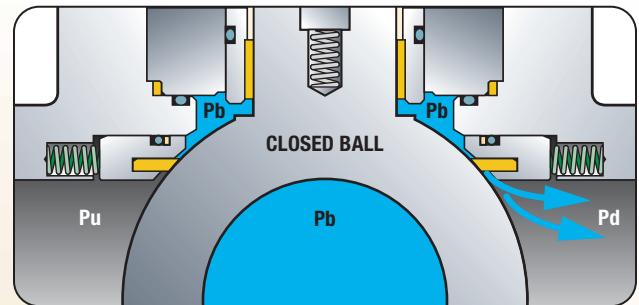

Shown In Closed Position.

# OPTIONS ▶▶▶

## BURIED SERVICE

The photos and illustrations shown here typify the designs used for adapting a PBV® ball valve for buried service. PBV® manufactures hi-head



extensions exactly in accordance with customer specifications or according to our own engineering and manufacturing designs.

**PBV® has the capabilities to produce giants like the one pictured at right. PBV® produced two 48" Class 600 ball valves with 96" extended stems for the Williams Energy, "Sun-dance Pipeline Project."**



## PBV® BALL VALVES FOR CRYOGENIC SERVICE

For service temperatures below -50° F, PBV®'s standard design includes lip seals and stem extensions using selected materials for your application. The 12" gas column shown at right is a standard feature to isolate the gear operator and stem seals from the cold media.

**PBV® provides extended stems which are used in a variety of applications.**

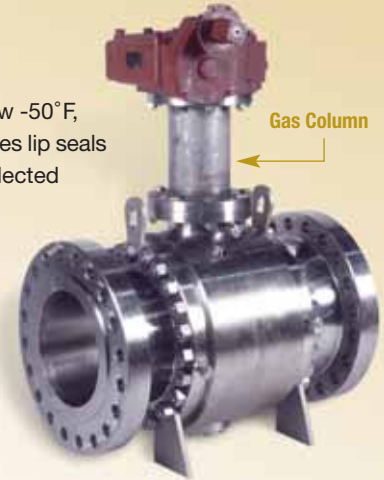

**Subsea Valve**



**Splash Zone Valve**

PBV® supplies subsea valves to individual customer requirements or to our own internal standards. Coatings, fastener protection, gear boxes with pressure equalizing devices, protected drive stems and customized ROV couplings are all components of design considered for PBV® ball valves being used in subsea service.



# LARGE DIAMETER SPECIAL FEATURES ▶ ▶ ▶

## SEAT DESIGN

The necessary thrust required for proper sealing of the seat to the ball at low pressure is provided by spiral springs (See Illustration 1). At high pressure the thrust of the seat to the ball is increased by the pressure of service medium in the pipeline. Primary seat sealing is provided by a soft sealing ring of different rubber types. Alternatively, a PTFE hard sealing ring (or PTFE modifications) can be used for primary sealing. Secondary sealing is provided by metal-to-metal contact of the seat to the ball. Emergency sealant, which can be injected between the seat and ball, can be used as tertiary sealing. Seats with soft sealing rings are automatically supplied as DPE design (See Illustration 2). DPE design means, that if the upstream seat is damaged, function of a ball valve is still secured by a downstream seat.

## TWO-WAY DOUBLE ACTING

To meet customers requirements, often times a two-way seat design is required. This design allows for downstream seat sealing in the case of an upstream seat failing to seal. This design also provides for the function of testing a valve in-line and in full open position with the drain or bleed valve open to the air.

## FULLY WELDED BODY DESIGN

Fully welded three-piece body designs are available in larger sizes.

## SPECIAL UNDER WATER GAS TESTING

Valves can be air or gas tested under water in a special chamber.

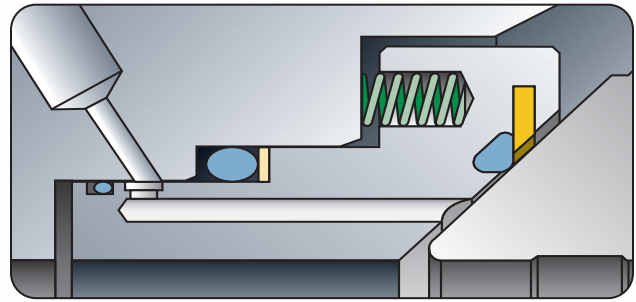

Illustration No. 1

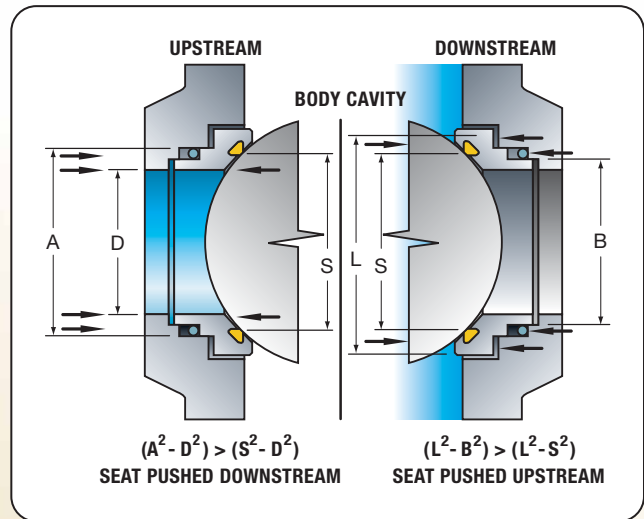

Illustration No. 2



# DESIGN STANDARDS AND SPECIFICATIONS ▶ ▶ ▶

Valve designs covered in this catalog conform to the following industry standards and specifications.

## AMERICAN PETROLEUM INSTITUTE

- API 6D** • Specifications for pipeline valves
- API 607** • Fire test for soft-seated ball valves (Div. of Refining)
- API 6FA** • Fire test for valves (Div. of Production)
- API Q1** • Specifications for quality programs
- API 6A** • Specifications for Wellhead and Christmas Tree Equipment.

## MANUFACTURERS STANDARDIZATION SOCIETY

- MSS SP-25** • Standard marking system for valves
- MSS SP-55** • Quality Standard for Steel Castings

## NATIONAL ASSOC. OF CORROSION ENGINEERS

- NACE MR0175 2002** • Sulfide stress cracking resistant metallic materials for oilfield equipment

## AMERICAN NATIONAL STANDARD

- ASME/ANSI B 16.10** • Face-to-face and end-to-end dimensions on ferrous valves
- ASME/ANSI B 16.5** • Steel pipe flanges and flanged fittings
- ASME/ANSI B 16.34** • Steel valves-flanged and butt-weld end
- ASME/ANSI B 31.1** • Chemical plant and petroleum refinery piping
- ASME B 31.4** • Liquid petroleum transportation piping systems
- ASME B 31.8** • Gas transmission and distribution piping systems

## CODE OF FEDERAL REGULATIONS

- Title 49-Part 192** • Transportation of natural and other gas by pipeline: Minimum federal safety standards

## EUROPEAN COMMUNITY

Pressure Equipment Directive 97/23/EC



## Certification of Quality and Design

Quality systems are a way of life at PBV®. In addition, PBV® functions under the requirements of an API Q1 quality program. Our facilities and quality programs are always open to customer audits.

The complete PBV® trunnion ball valve line has been designed and tested to ensure that the external and through-bore maximum allowable leakage rates are maintained in the event of a fire. PBV® has equipment and facilities to firesafe test our products to the edition of API 607 and API 6FA firesafe standards.

API 6D



API 6A



ISO 9001:2000



All API 6D, API 6A, CE PED and other licenses are maintained on a current basis. Each and every PBV® trunnion ball valve is monogrammed and serialized under our API 6D-0129 or our API 6A-0383 license numbers.



X-ray testing and evaluation of castings are performed at PBV®'s Engineering and Testing Facility in Stafford, Texas.



Pressure Testing Stations and Qualified Personnel are utilized to provide consistent compliance to industry test criteria for every valve.

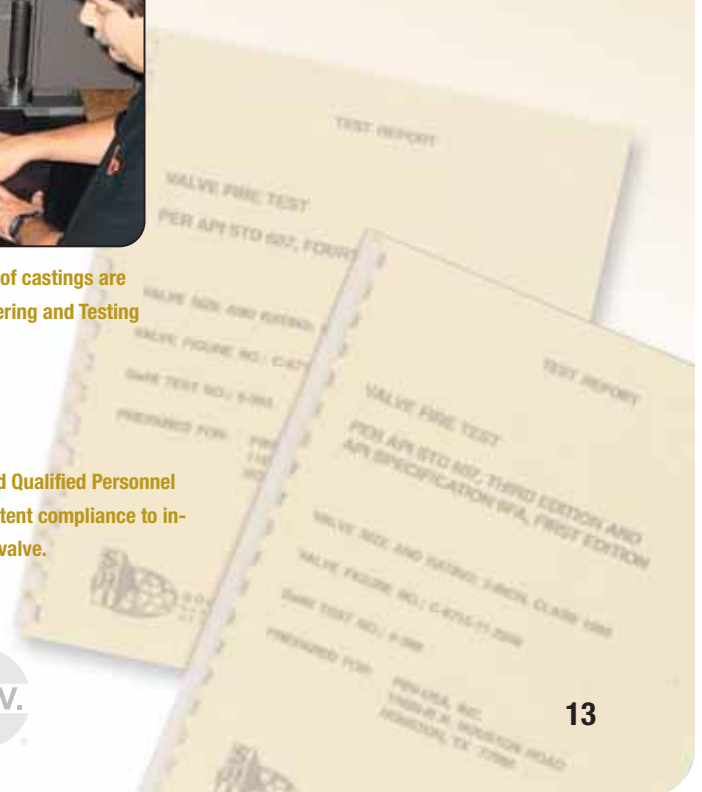

# PARTS FOR LOW PRESSURE SMALL SIZE DIAMETER VALVES ▶▶▶

Series 6700 • 2" - 4" Class 150 • 2" Class 300

NO.	DESCRIPTION	MATERIAL	SPARES
1	Body	A105/A350 LF2	
2	Closure	A105/A350 LF2	
4	Ball	316SS	
5	Stem	316SS	
6	Seat Ring Sub Assembly	316SS- G/PTFE	S
9	Trunnion	4130 ENP	
10	Gland	4130 ENP	
12	Adapter Plate	A36	
20	Stem Key	Carbon Steel	
25	Stem Thrust Washer	Graphite	S
28	DU Bearing	DU Dry Bearing	
31	Seat/Stem Spring	X-750	
32	Body O-ring	Viton®	S
33	Seat O-ring	Viton®	S
34	Stem O-ring	Viton®	S
35	Gland & Trunnion O-ring	Viton®	S
39	Body Cap Screw	A574 Modified	
43	Gland Cap Screw	A574 Modified	
44	Adapter Plate Cap Screw	A574 Modified	
45	Trunnion Cap Screw	A574 Modified	
46	Stem Key Cap Screw	Carbon Steel	
49	Stem Grease Fitting	Carbon Steel	
50	Body Grease Fitting	Carbon Steel	
51	Check Valve	Stainless Steel	
54	Drain Valve	Carbon Steel	
60	Handle	Carbon Steel	
62	Indicator Screw	Carbon Steel	
63	Retainer Washer	Carbon Steel	
64	Name Plate	Stainless Steel	
65	Drive Screw	Stainless Steel	
67	Handle Adapter	Carbon Steel	
69	Lock Screw	Carbon Steel	
70	Body Gasket	Graphite	S
71	Gland & Trunnion Gasket	Graphite	S
72	Stem Packing	Graphite	S

NOTE: Materials listed are typical for stainless steel trim valves. Stronger materials may be used to satisfy design requirements.

Assemblies are illustrations only. Parts may vary according to design.

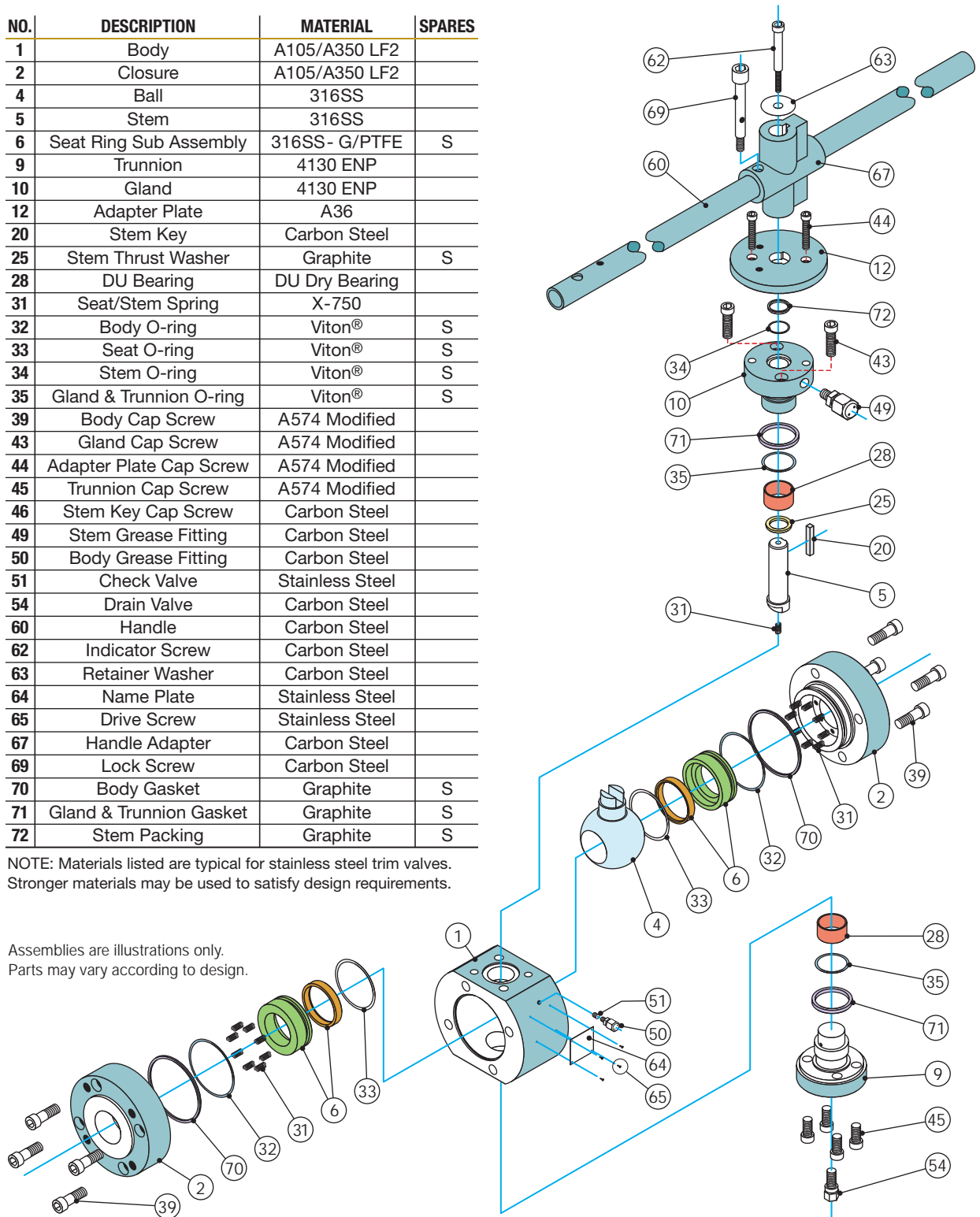

# DIMENSIONAL DATA FOR LOW PRESSURE SMALL SIZE DIAMETER VALVES ▶ ▶ ▶

Series 6700 • 2" - 4" Class 150 • 2" Class 300

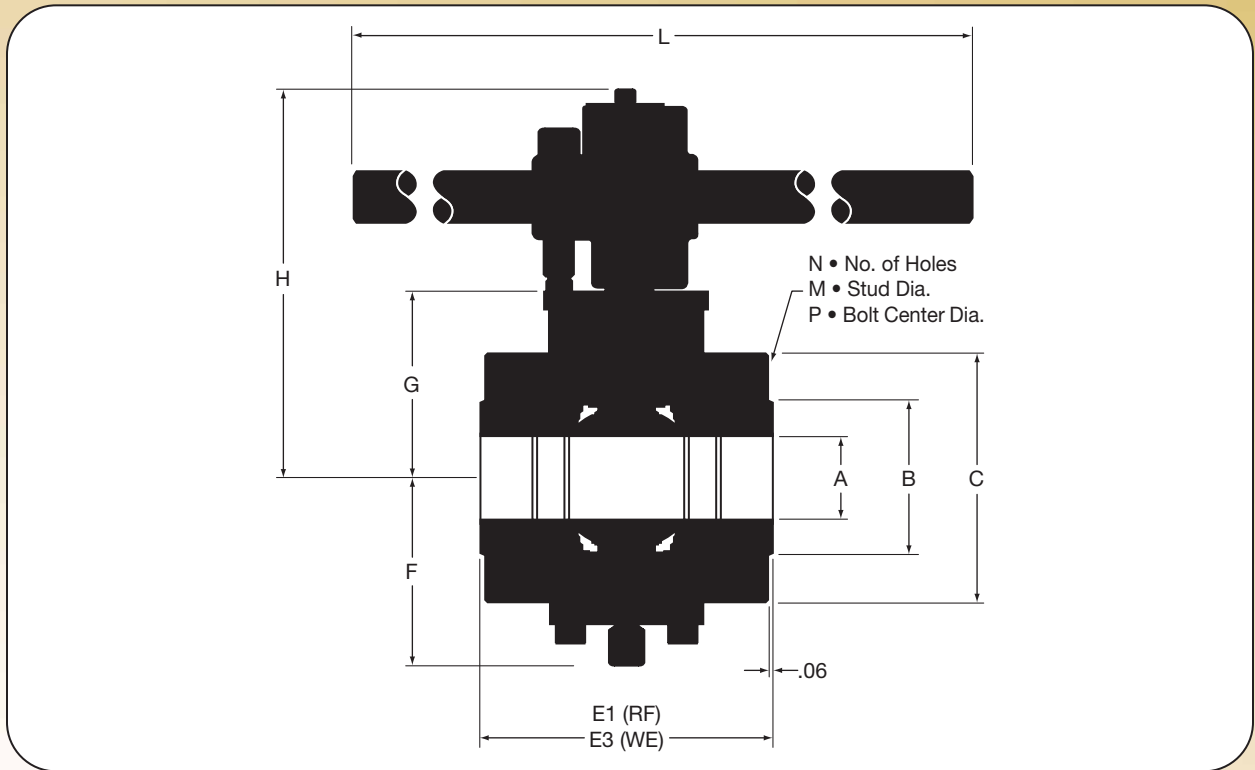

## Class 150 2" FP - 4" FP (in.)

SIZE	A	B	C	D1	E1-RF	E3-WE	F	G	H	N	M	P	L
2x2	2.00x2.00	3.62	6.00	NA	7.00	8.50	4.89	4.87	9.55	4	5/8-11UNC	4.75	30
3x3	3.00x3.00	5.00	7.87	NA	8.00	11.12	5.87	5.94	10.92	4	5/8-11UNC	6.00	30
4x4	4.00x4.00	6.19	9.49	NA	9.00	12.00	7.30	7.35	12.93	8	5/8-11UNC	7.50	48

## Class 300 2" FP (in.)

SIZE	A	B	C	D1	E1-RF	E3-WE	F	G	H	N	M	P	L
2x2	2.00x2.00	3.62	6.50	NA	8.50	8.50	4.89	4.87	9.55	8	5/8-11UNC	5.00	30

### SMALL BORE VALVE DESIGN UTILIZES TAPPED HOLES IN THE END FLANGES TO MAINTAIN API 6D FACE-TO-FACE SPECIFICATIONS

Small diameter trunnion ball valves often require tapped holes on the end flanges in order to maintain the face-to-face dimensions specified in API 6D. The full bore valves have tapped holes in accordance with API 6D instead of straight holes on both ends. The recommended stud length is listed at right.

### For Reference Only Stud Length to Install Valve

BORE SIZE	STUD BOLT SIZE	QUANTITY/FLANGE
2-150	5/8-11UNC X 2.25	4
3-150	5/8-11UNC X 2.38	4
4-150	5/8-11UNC X 2.50	8
2-300	5/8-11UNC X 2.50	8



# PARTS FOR HIGH PRESSURE SMALL SIZE DIAMETER VALVES ▶▶▶

Series 5700/6700 • 3"FP - 4"RP Class 300 • 2" - 4" Class 600, 900, 1500 and 2500

NO.	DESCRIPTION	MATERIAL	SPARES
1	Body	A105/A350 LF2	
2	Closure/Flanged End	A105/A350 LF2	
4	Ball	316SS	
5	Stem	316SS	
6	Seat Ring Sub Assembly	316SS- G/PTFE 316SS- Nylon	S
9	Trunnion	4130 ENP	
10	Gland	4130 ENP	
12	Adapter Plate	A36	
20	Stem Key	Carbon Steel	
25	Stem Thrust Washer	Graphite	S
28	DU Bearing	DU Dry Bearing	
31	Seat/Stem Spring	X-750	
32	Body O-ring	Viton®	S
33	Seat O-ring	Viton®	S
34	Stem O-ring	Viton®	S
35	Gland & Trunnion O-ring	Viton®	S
39	Body Stud	A193 B7M	
40	Body Nut	A194 2HM	
43	Gland Cap Screw	A574 Modified	
44	Adapter Plate Cap Screw	A574 Modified	
45	Trunnion Cap Screw	A574 Modified	
46	Stem Key Cap Screw	Carbon Steel	
49	Stem Grease Fitting	Carbon Steel	
50	Body Grease Fitting	Carbon Steel	
51	Check Valve	Stainless Steel	
54	Drain Valve	Carbon Steel	
60	Handle	Carbon Steel	
62	Indicator Screw	Carbon Steel	
63	Retainer Washer	Carbon Steel	
64	Name Plate	Stainless Steel	
65	Drive Screw	Stainless Steel	
67	Handle Adapter	Carbon Steel	
69	Lock Screw	Carbon Steel	
70	Body Gasket	Graphite	S
71	Gland & Trunnion Gasket	Graphite	S
72	Stem Packing	Graphite	S

NOTE: Materials listed are typical for stainless steel trim valves. Stronger materials may be used to satisfy design requirements.

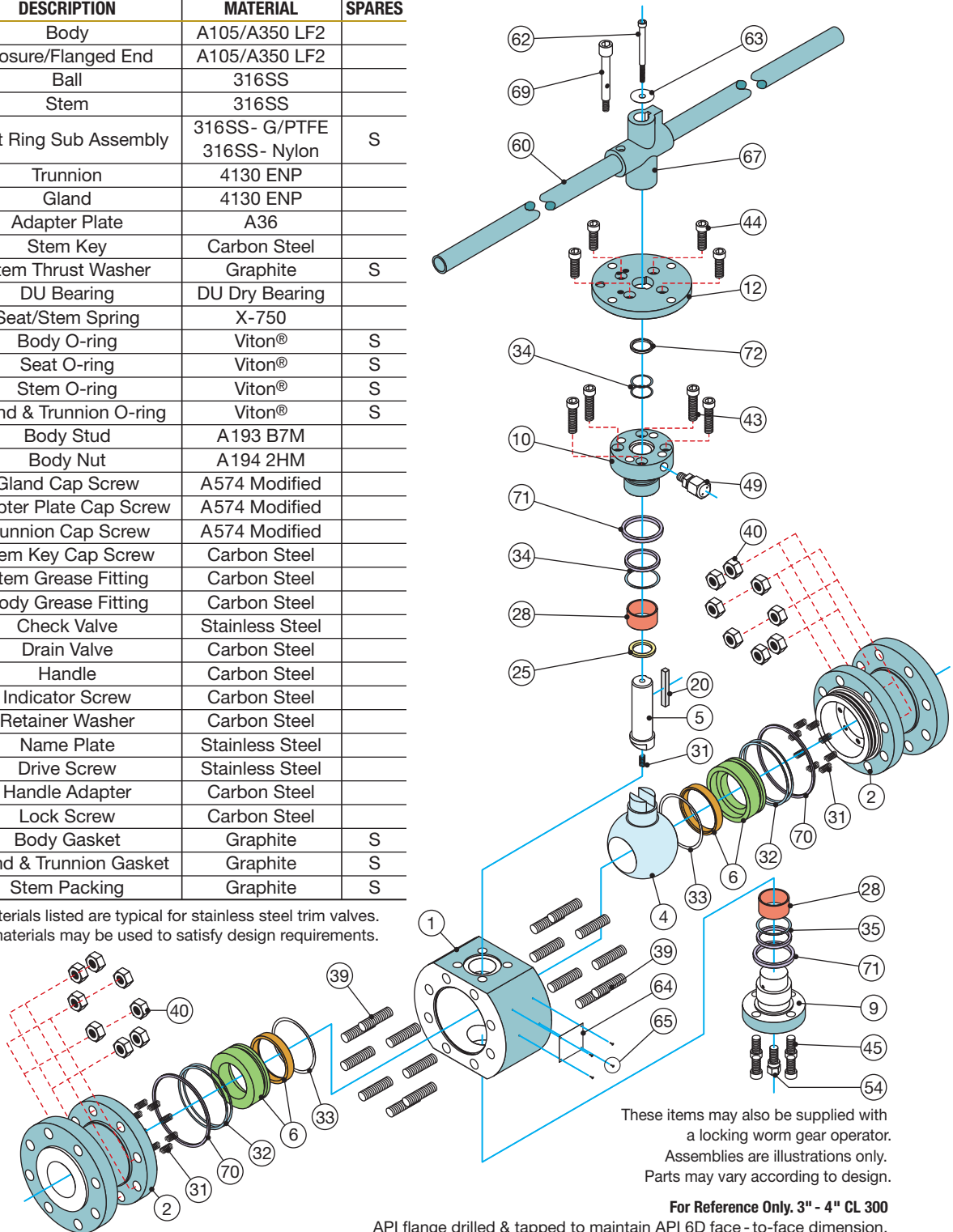

These items may also be supplied with a locking worm gear operator. Assemblies are illustrations only. Parts may vary according to design.

**For Reference Only. 3" - 4" CL 300**

API flange drilled & tapped to maintain API 6D face-to-face dimension.

3" x 3" CL 300 • Use 3/4"-10UNC x 3.38" stud. 4" x 4" CL 300 • Use 3/4"-10UNC x 3.5" stud.





# DIMENSIONAL DATA FOR HIGH PRESSURE SMALL SIZE DIAMETER VALVES ▶ ▶ ▶

Series 5700/6700 • 6"RP Class 150 • 3"RP - 6"RP Class 300 • 2"FP - 6"RP Class 600

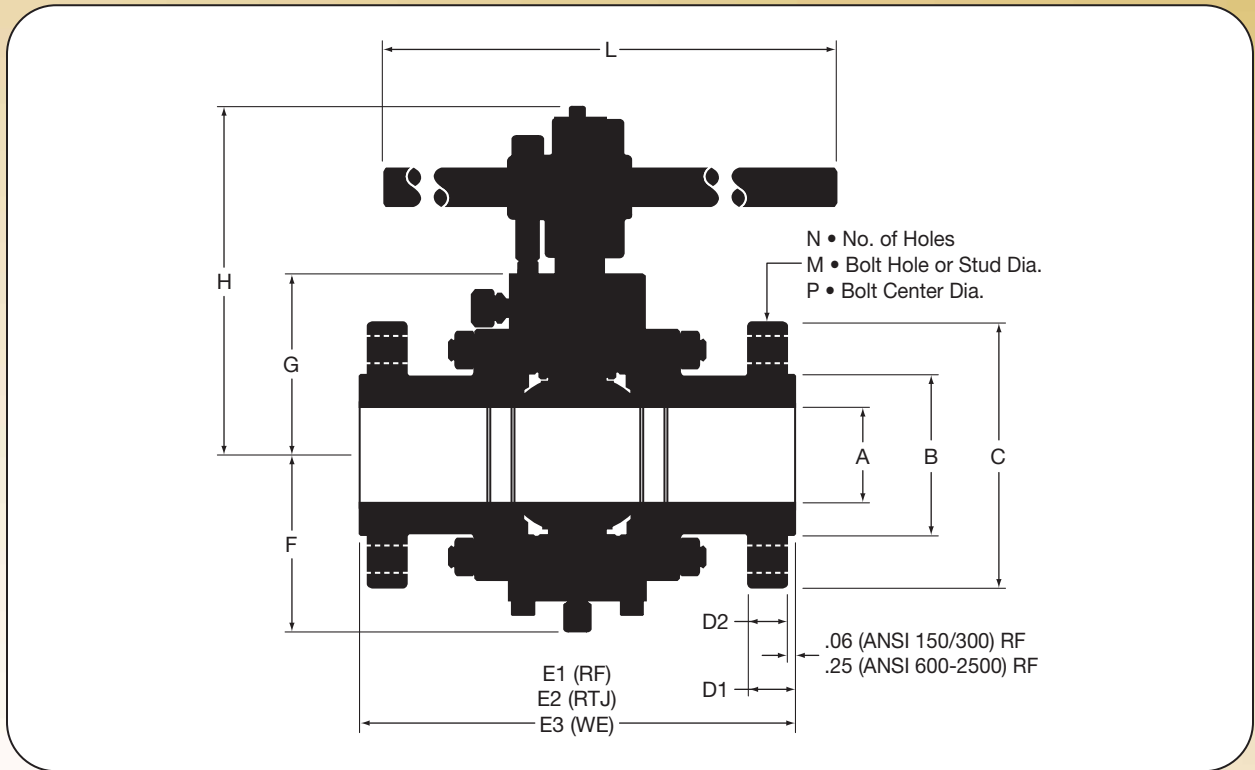

## Class 150 6"RP (in.)

SIZE	A	B	C	D1	E1-RF	E2-RTJ	E3-WE	F	G	H	N	M	P	L
6x4	6.00x4.00	8.50	11.00	1.00	15.50	16.00	18.00	7.30	7.35	12.93	8	0.88	9.50	48

## Class 300 3"RP - 6"RP (in.)

SIZE	A	B	C	D1	E1-RF	E2-RTJ	E3-WE	F	G	H	N	M	P	L
3x2	3.00x2.00	5.00	8.25	1.12	11.12	11.75	11.12	4.89	4.87	9.55	8	0.88	6.62	30
3x3	3.00x3.00	5.00	8.25	1.12	11.12	11.75	11.12	5.87	5.94	10.92	8	3/4-10UNC	6.62	30
4x3	4.00x3.00	6.19	10.00	1.25	12.00	12.62	12.00	5.87	5.94	10.92	8	0.88	7.88	30
4x4	4.00x4.00	6.19	10.00	1.25	12.00	12.62	12.00	7.30	7.35	12.93	8	3/4-10UNC	7.88	48
6x4	6.00x4.00	8.50	12.50	1.44	15.88	16.50	18.00	7.30	7.35	12.93	12	0.88	10.62	48

## Class 600 2"FP - 6"RP (in.)

SIZE	A	B	C	D1	E1-RF	E2-RTJ	E3-WE	F	G	H	N	M	P	L
2x2	2.00x2.00	3.62	6.50	1.00	11.50	11.62	11.50	4.89	4.87	9.55	8	0.75	5.00	30
3x2	3.00x2.00	5.00	8.25	1.25	14.00	14.12	14.00	4.89	4.87	9.55	8	0.88	6.62	30
3x3	3.00x3.00	5.00	8.25	1.25	14.00	14.12	14.00	5.87	5.94	10.92	8	0.88	6.62	30
4x3	4.00x3.00	6.19	10.75	1.50	17.00	17.12	17.00	5.87	5.94	10.92	8	1.00	8.50	30
4x4	4.00x4.00	6.19	10.75	1.50	17.00	17.12	17.00	7.30	7.35	12.93	8	1.00	8.50	48
6x4	6.00x4.00	8.50	14.00	1.88	22.00	22.12	22.00	7.30	7.35	12.93	12	1.12	11.50	48



# DIMENSIONAL DATA FOR HIGH PRESSURE SMALL SIZE DIAMETER VALVES ▶ ▶ ▶

Series 5700/6700 • 2"FP- 6"RP Class 900, 1500 and 2500

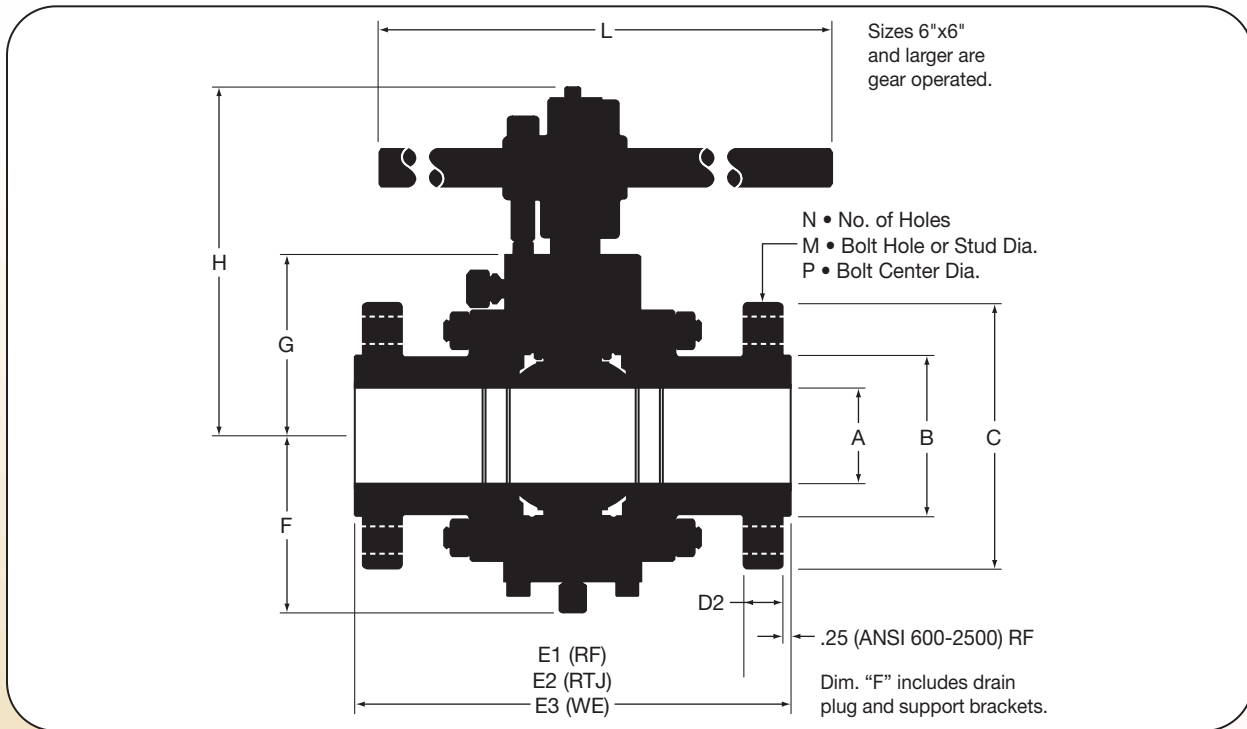

## Class 900 2" FP - 6" RP (in.)

SIZE	A	B	C	D2	E1-RF	E2-RTJ	E3-WE	F	G	H	N	M	P	L
2x2	2.00x2.00	3.62	8.50	1.50	14.50	14.62	14.50	4.89	4.87	9.55	8	1.00	6.50	30
3x2	3.00x2.00	5.00	9.50	1.50	15.00	15.12	15.00	4.89	4.87	9.55	8	1.00	7.50	30
3x3	3.00x3.00	5.00	9.50	1.50	15.00	15.12	15.00	5.87	5.94	10.92	8	1.00	7.50	30
4x3	4.00x3.00	6.19	11.50	1.75	18.00	18.12	18.00	5.87	5.94	10.92	8	1.25	9.25	30
4x4	4.00x4.00	6.19	11.50	1.75	18.00	18.12	18.00	7.30	7.35	12.93	8	1.25	9.25	48
6x4	6.00x4.00	8.50	15.00	2.19	24.00	24.12	24.00	7.30	7.35	12.93	12	1.25	12.50	48

## Class 1500 2" FP - 6" RP (in.)

SIZE	A	B	C	D2	E1-RF	E2-RTJ	E3-WE	F	G	H	N	M	P	L
2x2	2.00x2.00	3.62	8.50	1.50	14.50	14.62	14.50	5.32	5.47	10.30	8	1.00	6.50	30
3x2	3.00x2.00	5.00	10.50	1.88	18.50	18.62	18.50	5.32	5.47	10.30	8	1.25	8.00	30
3x3	3.00x3.00	5.00	10.50	1.88	18.50	18.62	18.50	6.89	6.42	11.60	8	1.25	8.00	30
4x3	4.00x3.00	6.19	12.25	2.12	21.50	21.62	21.50	6.89	6.42	11.60	8	1.38	9.50	30
4x4	4.00x4.00	6.19	12.25	2.12	21.50	21.62	21.50	8.14	7.88	13.75	8	1.38	9.50	48
6x4	5.75x4.00	8.50	15.50	3.25	27.75	28.00	27.75	8.14	7.88	13.75	12	1.50	12.50	48

## Class 2500 2" FP - 6" RP (in.)

SIZE	A	B	C	D2	E1-RF	E2-RTJ	E3-WE	F	G	H	N	M	P	L
2x2	1.75x1.75	3.62	9.25	2.00	17.75	17.87	17.75	6.39	7.25	13.19	8	1.12	6.75	30
3x2	2.50x1.75	5.00	12.00	2.62	22.75	23.00	22.75	6.39	7.25	13.19	8	1.38	9.00	30
3x3	2.50x2.50	5.00	12.00	2.62	22.75	23.00	22.75	8.20	8.42	14.68	8	1.38	9.00	30
4x3	3.50x2.50	6.19	14.00	3.00	26.50	26.88	26.50	8.20	8.42	14.68	8	1.63	10.75	30
4x4	3.50x3.50	6.19	14.00	3.00	26.50	26.88	26.50	9.43	10.56	16.93	8	1.63	10.75	48
6x4	5.25x3.50	8.50	19.00	4.25	36.00	36.50	36.00	9.43	10.56	16.93	8	2.12	14.50	48



# PARTS FOR MID SIZE DIAMETER VALVES ▶▶▶

Series 5700 • 8" - 14"RP Class 150, 300, 600, 900 and 1500 • 6" - 12"RP Class 2500

Series 6700 • 6" - 12"FP Class 150, 300, 600, 900 and 1500 • 6" - 10"FP Class 2500

NO.	DESCRIPTION	MATERIAL	SPARES
1	Body	A105/A350 LF2	
2	Closure/Flanged End	A105/A350 LF2	
4	Ball	A105/A350 LF2 ENP	
5	Stem	4130 ENP	
6	Seat Ring Sub Assembly	A105/A350 LF2 ENP G/PTFE or Nylon	S
9	Trunnion	4130 ENP	
10	Gland	4130 ENP	
11	Bushing	Carbon Steel	
12	Adapter Plate	A36	
18	Gland Pin	Carbon Steel	
20	Stem Key	Carbon Steel	
25	Stem Thrust Washer	Graphite	S
28	DU Bearing	DU Dry Bearing	
31	Seat Spring	X-750	
32	Body O-ring	Viton®	S
33	Seat O-ring	Viton®	S
34	Stem O-ring	Viton®	S
35	Gland & Trunnion O-ring	Viton®	S
36	Emerg. Sealant O-ring	Viton®	S
39	Body Stud	A193 B7M	
40	Body Nut	A194 2HM	
43	Gland Cap Screw	A574 Modified	
44	Adapter Plate Cap Screw	A574 Modified	
45	Trunnion Cap Screw	A574 Modified	
46	Stem Key Cap Screw	Carbon Steel	
47	Gear Stud	A193 B7	
48	Gear/Adapter Plate Nut	A194 2H	
49	Stem Grease Fitting	Carbon Steel	
50	Seat Grease Fitting	Carbon Steel	
51	Check Valve	Stainless Steel	
52	Vent Plug	Carbon Steel	
53	Lifting Lug Stud	A193 B7M	
54	Drain Valve	Carbon Steel	
55	Lifting Lug	Carbon Steel	
57	Worm Gear Operator	Commercial	
60	Handwheel	Carbon Steel	
64	Name Plate	Stainless Steel	
65	Drive Screw	Stainless Steel	
70	Body Gasket	Graphite	S
71	Gland & Trunnion Gasket	Graphite	S
72	Stem Packing	Graphite	S

Sizes 6" and 8" may be supplied with locking levers.  
 Sizes 10" and 12" are supplied with support feet, not shown.  
 Materials listed are typical for carbon steel valves.  
 Ball, stem & seat rings will be 316, 17-4PH, or XM-19 for stainless steel trim depending on design requirements.

Assemblies are illustrations only.  
 Parts may vary according to design.

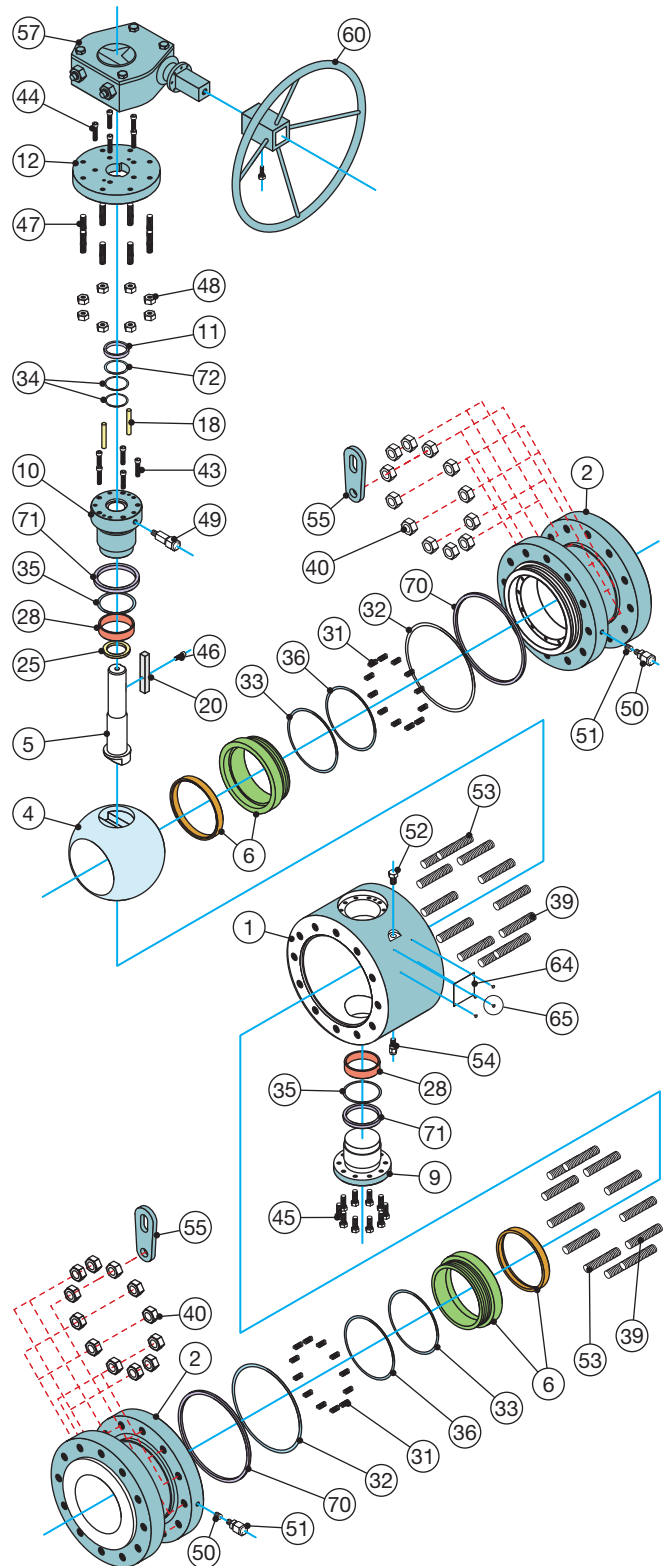

# DIMENSIONAL DATA FOR MID SIZE DIAMETER VALVES ▶ ▶ ▶

Series 5700/6700 • 6"FP - 14"RP • Class 150, 300 and 600

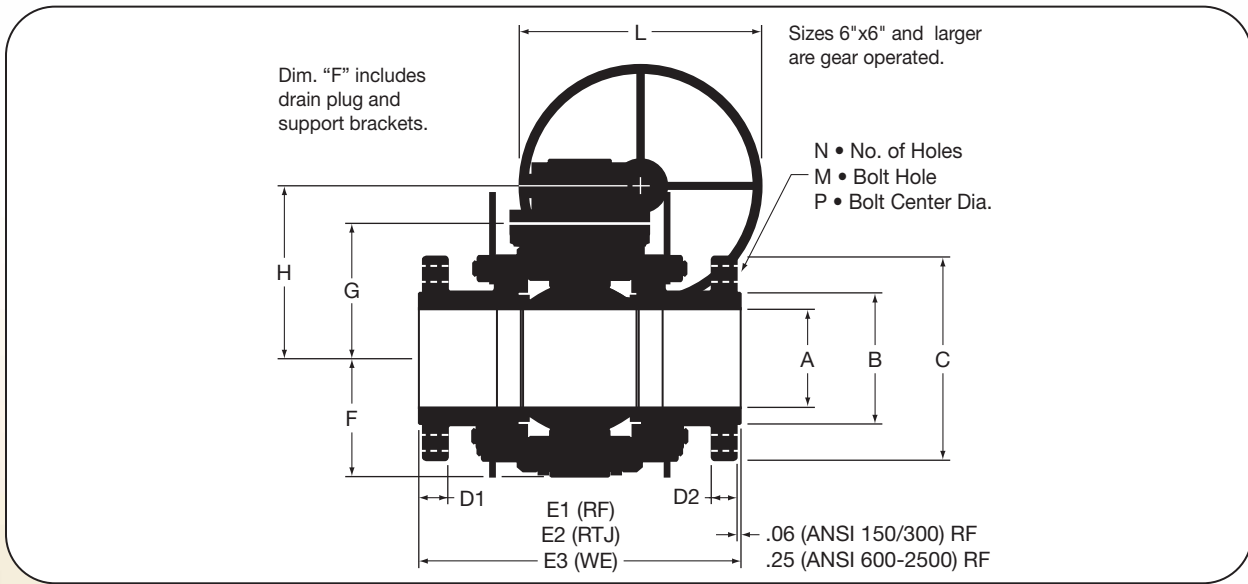

## Class 150 6"FP - 14"RP (in.)

SIZE	A	B	C	D1	E1-RF	E2-RTJ	E3-WE	F	G	H	N	M	P	L
6x6	6.00x6.00	8.50	11.00	1.00	15.50	16.00	18.00	7.25	8.48	10.63	8	0.88	9.50	24
8x6	8.00x6.00	10.62	13.50	1.12	18.00	18.50	20.50	7.25	8.48	10.63	8	0.88	11.75	24
8x8	8.00x8.00	10.62	13.50	1.12	18.00	18.50	20.50	8.72	10.13	12.26	8	0.88	11.75	24
10x8	10.00x8.00	12.75	16.00	1.19	21.00	21.50	22.00	8.72	10.13	12.26	12	1.00	14.25	24
10x10	10.00x10.00	12.75	16.00	1.19	21.00	21.50	22.00	10.56	11.96	14.09	12	1.00	14.25	24
12x10	12.00x10.00	15.00	19.00	1.25	24.00	24.50	25.00	10.56	11.96	14.09	12	1.00	17.00	24
12x12	12.00x12.00	15.00	19.00	1.25	24.00	24.50	25.00	12.26	13.75	15.88	12	1.00	17.00	24
14x12	13.25x12.00	16.25	21.00	1.38	27.00	27.50	30.00	12.26	13.75	15.88	12	1.12	18.75	24

## Class 300 6"FP - 14"RP (in.)

SIZE	A	B	C	D1	E1-RF	E2-RTJ	E3-WE	F	G	H	N	M	P	L
6x6	6.00x6.00	8.50	12.50	1.44	15.88	16.50	18.00	7.25	8.48	10.63	12	0.88	10.62	24
8x6	8.00x6.00	10.62	15.00	1.62	19.75	20.38	20.50	7.25	8.48	10.63	12	1.00	13.00	24
8x8	8.00x8.00	10.62	15.00	1.62	19.75	20.38	20.50	8.72	10.13	12.26	12	1.00	13.00	24
10x8	10.00x8.00	12.75	17.50	1.88	22.38	23.00	22.00	8.72	10.13	12.26	16	1.12	15.25	24
10x10	10.00x10.00	12.75	17.50	1.88	22.38	23.00	22.00	10.56	11.96	14.09	16	1.12	15.25	24
12x10	12.00x10.00	15.00	20.50	2.00	25.50	26.12	25.00	10.56	11.96	14.09	16	1.25	17.75	24
12x12	12.00x12.00	15.00	20.50	2.00	25.50	26.12	25.00	12.26	13.75	15.88	16	1.25	17.75	24
14x12	13.25x12.00	16.25	23.00	2.12	30.00	30.62	30.00	12.26	13.75	15.88	20	1.25	20.25	30

## Class 600 6"FP - 14"RP (in.)

SIZE	A	B	C	D2	E1-RF	E2-RTJ	E3-WE	F	G	H	N	M	P	L
6x6	6.00x6.00	8.50	14.00	1.88	22.00	22.12	22.00	7.25	8.48	10.63	12	1.12	11.50	24
8x6	8.00x6.00	10.62	16.50	2.19	26.00	26.12	26.00	7.25	8.48	10.63	12	1.25	13.75	24
8x8	8.00x8.00	10.62	16.50	2.19	26.00	26.12	26.00	10.00	11.57	13.70	12	1.25	13.75	24
10x8	10.00x8.00	12.75	20.00	2.50	31.00	31.12	31.00	10.00	11.57	13.70	16	1.38	17.00	24
10x10	10.00x10.00	12.75	20.00	2.50	31.00	31.12	31.00	11.74	13.32	15.45	16	1.38	17.00	24
12x10	12.00x12.00	15.00	22.00	2.62	33.00	33.12	33.00	11.74	13.32	15.45	20	1.38	19.25	24
12x12	12.00x12.00	15.00	22.00	2.62	33.00	33.12	33.00	13.86	14.94	21.52	20	1.38	19.25	30
14x12	13.25x12.00	16.25	23.75	2.75	35.00	35.12	35.00	13.86	14.94	21.52	20	1.50	20.75	30



# DIMENSIONAL DATA FOR MID SIZE DIAMETER VALVES ▶ ▶ ▶

## Series 5700/6700 • 6"FP - 14"RP • Class 900 and 1500

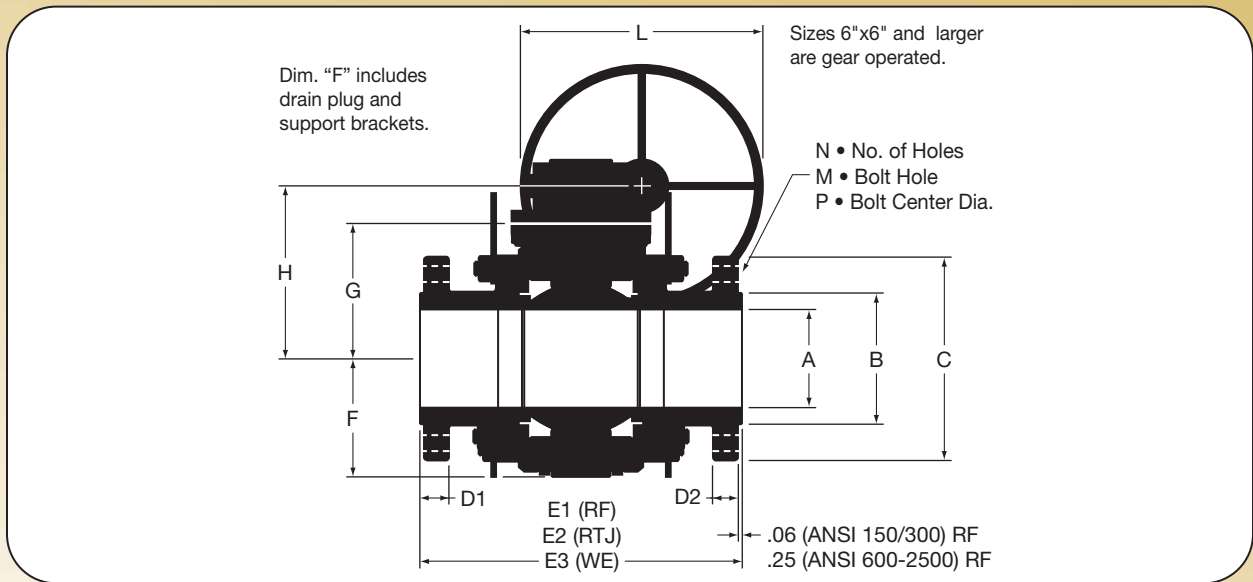

### Class 900 6"FP - 14"RP (in.)

SIZE	A	B	C	D2	E1-RF	E2-RTJ	E3-WE	F	G	H	N	M	P	L
6x6	6.00x6.00	8.50	15.00	2.19	24.00	24.12	24.00	8.62	10.01	12.14	12	1.25	12.50	24
8x6	8.00x6.00	10.62	18.50	2.50	29.00	29.12	29.00	8.62	10.01	12.14	12	1.50	15.50	24
8x8	8.00x8.00	10.62	18.50	2.50	29.00	29.12	29.00	10.00	11.57	13.70	12	1.50	15.50	24
10x8	10.00x8.00	12.75	21.50	2.75	33.00	33.12	33.00	10.00	11.57	13.70	16	1.50	18.50	24
10x10	10.00x10.00	12.75	21.50	2.75	33.00	33.12	33.00	11.74	13.32	19.90	16	1.50	18.50	30
12x10	12.00x12.00	15.00	24.00	3.12	38.00	38.12	38.00	11.74	13.32	19.90	20	1.50	21.00	30
12x12	12.00x12.00	15.00	24.00	3.12	38.00	38.12	38.00	13.86	14.94	21.52	20	1.50	21.00	30
14x12	12.75x12.00	16.25	25.25	3.38	40.50	40.88	40.50	13.86	14.94	21.52	20	1.62	22.00	30

### Class 1500 6"FP - 14"RP (in.)

SIZE	A	B	C	D2	E1-RF	E2-RTJ	E3-WE	F	G	H	N	M	P	L
6x6	5.75x5.75	8.50	15.50	3.25	27.75	28.00	27.75	9.72	10.67	12.80	12	1.50	12.50	24
8x6	7.63x5.75	10.62	19.00	3.62	32.75	33.13	32.75	9.72	10.67	12.80	12	1.75	15.50	24
8x8	7.63x7.63	10.62	19.00	3.62	32.75	33.13	32.75	12.16	12.88	19.46	12	1.75	15.50	30
10x8	9.50x7.63	12.75	23.00	4.25	39.00	39.38	39.00	12.16	12.88	19.46	12	2.00	19.00	30
10x10	9.50x9.50	12.75	23.00	4.25	39.00	39.38	39.00	14.40	15.48	22.06	12	2.00	19.00	30
12x10	11.38x9.50	15.00	26.50	4.88	44.50	45.12	44.50	14.40	15.48	22.06	16	2.12	22.50	30
12x12	11.38x11.38	15.00	26.50	4.88	44.50	45.12	44.50	16.98	17.83	24.41	16	2.12	22.50	30
14x12	12.50x11.38	16.25	29.50	5.25	49.50	50.25	49.50	16.98	17.83	24.41	16	2.38	25.00	30

### Class 2500 6"FP - 12"RP (in.)

SIZE	A	B	C	D2	E1-RF	E2-RTJ	E3-WE	F	G	H	N	M	P	L
6x6	5.25x5.25	8.50	19.00	4.25	36.00	36.50	36.00	12.74	12.70	19.28	8	2.12	14.50	30
8x6	7.14x5.25	10.62	21.75	5.00	40.25	40.87	40.25	12.74	12.70	19.28	12	2.12	17.25	30
8x8	7.14 x 7.14	10.62	21.75	5.00	40.25	40.87	40.25	15.22	16.63	18.76	12	2.12	17.25	30
10x8	8.88x7.14	12.75	26.50	6.50	50.00	50.88	50.00	15.22	16.63	18.76	12	2.62	21.25	30
10x10	8.88x8.88	12.75	26.50	6.50	50.00	50.88	50.00	19.73	18.25	24.83	12	2.62	21.25	30
12x10	10.50x8.88	15.00	30.00	7.25	56.00	56.88	56.00	19.73	18.25	24.83	12	2.88	24.38	30
12x12	10.50x10.50	15.00	30.00	7.25	56.00	56.88	56.00	22.06	20.79	27.69	12	2.88	24.38	30

# PARTS FOR LARGE SIZE DIAMETER VALVES ▶▶▶

Series 5700/6700 • 14"FP - 56"FP Class 150, 300, 600, 900 and 1500 • 12" Class 2500

NO.	DESCRIPTION	MATERIAL	SPARES
1	Body	A105/A350 LF2	
2	Closure/Flanged End	A105/A350 LF2	
4	Ball	A105/A350 LF2 ENP	
5	Stem	4130 ENP	
6	Seat Ring Sub Assembly	A105/A350 LF2 ENP G/PTFE or Nylon	S
9	Bearing Retainer	Carbon Steel	
10	Gland	4130 ENP	
11	Bushing	Carbon Steel	
12	Adapter Plate	A36	
18	Gland Pin	Carbon Steel	
20	Stem Key	Carbon Steel	
22	Ball Thrust Washer	Phenolic	S
25	Stem Thrust Washer	Phenolic	S
28	DU Bearing	DU Dry Bearing	
31	Seat Spring	X-750	
32	Body O-ring	Viton®	S
33	Seat O-ring	Viton®	S
34	Stem O-ring	Viton®	S
35	Gland O-ring	Viton®	S
36	Emerg. Sealant O-ring	Viton®	S
38	Location Stud	A193 B7M	
39	Body Stud	A193 B7M	
40	Body Nut	A194 2HM	
43	Gland Cap Screw	A574 Modified	
44	Adapter Plate Cap Screw	A574 Modified	
46	Stem Key Cap Screw	Carbon Steel	
47	Gear Stud	A193 B7	
48	Gear/Adapter Plate Nut	A194 2H	
49	Stem Grease Fitting	Carbon Steel	
50	Seat Grease Fitting	Carbon Steel	
51	Check Valve	Stainless Steel	
52	Vent Plug	Carbon Steel	
53	Lifting Lug Stud	A193 B7M	
54	Drain Valve	Carbon Steel	
55	Lifting Lug	Carbon Steel	
56	Support Leg	Carbon Steel	
57	Worm Gear Operator	Commercial	
60	Handwheel	Carbon Steel	
64	Name Plate	Stainless Steel	
65	Drive Screw	Stainless Steel	
70	Body Gasket	Graphite	S
71	Gland & Trunnion Gasket	Graphite	S
72	Stem Packing	Graphite	S

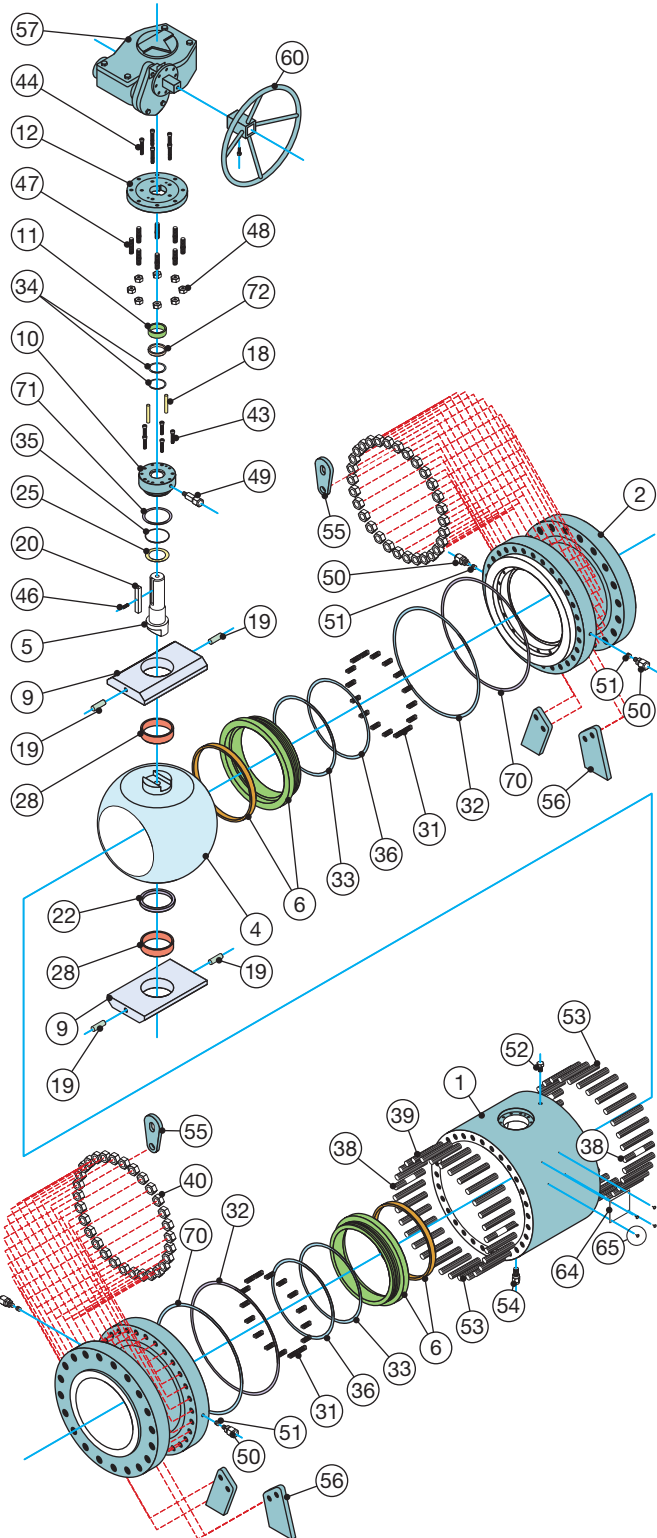

Materials listed are typical for carbon steel valves.  
Ball, stem & seat rings will be 316, 17-4PH, or XM-19  
for stainless steel trim depending on design requirements.

Assemblies are illustrations only.  
Parts may vary according to design.



# DIMENSIONAL DATA FOR LARGE SIZE DIAMETER VALVES ▶▶▶

Series 5700/6700 • 14"FP - 56"FP • Class 150

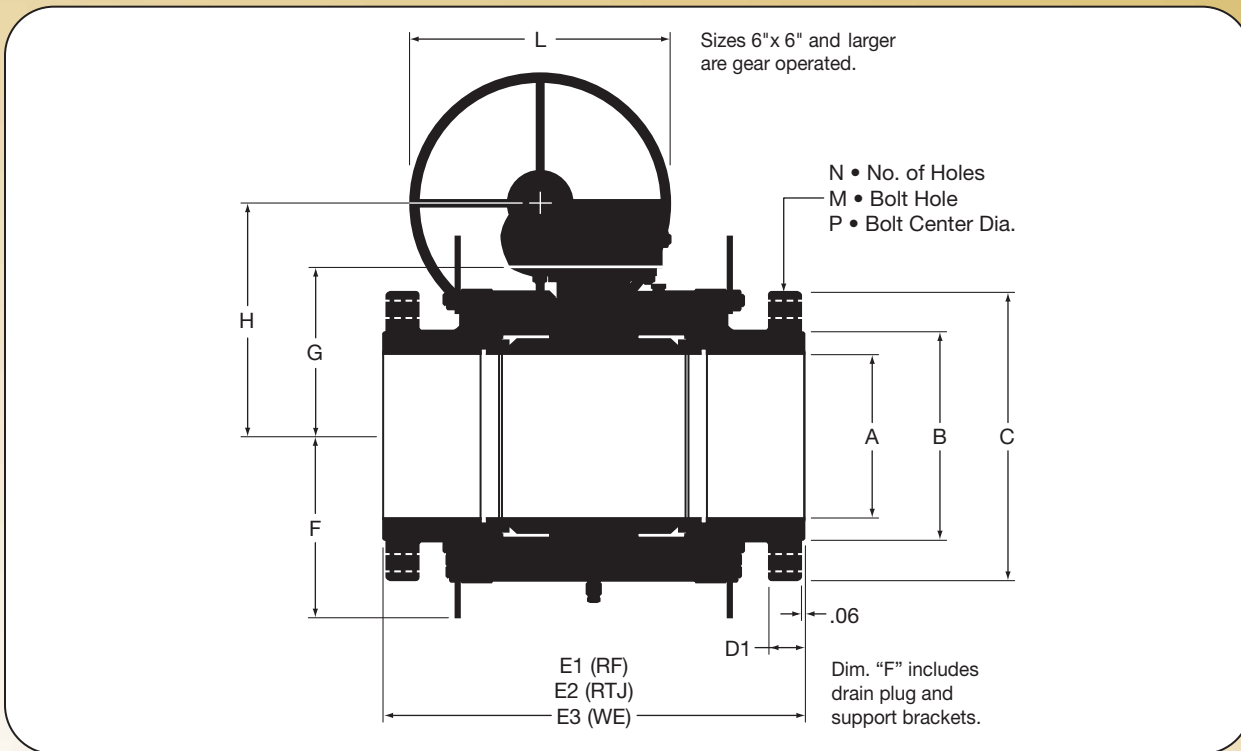

## Class 150 14"FP - 56"FP (in.)

SIZE	A	B	C	D1	E1-RF	E2-RTJ	E3-WE	F	G	H	N	M	P	L
14x14	13.25x13.25	16.25	21.00	1.38	27.00	27.50	30.00	14.92	15.18**	20.89	12	1.12	18.75	30
16x14	15.25x13.25	18.50	23.50	1.44	30.00	30.50	33.00	16.60	15.18**	20.89	16	1.12	21.25	30
16x16	15.25x15.25	18.50	23.50	1.44	30.00	30.50	33.00	16.60	15.89	22.47	16	1.12	21.25	30
18x16	17.25x15.25	21.00	25.00	1.56	34.00	34.50	36.00	21.05	15.89	22.47	16	1.25	22.75	30
18x18	17.25x17.25	21.00	25.00	1.56	34.00	34.50	36.00	21.05	19.76	26.34	16	1.25	22.75	30
20x18	19.25x17.25	23.00	27.50	1.69	36.00	36.50	39.00	19.67	19.76	26.34	20	1.25	25.00	30
20x20	19.25x19.25	23.00	27.50	1.69	36.00	36.50	39.00	19.67	20.20	26.78	20	1.25	25.00	30
24x20	23.25x19.25	27.25	32.00	1.88	42.00	42.50	45.00	22.75	20.20	26.78	20	1.38	29.50	30
24x24	23.25x23.25	27.25	32.00	1.88	42.00	42.50	45.00	22.75	23.34	30.24	20	1.38	29.50	30
30x30	29.00x29.00	33.75	38.75	2.88	51.00	*	55.00	31.25	32.08	38.98	28	1.38	36.00	30
36x36	34.50x34.50	40.25	46.00	3.50	60.00	*	68.00	34.39	35.83	42.73	32	1.62	42.75	30
40x40	38.50x38.50	44.25	50.75	3.50	72.83	*	70.08	36.54	37.13	*	*	*	*	*
44x44	42.32x42.32	49.00	55.25	3.94	76.77	*	74.80	39.76	40.39	*	*	*	*	*
48x48	45.98x45.98	53.50	59.50	4.19	85.83	*	82.68	41.77	43.19	*	*	*	*	*
56x56	53.62x53.62	62.00	68.75	4.82	90.55	*	88.58	48.50	49.92	*	*	*	*	*

\* Contact your PBV® salesperson for additional sizes and materials.

\*\* Change introduced 2004.



# DIMENSIONAL DATA FOR LARGE SIZE DIAMETER VALVES ▶▶▶

Series 5700/6700 • 14"FP - 56"FP • Class 300

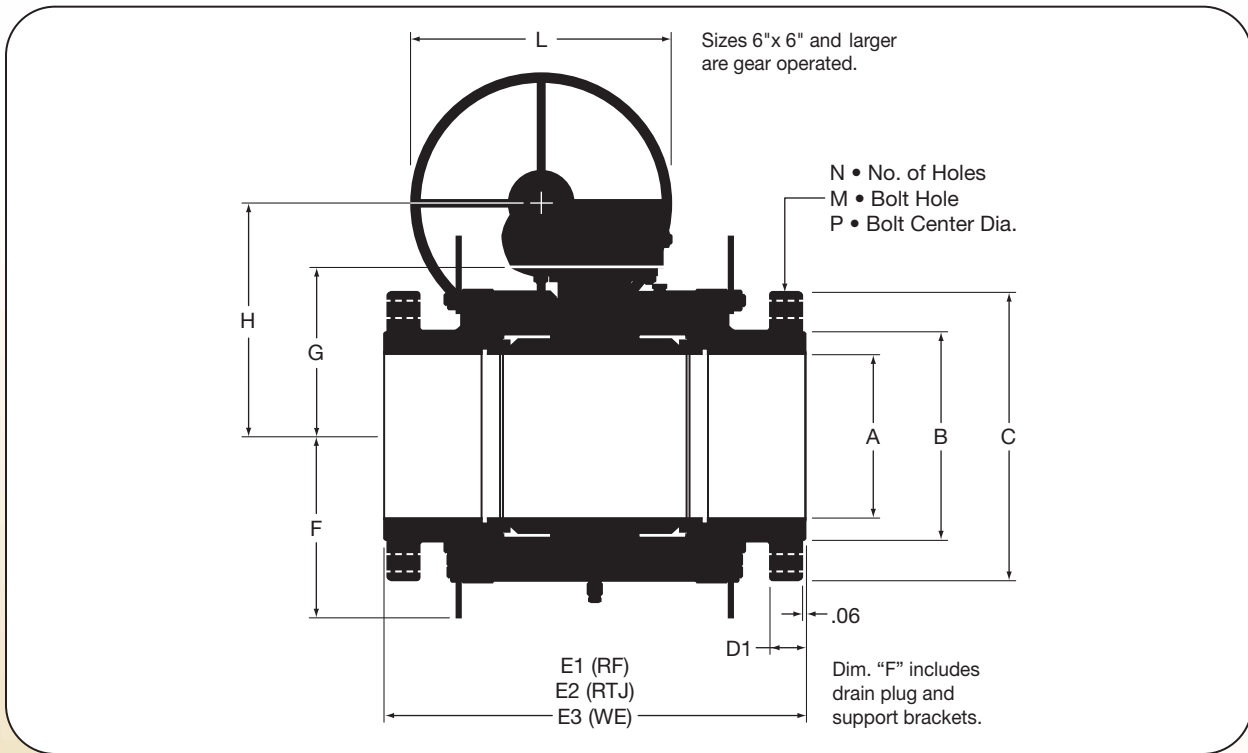

## Class 300 14"FP - 56"FP (in.)

SIZE	A	B	C	D1	E1-RF	E2-RTJ	E3-WE	F	G	H	N	M	P	L
14x14	13.25x13.25	16.25	23.00	2.12	30.00	30.62	30.00	14.92	14.31	20.89	20	1.25	20.25	30
16x14	15.25x13.25	18.50	25.50	2.25	33.00	33.62	33.00	16.60	14.31	20.89	20	1.38	22.50	30
16x16	15.25x15.25	18.50	25.50	2.25	33.00	33.62	33.00	16.60	15.89	22.47	20	1.38	22.50	30
18x16	17.25x15.25	21.00	28.00	2.38	36.00	36.62	36.00	21.05	15.89	22.47	24	1.38	24.75	30
18x18	17.25x17.25	21.00	28.00	2.38	36.00	36.62	36.00	21.05	19.76	26.34	24	1.38	24.75	30
20x18	19.25x17.25	23.00	30.50	2.50	39.00	39.75	39.00	19.67	19.76	26.34	24	1.38	27.00	30
20x20	19.25x19.25	23.00	30.50	2.50	39.00	39.75	39.00	19.67	20.20	26.78	24	1.38	27.00	30
24x20	23.25x19.25	27.25	36.00	2.75	45.00	45.88	45.00	22.75	20.20	26.78	24	1.62	32.00	30
24x24	23.25x23.25	27.25	36.00	2.75	45.00	45.88	45.00	22.75	23.34	30.24	24	1.62	32.00	30
30x30	29.00x29.00	33.75	43.00	3.62	55.00	56.00	55.00	31.25	32.08	38.98	28	1.88	39.25	30
36x36	34.50x34.50	40.25	50.00	4.12	68.00	69.12	68.00	34.39	35.83	42.73	32	2.12	46.00	30
40x40	38.50x38.50	42.75	48.75	4.44	72.83	*	70.08	36.54	37.13	*	*	*	*	*
44x44	42.32x42.32	47.00	53.25	4.82	76.77	*	74.80	39.76	40.39	*	*	*	*	*
48x48	45.98x45.98	51.25	57.75	5.19	85.83	*	82.68	41.77	43.19	*	*	*	*	*
56x56	53.62x53.62	59.75	67.25	6.00	90.55	*	88.58	48.50	49.92	*	*	*	*	*

\* Contact your PBV® salesperson for additional sizes and materials.





# DIMENSIONAL DATA FOR LARGE SIZE DIAMETER VALVES ▶▶▶

Series 5700/6700 • 14"FP - 56"FP • Class 600

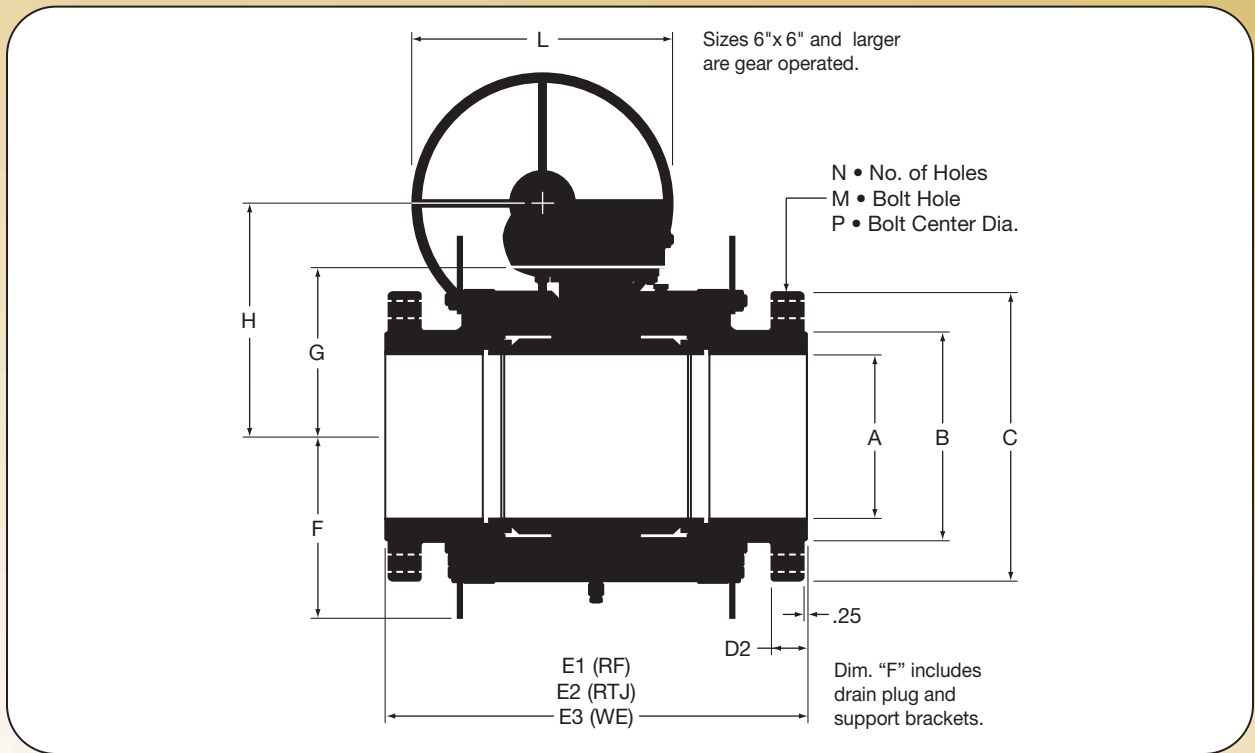

## Class 600 14"FP - 56"FP (in.)

SIZE	A	B	C	D2	E1-RF	E2-RTJ	E3-WE	F	G	H	N	M	P	L
14x14	13.25x13.25	16.25	23.75	2.75	35.00	35.12	35.00	14.92	14.31	20.89	20	1.50	20.75	30
16x14	15.25x13.25	18.50	27.00	3.00	39.00	39.12	39.00	16.33	14.31	20.89	20	1.62	23.75	30
16x16	15.25x15.25	18.50	27.00	3.00	39.00	39.12	39.00	16.33	15.89	22.47	20	1.62	23.75	30
18x16	17.25x15.25	21.00	29.25	3.25	43.00	43.12	43.00	21.05	15.89	22.47	20	1.75	25.75	30
18x18	17.25x17.25	21.00	29.25	3.25	43.00	43.12	43.00	21.05	19.76	23.20	20	1.75	25.75	30
20x18	19.25x17.25	23.00	32.00	3.50	47.00	47.25	47.00	19.67	19.76	23.20	24	1.75	28.50	30
20x20	19.25x19.25	23.00	32.00	3.50	47.00	47.25	47.00	19.67	20.09	23.53	24	1.75	28.50	30
24x20	23.25x19.25	27.25	37.00	4.00	55.00	55.38	55.00	23.13	20.09	23.53	24	2.00	33.00	30
24x24	23.25x23.25	27.25	37.00	4.00	55.00	55.38	55.00	23.13	25.35**	28.79	24	2.00	33.00	30
30x30	29.00x29.00	33.75	44.50	4.50	65.00	65.50	65.00	31.25	32.08	38.98	28	2.13	40.25	30
36x36	34.50x34.50	40.25	51.75	4.88	82.00	82.64	82.01	34.39	35.83	42.73	28	2.62	47.00	30
40x40	38.50x38.50	43.75	52.00	6.25	78.74	*	74.80	37.13	37.60	*	*	*	*	*
44x44	42.32x42.32	48.25	57.25	6.81	86.61	*	80.71	40.55	41.73	*	*	*	*	*
48x48	45.98x45.98	52.50	62.75	7.44	94.49	*	85.83	43.50	44.69	*	*	*	*	*
56x56	53.62x53.62	60.75	73.00	8.56	*	*	93.90	49.37	50.79	*	*	*	*	*

\* Contact your PBV® salesperson for additional sizes and materials.

\*\* Change introduced 2007



# DIMENSIONAL DATA FOR LARGE SIZE DIAMETER VALVES ▶ ▶ ▶

Series 5700/6700 • 14"FP - 48"FP Class 900 • 14"FP - 24"FP Class 1500

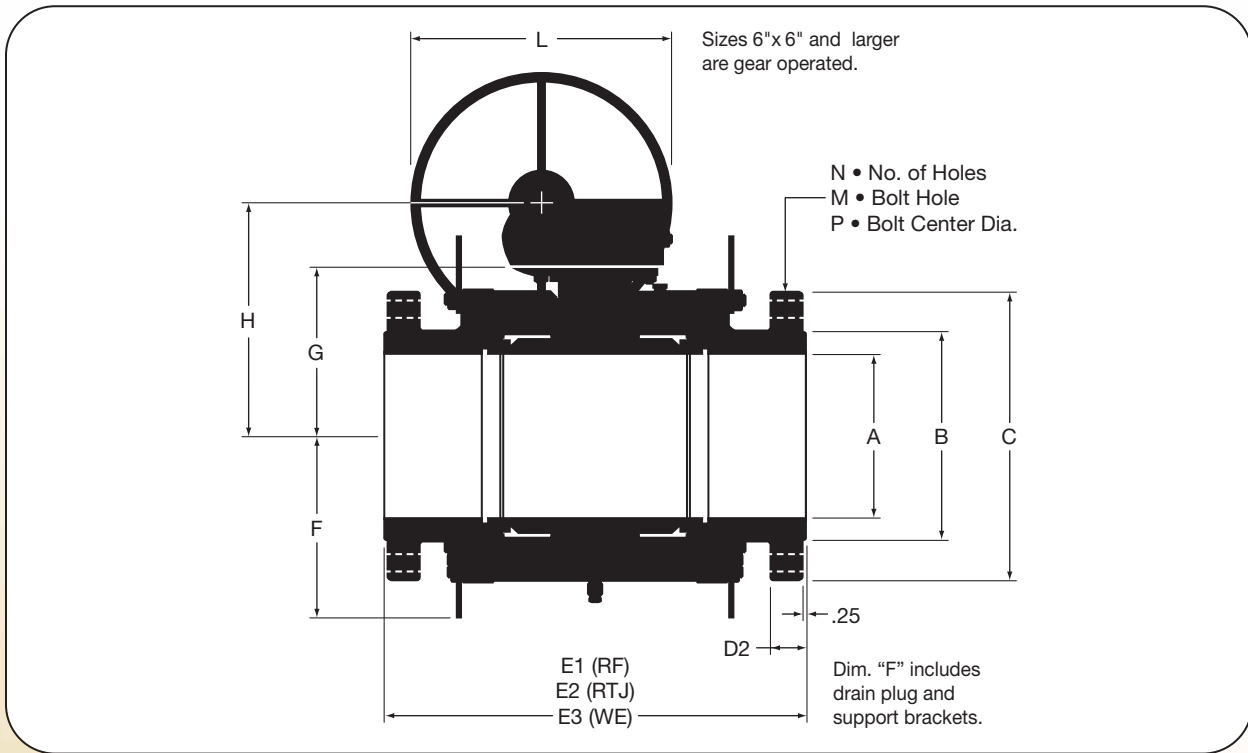

## Class 900 14"FP - 48"FP (in.)

SIZE	A	B	C	D2	E1-RF	E2-RTJ	E3-WE	F	G	H	N	M	P	L
14x14	12.75 x 12.75	16.25	25.25	3.38	40.50	40.88	40.50	18.61	16.76	23.34	20	1.62	22.00	30
16x14	14.75 x 12.75	18.50	27.75	3.50	44.50	44.88	44.50	20.63	16.76	23.34	20	1.75	24.25	30
16x16	14.75 x 14.75	18.50	27.75	3.50	44.50	44.88	44.50	20.63	18.87	25.77	20	1.75	24.25	30
18x16	16.75 x 14.75	21.00	31.00	4.00	48.00	48.50	48.00	23.39	18.87	25.77	20	2.00	27.00	30
18x18	16.75 x 16.75	21.00	31.00	4.00	48.00	48.50	48.00	23.39	24.91	31.81	20	2.00	27.00	30
20x18	18.63 x 16.75	23.00	33.75	4.25	52.00	52.50	52.00	24.30	24.91	31.81	20	2.12	29.50	30
20x20	18.63 x 18.63	23.00	33.75	4.25	52.00	52.50	52.00	24.30	26.18	33.08	20	2.12	29.50	30
24x20	22.50 x 18.63	27.25	41.00	5.50	61.00	61.75	61.00	21.70	24.20	28.90	20	2.62	35.50	30
24x24	22.50 x 22.50	27.25	41.00	5.50	61.00	61.75	61.00	23.80	29.80	30.90	20	2.62	35.50	30
30x30	28.11 x 28.11	33.75	48.50	5.88	74.00	70.16	65.35	30.94	31.42	*	*	*	*	*
36x36	33.74 x 33.74	40.25	57.50	6.75	90.00	81.89	74.80	36.38	36.14	*	*	*	*	*
40x40	37.56 x 37.56	45.75	59.50	7.75	85.83	*	82.68	39.88	39.65	*	*	*	*	*
44x44	41.26 x 41.26	50.00	64.88	8.44	93.70	*	88.58	41.26	45.28	*	*	*	*	*
48x48	45.00 x 45.00	54.50	70.25	9.19	96.46	*	93.70	47.64	47.72	*	*	*	*	*

\* Contact your PBV® salesperson for additional sizes and materials.

## Class 1500 14"FP - 24"FP (in.)

SIZE	A	B	C	D2	E1-RF	E2-RTJ	E3-WE	F	G	H	N	M	P	L
14x14	12.50 x 12.50	16.25	29.50	5.25	49.50	50.25	49.50	20.60	18.83	25.73	16	2.38	25.00	30
16x14	14.25 x 12.50	18.50	32.50	5.75	54.50	55.38	54.50	22.27	18.83	25.73	16	2.62	27.75	30
16x16	14.25 x 14.25	18.50	32.50	5.75	54.50	55.38	54.50	22.27	20.50	27.40	16	2.62	27.75	30
18x16	16.75 x 14.25	21.00	36.00	6.38	60.50	61.38	60.50	23.39	20.50	27.40	16	2.88	30.50	30
18x18	16.75 x 16.75	21.00	36.00	6.38	60.50	61.38	60.50	23.39	24.91	31.81	16	2.88	30.50	30
20x18	17.88 x 16.00	23.00	38.75	7.00	65.50	66.38	65.50	23.39	24.96	31.81	16	3.12	32.75	30
20x20	18.63 x 18.63	23.00	38.75	7.00	65.50	66.38	65.50	21.70	27.50	28.90	16	3.12	32.75	30
24x20	21.50 x 18.63	27.25	46.00	8.00	80.50	81.63	80.50	21.70	27.50	28.90	16	3.62	39.00	30
24x24	21.50 x 21.50	27.25	46.00	8.00	80.50	81.63	80.50	23.80	33.70	30.90	16	3.62	39.00	30

Contact your PBV® salesperson for additional sizes and materials.



# SERIES 5700/6700 • TOP WORKS DATA ▶▶▶

Data contained below is based on ball bore size and not end flange bore sizes. All dimensions are given in inches.

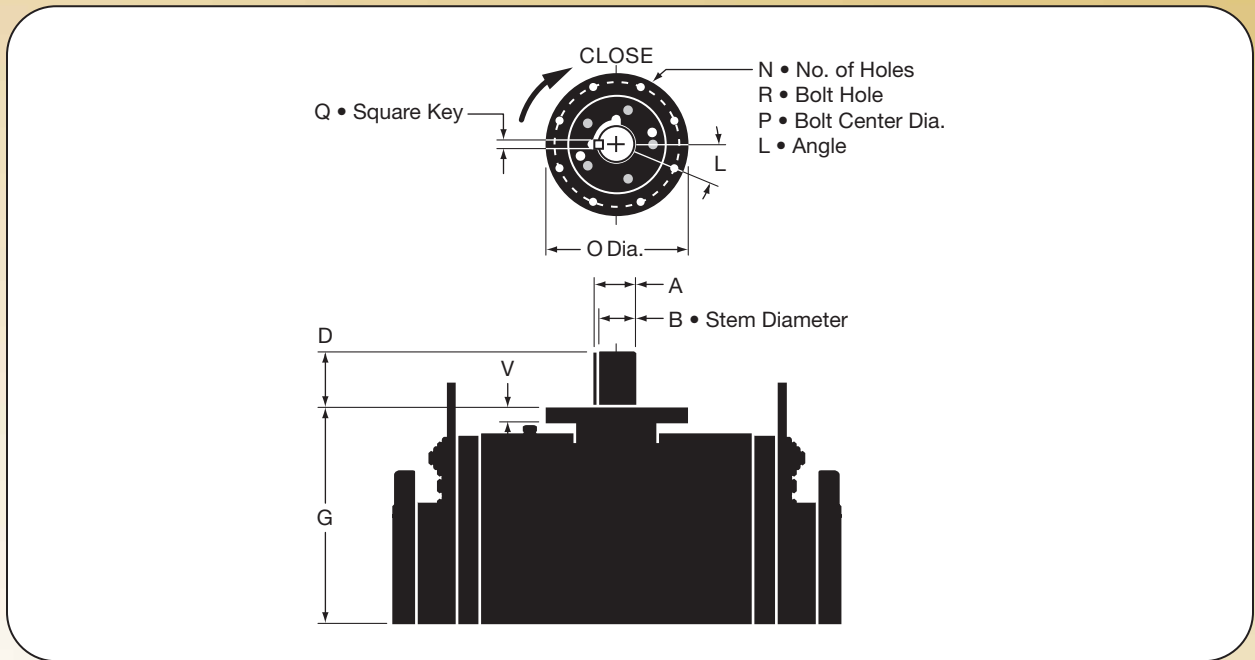

## Class 150 and 300 (in.)

SIZE	2	3	4	6	8	10	12	14	16	18	20	24
A	1.142	1.595	1.791	1.997	2.630	2.633	2.633	3.264	3.264	3.882	3.882	3.879
B	0.979	1.373	1.570	1.765	2.362	2.362	2.362	2.950	2.950	3.540	3.540	3.540
D	1.53	1.83	1.80	3.64	3.49	3.56	3.51	4.36	4.36	5.30	5.29	5.49
G	4.87**	5.94	7.35	8.48	10.13	11.96	13.75	14.31	15.89	19.76	20.20	23.34
L	45°	45°	22.5°	22.5°	22.5°	22.5°	22.5°	22.5°	22.5°	22.5°	22.5°	22.5°
N	4	4	4	8	8	8	8	8	8	8	8	8
O	6.90	8.00	8.75	10.00	11.22	11.22	11.22	11.40	11.40	11.40	11.40	16.00
P	5.50	6.50	7.50	8.86	9.84	9.84	9.84	10.00	10.00	10.00	10.00	14.02
Q	0.315	0.394	0.394	0.500	0.625	0.625	0.625	0.750	0.750	0.875	0.875	0.875
R	0.69	0.81	0.69	0.65	0.65	0.65	0.65	0.69	0.69	0.69	0.69	1.13
V	0.53	0.60	0.53	0.91	1.09	1.09	1.09	1.35	1.35	1.00	1.00	1.00

SIZE	30	36	40	44	48	52	56
A	6.554	6.554	*	*	*	*	*
B	5.900	5.900	*	*	*	*	*
D	7.90	7.90	*	*	*	*	*
G	30.08	33.83	*	*	*	*	*
L	22.5°	22.5°	*	*	*	*	*
N	8	8	*	*	*	*	*
O	22.62	22.62	*	*	*	*	*
P	20.31	20.31	*	*	*	*	*
Q	1.500	1.500	*	*	*	*	*
R	1.31	1.31	*	*	*	*	*
V	2.00	2.00	*	*	*	*	*

\* Contact your PBV® salesperson for additional sizes and materials.

\*\* Lipseal design may vary.



# SERIES 5700/6700 • TOP WORKS DATA CONTINUED ▶ ▶ ▶

## Class 600 (in.)

SIZE	2	3	4	6	8	10	12	14	16	18	20	24
A	1.142	1.595	1.791	1.997	2.630	2.630	2.630	3.264	3.264	3.882	3.882	5.291
B	0.979	1.373	1.570	1.765	2.362	2.362	2.362	2.950	2.950	3.540	3.540	4.725
D	1.53	1.83	1.80	3.64	3.54	3.52	3.59	4.36	4.36	5.30	5.40	5.51
G	4.87	5.94	7.35	8.48	11.57	13.32	14.94	14.31	15.89	19.76	20.09	24.35
L	45°	45°	22.5°	22.5°	22.5°	22.5°	22.5°	22.5°	22.5°	22.5°	22.5°	22.5°
N	4	4	4	8	8	8	8	8	8	8	8	8
O	6.90	8.00	8.75	10.00	11.22	11.22	11.22	11.40	11.40	11.40	16.00	16.00
P	5.50	6.50	7.50	8.86	9.84	9.84	10.00	10.00	10.00	10.00	14.02	14.02
Q	0.315	0.394	0.394	0.500	0.625	0.625	0.625	0.750	0.750	0.875	0.875	1.250
R	0.69	0.81	0.69	0.65	0.65	0.65	0.69	0.69	0.69	0.69	1.13	1.13
V	0.53	0.60	0.53	0.91	1.09	1.09	1.09	1.35	1.35	1.00	1.00	2.00

SIZE	30	36	40	44	48	52	56
A	6.554	6.554	*	*	*	*	*
B	5.900	5.900	*	*	*	*	*
D	7.90	7.90	*	*	*	*	*
G	30.08	33.83	*	*	*	*	*
L	22.5°	22.5°	*	*	*	*	*
N	8	8	*	*	*	*	*
O	22.62	22.62	*	*	*	*	*
P	20.31	20.31	*	*	*	*	*
Q	1.500	1.500	*	*	*	*	*
R	1.31	1.31	*	*	*	*	*
V	2.00	2.00	*	*	*	*	*

\* Contact your PBV® salesperson for additional sizes and materials.

## Class 900 (in.)

SIZE	2	3	4	6	8	10	12*	14	16	18	20	24
A	1.142	1.595	1.791	1.997	2.630	2.630	3.261	3.882	3.882	5.291	5.291	6.550
B	0.979	1.373	1.570	1.765	2.362	2.362	2.950	3.540	3.540	4.725	4.725	5.900
D	1.53	1.83	1.80	3.75	3.54	3.52	5.56	5.03	6.03	5.44	6.66	7.905
G	4.87**	5.94	7.35	10.01	11.57	13.32	15.46	16.76	18.87	23.84	24.18	27.92
L	45°	45°	22.5°	0°	22.5°	22.5°	22.5°	22.5°	22.5°	22.5°	22.5°	22.5°
N	4	4	4	8	8	8	8	8	8	8	8	8
O	6.90	8.00	8.75	11.22	11.22	11.22	13.19	11.70	16.00	16.00	16.00	22.62
P	5.50	6.50	7.50	9.84	9.84	10.00	11.78	10.00	14.02	14.02	14.02	20.31
Q	0.315	0.394	0.394	0.500	0.625	0.625	0.750	0.875	0.875	1.250	1.250	1.50
R	0.69	0.81	0.69	0.69	0.65	0.69	0.81	0.69	1.12	1.12	1.12	1.31
V	0.53	0.60	0.53	1.25	1.09	1.09	1.35	1.54	1.54	2.00	1.50	2.25

Contact your PBV® salesperson for additional sizes and materials.

\* Design change May 2004. Serial number required to verify design.

\*\* Lip seal design may vary.



# SERIES 5700/6700 • TOP WORKS DATA CONTINUED ▶▶▶

Data contained below is based on ball bore size and not end flange bore sizes. All dimensions are given in inches.

Dimensions may be changed without notice. Contact PBV® with **valve serial numbers** for exact dimensions.

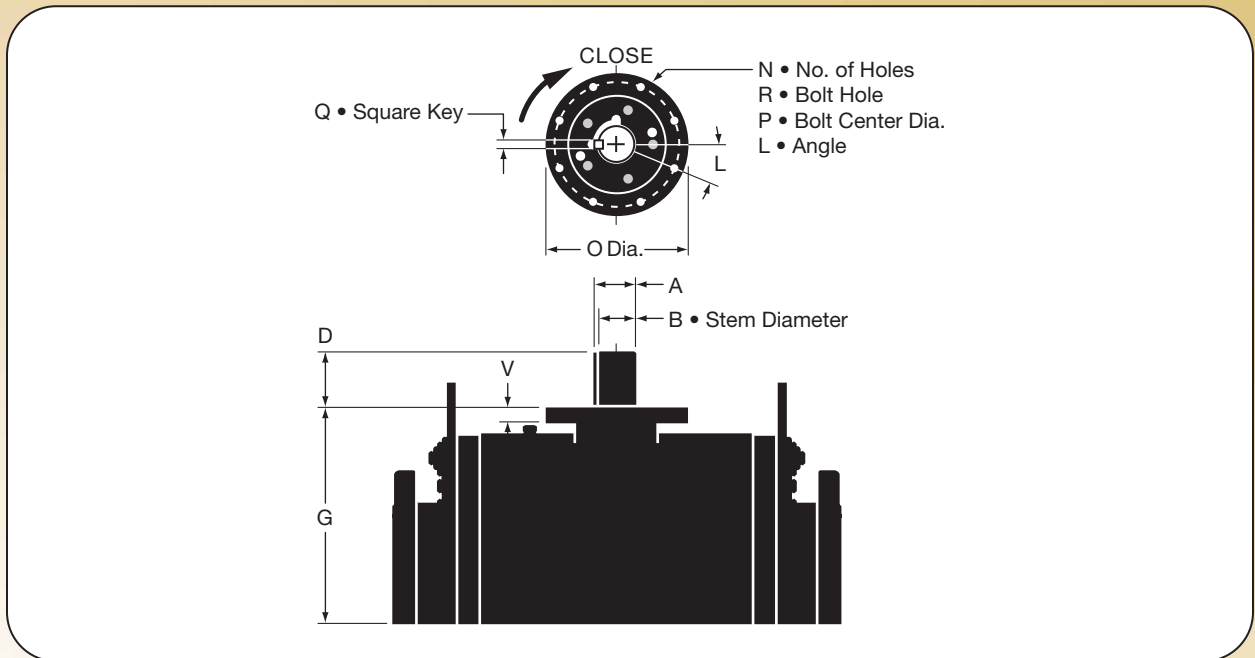

## Class 1500 (in.)

SIZE	2	3	4	6	8	10	12	14	16	18	20	24
A	1.142	1.595	1.792	2.630	3.264	3.264	3.264	3.882	3.882	5.291	5.291	6.554
B	.980	1.375	1.572	2.362	2.950	2.950	2.950	3.540	3.540	4.725	4.725	5.900
D	1.68	2.07	2.09	3.87	5.87	5.87	5.86	6.03	6.03	5.50	6.63	6.84
G	5.47	6.42	7.88	10.67	12.88	15.48	17.83	18.83	20.50	24.87	27.46	33.69
L	45°	45°	22.5°	0°	22.5°	22.5°	22.5°	22.5°	22.5°	22.5°	22.5°	22.5°
N	4	4	4	8	8	8	8	8	8	8	8	8
O	7.00	8.00	8.80	11.22	13.19	13.19	13.19	16.00	16.00	16.00	16.00	22.62
P	5.50	6.50	7.50	9.84	11.78	11.78	11.78	14.02	14.02	14.02	14.02	20.31
Q	0.315	0.394	0.394	.615	0.750	0.750	0.750	0.875	0.875	1.250	1.250	1.250
R	0.69	0.81	0.69	0.65	0.78	0.78	0.78	1.12	1.12	1.12	1.12	1.31
V	0.49	0.60	1.00	1.25	1.35	1.35	1.35	1.54	1.54	2.00	1.50	2.00

## Class 2500 (in.)

SIZE	2	3	4	6	8	10	12
A	1.263	1.595	1.997	2.650	3.264	3.264	3.882
B	1.125	1.375	1.765	2.362	2.950	2.950	3.540
D	2.78	3.10	2.58	5.30	5.26	4.17	5.07
G	7.25	8.42	10.56	12.70	16.63	18.25	20.79
L*	22.5°	22.5°	22.5°	22.5°	22.5°	22.5°	22.5°
N	4	8	8	8	8	8	8
O	8.00	10.00	8.80	11.22	13.19	11.70	16.50
P	6.75	8.86	7.50	10.00	11.78	10.00	14.02
Q	0.315	0.394	0.500	0.625	0.750	0.750	0.875
R	0.66	0.66	0.69	0.69	0.78	0.69	1.12
V	0.80	0.85	0.90	1.75	1.75	1.50	1.50

\* Contact factory for mounting details.



## BORE SIZES • SHIPPING INFORMATION ▶▶▶

Bore sizes in PBV® ball valves conform to API 6D. They present an unobstructed flow path ideally suited for pigging when ordered in the full bore configuration.

NOMINAL BORE SIZE (IN.)	ACTUAL BORE SIZE (IN.)			
	ANSI 150-600	ANSI 900	ANSI 1500	ANSI 2500
2	2.00	2.00	2.00	1.75
3	3.00	3.00	3.00	2.50
4	4.00	4.00	4.00	3.50
6	6.00	6.00	5.75	5.25
8	8.00	8.00	7.63	7.13
10	10.00	10.00	9.50	8.88
12	12.00	12.00	11.38	10.50
14	13.25	12.75	—	—
16	15.25	14.75	—	—
18	17.25	16.75	—	—
20	19.25	18.63	—	—
24	23.25	22.50	—	—
26	25.00	—	—	—
28	27.00	—	—	—
30	29.00	—	—	—
32	30.75	—	—	—
34	32.75	—	—	—
36	34.50	—	—	—



### Weight (lbs.) and Shipping Dimensions (in.)

SIZE	ANSI 150		ANSI 300		ANSI 600		ANSI 900		ANSI 1500		ANSI 2500	
	WT.	SHIP DIM.	WT.	SHIP DIM.	WT.	SHIP DIM.	WT.	SHIP DIM.	WT.	SHIP DIM.	WT.	SHIP DIM.
2x2	60	7x8x14	65	9x7x14	70	12x7x14	115	15x11x16	120	15x10x17	385	18x11x18
3x2	75	8x10x14	90	11x9x14	100	14x9x14	130	15x12x16	175	19x13x17	480	23x14x18
3x3	110	8x10x17	125	11x9x16	140	14x9x17	175	15x12x16	230	19x13x18	605	23x14x20
4x3	140	9x12x17	150	12x11x16	200	17x12x17	240	18x15x16	260	22x15x18	770	27x17x20
4x4	190	9x12x19	220	12x11x19	270	17x12x19	330	18x15x22	385	22x15x20	880	27x17x20
6x4	270	16x14x19	285	16x14x19	395	22x15x19	550	24x20x22	700	27x19x20	1430	37x23x20
6x6	425	16x14x19	460	16x14x20	515	22x15x19	860	24x20x25	1155	28x19x25	2100	37x23x28
8x6	505	18x18x19	575	20x17x20	675	26x18x19	1070	29x24x25	1400	33x23x25	2580	41x26x28
8x8	565	18x18x22	715	20x17x22	1140	26x18x25	1410	29x24x30	1935	33x23x30	5500	41x26x36
10x8	640	21x21x22	820	22x19x22	1420	31x22x25	1760	33x28x30	2135	39x28x30	6710	51x32x36
10x10	960	21x21x26	1175	22x19x25	1700	31x22x28	2355	33x28x33	3430	39x28x33	7400	51x32x42
12x10	1100	24x25x26	1390	26x23x25	1895	33x24x28	2530	38x31x33	3930	45x32x33	9350	57x26x42
12x12	1310	27x25x29	1740	26x23x29	2310	33x24x34	3545	38x31x36	5180	45x32x36	10,500	57x36x46
14x12	1460	27x23x29	1970	30x25x29	2575	35x26x34	3740	41x33x36	5580	50x35x36	—	—
14x14	1870	27x23x35	2240	30x25x35	2505	35x26x36	4435	41x33x38	5300	50x35x38	—	—
16x14	2025	30x26x35	2480	33x28x35	3050	39x30x36	4650	45x36x38	6700	55x39x38	—	—
16x16	2520	34x28x39	3015	33x28x39	3505	39x30x40	6260	45x36x41	9120	55x39x41	—	—
18x16	2685	34x28x39	3225	36x31x39	3900	43x32x40	6450	49x40x41	9620	61x43x41	—	—
18x18	3300	34x28x43	3750	36x31x43	4550	43x32x44	8970	49x40x41	13,020	61x43x44	—	—
20x18	3482	36x30x43	3995	39x34x43	5095	47x35x44	9150	43x44x44	13,820	66x47x44	—	—
20x20	4465	36x30x47	5105	39x34x47	6100	47x35x47	11,380	53x44x51	16,500	66x47x51	—	—
24x20	4920	42x35x47	5730	45x40x47	7325	55x41x47	11,850	62x53x51	20,500	82x55x51	—	—
24x24	6910	42x35x58	8000	45x40x58	10,800	55x41x58	18,960	62x53x55	27,500	82x55x55	—	—

Contact your PBV® salesperson for additional weights/sizes larger than 24".

NOTES: 1) Weights and dimensions given for flanged end valves only.

2) Valves sizes 2"x2" through 6"x4" in all Classes are with Lever Operators. Valves sizes 6"x6" and larger in all Classes are with Gear Operators.

3) Shipping dimensions do not include Lever or Handwheel for Gear Operator.

The above weights and dimensions are made available for the purpose of estimating shipping expenses. These numbers are near approximations for the valve only exclusive of crating or palletizing.





**For more information about our products and full  
Terms & Conditions please visit [www.f-e-t.com](http://www.f-e-t.com).**



12735 Dairy Ashford Road Stafford, Texas 77477  
281.340.5400 [m] 800.256.6193 [tf] 281.340.5499 [f]  
[www.f-e-t.com](http://www.f-e-t.com)