



PARALLEL SLIDE GATE VALVES

ASME B16.34 Standard & Special Class



VALVES LTD



Cast Steel Parallel Slide Gate Valves

3	Product Review
4	Material & Parts Specification Class 150 Flanged Valves
5	Material & Parts Specification Class 150 Butt Weld Valves
6	Material & Parts Specification Class 300 Flanged Valves
7	Material & Parts Specification Class 300 Butt Weld Valves
8	Material & Parts Specification Class 600 Flanged Valves
9	Material & Parts Specification Class 600 Butt Weld Valves
10	Technical Data ASME B16.5 & BS4504 Flanges
11	Technical Data ASME B16.5 Flange Dimensions



Cast Steel Parallel Slide Gate Valves



- ASME B16.34 Standard and Special Class
- Overall length to ASME B16.10
- Pressure Classes 150, 300 & 600
- Flanged ends to ASME B16.5 or BS4504 PN Rated
- BWE connections to ASME B16.25
- Rising stem, outside screw and pillar design
- Stellite faced seats, discs & backseat
- Non-rising handwheel
- Open and shut position indication

Features and benefits of the Parallel Slide Valve:

- A parallel slide valve can accommodate large temperature changes without the risk of the body seats gripping the sealing element of the discs
- The pillar and stem-stop design provides accurate guidance for the valve stem and gives continuous visual position indication from open to closed
- The parallel slide valve design requires minimum torque to open or close the valve
- Gearbox or power actuators are not required for normal valve operation
- Where actuators are fitted, torque switches are not required and the operation requires significantly less output energy than that required for a wedge gate valve
- The seat and disc design creates a wiping action to avoid build up of deposits on the sealing faces
- The stuffing box and valve stem have been designed and manufactured to reduce fugitive emissions from the gland
- Expanded graphite preformed rings maintain an emissions level of 100 ppm
- To achieve emission levels of 50 ppm and below, a cup and cone packing design is specified in combination with the accurate stem and stuffing box tolerances
- The design provides easier in-line maintenance since only the seat faces need to be nominally parallel
- The bonnet bolts and nuts are loaded to pre-determined values to ensure a pressure tight body/bonnet seal



MATERIAL & PARTS SPECIFICATION

Fig No. 5081 Flanged Ends, Class 150

ASME Class 150 Flanged Valve Dimensions

Size ins mm	Fig No	Weight lbs kgs	Length L	Flange Dia D	Height H (closed)	H/W Dia W
2"	5081	42	7	6	14 3/4	8
50		19	178	152	375	200
2 1/2"	5081	68	7 1/2	7	17 1/2	8
65		31	191	178	445	200
3"	5081	77	8	7 1/2	19	9
80		35	203	191	483	225
4"	5081	115	9	9	23	10
100		52	229	229	584	250
5"	5081	159	10	10	27	12
125		72	254	254	685	300
6"	5081	198	10 1/2	11	28 1/2	14
150		90	267	279	725	350
8"	5081	324	11 1/2	13 1/2	38 1/2	16
200		147	292	343	980	400
10"	5081	591	13	16	44	18
250		268	330	406	1120	450
12"	5081	701	14	19	48 1/2	20
300		318	356	483	1230	500
14"	5081	814	15	21	53	24
350		369	381	533	1345	600
16"	5081	1195	16	23 1/2	59	24
400		542	406	597	1500	600
18"	5081	1555	17	25	66	24
450		705	432	635	1675	600
20"	5081	2000	18	27 1/2	74	28
500		907	457	699	1880	700
24"	5081	2822	20	32	86	30*
600		1280	508	813	2185	750*

* Valve may require gear operators

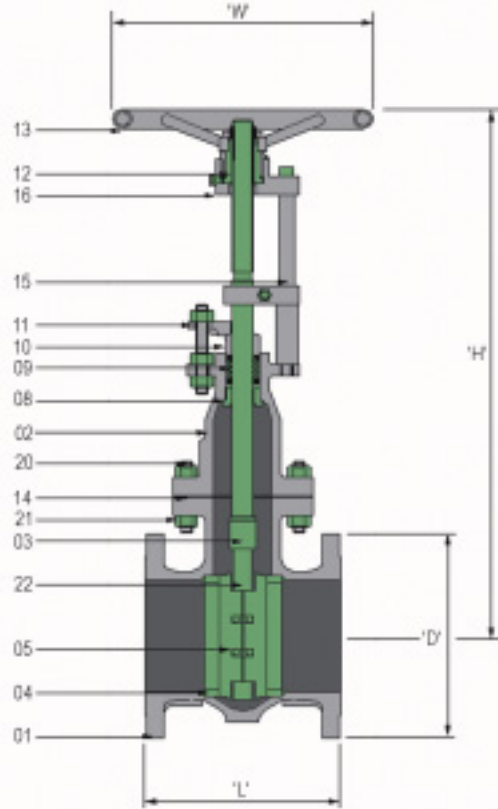

Materials of Construction

Part No	Part Description	Carbon Steel Specification	Alloy Steel Specification
1	Body	ASTM A216 Gr. WCB †	ASTM A217 Gr. WC6 or WC9
2	Bonnet	ASTM A216 Gr. WCB †	ASTM A217 Gr. WC6 or WC9
3	Stem	ASTM A276 Gr. 410	ASTM A276 Gr. 410
4	Seat Ring	ASTM A105N - Hardfaced	ASTM A182 Gr. F11 or F22 - Hardfaced
5	Disc	ASTM A216 Gr. WCB - Hardfaced	ASTM A217 Gr. WC6 or WC9 - Hardfaced
8	Backseat Bush	ASTM A276 Gr. 410 - Hardfaced	ASTM A276 Gr. 410 - Hardfaced
9	Gland Packing	Flexible Graphite Rings with Braided Graphite End Rings	
10	Gland Follower	ASTM A276 Gr. 410	ASTM A276 Gr. 410
11	Gland Flange	ASTM A105N	ASTM A217 Gr. WC6 or WC9
12	Yoke Sleeve	ASTM A439 Gr. D2	ASTM A439 Gr. D2
13	Handwheel	Malleable Iron or Steel	Malleable Iron or Steel
14	Body/Bonnet Gasket	Stainless Steel Reinforced Tanged Graphite	
15	Pillar	ASTM A575 Gr. M1020	ASTM A575 Gr. M1020
16	Bridge	ASTM A216 Gr. WCB	ASTM A216 Gr. WCB
20	Body/Bonnet Studs	ASTM A193 Gr. B7	ASTM A193 Gr. B7
21	Body/Bonnet Nuts	ASTM A194 Gr. 2H	ASTM A194 Gr. 2H

† 0.25% Carbon max.

Hydrostatic Test Pressures

Body Material	Pressure Class 150	
	psi	bar
ASTM A216 Gr. WCB		
Shell	450	31.0
Seat	315	21.7
ASTM A217 Gr. WC6		
Shell	450	31.0
Seat	320	22.1
ASTM A217 Gr. WC9		
Shell	450	31.0
Seat	320	22.1



Fig No. 5091 Butt Weld Ends, Class 150

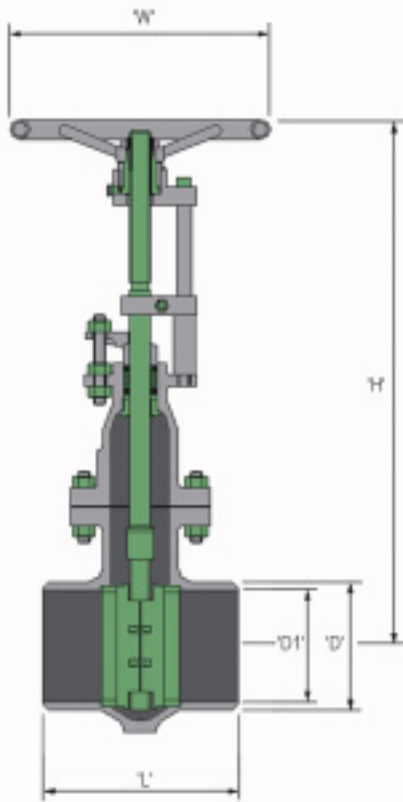

ASME Class 150 Butt Weld Valve Dimensions

Size ins	Fig No	Weight lbs	Length L	Weld Prep Dia D	Pipe Bore Sch 40 D1	Pipe Bore Sch 80 D1	Height H (closed)	H/W Dia W
2"	5091	40	8 1/2	2.38	2.07	1.94	14 3/4	8
50		18	216	60.3	52.5	49.2	375	200
2 1/2"	5091	64	9 1/2	2.96	2.47	2.32	17 1/2	8
65		29	241	75	62.5	59	445	200
3"	5091	71	11 1/8	3.59	3.07	2.90	19	9
80		32	283	91	78	73.5	483	225
4"	5091	104	12	4.62	4.03	3.83	23	10
100		47	305	117	102	97	584	250
5"	5091	146	15	5.69	5.05	4.81	27	12
125		66	381	144	128	122	685	300
6"	5091	183	15 7/8	6.78	6.07	5.76	28 1/2	14
150		83	403	172	154	146.5	725	350
8"	5091	300	16 1/2	8.78	7.98	7.63	38 1/2	16
200		136	419	223	203	193.5	980	400
10"	5091	556	18	10.94	10.02	9.56	44	18
250		252	457	278	254.5	243	1120	450
12"	5091	650	19 3/4	12.97	11.94	11.37	48 1/2	20
300		295	502	329	303	289	1230	500
14"	5091	743	22 1/2	14.25	13.12	12.50	53	24
350		337	572	362	333.5	317.5	1345	600
16"	5091	1105	24	16.25	15.00	14.31	59	24
400		501	610	413	381	363.5	1500	600
18"	5091	1455	26	18.28	16.88	16.12	66	24
450		660	660	464	428.5	409.5	1675	600
20"	5091	1874	28	20.31	18.81	17.94	74	28
500		850	711	516	478	455.5	1880	700
24"	5091	2646	32	24.38	22.62	21.56	86	30*
600		1200	813	619	574.5	547.5	2185	750*

* Valve may require gear operators

ASME B16.34 Standard Class and Special Class Pressure/Temperature Ratings

Class 150 Imperial Units

Fig No	End Conn	ASTM Body Material	ASME B16.34 Class	Working Pressure in psig														Temperature in °F						
				-20 to 100	200	300	400	500	600	650	700	750	800	850	900	950	975	1000	1025	1050	1075	1100		
5081	Flanged	A216 WCB	Standard	285	260	230	200	170	140	125	110	95	80	65*	-	-	-	-	-	-	-	-	-	-
5091	BWE	A216 WCB	Standard	285	260	230	200	170	140	125	110	95	80	65*	-	-	-	-	-	-	-	-	-	-
5091-XR	BWE	A216 WCB	Special	290	290	290	290	290	275	270	265	240	200	130*	-	-	-	-	-	-	-	-	-	-
L5081	Flanged	A217 WC6	Standard	290	260	230	200	170	140	125	110	95	80	65	50	35	28	20	-	-	-	-	-	-
L5091	BWE	A217 WC6	Standard	290	260	230	200	170	140	125	110	95	80	65	50	35	28	20	20	20	20	20	20	20
L5091-XR	BWE	A217 WC6	Special	290	290	290	290	290	290	280	280	280	275	260	225	155	130	105	87	70	58	45	-	-
R5081	Flanged	A217 WC9	Standard	290	260	230	200	170	140	125	110	95	80	65	50	35	28	20	-	-	-	-	-	-
R5091	BWE	A217 WC9	Standard	290	260	230	200	170	140	125	110	95	80	65	50	35	28	20	20	20	20	20	20	20
R5091-XR	BWE	A217 WC9	Special	290	290	285	280	275	275	275	275	265	260	245	230	180	153	125	105	85	70	55	-	-

Class 150 Metric Units

Fig No	End Conn	ASTM Body Material	ASME B16.34 Class	Working Pressure in barg										Temperature in °C										
				- 29 to 38	50	100	150	200	250	300	325	350	375	400	425	450	475	500	525	550	575	595		
5081	Flanged	A216 WCB	Standard	19.7	19.3	17.7	15.8	14.0	12.1	10.2	9.3	8.4	7.4	6.5	5.6	4.6*	-	-	-	-	-	-	-	-
5091	BWE	A216 WCB	Standard	19.7	19.3	17.7	15.8	14.0	12.1	10.2	9.3	8.4	7.4	6.5	5.6	4.6*	-	-	-	-	-	-	-	-
5091-XR	BWE	A216 WCB	Special	20.0	20.0	20.0	20.0	20.0	20.0	19.3	18.8	18.5	18.0	16.4	14.0	9.7*	-	-	-	-	-	-	-	-
L5081	Flanged	A217 WC6	Standard	20.0	19.5	17.7	15.8	14.0	12.1	10.2	9.3	8.4	7.4	6.5	5.6	4.6	3.7	2.8	1.9	1.4	-	-	-	-
L5091	BWE	A217 WC6	Standard	20.0	19.5	17.7	15.8	14.0	12.1	10.2	9.3	8.4	7.4	6.5	5.6	4.6	3.7	2.8	1.9	1.4	1.4	1.4	1.4	1.4
L5091-XR	BWE	A217 WC6	Special	20.0	20.0	20.0	20.0	20.0	20.0	20.0	20.0	19.8	19.3	19.3	19.0	18.1	16.1	12.4	8.8	6.2	4.2	3.0	-	-
R5081	Flanged	A217 WC9	Standard	20.0	19.5	17.7	15.8	14.0	12.1	10.2	9.3	8.4	7.4	6.5	5.6	4.6	3.7	2.8	1.9	1.4	-	-	-	-
R5091	BWE	A217 WC9	Standard	20.0	19.5	17.7	15.8	14.0	12.1	10.2	9.3	8.4	7.4	6.5	5.6	4.6	3.7	2.8	1.9	1.4	1.4	1.4	1.4	1.4
R5091-XR	BWE	A217 WC9	Special	20.0	20.0	20.0	19.6	19.3	19.0	19.0	19.0	19.0	18.9	18.3	17.9	17.1	16.1	13.7	10.4	7.4	5.2	3.7	-	-

*WCB material is permissible, but not recommended, for prolonged use above 800°F (425°C)
WC6 & WC9 materials are not to be used above 1100°F (595°C)

Flanged end ratings terminate at 1000°F (540°C)
For intermediate ratings use linear interpolation



MATERIAL & PARTS SPECIFICATION

Fig No. 5082 Flanged Ends, Class 300

ASME Class 300 Flanged Valve Dimensions

Size ins mm	Fig No	Weight lbs kgs	Length L	Flange Dia D	Height H (closed)	H/W Dia W
2"	5082	55	8 1/2	6 1/2	16 1/2	8
50		25	216	165	419	200
2 1/2"	5082	88	9 1/2	7 1/2	19	8
65		40	241	191	483	200
3"	5082	112	11 1/8	8 1/4	21 1/2	9
80		51	283	210	546	225
4"	5082	198	12	10	26 3/4	12
100		90	305	254	680	300
5"	5082	289	15	11	30	14
125		131	381	279	762	350
6"	5082	359	15 7/8	12 1/2	33	16
150		163	403	318	838	400
8"	5082	591	16 1/2	15	40 1/2	18
200		268	419	381	1030	450
10"	5082	864	18	17 1/2	44 1/2	20
250		392	457	445	1130	500
12"	5082	1147	19 3/4	20 1/2	49	24
300		520	502	521	1245	600
14"	5082	1929	30	23	54	24
350		875	762	584	1372	600
16"	5082	2470	33	25 1/2	63	30*
400		1120	838	648	1600	750*
18"	5082	2867	36	28	67	36*
450		1300	914	711	1700	900*
20"	5082	3970	39	30 1/2	78	36*
500		1800	991	775	1980	900*
24"	5082	6570	45	36	91	36*
600		2980	1143	914	2310	900*

* Valve may require gear operators

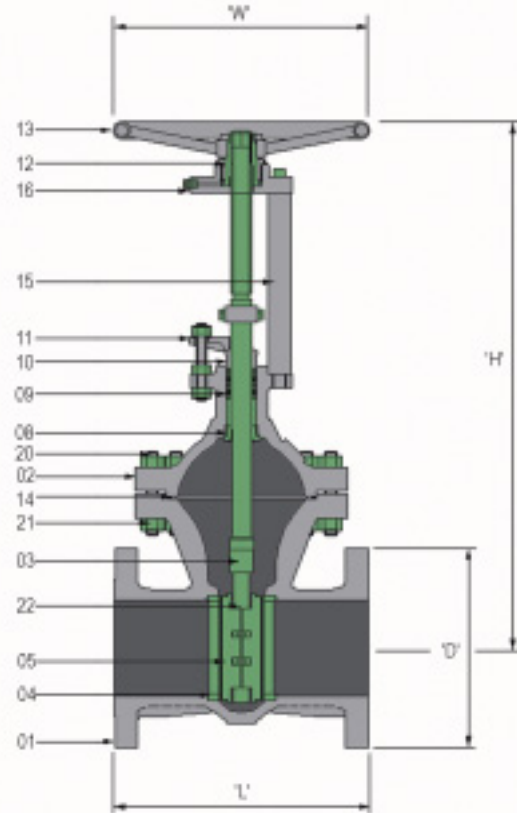

Materials of Construction

Part No	Part Description	Carbon Steel Specification	Alloy Steel Specification
1	Body	ASTM A216 Gr. WCB †	ASTM A217 Gr. WC6 or WC9
2	Bonnet	ASTM A216 Gr. WCB †	ASTM A217 Gr. WC6 or WC9
3	Stem	ASTM A276 Gr. 410	ASTM A276 Gr. 410
4	Seat Ring	ASTM A105N - Hardfaced	ASTM A182 Gr. F11 or F22 - Hardfaced
5	Disc	ASTM A216 Gr. WCB - Hardfaced	ASTM A217 Gr. WC6 or WC9 - Hardfaced
8	Backseat Bush	ASTM A276 Gr. 410 - Hardfaced	ASTM A276 Gr. 410 - Hardfaced
9	Gland Packing	Flexible Graphite Rings with Braided Graphite End Rings	
10	Gland Follower	ASTM A276 Gr. 410	ASTM A276 Gr. 410
11	Gland Flange	ASTM A105N	ASTM A217 Gr. WC6 or WC9
12	Yoke Sleeve	ASTM A439 Gr. D2	ASTM A439 Gr. D2
13	Handwheel	Malleable Iron or Steel	
14	Body/Bonnet Gasket	Stainless Steel Graphite Filled Spiral Wound	
15	Pillar	ASTM A575 Gr. M1020	ASTM A575 Gr. M1020
16	Bridge	ASTM A216 Gr. WCB	ASTM A216 Gr. WCB
20	Body/Bonnet Studs	ASTM A193 Gr. B7	ASTM A193 Gr. B7
21	Body/Bonnet Nuts	ASTM A194 Gr. 2H	ASTM A194 Gr. 2H

† 0.25% Carbon max.

Hydrostatic Test Pressures

Body Material	Pressure Class 300	
	psi	bar
ASTM A216 Gr. WCB		
Shell	1125	77.6
Seat	815	56.2
ASTM A217 Gr. WC6		
Shell	1125	77.6
Seat	825	56.9
ASTM A217 Gr. WC9		
Shell	1125	77.6
Seat	825	56.9



Fig No. 5092 Butt Weld Ends, Class 300

ASME Class 300 Butt Weld Valve Dimensions

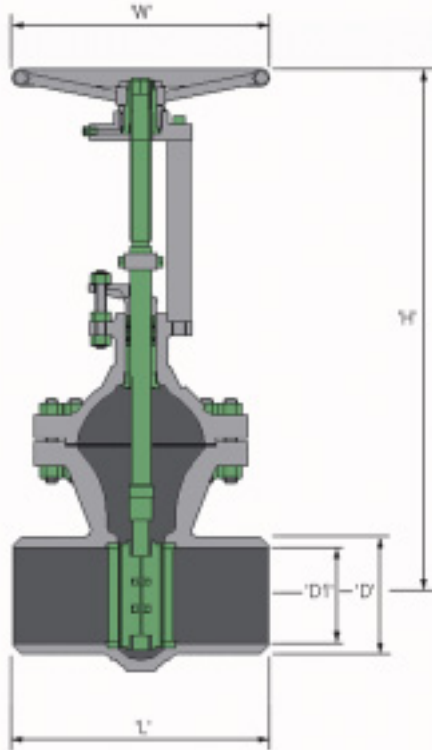

Size ins mm	Fig No	Weight lbs kgs	Length L	Weld Prep Dia D	Pipe Bore Sch 40 D1	Pipe Bore Sch 80 D1	Height H (closed)	H/W Dia W
2"	5092	49	8 1/2	2.38	2.07	1.94	16 1/2	8
50		22	216	60.3	52.5	49.2	419	200
2 1/2"	5092	79	9 1/2	2.96	2.47	2.32	19	8
65		36	241	75	62.5	59	483	200
3"	5092	99	11 1/8	3.59	3.07	2.90	21 1/2	9
80		45	283	91	78	73.5	546	225
4"	5092	179	12	4.62	4.03	3.83	26 3/4	12
100		81	305	117	102	97	680	300
5"	5092	262	15	5.69	5.05	4.81	30	14
125		119	381	144	128	122	762	350
6"	5092	326	15 7/8	6.78	6.07	5.76	33	16
150		148	403	172	154	146.5	838	400
8"	5092	540	16 1/2	8.78	7.98	7.63	40 1/2	18
200		245	419	223	203	193.5	1030	450
10"	5092	789	18	10.94	10.02	9.56	44 1/2	20
250		358	457	278	254.5	243	1130	500
12"	5092	1036	19 3/4	12.97	11.94	11.37	49	24
300		470	502	329	303	289	1245	600
14"	5092	1779	30	14.25	13.12	12.50	54	24
350		807	762	362	333.5	317.5	1372	600
16"	5092	2282	33	16.25	15.00	14.31	63	30*
400		1035	838	413	381	363.5	1600	750*
18"	5092	2624	36	18.28	16.88	16.12	67	36*
450		1190	914	464	428.5	409.5	1700	900*
20"	5092	3682	39	20.31	18.81	17.94	78	36*
500		1670	991	516	478	455.5	1980	900*
24"	5092	6152	45	24.38	22.62	21.56	91	36*
600		2790	1143	619	574.5	547.5	2310	900*

* Valve may require gear operators

ASME B16.34 Standard Class and Special Class Pressure/Temperature Ratings

Class 300 Imperial Units

Fig No	End Conn	ASTM Body Material	ASME B16.34 Class	Working Pressure in psig																Temperature in °F						
				-20 to 100	200	300	400	500	600	650	700	750	800	850	900	950	975	1000	1025	1050	1075	1100				
5082	Flanged	A216 WCB	Standard	740	675	655	635	600	550	535	535	505	410	270*	-	-	-	-	-	-	-	-	-	-	-	-
5092	BWE	A216 WCB	Standard	740	675	655	635	600	550	535	535	505	410	270*	-	-	-	-	-	-	-	-	-	-	-	-
5092-XR	BWE	A216 WCB	Special	750	750	750	750	750	715	700	695	630	515	335*	-	-	-	-	-	-	-	-	-	-	-	-
L5082	Flanged	A217 WC6	Standard	750	750	720	695	665	605	590	570	530	510	485	450	320	267	215	-	-	-	-	-	-	-	-
L5092	BWE	A217 WC6	Standard	750	750	720	695	665	605	590	570	530	510	485	450	320	267	215	180	145	120	95	-	-	-	-
L5092-XR	BWE	A217 WC6	Special	750	750	750	750	750	750	750	735	730	720	680	585	400	335	270	225	180	150	120	-	-	-	-
R5082	Flanged	A217 WC9	Standard	750	750	730	705	665	605	590	570	530	510	485	450	375	318	260	-	-	-	-	-	-	-	-
R5092	BWE	A217 WC9	Standard	750	750	730	705	665	605	590	570	530	510	485	450	375	318	260	218	175	143	110	-	-	-	-
R5092-XR	BWE	A217 WC9	Special	750	750	740	725	720	720	715	710	690	675	645	600	470	398	325	272	220	178	135	-	-	-	-

Class 300 Metric Units

Fig No	End Conn	ASTM Body Material	ASME B16.34 Class	Working Pressure in barg																Temperature in °C							
				- 29 to 38	50	100	150	200	250	300	325	350	375	400	425	450	475	500	525	550	575	595					
5082	Flanged	A216 WCB	Standard	51.0	50.0	46.4	45.1	43.9	41.8	38.9	37.6	36.9	36.6	34.6	28.7	20.2*	-	-	-	-	-	-	-	-	-	-	-
5092	BWE	A216 WCB	Standard	51.0	50.0	46.4	45.1	43.9	41.8	38.9	37.6	36.9	36.6	34.6	28.7	20.2*	-	-	-	-	-	-	-	-	-	-	-
5092-XR	BWE	A216 WCB	Special	51.7	51.7	51.7	51.7	51.7	51.7	50.0	48.9	48.2	47.3	43.1	36.0	25.1*	-	-	-	-	-	-	-	-	-	-	-
L5082	Flanged	A217 WC6	Standard	51.7	51.7	51.5	49.6	48.1	46.2	42.9	41.4	40.3	38.9	36.5	35.2	33.7	31.7	25.3	18.2	12.7	-	-	-	-	-	-	-
L5092	BWE	A217 WC6	Standard	51.7	51.7	51.5	49.6	48.1	46.2	42.9	41.4	40.3	38.9	36.5	35.2	33.7	31.7	25.3	18.2	12.7	8.8	6.4	-	-	-	-	-
L5092-XR	BWE	A217 WC6	Special	51.7	51.7	51.7	51.7	51.7	51.7	51.7	51.7	51.5	50.6	50.3	49.7	47.3	42.0	32.2	22.7	15.9	11.0	8.1	-	-	-	-	-
R5082	Flanged	A217 WC9	Standard	51.7	51.7	51.5	50.3	48.7	46.3	42.9	41.4	40.3	38.9	36.5	35.2	33.7	31.7	27.7	21.6	15.3	-	-	-	-	-	-	-
R5092	BWE	A217 WC9	Standard	51.7	51.7	51.5	50.3	48.7	46.3	42.9	41.4	40.3	38.9	36.5	35.2	33.7	31.7	27.7	21.6	15.3	10.5	7.4	-	-	-	-	-
R5092-XR	BWE	A217 WC9	Special	51.7	51.7	51.6	51.0	50.1	49.7	49.6	49.5	49.2	48.8	47.5	46.6	44.8	42.2	35.6	27.0	19.2	13.2	9.1	-	-	-	-	-

* WCB material is permissible, but not recommended, for prolonged use above 800°F (425°C)

WC6 & WC9 materials are not to be used above 1100°F (595°C)

Flanged end ratings terminate at 1000°F (540°C)

For intermediate ratings use linear interpolation



MATERIAL & PARTS SPECIFICATION

Fig No. 5084 Flanged Ends, Class 600

ASME Class 600 Flanged Valve Dimensions

Size ins mm	Fig No	Weight lbs kgs	Length L	Flange Dia D	Height H (closed)	H/W Dia W
2"	5084	82	11 1/2	6 1/2	16 1/2	10
50		37	292	165	419	250
2 1/2"	5084	170	13	7 1/2	19	12
65		77	330	191	483	300
3"	5084	201	14	8 1/4	21 1/2	12
80		91	356	210	546	300
4"	5084	302	17	10 3/4	26 3/4	14
100		137	432	273	680	350
5"	5084	456	20	13	32	18
125		207	508	330	813	450
6"	5084	587	22	14	36	18
150		266	559	356	914	450
8"	5084	1052	26	16 1/2	42	24
200		477	660	419	1067	600
10"	5084	1649	31	20	51	28
250		748	787	508	1295	700
12"	5084	2492	33	22	54	30
300		1130	838	559	1370	750
14"	5084	3528	35	23 3/4	59	36*
350		1600	889	603	1500	900*
16"	5084	4575	39	27	70	36*
400		2075	991	686	1780	900*
18"	5084	6417	43	29 1/4	85	36*
450		2910	1092	743	2160	900*
20"	5084	7500	47	32	95	36*
500		3400	1194	813	2420	900*
24"	5084	9700	55	37	110	36*
600		4400	1397	940	2800	900*

* Valve may require gear operators

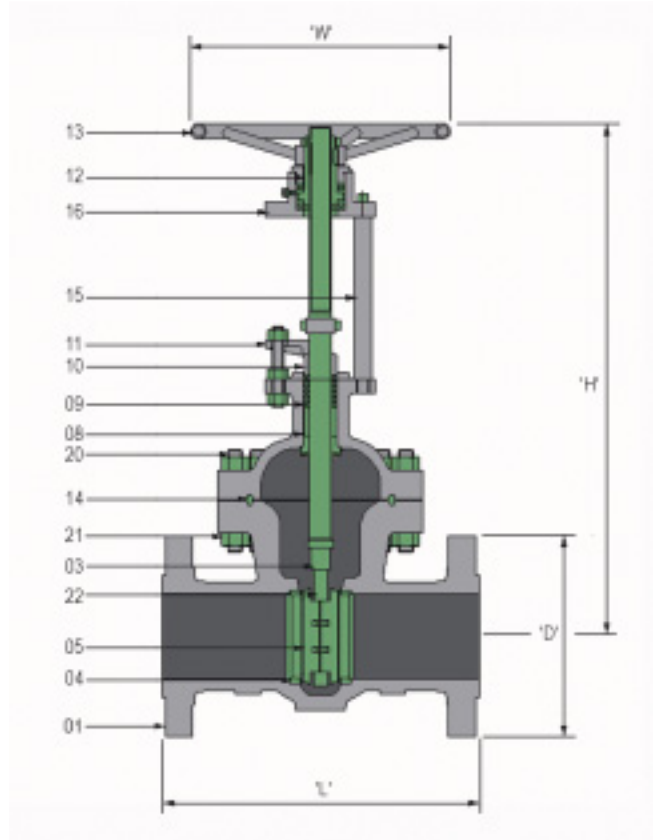

Materials of Construction

Part No	Part Description	Carbon Steel Specification	Alloy Steel Specification
1	Body	ASTM A216 Gr. WCB †	ASTM A217 Gr. WC6 or WC9
2	Bonnet	ASTM A216 Gr. WCB †	ASTM A217 Gr. WC6 or WC9
3	Stem	ASTM A276 Gr. 410	ASTM A276 Gr. 410
4	Seat Ring	ASTM A105N - Hardfaced	ASTM A182 Gr. F11 or F22 - Hardfaced
5	Disc	ASTM A216 Gr. WCB - Hardfaced	ASTM A217 Gr. WC6 or WC9 - Hardfaced
8	Backseat Bush	ASTM A276 Gr. 410 - Hardfaced	ASTM A276 Gr. 410 - Hardfaced
9	Gland Packing	Flexible Graphite Rings with Braided Graphite End Rings	
10	Gland Follower	ASTM A276 Gr. 410	ASTM A276 Gr. 410
11	Gland Flange	ASTM A105N	ASTM A217 Gr. WC6 or WC9
12	Yoke Sleeve	ASTM A439 Gr. D2	ASTM A439 Gr. D2
13	Handwheel	Malleable Iron or Steel	Malleable Iron or Steel
14	Body/Bonnet Gasket	Soft Iron Ring Joint	Stainless Steel Ring Joint
15	Pillar	ASTM A575 Gr. M1020	ASTM A575 Gr. M1020
16	Bridge	ASTM A216 Gr. WCB	ASTM A216 Gr. WCB
20	Body/Bonnet Studs	ASTM A193 Gr. B7	ASTM A193 Gr. B7
21	Body/Bonnet Nuts	ASTM A194 Gr. 2H	ASTM A194 Gr. 2H

† 0.25% Carbon max.

Hydrostatic Test Pressures

Body Material	Pressure Class 600	
	psi	bar
ASTM A216 Gr. WCB		
Shell	2225	153.4
Seat	1630	112.4
ASTM A217 Gr. WC6		
Shell	2250	155.1
Seat	1650	113.8
ASTM A217 Gr. WC9		
Shell	2250	155.1
Seat	1650	113.8

MATERIAL & PARTS SPECIFICATION



Fig No. 5094 Butt Weld Ends, Class 600

ASME Class 600 Butt Weld Valve Dimensions

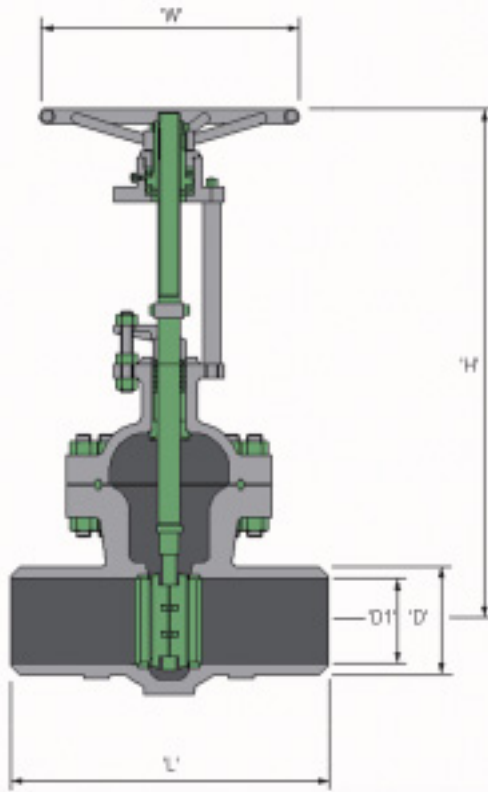

Size ins	Fig No	Weight lbs	Length L	Weld Prep Dia D	Pipe Bore Sch 40 D1	Pipe Bore Sch 80 D1	Height H (closed)	H/W Dia W
2"	5094	75	11 1/2	2.38	1.94	1.69	16 1/2	10
50		34	292	60.3	49.2	42.8	419	250
2 1/2"	5094	159	13	2.96	2.32	2.13	19	12
65		72	330	75	59	54	483	300
3"	5094	187	14	3.59	2.90	2.62	21 1/2	12
80		85	356	91	73.5	66.5	546	300
4"	5094	273	17	4.62	3.83	3.44	26 3/4	14
100		124	432	117	97	87.5	680	350
5"	5094	406	20	5.69	4.81	4.31	32	18
125		184	508	144	122	109.5	813	450
6"	5094	527	22	6.78	5.76	5.19	36	18
150		239	559	172	146.5	132	914	450
8"	5094	959	26	8.78	7.63	6.81	42	24
200		435	660	223	193.5	173	1067	600
10"	5094	1497	31	10.94	9.56	8.50	51	28
250		679	787	278	243	216	1295	700
12"	5094	2315	33	12.97	11.37	10.13	54	30
300		1050	838	329	289	257	1370	750
14"	5094	3330	35	14.25	12.50	11.19	59	36*
350		1510	889	362	317.5	284	1500	900*
16"	5094	4278	39	16.25	14.31	12.81	70	36*
400		1940	991	413	363.5	325.5	1780	900*
18"	5094	6064	43	18.28	16.12	14.44	85	36*
450		2750	1092	464	409.5	366.5	2160	900*
20"	5094	7056	47	20.31	17.94	16.06	95	36*
500		3200	1194	516	455.5	408	2420	900*
24"	5094	8985	55	24.38	21.56	19.31	110	36*
600		4075	1397	619	547.5	490.5	2800	900*

* Valve may require gear operators

ASME B16.34 Standard Class and Special Class Pressure/Temperature Ratings

Class 600 Imperial Units

Fig No	End Conn	ASTM Body Material	ASME B16.34 Class	-20 to		Working Pressure in psig										Temperature in °F							
				100	200	300	400	500	600	650	700	750	800	850	900	950	975	1000	1025	1050	1075	1100	
5084	Flanged	A216 WCB	Standard	1480	1350	1315	1270	1200	1095	1075	1065	1010	825	535*	-	-	-	-	-	-	-	-	-
5094	BWE	A216 WCB	Standard	1480	1350	1315	1270	1200	1095	1075	1065	1010	825	535*	-	-	-	-	-	-	-	-	-
5094-XR	BWE	A216 WCB	Special	1500	1500	1500	1500	1500	1425	1400	1390	1260	1030	670*	-	-	-	-	-	-	-	-	-
L5084	Flanged	A217 WC6	Standard	1500	1500	1445	1385	1330	1210	1175	1135	1065	1015	975	900	640	535	430	-	-	-	-	-
L5094	BWE	A217 WC6	Standard	1500	1500	1445	1385	1330	1210	1175	1135	1065	1015	975	900	640	535	430	360	290	240	190	150
L5094-XR	BWE	A217 WC6	Special	1500	1500	1500	1500	1500	1500	1500	1465	1460	1440	1355	1175	795	667	540	450	360	300	240	190
R5084	Flanged	A217 WC9	Standard	1500	1500	1455	1410	1330	1210	1175	1135	1065	1015	975	900	755	637	520	-	-	-	-	-
R5094	BWE	A217 WC9	Standard	1500	1500	1455	1410	1330	1210	1175	1135	1065	1015	975	900	755	637	520	435	350	285	220	170
R5094-XR	BWE	A217 WC9	Special	1500	1500	1485	1450	1440	1440	1430	1425	1380	1345	1285	1200	945	798	650	543	435	355	275	210

Class 600 Metric Units

Fig No	End Conn	ASTM Body Material	ASME B16.34 Class	- 29 to		Working Pressure in barg										Temperature in °C							
				38	50	100	150	200	250	300	325	350	375	400	425	450	475	500	525	550	575	595	
5084	Flanged	A216 WCB	Standard	102.0	100.1	92.8	90.6	87.8	83.6	77.5	75.0	74.0	72.9	69.1	57.6	40.1*	-	-	-	-	-	-	-
5094	BWE	A216 WCB	Standard	102.0	100.1	92.8	90.6	87.8	83.6	77.5	75.0	74.0	72.9	69.1	57.6	40.1*	-	-	-	-	-	-	-
5094-XR	BWE	A216 WCB	Special	103.4	103.4	103.4	103.4	103.4	103.4	99.7	97.7	96.4	94.6	86.2	72.0	50.2*	-	-	-	-	-	-	-
L5084	Flanged	A217 WC6	Standard	103.4	103.4	103.0	99.5	95.8	92.4	85.7	82.6	80.4	77.6	73.3	70.2	67.7	63.4	50.6	36.6	25.4	-	-	-
L5094	BWE	A217 WC6	Standard	103.4	103.4	103.0	99.5	95.8	92.4	85.7	82.6	80.4	77.6	73.3	70.2	67.7	63.4	50.6	36.6	25.4	17.7	12.8	8.9
L5094-XR	BWE	A217 WC6	Special	103.4	103.4	103.4	103.4	103.4	103.4	103.4	103.4	102.8	101.0	100.6	99.4	94.4	84.2	64.2	45.3	31.8	22.0	16.2	11.3
R5084	Flanged	A217 WC9	Standard	103.4	103.4	103.0	100.3	97.5	92.7	85.7	82.6	80.4	77.6	73.3	70.2	67.7	63.4	55.7	43.3	30.7	-	-	-
R5094	BWE	A217 WC9	Standard	103.4	103.4	103.0	100.3	97.5	92.7	85.7	82.6	80.4	77.6	73.3	70.2	67.7	63.4	55.7	43.3	30.7	21.1	14.8	10.0
R5094-XR	BWE	A217 WC9	Special	103.4	103.4	103.3	102.3	100.2	99.4	99.3	99.0	98.5	97.8	95.1	92.9	89.3	84.3	71.5	54.2	38.3	26.2	18.5	13.6

* WCB material is permissible, but not recommended, for prolonged use above 800°F (425°C)

WC6 & WC9 materials are not to be used above 1100°F (595°C)

Flanged end ratings terminate at 1000°F (540°C)

For intermediate ratings use linear interpolation



Flange Dimensions for ASME B16.5

ASME Class 150 - 1/16" Raised Face							
Nominal Size	Flange Diameter	Min Flange Thickness	Bolt Circle Diameter	Bolt Hole Diameter	No of Bolts	Diameter of Bolts	Raised Face Diameter
2"	6.00	0.62	4.75	0.75	4	5/8	3.62
2½"	7.00	0.69	5.50	0.75	4	5/8	4.12
3"	7.50	0.75	6.00	0.75	4	5/8	5.00
4"	9.00	0.94	7.50	0.75	8	5/8	6.19
5"	10.00	0.94	8.50	0.88	8	3/4	7.31
6"	11.00	1.00	9.50	0.88	8	3/4	8.50
8"	13.50	1.12	11.75	0.88	8	3/4	10.62
10"	16.00	1.19	14.25	1.00	12	7/8	12.75
12"	19.00	1.25	17.00	1.00	12	7/8	15.00
14"	21.00	1.38	18.75	1.12	12	1	16.25
16"	23.50	1.44	21.25	1.12	16	1	18.50
18"	25.00	1.56	22.75	1.25	16	1.1/8	21.00
20"	27.50	1.69	25.00	1.25	20	1.1/8	23.00
24"	32.00	1.88	29.50	1.38	20	1.1/4	27.25

ASME Class 300 - 1/16" Raised Face							
Nominal Size	Flange Diameter	Min Flange Thickness	Bolt Circle Diameter	Bolt Hole Diameter	No of Bolts	Diameter of Bolts	Raised Face Diameter
2"	6.50	0.88	5.00	0.75	8	5/8	3.62
2½"	7.50	1.00	5.88	0.88	8	3/4	4.12
3"	8.25	1.12	6.62	0.88	8	3/4	5.00
4"	10.00	1.25	7.88	0.88	8	3/4	6.19
5"	11.00	1.38	9.25	0.88	8	3/4	7.31
6"	12.50	1.44	10.62	0.88	12	3/4	8.50
8"	15.00	1.62	13.00	1.00	12	7/8	10.62
10"	17.50	1.88	15.25	1.12	16	1	12.75
12"	20.50	2.00	17.75	1.25	16	1.1/8	15.00
14"	23.00	2.12	20.25	1.25	20	1.1/8	16.25
16"	25.50	2.25	22.50	1.38	20	1.1/4	18.50
18"	28.00	2.38	24.75	1.38	24	1.1/4	21.00
20"	30.50	2.50	27.00	1.38	24	1.1/4	23.00
24"	36.00	2.75	32.00	1.62	24	1.1/2	27.25

ASME Class 600 - 1/4" Raised Face							
Nominal Size	Flange Diameter	Min Flange Thickness	Bolt Circle Diameter	Bolt Hole Diameter	No of Bolts	Diameter of Bolts	Raised Face Diameter
2"	6.50	1.00	5.00	0.75	8	5/8	3.62
2½"	7.50	1.12	5.88	0.88	8	3/4	4.12
3"	8.25	1.25	6.62	0.88	8	3/4	5.00
4"	10.75	1.50	8.50	1.00	8	7/8	6.19
5"	13.00	1.75	10.50	1.12	8	1	7.31
6"	14.00	1.88	11.50	1.12	12	1	8.50
8"	16.50	2.19	13.75	1.25	12	1.1/8	10.62
10"	20.00	2.50	17.00	1.38	16	1.1/4	12.75
12"	22.00	2.62	19.25	1.38	20	1.1/4	15.00
14"	23.75	2.75	20.75	1.50	20	1.3/8	16.25
16"	27.00	3.00	23.75	1.62	20	1.1/2	18.50
18"	29.25	3.25	25.75	1.75	20	1.5/8	21.00
20"	32.00	3.50	28.50	1.75	24	1.5/8	23.00
24"	37.00	4.00	33.00	2.00	24	1.7/8	27.25

Dimensions are in inches



DISTRIBUTED BY:



VALVES LTD

JANUARY 2003

HH VALVES LTD.
UNIT 4, LEOPOLD CENTRE,
SMETHURST LANE, PEMBERTON, WIGAN, WN5 8EG
TELEPHONE: +44 (0)1942 218 111 FAX: +44 (0)1942 224 800
EMAIL: sales@hhvalves.com WEB: www.hhvalves.com

Our policy is one of continuous development and improvement and we therefore retain the right to alter specifications at any time and without notice. Every effort is made to produce up-to-date literature but this brochure should not be regarded as an infallible guide to current specification and does not form part of any contract.