



Southern California Valve

(281) 482-4728 • www.scvvalve.com



Thru Conduit Slab & Expanding Gate Valves

Class: 150 - 1500

Sizes: 2" - 36"

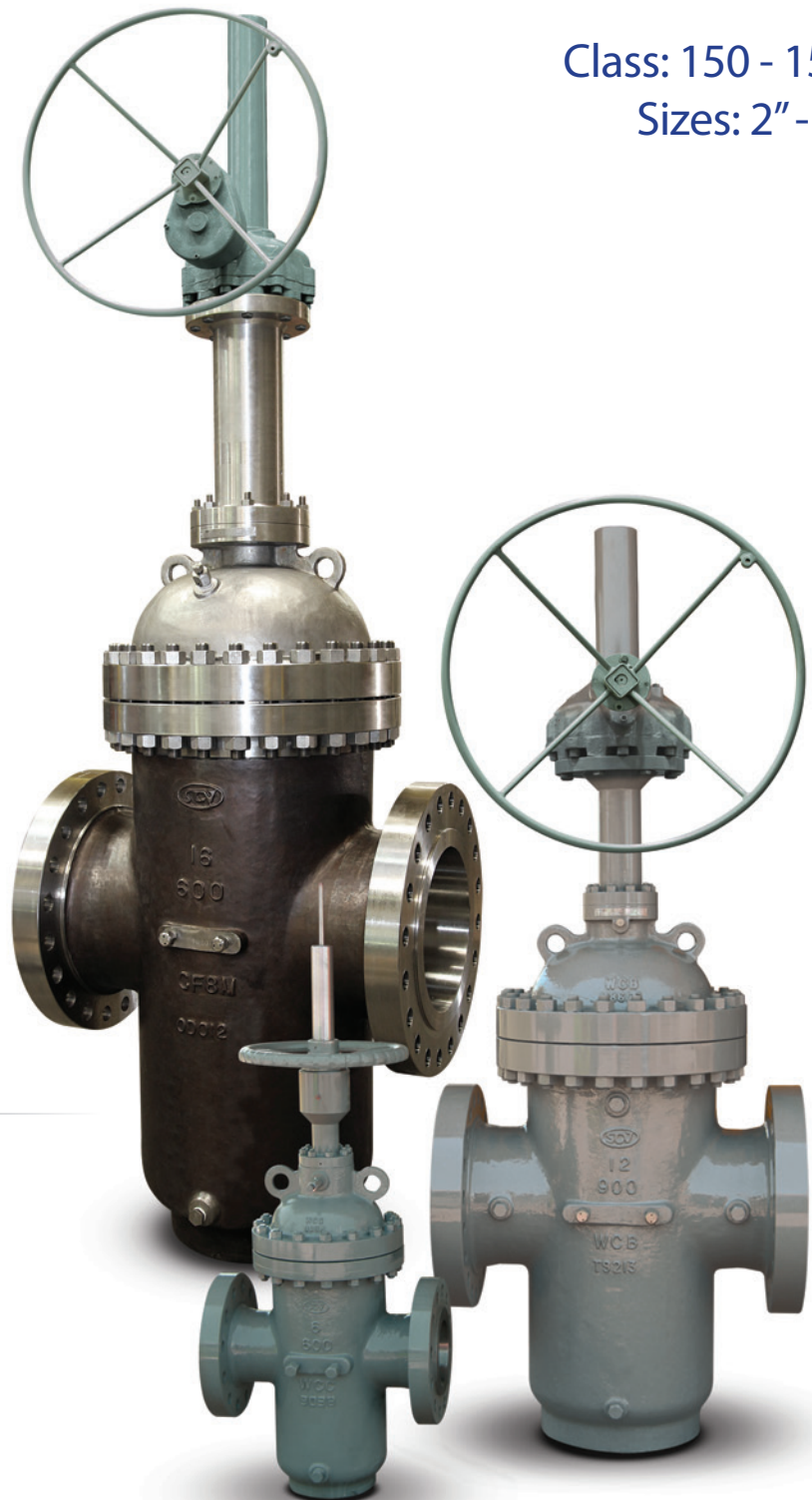



Southern California Valve

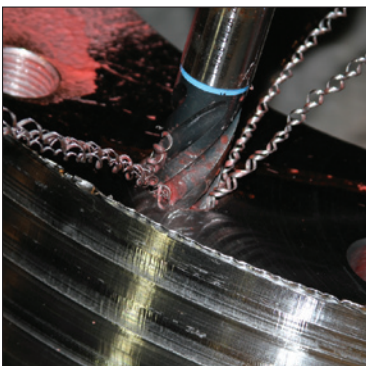
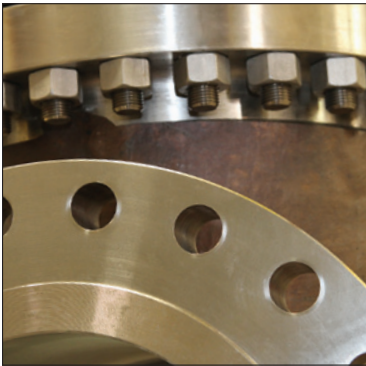

SOUTHERN CALIFORNIA VALVE manufactures some of the most dependable cast steel Thru Conduit Slab and Expanding Gate Valves in the industry. Both designs utilize flanged and butt-weld end connections, and are manufactured and tested in accordance with API 6D. The full port bi-directional flow capability minimizes pressure drop and turbulence. The SCV design offers many features and options beneficial for oil, gas, and liquid applications making it the most demanded Thru Conduit Gate on the market.

Innovative valve solutions.®

SCV Thru Conduit Slab & Expanding Gate Valves

[Product Preview]

For more information call us @ (281) 482-4728 or visit our website @ www.scvvalve.com

SCV THRU CONDUIT SLAB GATE

- Pressure assisted seats for high pressure sealing
- Spring loaded seat for low pressure sealing
- Double block and bleed capabilities
- Internal pressure relieving through self relieving seats
- Secondary sealant injection at seats and stems
- Full port thru conduit for passage of pigs

SCV THRU CONDUIT EXPANDING GATE

- Expanding mechanical gate forms positive tight sealing
- Seals at low and high pressure
- Double block and bleed capabilities
- Secondary sealant injections at seats and stems
- Optional by-pass system for thermal cavity relief venting
- Full port thru conduit for passage of pigs

BASIC DESIGN

API 6D

FACE TO FACE DIMENSION

ANSI B16.10

FLANGE END DIMENSION

ANSI B16.5 (2" to 24")
ANSI B16.47 & MSS SP-44 (26" & up)

BUTT-WELD END DIMENSION

ANSI B16.25

INSPECTION & TESTING

API 6D

Note: Not recommended for throttling applications.

Note: SCV reserves the right to change any technical design and dimensional data without prior notice. Please contact SCV to confirm all Dimensions and Data offered in this catalog.

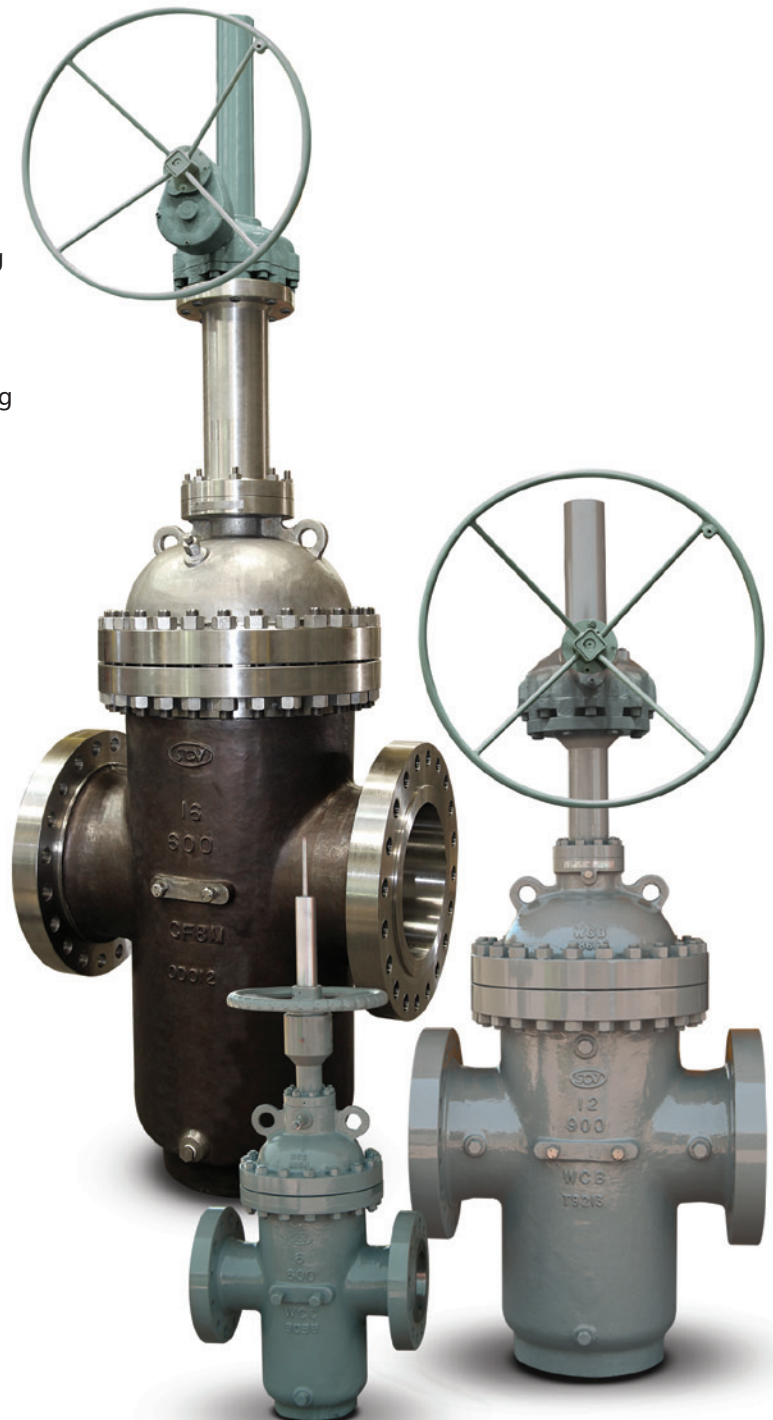



Southern California Valve

Southern California Valve's product lines include commodity valves as well as specialty valves in all Sizes, Pressure Classes & Metallurgy; including Carbon Steel, Stainless Steel & Exotic Alloys. The valve types include Gate, Globe, Swing Check - Bolted Bonnet & Pressure Seal Bonnet, Ball - floating, trunnion, rising stem, Thru-Conduit Gate - slab and expanding, Swing Check - Full and Regular Port, Lubricated Plugs, Dual Plate Checks - wafer and lug. Southern California Valve's High Quality Standards demand 100% pressure testing of every valve to insure its reliability and full customer satisfaction.

At Southern California Valve, we pride ourselves with high quality products in the commodity and specialty valve lines, as well as, timely deliveries, and competitive prices.

Company History ■ ■ ■ ■ ■ ■ ■ ■ ■ ■

Southern California Valve was established in 1972. The primary focus of the Company was to provide full inline field service for valve maintenance as well as in house valve modifications. While serving the Power Industry, Paper & Pulp, Oil & Gas, and the Petro Chemical Industry; through years of dedication and commitment to quality and service, Southern California Valve has become one of the largest West Coast full range, field service companies, with a reputation for superior quality.

In the mid 1970s, Southern California Valve entered the valve manufacturing industry, primarily serving the Power Industry. Since that time, Southern California Valve has expanded their products to cover a broad range of valves. Southern California Valve holds the API 6A & API 6D Monogram, API Q1 Quality Management System, and ASME "R" stamp. The Corporate office and manufacturing facility is located in Santa Fe Springs, California. The Sales and Projects office is located in Santa Fe, Texas.

Mission Statement ■ ■ ■ ■ ■ ■ ■ ■ ■ ■

Southern California Valve is committed to consistently providing products that meet or exceed customer and regulatory specifications. SCV aims to enhance customer satisfaction through implementing the highest levels of quality standards while assuring full conformity to those requirements.

Table of Contents

	Page
Table of Contents.....	1
Complete Product Line.....	2
Certifications	3
• American Petroleum Institute (API)	
• ISO 9001:2008	
• Canadian Registration Numbers	
• CE PED	
Figure Number Chart.....	4 & 5
Valve ID Tag & Valve Markings Identification	6
THRU CONDUIT SLAB & EXPANDING GATE VALVES.....	7
Thru Conduit Slab Gate Expanded View & Bill of Materials.....	8
Slab Gate Advanced Mechanical Details	9
Thru Conduit Expanding Gate Expanded View & Bill of Materials	10
Expanding Gate Advanced Mechanical Details.....	11
Slab Gate Valve Dimensions 150 Class.....	12
Slab Gate Valve Dimensions 300 Class.....	13
Slab & Expanding Gate Valve Dimensions 600 Class	14
Slab & Expanding Gate Valve Dimensions 900 Class	15
Slab & Expanding Gate Valve Dimensions 1500 Class.....	16
Cv Values	17
Optional Thermal Relief Modifications.....	17
Pressure Temperature Ratings	18, 19, & 20
Flange Dimensions	21 & 22
Butt-welding Dimensions	24 & 25
Industry Standards for Valve Manufacturing	26
Terms and Conditions.....	27

Complete Product Line

Call SCV today @ (281) 482-4728 for all your valve needs or visit us on the web @ www.scvvalve.com.

Carbon & Stainless Bolted Bonnet Gates

Sizes: 2" - 60"
Class: 150 - 2500
Design: API 600



Carbon & Stainless Pressure Seal Gates

Sizes: 2" - 24"
Class: 600 - 2500
Design: API 600



Carbon Steel Thru Conduit Slab & Expanding Gates

Sizes: 2" - 36"
Class: 150 - 1500
Design: API 6D



Carbon & Stainless Bolted Bonnet Globes

Sizes: 2" - 24"
Class: 150 - 2500
Design: BS1873
B16.34



Carbon & Stainless Pressure Seal Globes

Sizes: 2" - 16"
Class: 600 - 2500
Design: BS1873
B16.34



Carbon & Stainless Bolted Cover Checks

Sizes: 2" - 52"
Class: 150 - 2500
Design: BS1868
B16.34



Carbon & Stainless Pressure Seal Checks

Sizes: 2" - 24"
Class: 600 - 2500
Design: API 600
B16.34



Carbon Steel Bolted Cover Piston Checks

Sizes: 1" - 24"
Class: 150 - 2500
Design: API 6D



Dual Plate Checks Wafer & Lug

Wafer Sizes: 1.5" - 84"
Wafer Class: 150 - 2500
Lug Sizes: 2" - 48"
Lug Class: 150 - 900
Design: API 594



Carbon & Stainless Bolted Cover Full Port Swing Checks

Sizes: 2" - 52"
Class: 150 - 2500
Design: API 6D



Carbon & Stainless 2-Piece Floating Balls

Sizes: 1/2" - 12"
Class: 150 - 300
Design: B16.34

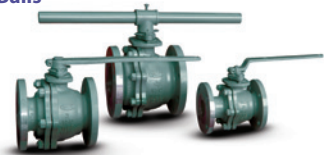

Carbon & Stainless 3-Piece Trunnion Balls

Sizes: 2-1/16" - 13-5/8"
Pressure: 2000, 3000 & 5000
Design: API 6A

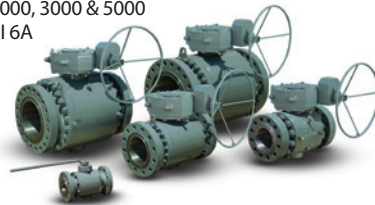

Carbon & Stainless 3-Piece Trunnion Balls Bolted & Welded Body

Sizes: 2" - 48"
Class: 150 - 2500
Design: API 6D



Sub-Sea 3-Piece & Top Entry Trunnion Balls Bolted & Welded Body

Sizes: 2" - 24"
Class: 150 - 2500
Design: API 6D
API 6DSS



Carbon & Stainless Double Block & Bleed Trunnion Balls

Sizes: 2" - 24"
Class: 150 - 2500



Carbon & Stainless 3-Piece Full Port Balls

Sizes: 1/4" - 3"
Class: 3705 W.O.G.
Design: B16.34



Forged Steel Gates

Sizes: 3/8" - 2"
Class: 800 - 2500
Design: API 602



Forged Steel Globes

Sizes: 3/8" - 2"
Class: 800 - 2500
Design: API 602



Forged Steel Swing Checks

Sizes: 3/8" - 2"
Class: 800 - 2500
Design: API 602



Forged Steel Piston Checks

Sizes: 3/8" - 2"
Class: 800 - 2500
Design: API 602



Carbon Steel Dual Seal Expanding Plugs

Sizes: 2" - 24"
Class: 150 - 900
Design: API 6D



Carbon Steel Lubricated Plugs

Sizes: 1/2" - 36"
Class: 150 - 2500
Design: API 6D



Carbon & Stainless Rising Stem Balls

Sizes: 2" - 24"
Class: 150 - 1500
Design: API 6D



Certifications & Registrations

American Petroleum Institute (API)



API 6A



API 6D

International Organization for Standardization (ISO)



ISO 9001:2008 Certificate

Canadian Registration Number

- CRN# OC7063.2 - Alberta
- CRN# OC07063.24 - Manitoba
- CRN# OC07063.25 - Ontario

European Conformance Pressure Equipment Directive



CE PED Certificate

(Modified for display purposes. Actual certificates available on our web site (www.scvalve.com).

SCV Figure Number Chart

Note: SCV Figure Chart is subject to change without notice.

1

2

3

4

5

6

Valve Type	Bore Size	Pressure Class	Body/Bonnet	Body Material	Trim Material
BAL = Ball	.02 = 1/16"	.5 = 50	B = Bolted	01 = Cast Iron	10 = CR13
DBV = Double Ball Valve	.03 = 1/8"	.7 = 75	L = Lug	02 = A352/LCC	11 = CR13/HF
DCK = Dual Wafer Check	.25 = 1/4"	01 = 150	N = NRS Bolted	03 = A352/LC2	12 = CR13 HF/HF
DSP = Dual Seal Plug	.50 = 1/2"	02 = 200	P = Pressure Seal	04 = CF8	13 = A105/ENP
FCK = Full Port Check	.07 = 9/16"	03 = 300	S = Seal Weld	05 = Ductile	14 = Steel/Chrome
GAT = Gate	.08 = 13/16"	04 = 400	T = Top Entry	06 = CF8M	15 = LF2/ENP
GLB = Globe	.75 = 3/4"	06 = 600	U = Union	08 = A216 WCC	16 = 416
PCK = Piston Check	01 = 1"	08 = 800	W = Wafer	09 = WC9/F22	17 = 17 4-PH
PLG = Plug	1.2 = 1-1/16"	09 = 900	Y = Y-Pattern	10 = A216 WCB	20 = Alloy 20
RSB = Rising Stem Ball	1.3 = 1-1/8"	12 = 125		11 = A352 LCB	21 = Alloy 20/HF
SCK = Swing Check	1.4 = 1-1/4"	15 = 1500		12 = A350 LF2	22 = F-22
TCG = Thru Conduit Gate	1.5 = 1-1/2"	17 = 175		13 = A105	25 = Inconel Overlay
TCK = Tilting Disc Check	1.8 = 1-13/16"	20 = 2000		14 = LC3/LF3	28 = Sanicro 28
WCK = Wafer Check	02 = 2"	25 = 2500		15 = A217 C5	30 = 4130
	2.2 = 2-1/16"	30 = 3000		16 = WC6/F11	31 = 321
	2.3 = 2-1/8"	45 = 4500		17 = 17-4 PH	32 = 316L
	2.5 = 2-1/2"	50 = 5000		18 = LF6	33 = 304/HF
	2.7 = 2-9/16"	60 = 6000		19 = LF4	34 = 304
	03 = 3"	10 = 10000		20 = Alloy 20	35 = 316/HF
	3.3 = 3-16"	05 = 15000		22 = F-22	36 = 316
	04 = 4"	37 = 3705		24 = 254 SMO	37 = 317/HF
	4.2 = 4-1/16"			25 = F5	38 = 317
	05 = 05"			26 = F91	39 = 1040
	06 = 06"			27 = C12A	41 = 410/F6a
	08 = 08"			28 = Sanicro 28	42 = Full Teflon
	10 = 10"			29 = C12/F9	44 = F44 Duplex
	12 = 12"			30 = AISI 4130	47 = 347
	14 = 14"			31 = 321	48 = 347/HF
	16 = 16"			32 = 321L	49 = Carpenter
	18 = 18"			33 = 304L	50 = Monel
	20 = 20"			34 = 304	51 = F51 Duplex
	22 = 22"			35 = 316L	52 = Nickel Alloy
	24 = 24"			36 = 316	53 = F53 Duplex
	26 = 26"			37 = 317L	54 = A516/ENP
	30 = 30"			38 = 317	55 = F55 Duplex
	32 = 32"			40 = AISI 4140	56 = A36/ENP
	36 = 36"			41 = 410/F6a	57 = A537/ENP
	40 = 40"			44 = F44 Duplex	60 = Duplex
	42 = 42"			47 = 347	61 = Super Duplex
	48 = 48"			48 = 347L	62 = Inconel 625
	50 = 50"			49 = Carpenter	63 = Inconel 600
	54 = 54"			50 = Monel	69 = Naval Brass
	60 = 60"			51 = F51 Duplex	70 = Bronze
	72 = 72"			52 = Nickel Alloy	71 = Aluminum
	78 = 78"			53 = F53 Duplex	78 = Inconel 718
	72 = 72"			54 = ASTM A516	80 = Alu/Brz
	78 = 78"			55 = F55 Duplex	81 = Ni Alu/Brz
				56 = ASTM A36	82 = Inconel 825
				57 = ASTM A537	83 = Hastelloy
				60 = Duplex	86 = 8026
				61 = Super Duplex	87 = 487
				62 = Inconel 625	90 = Titanium
				63 = Inconel 600	91 = Tantalum
				65 = F65	92 = Inconel 925
				69 = Naval Brass	93 = Tungsten Carbide
				70 = Bronze	96 = Zirconium
				71 = Aluminum	97 = Nickel Boron
				78 = Inconel 718	
				80 = Alu Bronze	
				81 = Ni Alu/Brz	
				82 = Inconel 825	
				83 = Hastelloy B	
				84 = Hastelloy C	
				86 = AISI 8026	
				87 = 487	
				90 = Titanium	
				91 = Tantalum	
				96 = Zirconium	

7

8

9

10

11

12

Ends	Operation	Configuration	Seal Material	Seat Material	Special
C = Clamp	B = Bare Stem	32 = 3 Way 2 Port	4 = 304 Ring	D = Devlon	By Pass
F = Flat	D = Dual Acting	3F = 3 Way Floater	6 = 316 Ring	G = Graphite	Cadium Coat
H = Hub	E = Electric	3T = 3 Way Trunnion	B = Buna	K = PCTFE	Cryogenic
J = RTJ	G = Gear	43 = 4 Way 3 Port	E = EPDM	M = Metal Seated	Epoxy Paint
N = Nipples	H = Handwheel	4F = 4 Way Floater	F = Fluorosilicone	N = Nylon	Lip Seal
M = SW x TH	L = Lever	4T = 4 Way Trunnion	G = Grafoil	O = Nova	Metal Hardface
O = ODD	O = Oil/Gas	EX = Expanding	H = HNBR	P = PEEK	Metal Tungsten Carbide
R = RF	S = S/Return	FF = Full Floater	K = Kalrez	R = RPTFE	Nitride
S = SW	Y = Hydraulic	FT = Full Trunnion	N = Neoprene	T = Teflon	Outside WT
T = TH		RF = Red, Floater	P = Polyuerethane		QPQ Inturnal
W = WE		RT = Red, Trunnion	R = NBR		Slam Retard
A = RF x BW		SJ = Steam Jacket	S = Silicone		Stancoat
B = RTJ x BW			T = Teflon		Sub Sea
			U = Floursint		Teflon Lined
			V = Viton		Top Extension
					Zinc Base

Figure Number Profile

1	2	3	4	5	6	7	8	9	10	11	12
BAL	02	01	B	13	13	R	L	FT	-	HD	X

No.	Figure Number Code	Description
1	Valve Type	Identifies the valve body design (gate, globe, ball, plug, etc.)
2	Bore Size	Identifies nominal port size (1/4" to 78")
3	Pressure Class	Identifies pressure classes ranging from 50 to 15,000
4	Body/Bonnet	Identifies body and bonnet material configuration (bolted bonnet, pressure seal, top entry, etc.)
5	Body Material	Identifies body material composition (A105, WCB, Stainless Steel, F51, etc.)
6	Trim Material	Identifies trim material composition (ENP, 316, F6, Cr13, HF, etc.)
7	Ends	Identifies end connection configuration (weld end, RTJ, socket weld, hub, etc.)
8	Operation	Identifies valve operation mechanism (electric, gear, hydraulic, lever, etc.)
9	Configuration (ball & expanding gate only)	Identifies valve configuration (floater, trunnion, etc.)
10	Seal Material	Identifies seal material composition (Buna, EPDM, Grafoil, HNBR, Neoprene, Teflon, etc.)
11	Seat Material	Identifies seat material composition (Devlon, Graphite, PCTFE, Nylon, PEEK, Teflon, etc.)
12	Special	Identifies special treatments or configurations (when applicable)

Sample Figure Numbers & Descriptions

Valve Type	Sample Figure #	Description
Trunnion Ball	BAL0201B1313RLFT-HD	Ball Valve, 2", 150#, Bolted Bonnet, A105 Body, ENP Trim, HNBR Seals, Devlon Seats, Raised Face, Lever Operated, Full Port, Trunnion Mtd.
Floating Ball	BAL0201B1036RLFF-/T	Ball Valve, 2", 150#, Bolted Bonnet, A216 WCB Body, 316SS Trim, PTFE Seats, Raised Face, Lever Oper., Full Port, Floating Ball
Dual Plate Wafer Check	DKK0406W1035R	Dual Plate Wafer Check, 4", 600#, Wafer Style, A216 WCB Body, 316SS/HF Trim, Raised Face
Full Port Swing Check	FCR0409B1011J	Full Port Swing Check, 4", 900#, Bolted Bonnet, A216 WCB Body, Cr13/HF Trim, Ring Type Joint
Wedge Gate	GAT0303P1035RH	Wedge Gate, 3", 300#, Pressure Seal, WCB, 316SS/HF Trim, Raised Face, Hand Wheel Operated
Globe	GLB0803B1011RH	Globe, 8", 300#, Bolted Bonnet, WCB, Cr13/HF Trim, Raised Face, Hand Wheel Operated
Swing Check	SCK0601B1036R	Swing Check, 6", 150#, Bolted Bonnet, WCB, Cr13/HF Trim, Raised Face
Lubricated Plug	PLG0803B1041RL-VM	Lubricated Plug Valve, 8", 300#, Bolted Bonnet, WCB, 410SS Trim, Viton Seals, Hardface Seats, Raised Face, Lever Operated
Dual Seal Plug	DSP0803B1011RG	Dual Seal Plug, 8", 300#, bolted Bonnet, WCB, Cr13/HF Trim, Raised Face, Gear Operated
Thru Conduit Gate	TCG0603B1036RG-VM	Thru Conduit Gate, 6", 300#, Bolted Bonnet, WCB, 316SS Trim, Viton Seals, Hardface Seats, Raised Face, Gear Operated
Expanding Gate	TCG0603B1036RGEX-VM	Thru Conduit Gate, 6", 300#, Bolted Bonnet, WCB, 316SS Trim, Viton Seals, Hardface Seats, Raised Face, Gear Operated, Expanding
Rising Stem Ball	RSB1006B1036RG-/R	Rising Stem Ball, 10", 600#, Bolted Bonnet, WCB Body, 316SS Trim, RPTFE Seats, Raised Face, Gear Operated

Note: Wedge Gates, Globes, Swing Checks, Piston Checks, Wafer Checks are metal-to-metal seats as standard.

Valve ID Tag & Valve Markings Identification

Valve ID Tag

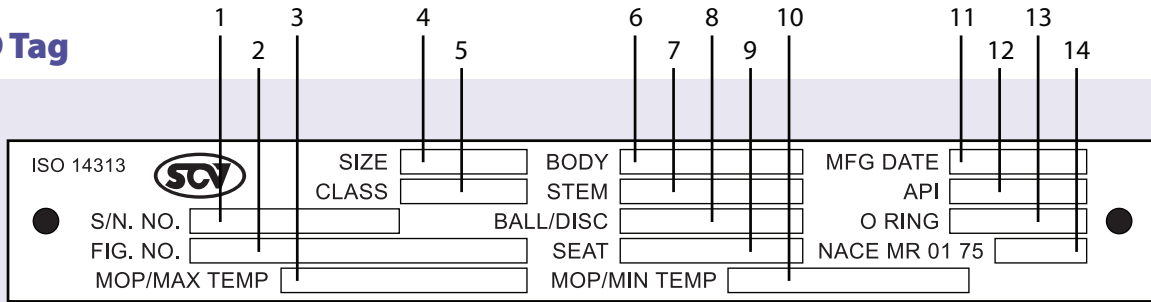

No.	Figure Number Code	Description
1	Serial Number	Identifies certified manufacturers serial number
2	Figure Number	Identifies the detailed valve configuration (valve type, bore size, pressure class, materials, etc.)
3	MOP/Max. Temp.	Identifies the maximum operating pressure in PSI and maximum operating temperature in Fahrenheit
4	Size	Identifies bore size
5	Pressure Class	Identifies pressure classifications per API requirements
6	Body Material	Identifies body metal material composition (A105, WCB, F51, CF8M, etc.)
7	Stem Material	Identifies stem material composition (A105, 410SS, 17-4pH, etc.)
8	Ball/Disc Material	Identifies ball/disc material composition (A105, 316SS, ENP, etc.)
9	Seat Material	Identifies seat material composition (PEEK, Teflon, Nylon, etc.)
10	API Conformance	Identifies API conformance (600, 6D, 6A, etc.)
11	Manufacturing Date	Identifies the date the valve manufacturing completion date
12	MOP/Min. Temp.	Identifies the maximum operating pressure in PSI and minimum operating temperature in Fahrenheit
13	O Ring	Identifies the O Ring material composition (Viton, Viton GLT, etc.)
14	NACE MR 01 75	Identifies corrosion resistance

Valve Markings

No.	Valve ID Components
1	Tag
2	Brand
3	Size
4	Pressure Class
5	Body Material
6	Heat Number

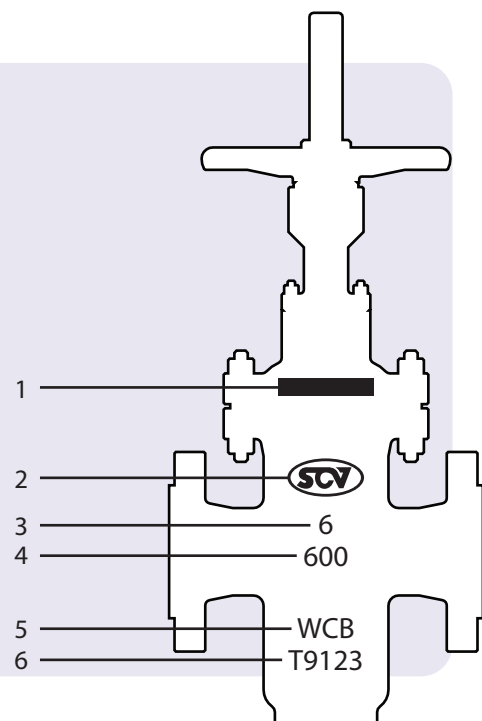

Note: SCV reserves the right to modify our products for improvement without prior notice.



Southern California Valve

Thru Conduit Slab & Expanding Gate Valves

Class: 150 - 1500/Sizes: 2" - 36"



Design and Manufacturing Standards	
Basic Design	API 6D
Face to Face Dimension	ANSI B16.10
Flange End Dimension	ANSI/ASME B16.5 (2" to 24") ANSI/ASME B16.47 & MSS SP-44 (26" & up)
Butt-Weld End Dimension	ANSI/ASME B16.25
Inspection & Testing	API 6D



Thru Conduit Slab Gate Valve

Our backseat design is now metal-to-metal.

[Expanded View & Bill of Materials]

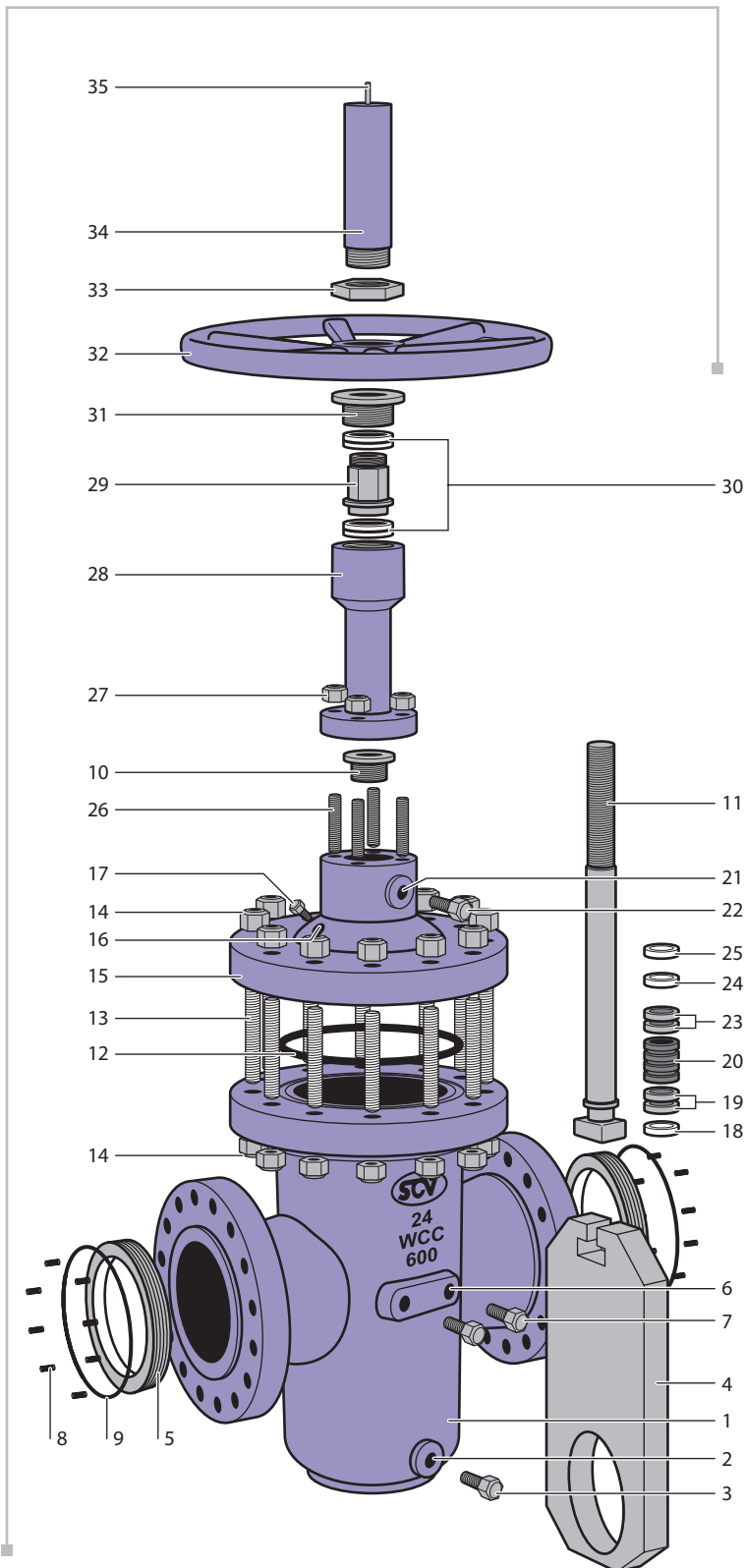

Bill of Materials		
No.	Part	Material
1	Body	ASTM A216 WCC
2	Body Drain Port	/
3	Body Drain Plug	4140
4	Slab Disc	ASTM 515 Gr 70
5	Seat	ASTM A105+ENP
6	Sealant Injector Port	/
7	Sealant Injector Fitting	4140
8	Seat Spring	Inconel x-750
9	Seat O-Ring	Viton
10	Back Seat	Metal-to-Metal
11	Stem	ASTM 4130 + ENP
12	Bonnet Gasket	304 SS + Graphite
13	Stud Bolt	ASTM A193 B7M
14	Nut	ASTM A194 2HM
15	Bonnet	ASTM A216 WCC
16	Bonnet Vent Port	/
17	Bonnet Vent Plug	4140
18	Packing Seat	1025
19	Packing Rings	PTFE
20	Lantern Ring	304
21	Packing Injector Port	/
22	Packing Injector Fitting	4140
23	Packing Rings	PTFE
24	UP Packing	1025
25	Graphite Packing	Graphite
26	Stud Bolt	ASTM A193 B7M
27	Nut	ASTM A194 2HM
28	Yoke	ASTM A216 WCC
29	Stem Nut	Bronze
30	Bearings	Steel
31	Stem Nut Retainer	1025
32	Handwheel	Steel
33	Handwheel Nut	Steel
34	Stem Protector	Steel
35	Stem Indicator	Stainless Steel

Slab Gate Advanced Mechanical Details

Through its simple design and efficient performance, the slab gate's two spring loaded floating seats are pressure energized. This allows for complete sealing, both upstream and downstream.

[Features Overview]

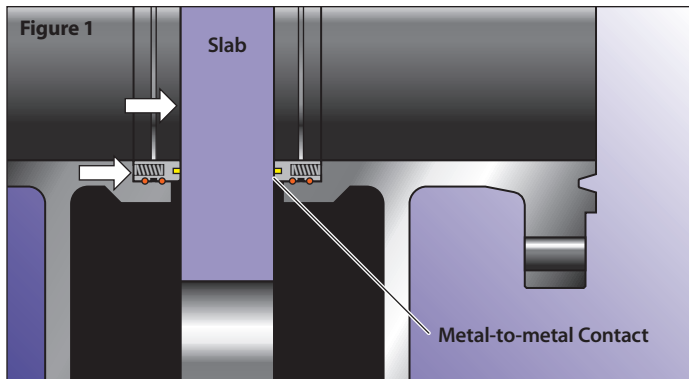

Seats – Soft & Metal

The spring loaded double O-ring design seats maintain a perfect seal with the gate in both low and high pressure applications. The soft seat inserts help to ensure that the primary sealing occurs at the gate. In the event of soft seat damage, the seating of metal to metal will function as a secondary seal. **(Figure 1)**

Double Block

When the valve is in the closed position and also has equal or no pressure, both spring loaded seats can shut off line pressure independently of upstream and downstream pressure. This creates a double block scenario. **(Figure 2)**

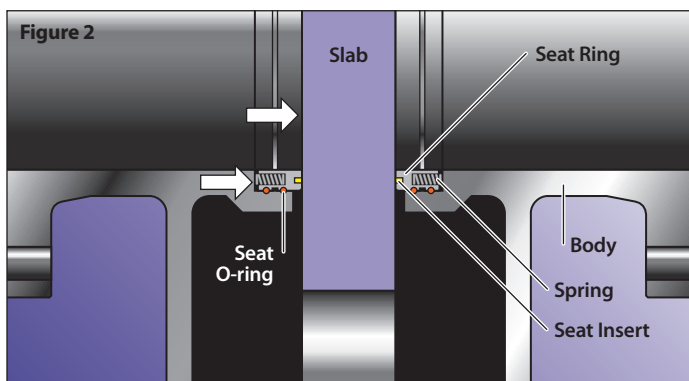

When line pressure is applied, the pressure forces the slab gate to float against the downstream seat and form a tight seal. At the same time, the upstream line pressure forces the upstream seat on the slab gate to form an upstream seal. **(Figure 3)**

Self Relieving Cavity

The double block and bleed slab gate design, in the closed position, may experience an increase in cavity pressure due to thermal expansion. When the cavity pressure exceeds the line pressure, the seat is forced away from the gate surface allowing the excess cavity pressure to be vented into the line. This allows for a pressure balance between the body cavity and the line. **(Figure 4)**

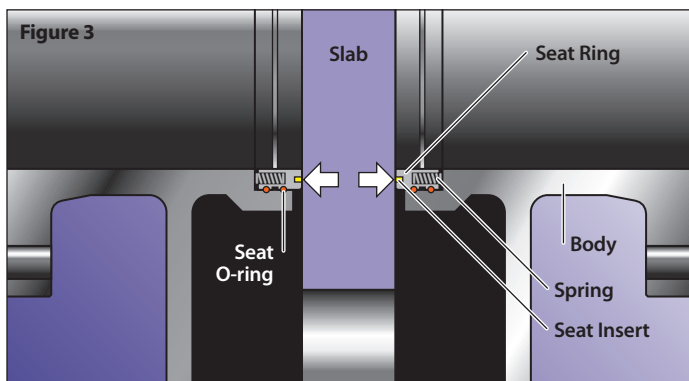

Secondary Sealant Injection System

Valves 6" and larger will have secondary sealant injection fittings for the stem and seats. If the seat inserts or stem O-rings become damaged, leakage from the seat and stem can be prevented by injecting sealant into the fittings. **(Figure 5)**

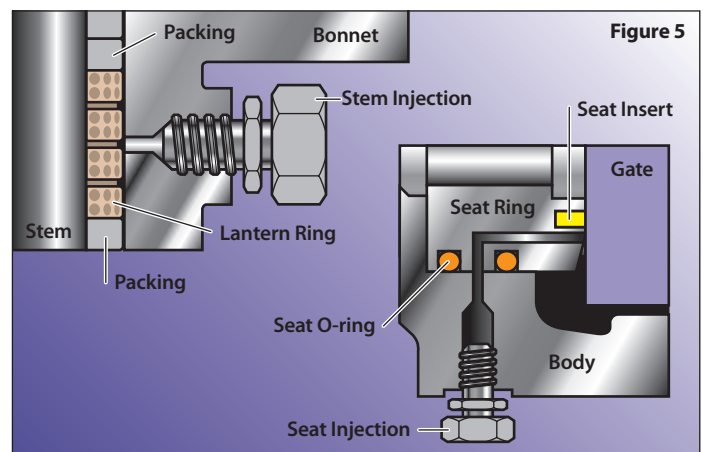
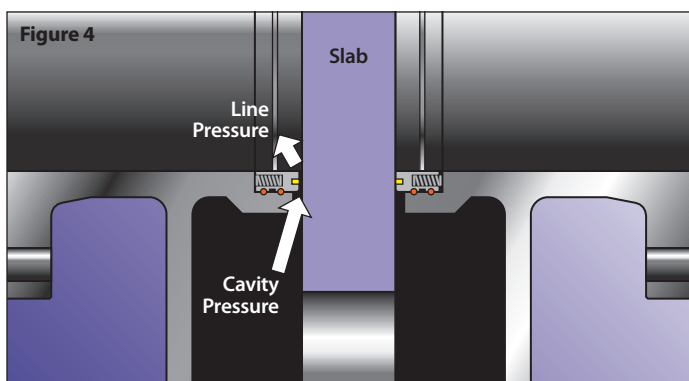

Thru Conduit Expanding Gate Valve

Our backseat design is now metal-to-metal.

[Expanded View & Bill of Materials]

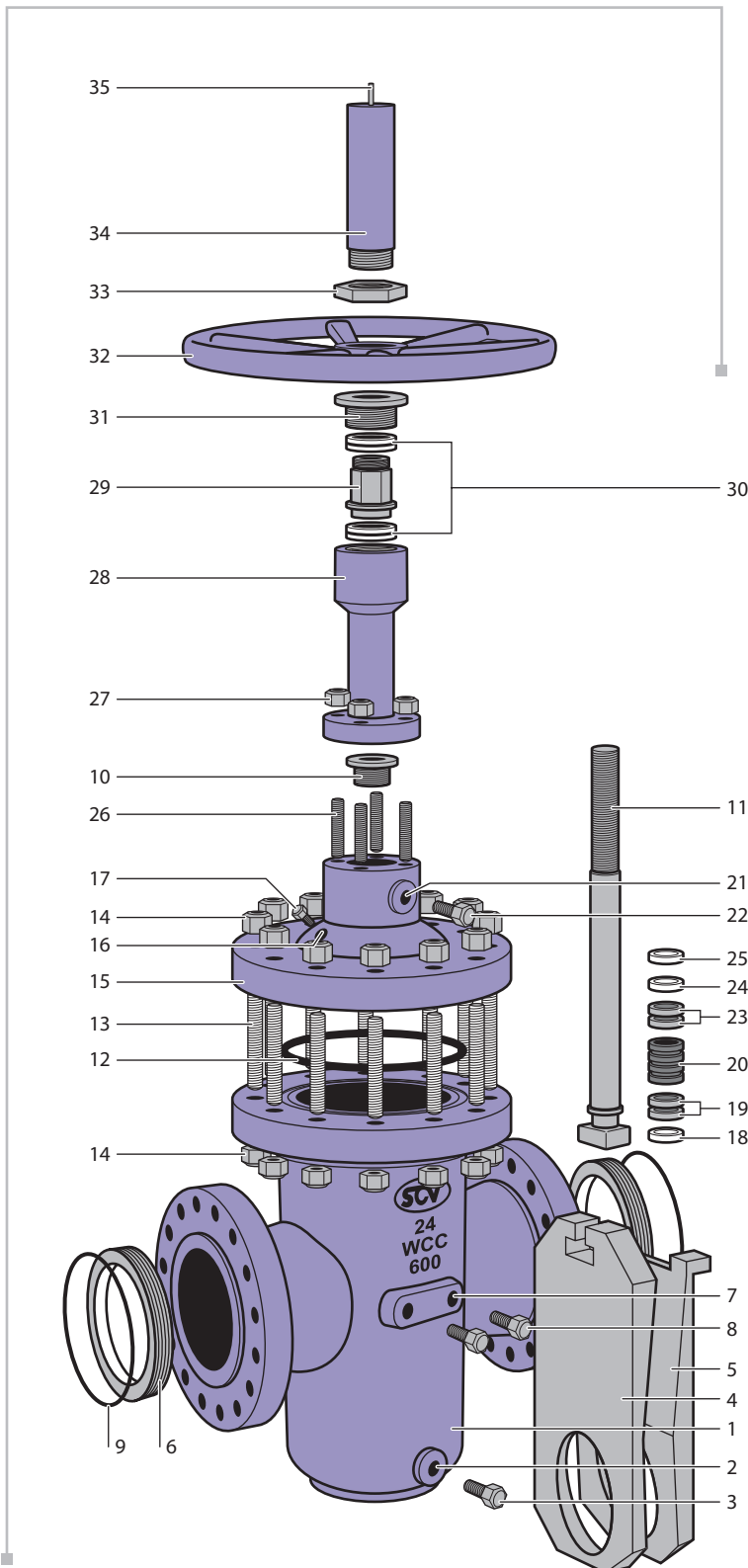

Bill of Materials		
No.	Part	Material
1	Body	ASTM A216 WCC
2	Body Drain Port	/
3	Body Drain Plug	4140
4	Expanding Disc Gate	ASTM 515 Gr 70
5	Expanding Disc Segment	ASTM A105+ENP
6	Seat	/
7	Sealant Injector Port	4140
8	Sealant Injector Fitting	Inconel x-750
9	O-Ring	Viton
10	Back Seat	Metal-to-Metal
11	Stem	ASTM 4130 + ENP
12	Bonnet Gasket	304 SS + Graphite
13	Stud Bolt	ASTM A193 B7M
14	Nut	ASTM A194 2HM
15	Bonnet	ASTM A216 WCC
16	Bonnet Vent Port	/
17	Bonnet Vent Plug	4140
18	Packing Seat	1025
19	Packing Rings	PTFE
20	Lantern Ring	304
21	Packing Injector Port	/
22	Packing Injector Fitting	4140
23	Packing Rings	PTFE
24	UP Packing	1025
25	Graphite Packing	Graphite
26	Stud Bolt	ASTM A193 B7M
27	Nut	ASTM A194 2HM
28	Yoke	ASTM A216 WCC
29	Stem Nut	Bronze
30	Bearings	Steel
31	Stem Nut Retainer	1025
32	Handwheel	Steel
33	Handwheel Nut	Steel
34	Stem Protector	Steel
35	Stem Indicator	Stainless Steel

Expanding Gate Advanced Mechanical Details

The SCV Expanding Gate valve design provides a mechanical seal between the seats and the gate in both high and low pressure applications. The expanding gate valve does not require line pressure to seal and is recommended when a tight mechanical seal is required.

[Features Overview]

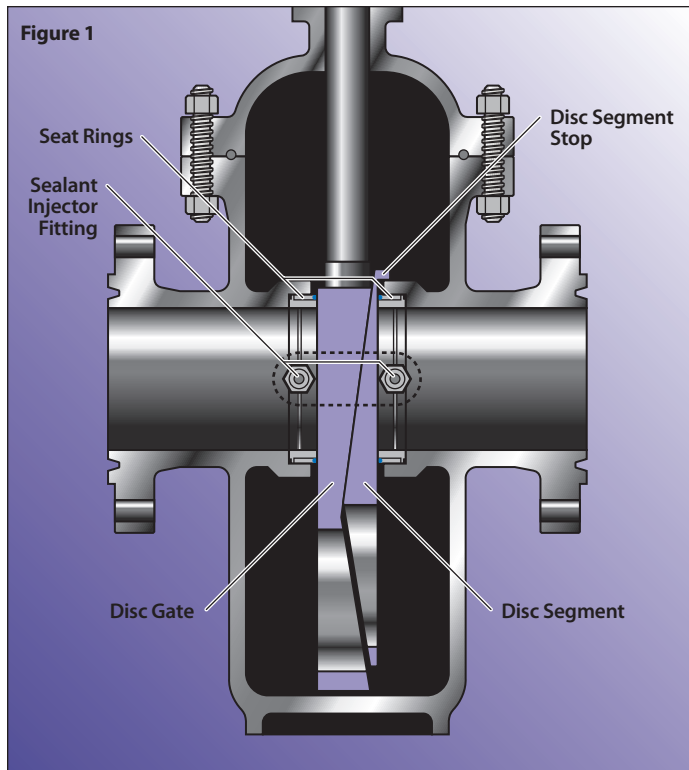

Full Expanded Closed

In the full expanded closed position, the segment stop has engaged with the lower body stop and the gate is wedged downward, expanding the gate and segment to form a tight seal against the upstream and downstream seats. Body cavity venting will assist to provide tight shut off. **(Figure 1)**

Mid Position

When operating towards the open position, the gate travels across the wedge angle of the segment. This retracts the assembly so that it will slide freely between the seat faces. **(Figure 2)**

Full Expanded Open

In the full expanded open position, the segment stop has engaged the upper body stop and the gate is wedged upward. This expands the segment and the gate into the seats, isolating the flow from the cavity. **(Figure 3)**

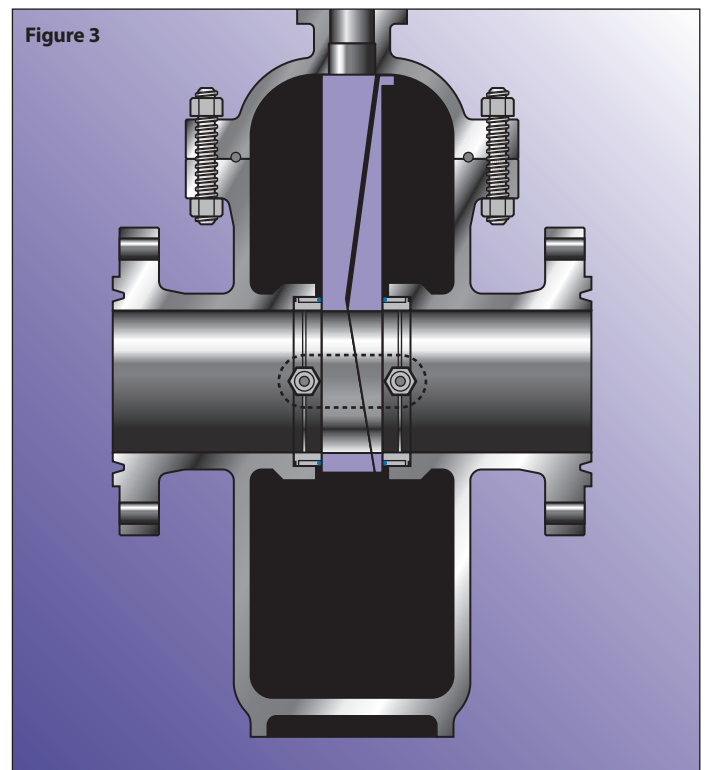
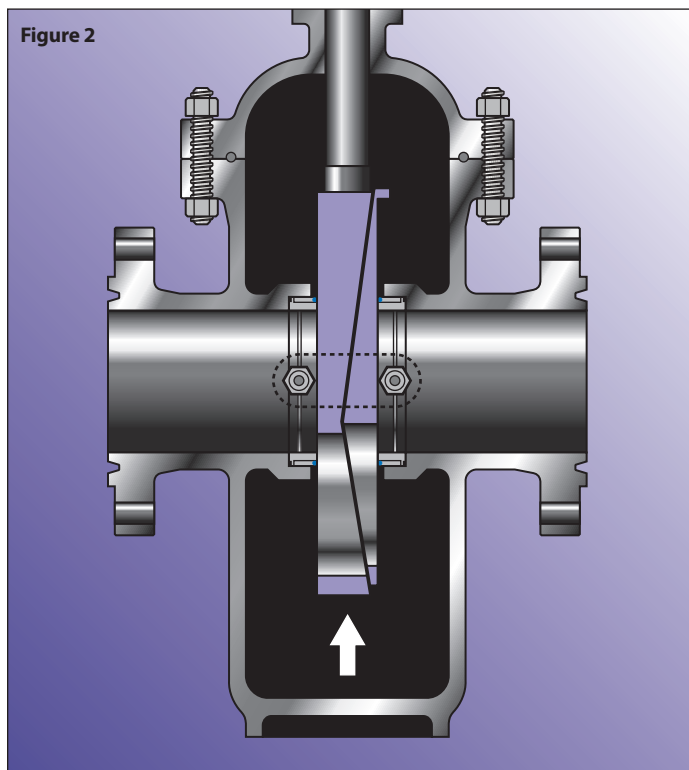

Slab Gate Valve Dimensions

Size: 2" - 36"

Class: 150

Expanding gate valve dimensions are upon request.

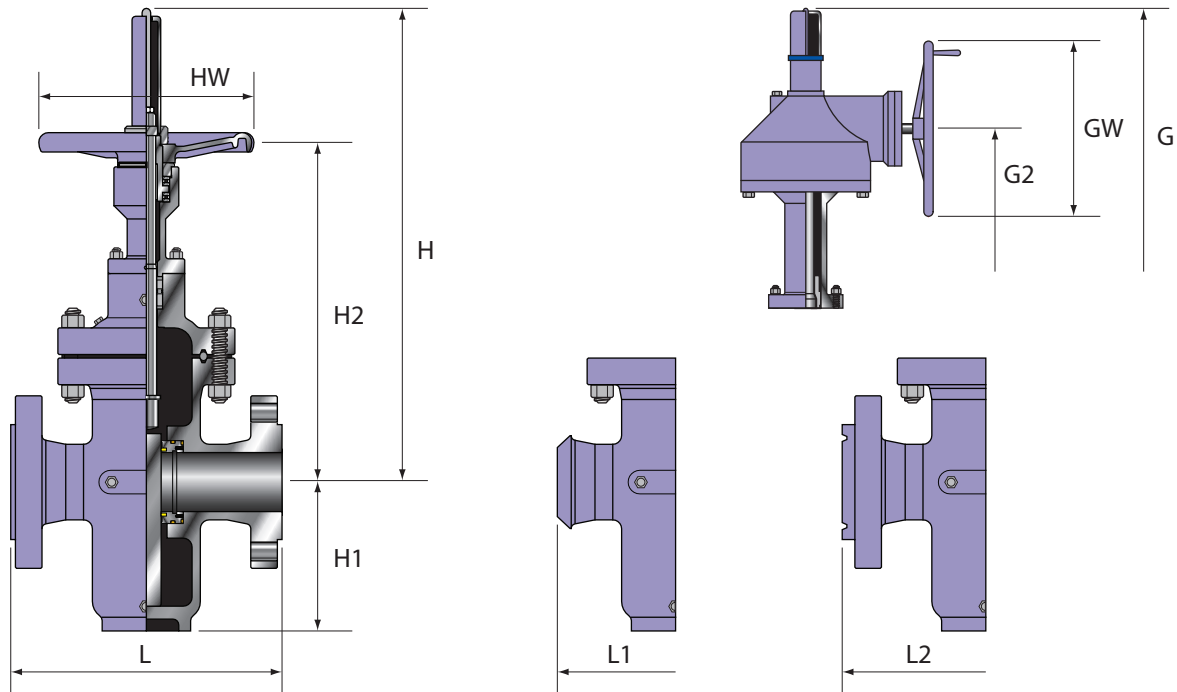

CLASS 150	SIZE		END-TO-END			CENTER-TO-BOTTOM		HANDWHEEL OPERATED			GEAR OPERATED			WEIGHTS LBS/KG
	IN	MM	RF - L	BW - L1	RTJ - L2	H1	H	H2	HW	G	G2	GW		
	2	50	7	8.5	7.5	4.80	17.72	12.40	9.84	/	/	/	75	
	2.5	65	7.5	9.5	8	6.06	21.65	16.54	11.81	/	/	/	90	
	3	80	8	11.12	8.5	6.65	24.02	16.85	11.81	/	/	/	123	
	4	100	9	12	9.5	7.60	27.56	19.45	11.81	30.31	25.59	12.20	185	
	6	150	10.5	15.88	11	11.14	35.24	24.61	13.78	37.99	31.50	12.20	313	
	8	200	11.5	16.5	12	13.86	44.49	30.87	13.78	47.24	37.80	12.20	520	
	10	250	13	18	13.5	17.32	50.79	36.87	15.75	53.54	42.52	12.20	776	
	12	300	14	19.75	14.5	20.27	58.27	42.52	17.72	61.42	47.24	12.20	992	
	14	350	15	22.5	15.5	23.70	64.59	50.51	19.69	68.50	53.15	18.11	1323	
	16	400	16	24	16.5	26.69	72.83	55.79	19.69	75.98	59.06	18.11	1623	
	18	450	17	26	17.5	30.91	81.89	58.62	23.62	85.04	66.14	18.11	1962	
	20	500	18	28	18.5	33.66	90.55	65.83	27.56	95.28	72.83	18.11	2469	
	24	600	20	32	20.5	41.14	105.51	79.21	31.50	110.24	83.46	18.11	4431	
	30	750	24	36	/	53.15	137.44	100.39	39.37	143.31	110.24	18.11	6438	
	36	900	28	40	/	59.45	153.43	112.20	39.37	159.45	121.26	23.62	11839	

Slab Gate Valve Dimensions

Size: 2" - 36"

Class: 300

Expanding gate valve dimensions are upon request.

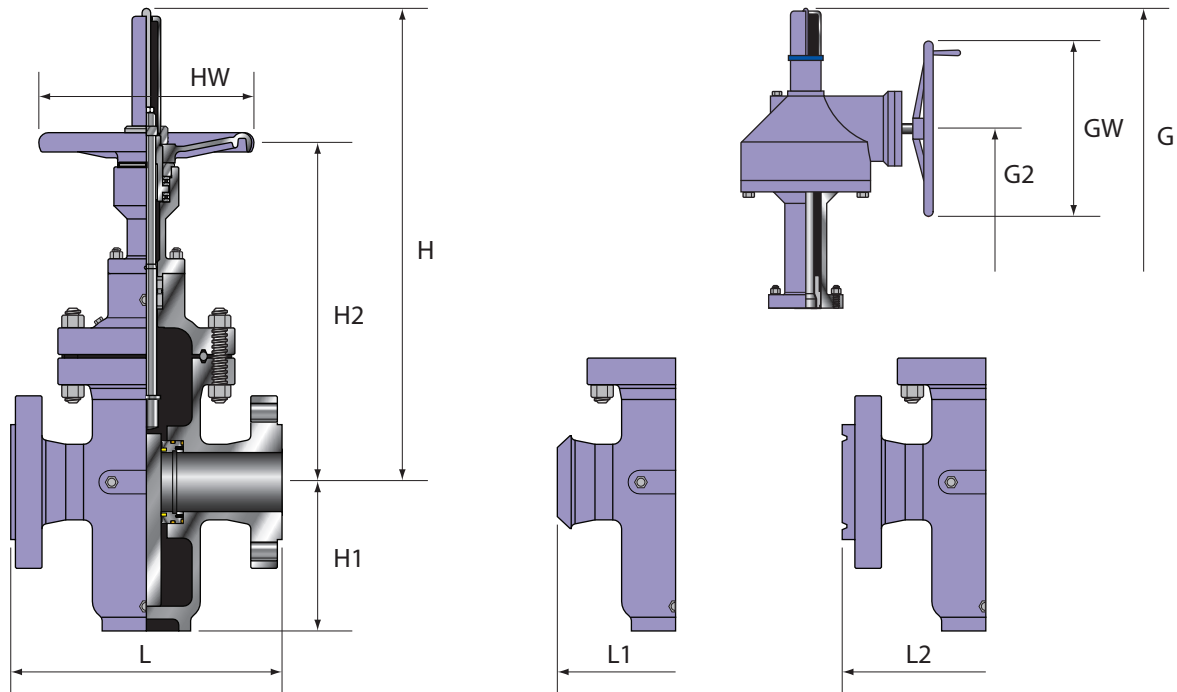

CLASS 300	SIZE		END-TO-END			CENTER-TO-BOTTOM		HANDWHEEL OPERATED			GEAR OPERATED			WEIGHTS LBS/KG
	IN	MM	RF - L	BW - L1	RTJ - L2	H1	H	H2	HW	G	G2	GW		
	2	50	8.5	8.5	9.12	5.93	18.03	12.80	9.84	/	/	/	119	
	2.5	65	9.5	9.5	10.12	6.65	21.85	16.54	11.81	/	/	/	150	
	3	80	11.12	11.12	11.74	7.24	24.21	16.93	11.81	/	/	/	187	
	4	100	12	12	12.62	8.58	27.95	19.69	11.81	30.31	25.59	12.20	247	
	6	150	15.88	15.88	16.5	12.24	34.43	24.61	13.78	37.99	31.50	12.20	529	
	8	200	16.5	16.5	17.12	15.04	44.68	31.10	13.78	47.24	37.80	12.20	805	
	10	250	18	18	18.62	18.74	55.16	40.94	15.75	53.54	42.91	12.20	1102	
	12	300	19.75	19.75	20.37	21.46	62.20	45.28	15.75	61.42	47.24	12.20	1669	
	14	350	30	30	30.62	25.39	/	/	/	68.50	53.15	18.11	2315	
	16	400	33	33	33.62	28.66	/	/	/	75.98	60.63	18.11	3263	
	18	450	36	36	36.62	31.50	/	/	/	85.04	66.93	18.11	4497	
	20	500	39	39	39.75	36.61	/	/	/	95.28	72.83	18.11	5942	
	24	600	45	45	45.88	43.31	/	/	/	110.24	83.46	18.11	9392	
	30	750	55	55	56	55.91	/	/	/	143.31	110.24	18.11	13889	
	36	900	68	68	69.12	59.45	/	/	/	159.45	121.26	23.32	19621	

Slab & Expanding Gate Valve Dimensions

Size: 2" - 36"
Class: 600

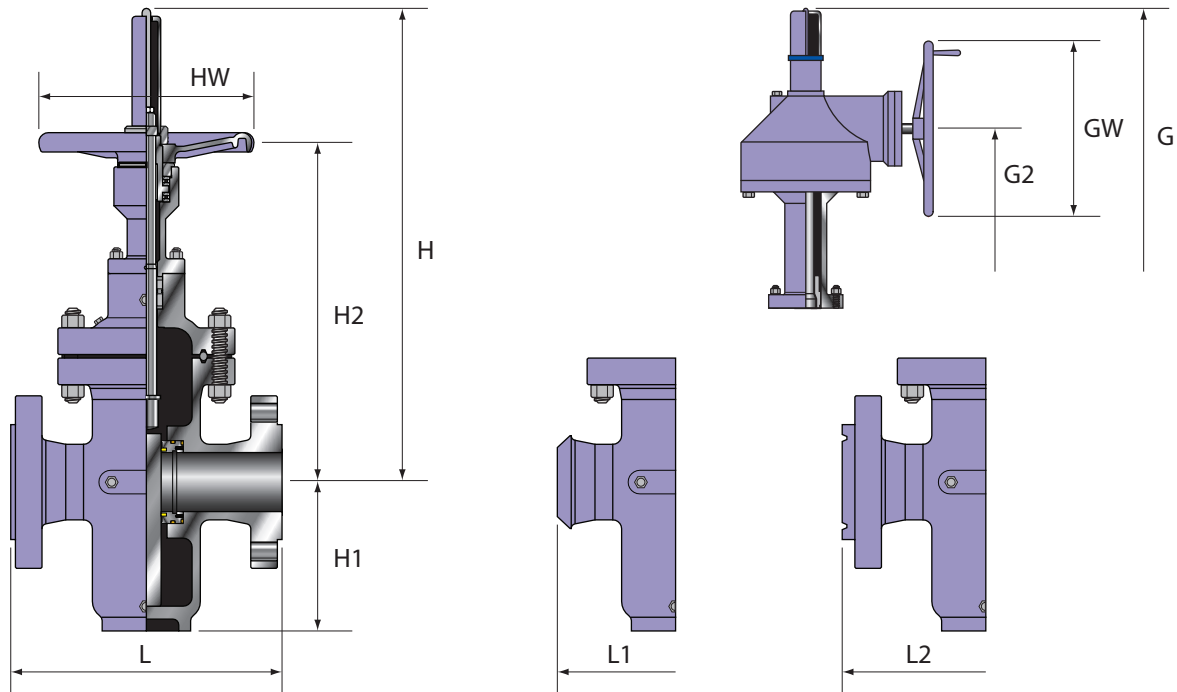

CLASS 600	SIZE		END-TO-END			CENTER-TO-BOTTOM	HANDWHEEL OPERATED			GEAR OPERATED			WEIGHTS
	IN	MM	RF - L	BW - L1	RTJ - L2	H1	H	H2	HW	G	G2	GW	LBS/KG
	2	50	11.3	11.3	11.62	6.22	18.43	13.19	11.81	19.88	16.93	12.20	146
	2.5	65	13	13	13.12	7.48	22.24	16.93	11.81	22.05	18.50	12.20	205
	3	80	14	14	14.12	8.86	24.61	17.32	13.78	24.02	20.09	12.20	243
	4	100	17	17	17.12	10.14	28.35	20.08	13.78	30.31	25.59	12.20	344
	6	150	22	22	22.12	12.99	35.83	24.80	15.75	37.99	31.50	12.20	635
	8	200	26	26	26.12	16.14	45.08	31.50	19.69	47.24	37.80	12.20	1411
	10	250	31	31	31.12	19.29	55.55	41.34	19.69	53.94	42.91	18.11	1984
	12	300	33	33	33.12	22.44	62.60	45.67	23.62	61.42	47.24	18.11	2502
	14	350	35	35	35.12	25.59	/	/	/	68.50	53.15	18.11	3748
	16	400	39	39	39.12	28.94	/	/	/	77.56	60.63	18.11	5181
	18	450	43	43	43.12	31.89	/	/	/	88.98	66.93	18.11	6120
	20	500	47	47	47.25	35.63	/	/	/	95.28	72.83	18.11	9281
	24	600	55	55	55.38	45.67	/	/	/	101.97	79.53	18.11	13250
	30	750	65	65	65.5	51	/	/	/	150	104	24	17439
	36	900	82	82	85.62	60	/	/	/	173	121	24	33510
			2083	2083	2175	1530	/	/	/	4400	3070	600	15200

Slab & Expanding Gate Valve Dimensions

Size: 2" - 24"
Class: 900

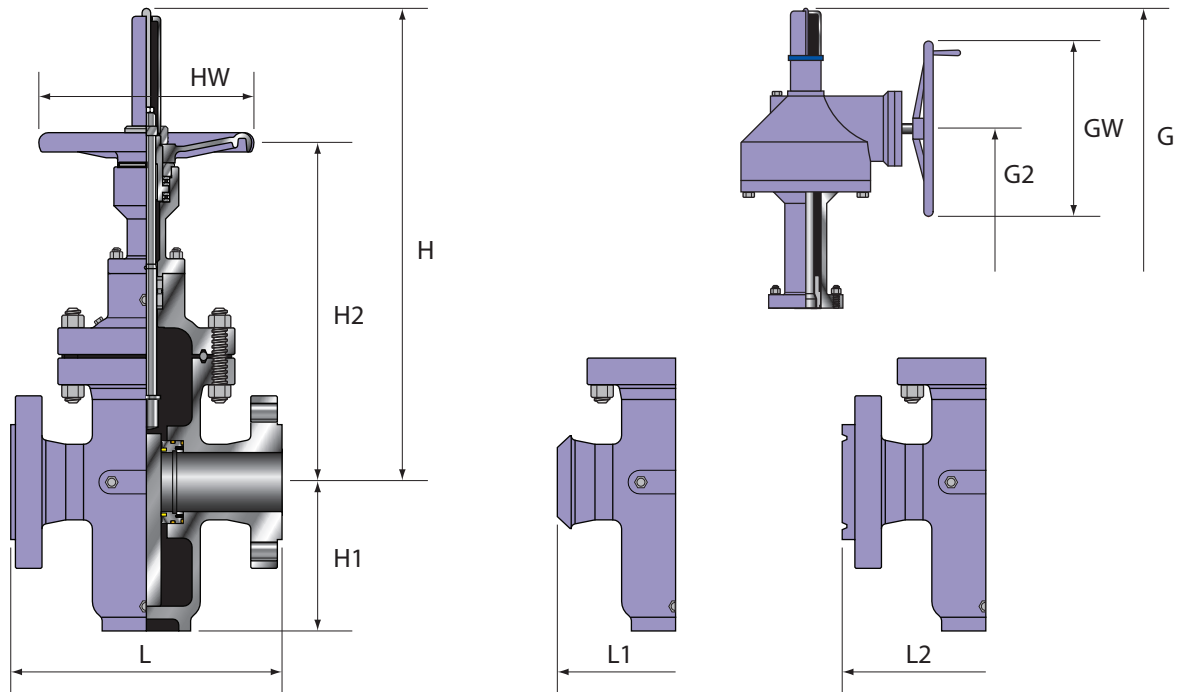

CLASS 900	SIZE		END-TO-END			CENTER-TO-BOTTOM		HANDWHEEL OPERATED				GEAR OPERATED			WEIGHTS LBS/KG
	IN	MM	RF - L	BW - L1	RTJ - L2	H1	H	H2	HW	G	G2	GW			
	2	50	14.5	14.5	14.62	6.22	18.62	13.19	11.81	20.67	17.72	12.20	227		
	2.5	65	16.5	16.5	16.62	7.48	22.44	17.13	11.81	23.03	19.29	12.20	298		
	3	80	15	15	15.12	8.86	24.80	17.52	13.78	25.00	20.87	12.20	357		
	4	100	18	18	18.12	10.04	28.54	20.28	13.78	31.50	26.77	12.20	631		
	6	150	24	24	24.12	11.42	36.02	25.20	15.75	39.17	33.95	12.20	1773		
	8	200	29	29	29.12	18.11	45.28	31.50	19.69	49.21	39.37	18.11	2138		
	10	250	33	33	33.12	22.05	55.75	41.54	19.69	55.91	44.88	18.11	2877		
	12	300	38	38	38.12	25.98	62.80	45.87	23.62	62.99	48.43	18.11	4409		
	14	350	40.5	40.5	40.88	30.31	/	/	/	70.87	55.12	18.11	5732		
	16	400	44.5	44.5	44.88	33.07	/	/	/	77.82	63.78	18.11	7077		
	18	450	48	48	48.5	36.22	/	/	/	88.98	70.28	18.11	8818		
	20	500	52	52	52.5	39.37	/	/	/	99.21	76.77	18.11	11288		
	24	600	61	61	61.75	47.24	/	/	/	104.33	82.68	18.11	20723		
	24	600	1549	1549	1568	1200	/	/	/	2650	2100	460	9400		

Slab & Expanding Gate Valve Dimensions

Size: 2" - 12"
Class: 1500

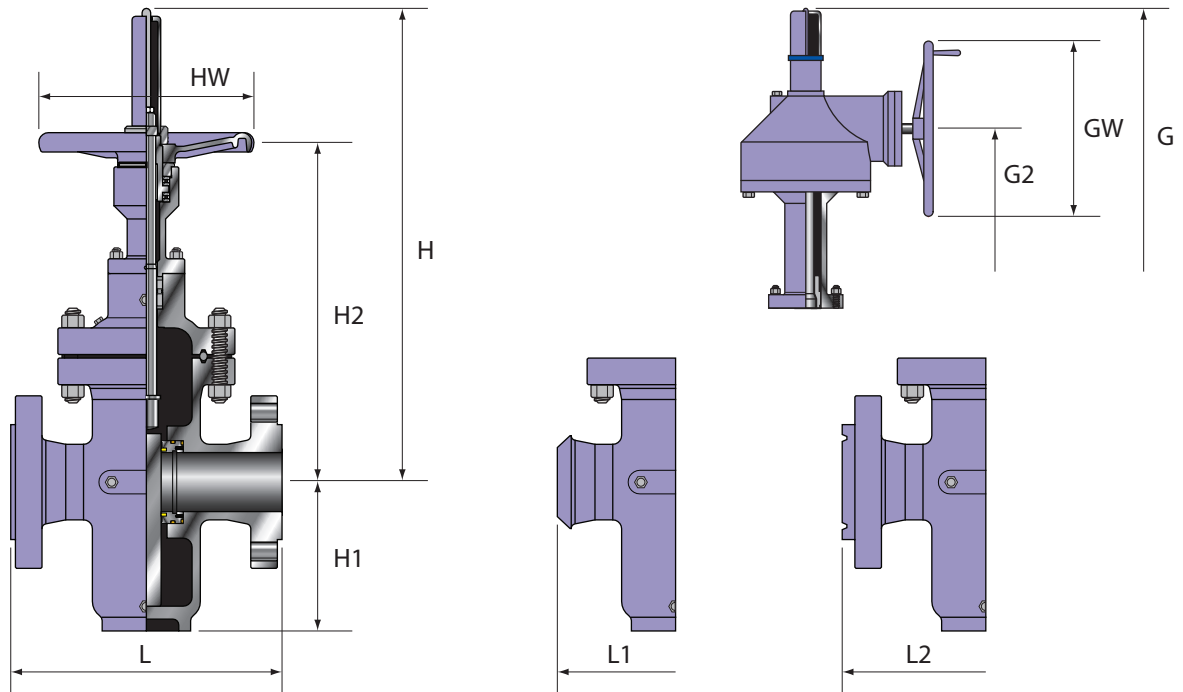

CLASS 1500	SIZE		END-TO-END			CENTER-TO-BOTTOM		HANDWHEEL OPERATED			GEAR OPERATED			WEIGHTS LBS/KG
	IN	MM	RF - L	BW - L1	RTJ - L2	H1	H	H2	HW	G	G2	GW		
	2	50	14.5	14.5	14.62	6.50	18.90	13.58	13.78	21.26	14.17	12.20	265	
	2.5	65	16.5	16.5	16.62	7.99	23.43	17.72	13.78	23.54	19.69	12.20	373	
	3	80	18.5	18.5	18.62	9.06	25.59	18.50	15.75	25.59	21.46	18.11	573	
	4	100	21.5	21.5	21.62	10.59	29.13	20.67	17.72	31.89	27.95	18.11	838	
	6	150	27.75	27.75	28	13.39	38.58	25.59	19.69	42.13	33.07	18.11	2006	
	8	200	32.75	32.75	33.13	16.54	/	/	/	53.15	41.34	18.11	3351	
	10	250	39	39	39.38	20.08	/	/	/	58.26	46.46	18.11	5027	
	12	300	44.5	44.5	45.12	23.23	/	/	/	66.14	51.18	18.11	7275	

Cv Values

The flow co-efficiency (Cv) of a valve is the rate of gallons per minute of water at 60° F through a fully opened valve at a pressure drop of 1 PSI across the valve.

SIZE	300	600	900	1500	2500
2	432	378	337	337	218
3 x 2	/	165	203	239	/
2.5	/	682	558	558	305
3	1155	1109	1072	966	474
4 x 3	/	529	597	677	624
4	2176	1944	1890	1730	725
6 x 4	/	944	943	1231	/
6	5300	4577	4383	3622	2510
8 x 6	2499	3240	3588	2137	/
8	11054	8886	8416	6879	5227
10 x 8	5218	5036	7975	4859	/
10	18856	14533	14087	11283	8313
12	28980	22729	21025	16843	12282
14	30883	28837	23846	20336	/
16	42224	39144	33358	27548	21396
18	55740	51368	45004	/	/
20	70386	64559	56871	/	/
22	86869	80279	/	/	/
24	106835	97240	84836	/	/
26	123222	114905	/	/	/
28	114355	135267	/	/	/
30	170229	157401	133706	/	/
36	245362	224424	/	/	/

Optional Thermal Relief Modifications

With the expanding gate design, it is possible for Thermal Expansion to occur within the body cavity while the valve is in the closed position. A Thermal Relief system is available to allow the body cavity to relieve into the upstream side of the valve.



SCV installed Thermal Relief system on 16" Class 600 Thru Conduit Gate Valve

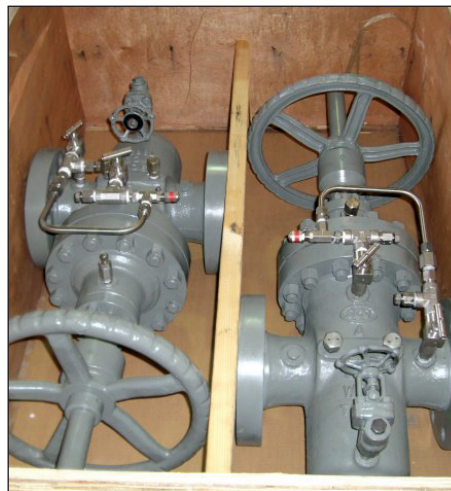

SCV installed Thermal Relief system on 4" Class 600 Thru Conduit Gate Valves

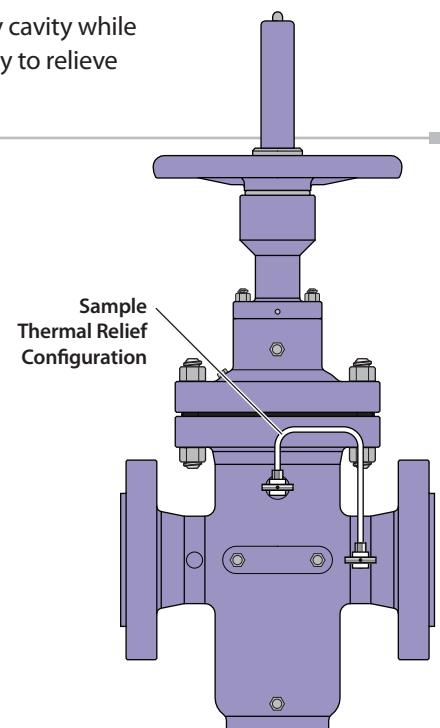

Pressure Temperature Ratings - ASME B16.34 ■■■■■■■■■■

Note: Pressures in PSI

	Temp. F	A105	WCB	LF2	WCC	LCB	WC6	LCC	C5	C12	C12A	316	CF8M	F51	F53
	150	-20 to 100	285	285	285	290	265	290	290	290	290	290	275	275	290
	200	260	260	260	260	255	260	260	260	260	260	235	235	260	260
	300	230	230	230	230	230	230	230	230	230	230	215	215	230	230
	400	200	200	200	200	200	200	200	200	200	200	195	195	200	200
	500	170	170	170	170	170	170	170	170	170	170	170	170	170	170
	600	140	140	140	140	140	140	140	140	140	140	140	140	140	140
	650	125	125	125	125	125	125	125	125	125	125	125	125	125	125
	700	110	110	110	110	110	110	110	110	110	110	110	110	110	110
	750	95	95	95	95	95	95	95	95	95	95	95	95	95	95
	800	80	80	80	80	80	80	80	80	80	80	80	80	/	/
	850	65	65	65	65	65	65	65	65	65	65	65	65	/	/
	900	50	50	50	50	50	50	50	50	50	50	50	50	/	/
	950	35	35	35	35	35	35	35	35	35	35	35	35	/	/
	1000	20	20	20	20	20	20	20	20	20	20	20	20	/	/
	1050	/	/	/	/	/	20	/	20	20	20	20	20	/	/
	1100	/	/	/	/	/	20	/	20	20	20	20	20	/	/
	1150	/	/	/	/	/	20	/	20	20	20	20	20	/	/
	1200	/	/	/	/	/	15	/	15	20	20	20	20	/	/
	1250	/	/	/	/	/	/	/	/	/	/	20	20	/	/
	1300	/	/	/	/	/	/	/	/	/	/	20	20	/	/
	1350	/	/	/	/	/	/	/	/	/	/	20	20	/	/
	1400	/	/	/	/	/	/	/	/	/	/	20	20	/	/
	1450	/	/	/	/	/	/	/	/	/	/	20	20	/	/
	1500	/	/	/	/	/	/	/	/	/	/	15	15	/	/
300	Temp. F	A105	WCB	LF2	WCC	LCB	WC6	LCC	C5	C12	C12A	316	CF8M	F51	F53
	-20 to 100	740	740	740	750	695	750	750	750	750	750	720	720	750	750
	200	680	680	680	750	660	750	750	750	750	750	620	620	745	745
	300	655	655	655	730	640	720	730	730	730	730	560	560	665	665
	400	635	635	635	705	615	695	705	705	705	705	515	515	615	615
	500	605	605	605	665	585	665	665	665	665	665	480	480	580	580
	600	570	570	570	605	550	605	605	605	605	605	450	450	555	555
	650	550	550	550	590	535	590	590	590	590	590	440	440	545	545
	700	530	530	530	555	510	570	555	570	570	570	435	435	540	540
	750	505	505	505	505	475	530	505	530	530	530	425	425	530	530
	800	410	410	410	410	390	510	410	510	510	510	420	420	/	/
	850	320	320	320	320	300	485	320	485	485	485	420	420	/	/
	900	230	230	230	225	200	450	225	375	450	450	415	415	/	/
	950	135	135	135	135	135	320	135	275	375	385	385	385	/	/
	1000	85	85	85	85	85	215	85	200	255	365	365	365	/	/
	1050	/	/	/	/	/	145	/	145	170	360	160	160	/	/
	1100	/	/	/	/	/	95	/	100	115	300	305	305	/	/
	1150	/	/	/	/	/	65	/	60	75	225	235	235	/	/
	1200	/	/	/	/	/	40	/	35	50	145	185	185	/	/
	1250	/	/	/	/	/	/	/	/	/	/	145	145	/	/
	1300	/	/	/	/	/	/	/	/	/	/	115	115	/	/
	1350	/	/	/	/	/	/	/	/	/	/	95	95	/	/
	1400	/	/	/	/	/	/	/	/	/	/	75	75	/	/
	1450	/	/	/	/	/	/	/	/	/	/	60	60	/	/
	1500	/	/	/	/	/	/	/	/	/	/	40	40	/	/

Pressure Temperature Ratings - ASME B16.34 ■■■■■■■■■■

Note: Pressures in PSI

	Temp. F	A105	WCB	LF2	WCC	LCB	WC6	LCC	C5	C12	C12A	316	CF8M	F51	F53
	600	-20 to 100	1480	1480	1480	1500	1395	1500	1500	1500	1500	1500	1440	1440	1500
	200	1360	1360	1360	1500	1320	1500	1500	1500	1500	1500	1240	1240	1490	1490
	300	1310	1310	1310	1455	1275	1445	1455	1455	1455	1455	1120	1120	1335	1335
	400	1265	1265	1265	1405	1230	1385	1405	1410	1410	1410	1025	1025	1230	1230
	500	1205	1205	1205	1330	1175	1330	1330	1330	1330	1330	995	995	1160	1160
	600	1135	1135	1135	1210	1105	1210	1210	1210	1210	1210	900	900	1115	1115
	650	1100	1100	1100	1175	1065	1175	1175	1175	1175	1175	885	885	1095	1095
	700	1060	1060	1060	1110	1025	1135	1110	1135	1135	1135	870	870	1085	1085
	750	1015	1015	1015	1015	955	1065	1015	1065	1065	1065	855	855	1065	1065
	800	825	825	825	825	780	1015	825	1015	1015	1015	845	845	/	/
	850	640	640	640	640	595	975	640	975	975	975	835	835	/	/
	900	460	460	460	445	405	900	445	745	900	900	830	830	/	/
	950	275	275	275	275	275	640	275	550	755	775	775	775	/	/
	1000	170	170	170	170	170	430	170	400	505	725	725	725	/	/
	1050	/	/	/	/	/	290	/	290	345	720	720	720	/	/
	1100	/	/	/	/	/	190	/	200	225	605	610	610	/	/
	1150	/	/	/	/	/	130	/	125	150	445	475	475	/	/
	1200	/	/	/	/	/	80	/	70	105	290	370	370	/	/
	1250	/	/	/	/	/	/	/	/	/	/	295	295	/	/
	1300	/	/	/	/	/	/	/	/	/	/	235	235	/	/
	1350	/	/	/	/	/	/	/	/	/	/	190	190	/	/
	1400	/	/	/	/	/	/	/	/	/	/	150	150	/	/
	1450	/	/	/	/	/	/	/	/	/	/	115	115	/	/
	1500	/	/	/	/	/	/	/	/	/	/	85	85	/	/
900	Temp. F	A105	WCB	LF2	WCC	LCB	WC6	LCC	C5	C12	C12A	316	CF8M	F51	F53
	-20 to 100	2220	2220	2220	2250	2090	2250	2250	2250	2250	2250	2160	2160	2250	2250
	200	2035	2035	2035	2250	1980	2250	2250	2250	2250	2250	1860	1860	2230	2230
	300	1965	1965	1965	2185	1915	2165	2185	2185	2185	2185	1680	1680	2000	2000
	400	1900	1900	1900	2110	1845	2080	2110	2115	2115	2115	1540	1540	1845	1845
	500	1810	1810	1810	1995	1760	1995	1995	1995	1995	1995	1435	1435	1740	1740
	600	1705	1705	1705	1815	1655	1815	1815	1815	1815	1815	1355	1355	1670	1670
	650	1650	1650	1650	1765	1600	1765	1765	1765	1765	1765	1325	1325	1640	1640
	700	1590	1590	1590	1665	1535	1705	1665	1705	1705	1705	1305	1305	1625	1625
	750	1520	1520	1520	1520	1430	1595	1520	1595	1595	1595	1280	1280	1595	1595
	800	1235	1235	1235	1235	1175	1525	1235	1525	1525	1525	1265	1265	/	/
	850	955	955	955	955	895	1460	955	1460	1460	1460	1255	1255	/	/
	900	690	690	690	670	605	1350	670	1120	1350	1350	1245	1245	/	/
	950	410	410	410	410	410	955	410	825	1130	1160	1160	1160	/	/
	1000	255	255	255	255	255	650	255	595	760	1090	1090	1090	/	/
	1050	/	/	/	/	/	430	/	430	515	1080	1080	1080	/	/
	1100	/	/	/	/	/	290	/	300	340	905	915	915	/	/
	1150	/	/	/	/	/	195	/	185	225	670	710	710	/	/
	1200	/	/	/	/	/	125	/	105	155	430	555	555	/	/
	1250	/	/	/	/	/	/	/	/	/	/	440	440	/	/
	1300	/	/	/	/	/	/	/	/	/	/	350	350	/	/
	1350	/	/	/	/	/	/	/	/	/	/	290	290	/	/
	1400	/	/	/	/	/	/	/	/	/	/	225	225	/	/
	1450	/	/	/	/	/	/	/	/	/	/	175	175	/	/
	1500	/	/	/	/	/	/	/	/	/	/	125	125	/	/

Pressure Temperature Ratings - ASME B16.34

Note: Pressures in PSI

1500	Temp. F	A105	WCB	LF2	WCC	LCB	WC6	LCC	C5	C12	C12A	316	CF8M	F51	F53
	-20 to 100	3705	3705	3705	3750	3480	3750	3750	3750	3750	3750	3750	3600	3600	3750
200	3395	3395	3395	3750	3300	3750	3750	3750	3750	3750	3750	3095	3095	3720	3720
300	3270	3270	3270	3640	3190	3610	3640	3640	3640	3640	3640	2795	2795	3335	3335
400	3170	3170	3170	3520	3075	3465	3520	3530	3530	3530	3530	2570	2570	3070	3070
500	3015	3015	3015	3325	2930	3325	3325	3325	3325	3325	3325	2390	2390	2905	2905
600	2840	2840	2840	3025	2755	3025	3025	3025	3025	3025	3025	2255	2255	2785	2785
650	2745	2745	2745	2940	2665	2940	2940	2940	2940	2940	2940	2210	2210	2735	2735
700	2665	2665	2665	2775	2560	2840	2775	2840	2840	2840	2840	2170	2170	2710	2710
750	2535	2535	2535	2535	2385	2660	2535	2660	2660	2660	2660	2135	2135	2660	2660
800	2055	2055	2055	2055	1955	2540	2055	2540	2540	2540	2540	2110	2110	/	/
850	1595	1595	1595	1595	1490	2435	1595	2435	2435	2435	2435	2090	2090	/	/
900	1150	1150	1150	1115	1010	2245	1115	1870	2245	2245	2245	2075	2075	/	/
950	685	685	685	685	685	1591	685	1370	1885	1930	1930	1930	1930	/	/
1000	430	430	430	430	430	1080	430	995	1270	1820	1820	1820	1820	/	/
1050	/	/	/	/	/	720	/	720	855	1800	1800	1800	1800	/	/
1100	/	/	/	/	/	480	/	495	565	1510	1525	1525	1525	/	/
1150	/	/	/	/	/	325	/	310	375	1115	1185	1185	1185	/	/
1200	/	/	/	/	/	205	/	170	255	720	925	925	925	/	/
1250	/	/	/	/	/	/	/	/	/	/	735	735	735	/	/
1300	/	/	/	/	/	/	/	/	/	/	585	585	585	/	/
1350	/	/	/	/	/	/	/	/	/	/	480	480	480	/	/
1400	/	/	/	/	/	/	/	/	/	/	380	380	380	/	/
1450	/	/	/	/	/	/	/	/	/	/	290	290	290	/	/
1500	/	/	/	/	/	/	/	/	/	/	205	205	205	/	/
2500	Temp. F	A105	WCB	LF2	WCC	LCB	WC6	LCC	C5	C12	C12A	316	CF8M	F51	F53
	-20 to 100	6170	6170	6170	6250	5805	6250	6250	6250	3250	6250	6000	6000	6250	6250
200	5655	5655	5655	6250	5505	6250	6250	6250	6250	6250	6250	5160	5160	6200	6200
300	5450	5450	5450	6070	5315	6015	6070	6070	6070	6070	6070	4660	4660	5560	5560
400	5280	5280	5280	5865	5125	5775	5865	5880	5880	5880	5880	4280	4280	5120	5120
500	5025	5025	5025	5540	4885	5540	5540	5540	5540	5540	5540	3980	3980	4840	4840
600	4730	4730	4730	5040	4595	5040	5040	5040	5040	5040	5040	3760	3760	4640	4640
650	4575	4575	4575	4905	4440	4905	4905	4905	4905	4905	4905	3680	3680	4560	4560
700	4425	4425	4425	4630	4270	4730	4630	4730	4730	4730	4730	3620	3620	4520	4520
750	4230	4230	4230	4230	3970	4430	4230	4430	4430	4430	4430	3560	3560	4430	4430
800	3430	3430	3430	3430	3255	4230	3430	4230	4230	4230	4230	3520	3520	/	/
850	2655	2655	2655	2655	2485	4060	2655	4060	4060	4060	4060	3480	3480	/	/
900	1915	1915	1915	1855	1685	3745	1855	3115	3745	3745	3745	3460	3460	/	/
950	1145	1145	1145	1145	1145	3655	1145	2285	3145	3220	3220	3220	3220	/	/
1000	715	715	715	715	715	1800	715	1655	2115	3030	3030	3030	3030	/	/
1050	/	/	/	/	/	1200	/	1200	1430	3000	3000	3000	3000	/	/
1100	/	/	/	/	/	800	/	830	945	2515	2545	2545	2545	/	/
1150	/	/	/	/	/	545	/	515	630	1855	1970	1970	1970	/	/
1200	/	/	/	/	/	345	/	285	770	1200	1545	1545	1545	/	/
1250	/	/	/	/	/	/	/	/	/	/	1230	1230	1230	/	/
1300	/	/	/	/	/	/	/	/	/	/	970	970	970	/	/
1350	/	/	/	/	/	/	/	/	/	/	800	800	800	/	/
1400	/	/	/	/	/	/	/	/	/	/	630	630	630	/	/
1450	/	/	/	/	/	/	/	/	/	/	485	485	485	/	/
1500	/	/	/	/	/	/	/	/	/	/	345	345	345	/	/

Flange Dimensions - ANSI B16.5 & B16.47

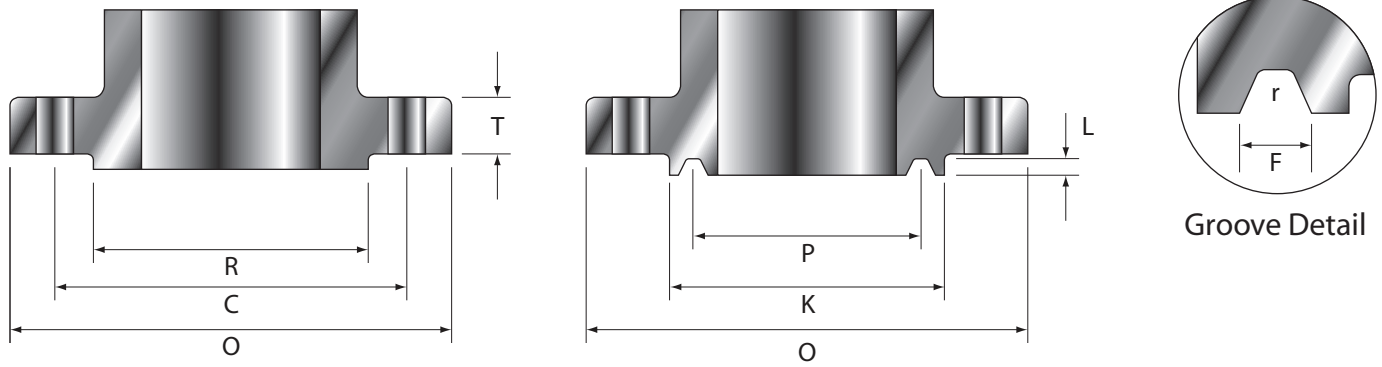

Class	Size	Flg. Dia.	Flg. Thick.	Raised Face Dia.	Drilling			Face Dia.	Ring Joint				
					Bolt Circle Dia.	# of Bolts	Hole Dia.		Pitch Dia.	Grv. Depth	Grv. Width	Btm. Radius	Ring No.
150	2	6.00	0.75	3.62	4.75	4	0.75	4.00	3.250	0.250	0.344	0.03	R22
	2.5	7.00	0.88	4.12	5.50	4	0.75	4.75	4.000	0.250	0.344	0.03	R25
	3	7.50	0.94	5.00	6.00	4	0.75	5.25	4.500	0.250	0.344	0.03	R29
	4	9.00	0.94	6.19	7.50	8	0.75	6.75	5.875	0.250	0.344	0.03	R36
	6	11.00	1.00	8.50	9.50	8	0.88	8.62	7.625	0.250	0.344	0.03	R43
	8	13.50	1.12	10.62	11.75	8	0.88	10.75	9.750	0.250	0.344	0.03	R48
	10	16.00	1.19	12.75	14.25	12	1.00	13.00	12.000	0.250	0.344	0.03	R52
	12	19.00	1.25	15.00	17.00	12	1.00	16.00	15.000	0.250	0.344	0.03	R56
	14	21.00	1.38	16.25	18.75	12	1.12	16.75	15.625	0.250	0.344	0.03	R59
	16	23.50	1.44	18.50	21.25	16	1.12	19.00	17.875	0.250	0.344	0.03	R64
	18	25.00	1.56	21.00	22.75	16	1.25	21.50	20.375	0.250	0.344	0.03	R68
	20	27.50	1.69	23.00	25.00	20	1.25	23.50	22.000	0.250	0.344	0.03	R72
	22	29.50	1.81	25.25	27.25	20	1.38	/	/	/	/	/	/
	24	32.00	1.88	27.25	29.50	20	1.38	28.00	26.500	0.250	0.344	0.03	R76
	26	34.25	2.69	29.50	31.75	24	1.38	/	29.500	0.500	0.781	0.060	R93
	28	36.50	2.81	31.50	34.00	28	1.38	/	31.500	0.500	0.781	0.060	R94
30	38.75	2.94	33.75	36.00	28	1.38	/	33.750	0.500	0.781	0.060	R95	
32	41.75	3.19	36.00	38.50	28	1.62	/	36.000	0.562	0.906	0.060	R96	
34	43.75	3.25	38.00	40.50	32	1.62	/	38.000	0.562	0.906	0.060	R97	
36	46.00	3.56	40.25	42.75	32	1.62	/	40.250	0.562	0.906	0.060	R98	
300	2	6.50	0.88	3.62	5.00	8	0.75	4.25	3.250	0.312	0.469	0.03	R23
	2.5	7.50	1.00	4.12	5.88	8	0.88	5.00	4.000	0.312	0.469	0.03	R26
	3	8.25	1.12	5.00	6.62	8	0.88	5.75	4.875	0.312	0.469	0.03	R31
	4	10.00	1.25	6.19	7.88	8	0.88	6.88	5.875	0.312	0.469	0.03	R37
	6	12.50	1.44	8.50	10.62	12	0.88	9.50	8.312	0.312	0.469	0.03	R45
	8	15.00	1.62	10.62	13.00	12	1.00	11.88	10.625	0.312	0.469	0.03	R49
	10	17.50	1.88	12.75	15.25	16	1.12	14.00	12.750	0.312	0.469	0.03	R53
	12	20.50	2.00	15.00	17.75	16	1.25	16.25	15.000	0.312	0.469	0.03	R57
	14	23.00	2.12	16.25	20.25	20	1.25	18.00	16.500	0.312	0.469	0.03	R61
	16	25.50	2.25	18.50	22.50	20	1.38	20.00	18.500	0.312	0.469	0.03	R65
	18	28.00	2.38	21.00	24.75	24	1.38	22.62	21.000	0.312	0.469	0.03	R69
	20	30.50	2.50	23.00	27.00	24	1.38	25.00	23.000	0.375	0.531	0.06	R73
	22	33.00	2.62	25.25	29.25	24	1.62	27.00	25.000	0.438	0.594	0.06	R81
	24	36.00	2.75	27.25	32.00	24	1.62	29.50	27.250	0.438	0.656	0.06	R77
	26	38.25	3.31	29.50	34.50	28	1.75	31.88	29.500	0.500	0.781	0.06	R93
	28	40.75	3.56	31.50	37.00	28	1.75	33.88	31.500	0.500	0.781	0.06	R94
30	43.00	3.75	33.75	39.25	28	1.88	36.12	33.750	0.500	0.781	0.06	R95	
32	45.25	3.94	36.00	41.50	28	2.00	38.75	36.000	0.562	0.906	0.06	R96	
34	47.50	4.12	38.00	43.50	28	2.00	40.75	38.000	0.562	0.906	0.06	R97	
36	50.00	4.38	40.25	46.00	32	2.12	43.00	40.250	0.562	0.906	0.06	R98	

Flange Dimensions - ANSI B16.5 & B16.47

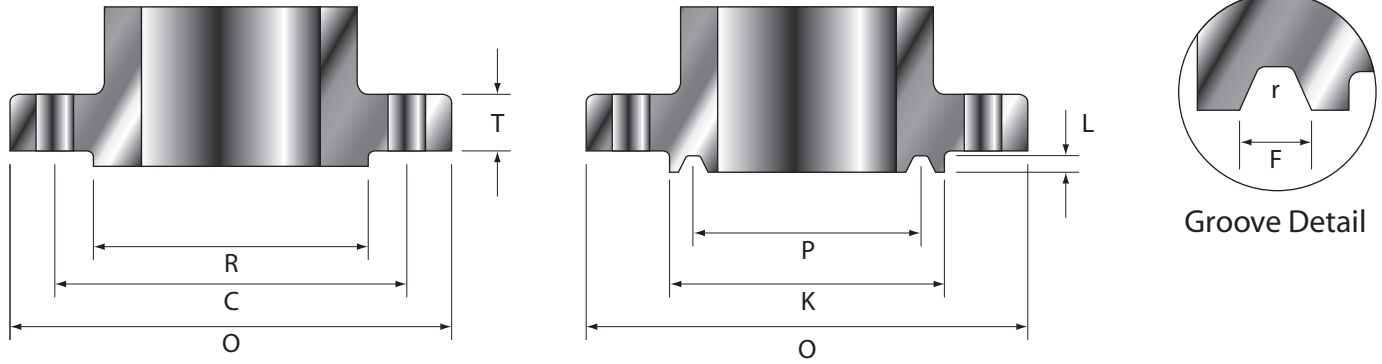

Class	Size	Flg. Dia.	Flg. Thick.	Circle Raise	Drilling			Face Dia.	Ring Joint				
					Bolt Circle Dia.	# of Bolts	Hole Dia.		Pitch Dia.	Grv. Depth	Grv. Width	Btm. Radius	Ring No.
600	2	6.50	1.00	3.62	5.00	8	0.75	4.25	3.250	0.312	0.469	0.03	R23
	2.5	7.50	1.12	4.12	5.88	8	0.88	5.00	4.000	0.312	0.469	0.03	R26
	3	8.25	1.25	5.00	6.62	8	0.88	5.75	4.875	0.312	0.469	0.03	R31
	4	10.75	1.50	6.19	8.50	8	1.00	6.88	5.875	0.312	0.469	0.03	R37
	6	14.00	1.88	8.50	11.50	12	1.12	9.50	8.312	0.312	0.469	0.03	R45
	8	16.50	2.19	10.62	13.75	12	1.25	11.88	10.625	0.312	0.469	0.03	R49
	10	20.00	2.50	12.75	17.00	16	1.38	14.00	12.750	0.312	0.469	0.03	R53
	12	22.00	2.62	15.00	19.25	20	1.38	16.25	15.000	0.312	0.469	0.03	R57
	14	23.75	2.75	16.25	20.75	20	1.5	18.00	16.500	0.312	0.469	0.03	R61
	16	27.00	3.00	18.50	23.75	20	1.62	20.00	18.500	0.312	0.469	0.03	R65
	18	29.25	3.25	21.00	25.75	20	1.75	22.62	21.000	0.312	0.469	0.03	R69
	20	32.00	3.50	23.00	28.50	24	1.75	25.00	23.000	0.375	0.531	0.06	R73
22	34.25	3.75	25.25	30.62	24	1.88	27.00	25.000	0.438	0.594	0.06	R81	
24	37.00	4.00	27.25	33.00	24	2.00	29.50	27.250	0.438	0.659	0.06	R77	
900	2	8.5	1.5	3.62	6.5	8	1	4.88	3.75	0.312	0.469	0.03	R24
	2.5	9.62	1.62	4.12	7.50	8	1.12	5.39	4.250	0.312	0.469	0.03	R27
	3	9.50	1.50	5.00	7.50	8	1.00	6.12	4.875	0.312	0.469	0.03	R31
	4	11.50	1.75	6.19	9.25	8	1.25	7.12	5.875	0.312	0.469	0.03	R37
	6	15.50	2.19	8.50	12.50	12	1.25	9.50	8.312	0.312	0.469	0.03	R45
	8	18.50	2.50	10.62	15.50	12	1.50	12.12	10.625	0.312	0.469	0.03	R49
	10	21.50	2.75	12.75	18.50	16	1.50	14.25	12.750	0.312	0.469	0.03	R53
	12	24.00	3.12	15.00	21.00	20	1.50	16.50	15.000	0.312	0.469	0.03	R57
	14	25.25	3.38	16.25	22.00	20	1.62	18.38	16.500	0.438	0.656	0.06	R62
	16	27.75	3.50	18.50	24.25	20	1.75	20.62	18.500	0.438	0.656	0.06	R66
	18	31.00	4.00	21.00	27.00	20	2.00	23.38	21.00	0.500	0.781	0.06	R70
	20	33.75	4.25	23.00	29.50	20	2.12	25.50	23.000	0.500	0.781	0.06	R74
24	41.00	5.50	27.25	35.50	20	2.62	30.38	27.250	0.625	1.062	0.09	R78	
1500	2	8.50	1.50	3.62	6.50	8	1.00	4.88	3.750	0.312	0.469	0.03	R24
	2.5	9.62	1.62	4.12	7.50	8	1.12	5.38	4.250	0.312	0.469	0.03	R27
	3	10.50	1.88	5.00	8.00	8	1.25	6.62	5.375	0.312	0.469	0.03	R35
	4	12.25	2.12	6.19	9.50	8	1.38	7.62	6.375	0.312	0.469	0.03	R39
	6	15.50	3.25	8.50	12.50	12	1.50	9.75	8.312	0.375	0.531	0.06	R46
	8	19.00	3.62	10.62	15.50	12	1.75	12.50	10.625	0.438	0.656	0.06	R50
	10	23.00	4.25	12.75	19.00	12	2.00	14.62	12.750	0.438	0.656	0.06	R54
	12	26.00	4.88	15.00	22.50	16	2.12	17.25	15.000	0.562	0.906	0.06	R58
	14	29.50	5.25	16.25	25.00	16	2.38	19.25	16.500	0.625	1.062	0.09	R63
	16	32.50	5.75	18.50	27.75	16	2.62	21.50	18.500	0.688	1.188	0.09	R67
	18	36.00	6.38	21.00	30.50	16	2.88	24.12	21.000	0.688	1.188	0.09	R71
	20	38.75	7.00	23.00	32.75	16	3.12	26.50	23.000	0.688	1.312	0.09	R75
24	46.00	8.00	27.25	39.00	16	3.62	31.25	27.250	0.812	1.438	0.09	R79	
2500	2	9.25	2.00	3.62	6.75	8	1.00	4.48	4.000	0.312	0.469	0.030	R26
	2.5	10.50	2.25	4.12	7.75	8	1.13	5.86	4.375	0.375	0.531	0.060	R28
	3	12.00	2.62	5.00	9.00	8	1.25	6.61	5.000	0.375	0.531	0.060	R32
	4	14.00	3.00	6.19	10.75	8	1.50	7.99	6.188	0.438	0.656	0.060	R38
	5	16.50	3.62	7.31	12.75	8	1.75	9.48	7.500	0.500	0.781	0.060	R40
	6	19.00	4.25	8.50	14.50	8	2.00	10.98	9.000	0.500	0.781	0.060	R47
	8	21.75	5.00	10.62	17.25	12	2.00	13.38	11.000	0.562	0.906	0.060	R51
	10	26.50	6.50	12.75	21.75	12	2.50	16.73	13.500	0.688	1.188	0.090	R55
12	30.00	7.25	15.00	24.38	12	2.75	19.48	16.000	0.688	1.312	0.090	R60	

Southern California is not only known for awesome waves and sunsets.

Since 1972, **Southern California Valve** has been committed to providing quality flow control products to the Power, Paper & Pulp, Oil & Gas, and Petro Chemical industries.

As one of the largest valve manufacturers on the West Coast, **Southern California Valve's** reputation is unparalleled for producing high quality commodity and specialty valves. Our \$40 million ready-to-ship inventory is backed by timely deliveries and competitive prices on valves ranging from 1/4" thru 52", in pressure classes 150# thru 2500#.

Southern California Valve has a total of six strategic stocking location throughout North America including both of our corporate locations.

Call SCV today at (281) 482-4728 for your valve needs or visit us on the web @ www.scvvalve.com.

Visit us at the **Valve World Expo 2010 Düsseldorf - 7th Biennial Valve World Conference & Exhibition** in Düsseldorf, Germany on November 30 thru December 2, 2010. **Booth #3G72**

API 6D SS

Trunnion Balls 3-Piece & Top Entry Bolted & Welded Body

Sizes: 2" - 24"
Class: 150 - 2500

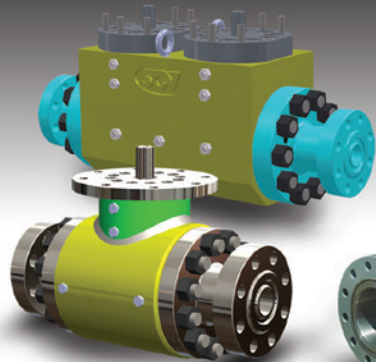

API 6A

Trunnion Balls 3-Piece

Sizes: 2-1/16" - 13-5/8"
Pressure: 2000, 3000, & 5000

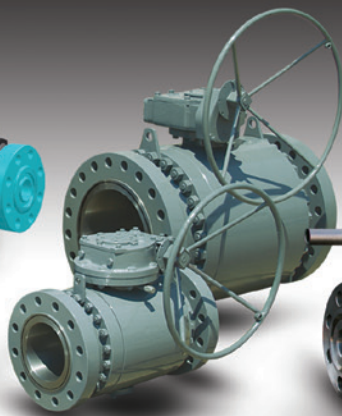

API 6D

Trunnion Balls Double Block & Bleed

Sizes: 2" - 16"
Class: 150 - 2500

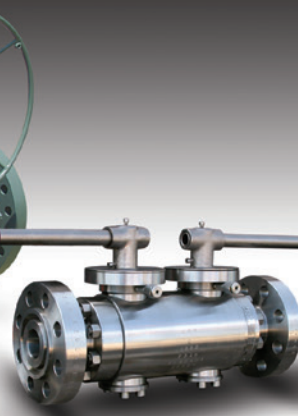

Trunnion Balls Bolted & Welded Body

Sizes: 1" - 48"
Class: 150 - 2500



API 6D

Piston Checks

Sizes: 1" - 24"
Class: 150 - 2500



Swing Checks Full Port

Sizes: 2" - 52"
Class: 150 - 2500



Thru Conduit Gates Slab & Expanding

Sizes: 2" - 48"
Class: 150 - 2500

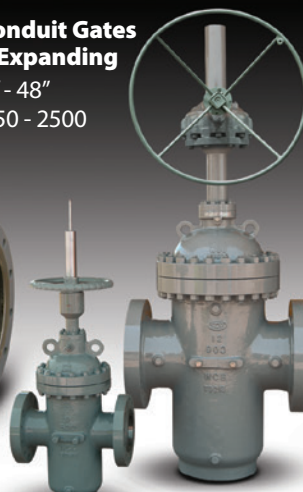

Dual Plate Checks Wafer & Flanged

Wafer Sizes: 1.5" - 84"
Wafer Class: 150 - 2500
Flanged Sizes: 8" - 48"
Flanged Class: 150 - 900

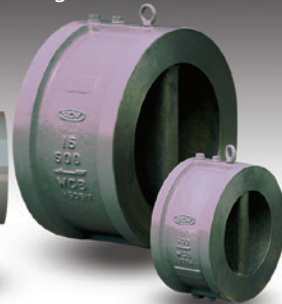

Southern California Valve
Innovative Valve Solutions®

Sales, Projects, Manufacturing, & Warehousing

3521 FM 646 Rd. North
Santa Fe, TX 77510
Phone: (281) 482-4728
Fax: (281) 482-9728

Manufacturing, & Warehousing

13903 Maryton Ave.
Santa Fe Springs, CA 90670
Toll Free: (800) 554-6421
Phone: (562) 404-2246
Fax: (562) 404-2836

Butt-welding Dimensions - ANSI B16.25 ■■■■■■■■■■

Nominal Pipe Size	Schedule Number or Wall	Outside Diameter (Cast Steel Valves) A		Nominal Inside Diameter B		Machined Inside Diameter C		Nominal Wall Thickness t	
		Inches	mm	Inches	mm	Inches	mm	Inches	mm
3	xxs	3-19/32	91.282	2.300	58.42	2.409	61.19	0.600	15.24
4	xxs	4-5/8	117.48	3.152	80.06	3.279	83.29	0.674	17.12
5	160	5-11/16	144.46	4.313	109.55	4.428	112.47	0.625	15.88
	xxs			4.063	103.20	4.209	106.91	0.750	19.05
6	120	6-25/32	172.34	5.501	139.72	5.600	142.24	0.562	14.27
	160			5.189	131.80	5.327	135.31	0.719	18.26
	xxs			4.897	124.38	5.072	128.83	0.864	21.95
8	100	8-23/32	223.04	7.439	188.93	7.546	191.67	0.594	15.09
	120			7.189	182.60	7.327	186.11	0.719	18.26
	140			7.001	177.83	7.163	181.94	0.812	20.62
	xxs			6.875	174.63	7.053	179.15	0.875	22.23
	160			6.813	173.05	6.998	177.75	0.960	23.01
10	50	10-15/16	277.81	9.564	242.93	9.671	245.64	0.594	15.09
	100			9.314	236.58	9.452	240.08	0.719	18.26
	120			9.064	230.23	9.234	234.54	0.844	21.44
	140			8.750	222.25	8.959	227.56	1.000	25.40
	160			8.500	215.90	8.740	222.00	1.125	28.58
12	60	12-31/32	329.41	11.626	295.30	11.725	297.82	0.562	14.27
	80			11.376	288.95	11.507	292.28	0.688	17.48
	100			11.064	281.03	11.234	284.34	0.844	21.44
	120			10.750	273.05	10.959	278.36	1.000	25.40
	140			10.500	266.70	10.740	272.80	1.125	28.58
	160			10.126	257.20	10.413	264.49	1.312	33.32
14	60	14-1/4	361.95	12.814	352.48	12.921	328.19	0.594	15.09
	80			12.500	317.50	12.646	321.21	0.750	19.05
	100			12.126	308.00	12.319	312.90	0.938	23.83
	120			11.814	300.08	12.046	305.97	1.094	27.79
	140			11.500	292.10	11.771	298.98	1.250	31.75
	160			11.188	284.18	11.498	292.05	1.406	35.71
16	60	16-1/4	412.75	14.688	373.08	14.811	376.20	0.656	16.66
	80			14.314	363.58	14.484	367.89	0.844	21.44
	100			13.938	354.03	14.155	359.54	1.031	26.19
	120			13.564	344.53	13.827	351.21	1.219	30.96
	140			13.124	333.35	13.442	341.43	1.438	36.53
	160			12.814	325.48	13.171	334.54	1.594	40.49
18	40	18-9/32	464.34	16.876	428.65	16.975	431.17	0.562	14.27
	60			16.500	419.10	16.646	422.81	0.750	19.05
	80			16.126	409.60	16.319	414.50	0.938	23.83
	100			15.688	398.48	15.936	404.50	1.156	29.36
	120			15.250	387.35	15.553	395.05	1.375	34.93
	140			14.876	377.85	15.225	386.72	1.562	39.67
	160			14.438	366.73	14.842	376.99	1.781	45.24
20	40	20-5/16	515.94	18.814	477.88	18.921	480.59	0.594	15.09
	60			18.376	466.75	18.538	470.87	0.812	20.62
	80			17.938	455.63	18.155	461.14	1.031	26.19
	100			17.438	442.93	17.717	450.01	1.281	32.54
	120			17.000	431.80	17.334	440.28	1.500	38.10
	140			16.500	419.10	16.896	429.16	1.750	44.45
	160			16.064	408.03	16.515	419.48	1.969	50.01
24	30	24-3/8	619.13	22.876	581.05	22.975	583.57	0.562	14.27
	40			22.626	574.70	22.757	578.03	0.688	17.48
	60			22.064	560.43	22.265	565.53	0.969	24.61
	80			21.564	547.73	21.827	554.41	1.219	30.96
	100			20.938	531.83	21.280	540.51	1.531	38.89
	120			20.376	517.55	20.788	528.02	1.812	46.02
	140			19.876	504.85	20.350	516.89	2.062	52.37
	160			19.314	490.58	19.859	504.42	2.344	59.54

Butt-welding Dimensions - ANSI B16.25

Plain Bevel Butt-welding End for Pipe Wall Thickness is 7/8" (22.23mm) or less.

Welding end details for cast components for use without backing ring or with split backing ring.

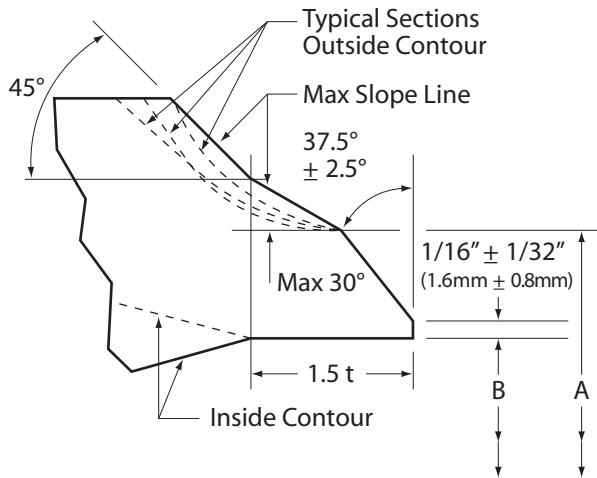

Compound Bevel Butt-welding End for Pipe Wall Thickness Greater than 7/8" (22.23mm).

Welding end details for cast components for use without backing ring or with split backing ring.

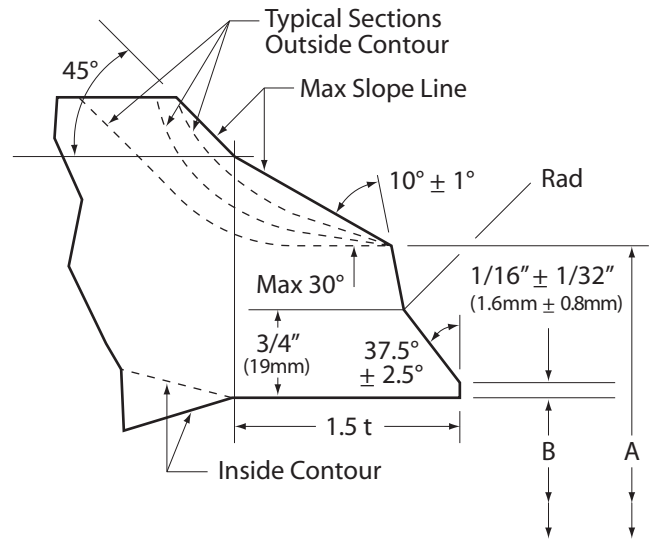

Plain Bevel Butt-welding End for Pipe Wall Thickness is 7/8" (22.23mm) or less.

Welding end details for cast components for use with continuous rectangular or tapered backing ring.

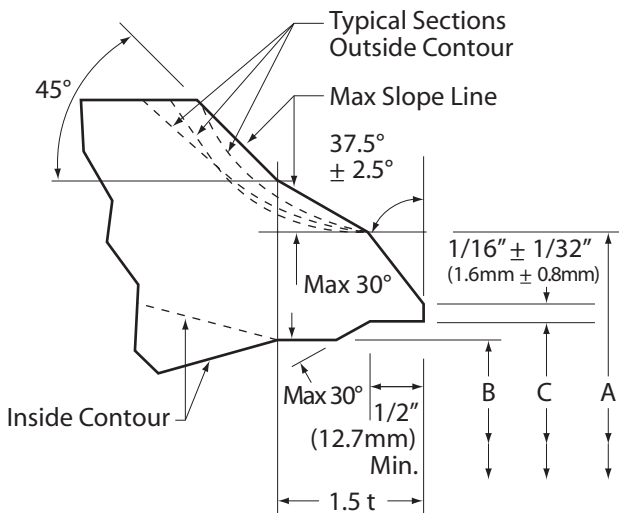

Compound Bevel Butt-welding End for Pipe Wall Thickness Greater than 7/8" (22.23mm).

Welding end details for cast components for use with continuous rectangular or tapered backing ring.

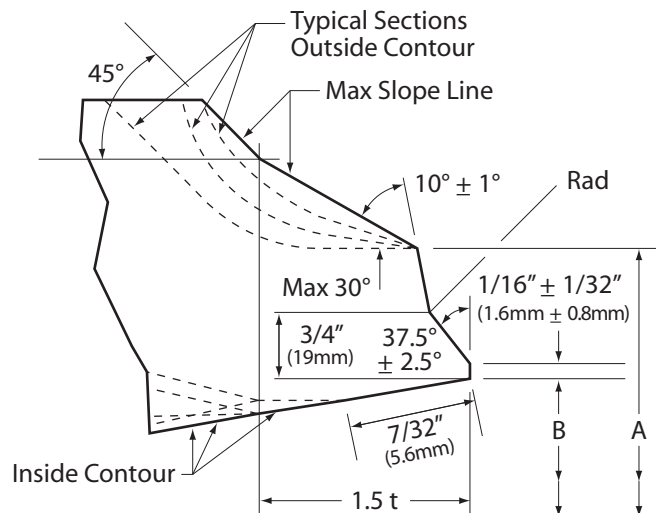

Industry Standards for Valve Manufacturing

This information is for reference only.

American Society of Mechanical Engineers (ASME)

ASME Code - Boiler & pressure vessel code
ASME A13.1 - Scheme for the identification of piping systems
ASME B1.1 - Unified inch screw threads, UN, & UNR thread form
ASME B1.5 - ACME screw threads
ASME B1.7M - Nomenclature, definitions, & letter symbols for screw threads
ASME B1.8 - Stub ACME screw threads
ASME B1.12 - Class 5 interference - fit thread
ASME B1.20.1 - Pipe threads, general purpose, inch
ASME B1.20.3 - Dry-seal pipe threads, inch
ANSI/ASME B16.1 - Cast iron pipe flanges & flanged fittings
ANSI/ASME B16.5 - Pipe flanges & flanged fittings: NPS 1/2" - 24"
ASME B16.9 - Factory made wrought steel butt welding fittings
ANSI/ASME B16.10 - Face-to-face & end-to-end dimensions of valves
ASME B16.11 - Forged fittings, socket welding & threaded
ASME B16.20 - Metallic gaskets for pipe flanges: ring joint spiral wound & jacketed
ASME B16.21 - Non-metallic flat gaskets for pipe flanges
ASME B16.25 - Butt welding ends
ANSI/ASME B16.33 - Manually operated metallic gas valves for use in gas piping systems up to 125 PSI (sizes NPS 1/2" - 2")
ANSI/ASME B31.1 - Power piping
ANSI/ASME B31.3 - Process piping
ANSI/ASME B16.34 - Valves flanged, threaded & welding end
ANSI/ASME B16.36 - Orifice flanges
ANSI/ASME B16.38 - Large metallic valves for gas distribution (manually operated, NPS 2-1/2" - 12", 125 PSIG maximum)
ANSI/ASME B16.42 - Ductile iron pipe flanges & flanged fittings: classes 150 & 300
ANSI/ASME B16.47 - Large diameter steel flanges
ANSI B17.1 - Keys & keyseats
ANSI B18.2.2 - Square & hex nuts
ASME B31.4 - Pipeline transportation systems for liquid hydrocarbons & other ammonia & alcohols
ANSI/ASME B31.8 - Gas transmission & distribution piping systems
ANSI/ASME B36.10 - Welded & seamless wrought steel pipe
ANSI/ASME B36.19 - Stainless steel pipe
ANSI FCI-2 - Control valve seat leakage

American Society Non-destructive Test (ASNT)

ASNT-TC-1A - Recommended practice no. SNT-TC-1A 1996

American Society for Testing and Materials (ASTM)

American Petroleum Institute (API)

API RP 574 - Inspection practices for piping system components
API 589 - Fire test for evaluation of valve stem packing
API RP 591 - Process valve qualification procedure
API 594 - Check valves-flanged, lug, wafer & butt welding
API 597 - Steel venturi gate valves, flanged, butt welding ends
API 598 - Valve inspection & testing
API 599 - Metal plug valves - flanged, welding ends
API 601 - Metallic gaskets for raised-face pipe flanges & flanged connections (double-jacketed corrugated & spiral wound)
API 600 - Bolted bonnet steel gate valves for petroleum & natural gas industries "ISO adoption from ISO 10434"
API 602 - Steel gate, globe, & check valves for sizes DN100 and smaller for the petroleum & natural gas industries
API 603 - Corrosion-resistant, bolted bonnet gate valves-flanged & butt weld ends
API 604 - Ductile iron gate valves, flanged ends
API 605 - Large-diameter carbon steel flanges (nominal pipe sizes 26" - 60", classes 75, 150, 300, 400, 600, & 900 (replaced by ANSI/ASME B16.47)
API 606 - Compact steel gate valves, extended body (included in API 602) fire test for soft-seated quarter-turn valves "ISO adoption from ISO 10497-5 2004"
API 607 - Fire test for soft-seated quarter-turn valves "ISO adoption from ISO 10497-5 2004"
API 608 - Metal ball valves, flanged, threaded, & welding ends
API 609 - Butterfly valves-double flanged, lug- & wafer-type
API RP 941 - Steel for hydrogen service at elevated temperatures & pressures in petroleum refineries & petrochemical plants
API RP 520, Part 1 - Sizing, selection & installation of pressure relieving devices in refineries
API RP 520, Part 2 - Sizing, selection & installation of pressure relieving devices in refineries devices in refineries
API Spec 6A - Specification for wellhead & christmas tree equipment
API Spec 6D - Specifications for pipeline valves
API Spec 14D - Specifications for wellhead surface safety valves & underwater safety valves for offshore service
API 5B - Threading, gauging thread inspection of coring, tubing, & line pipe threads
API 6AM - Material toughness
API 6FA - Fire test for valves
API 6FC - Fire test for valves with backseats
API 6FD - Specification for fire test for check valves
API Q1 - Specification for quality programs for the petroleum, petrochemical, & natural gas

National Association of Corrosion Engineers (NACE)

MR0175 - Sulfide stress cracking resistant metallic materials for oil field equipment
MR0103 - Materials resistant to sulfide stress cracking in corrosive petroleum refining environments

British Standards Institute (BS)

BS 1414 - Gate, wedge & double disk valves: steel
BS 1868 - Check valves: steel
BS 1873 - Globe & check valves: steel
BS 2080 - Flanged & butt weld end steel valves
BS 5146 - (withdrawn) Replaced by BS 6755 p.1 steel valves testing (1986) & BS 6755 p.2 (1984)
BS 5152 - Globe & check: cast iron
BS 5153 - Check: cast iron
BS 5159 - Ball: cast iron & carbon steel
BS 5160 - Globe & check: steel
BS 5163 - Gate, wedge & double disk: cast iron
BS 5351 - Ball: steel
BS 5352 - Globe & check: steel
BS 5418 - (withdrawn) Replaced by BS EN 19 (1992) marking: general purpose industrial
BS 5840 - Valve mating details for actuator operation
BS 6364 - Cryogenic
BS 6683 - Guide: installation & use of valves
BS 6755: Part 1 - Specification for production pressure testing requirements
BS 6755: Part 2 - Specification for fire type-testing requirements
BS EN 19 - Marking of general purpose industrial valves

Canadian Standards Association

BS1-97 - Boiler, pressure vessel, & pressure piping code
Z245.15-96 - Steel valves
CAN3-z299.4-85 - Quality assurance program - Category 4
CAN3-z299.3-85 - Quality assurance program - Category 3

International Organization for Standardization

ISO 5211/1 - Industrial valves- part-turn actuator attachments
ISO 5211/2 - Part-turn valve actuator attachment-flange & coupling performance characteristics
ISO 5211/3 - Part-turn valve actuator attachment-dimensions of driving components
ISO 5752 - Metal valves for use in flanged pipe systems face-to-face & center-to-face dimensions
ISO 9000 - Quality management systems and fundamentals & vocabulary
ISO 10012-1 - Quality assurance requirements for measuring equipment

Manufacturers Standardization Society

SP-6 - Standard finishes for contact faces of pipe flanges & connecting-end flanges of valves & fittings
SP-9 - Spot facing for bronze, iron & steel flanges
SP-25 - Standard marking system for valves, fittings, flanges & unions
SP-42 - Class 150 corrosion resistant gate, globe, angle, & check valves with flanged & butt weld ends
SP-44 - Steel pipeline flanges
SP-45 - Bypass & drain connections
SP-51 - Class 150/w corrosion resistant cast flanges & flanged fittings
SP-53 - Quality standard for steel castings & forgings for valves, flanges, & fittings & other piping components: magnetic particle exam method
SP-54 - Quality standard for steel castings for valves, flanges, & fittings and other piping components: radiographic examination method
SP-55 - Quality standard for steel castings for valves, flanges other piping components-visual method for evaluation of surface irregularities
SP-60 - Connecting flange joint between tapping sleeves & tapping valves
SP-61 - Pressure testing of steel valves
SP-65 - High pressure chemical industry flanges & threaded stubs for use with lens gaskets
SP-67 - Butterfly valves
SP-69 - ANSI/MSS edition pipe hangers & supports, selection & application
SP-70 - Cast iron gate valves, flanged & threaded ends
SP-71 - Gray iron swing check valves, flanged & threaded ends
SP-72 - Ball valves with flanged or butt-welding ends for general service
SP-79 - Socket-welding reducer inserts
SP-81 - Stainless steel, bonnetless, flanged knife gate valves
SP-82 - Valve pressure testing methods
SP-84 - Valves - socket welding & threaded ends
SP-85 - Cast iron globe & angle valves, flanged & threaded ends
SP-86 - Guidelines for metric data in standards for valves, flanges, fittings & actuators
SP-88 - Diaphragm valves
SP-91 - Guidelines for manual operation of valves
SP-92 - MSS valve user guide
SP-93 - Quality standard for steel castings & forgings for valves, flanges & fittings & other piping components- liquid penetrant exam method
SP-94 - Quality standard for ferritic & martensitic steel castings for valves, flanges, & fittings and other piping components - ultrasonic exam method
SP-96 - Guidelines on terminology for valves & fittings
SP-98 - Protective coatings for the interior of valves, hydrants, & fittings
SP-99 - Instrument valves
SP-101 - Part-turn valve actuator attachment-flange and driving component dimensions & performance characteristics
SP-102 - Multi-turn valve actuator attachment: flange and driving component dimensions & performance characteristics
SP-110 - Ball valves threaded, socket-welding, solder joint, grooved, & flared ends
SP-117 - Bellows seals for globe & gate valves
SP-118 - Compact steel globe and check valves-flanged, flangeless, threaded & welding ends (chemical & petroleum refinery service)
SP-120 - Flexible graphite packing system for rising stem steel valves (design requirements)
SP-121 - Qualification testing methods for stem packing for rising stem steel valves

Terms & Conditions

Quotation Validity

This quotation is valid for 30 days from the date quotation is sent. Validity on special metals, including Stainless Steel, is 14 days from the date the quotation is sent. All products offered from stock are subject to prior sale.

Shipments

All items quoted are EXW our Dock - (Ex Works - SCV Facility Santa Fe Spings, California 90670) - unless otherwise noted and agreed to in writing. Shipment may be billed either third party billing to the buyer or freight collect. Shipment dates offered above are forecasted delivery lead times and are estimated from the date payment terms (acceptable to seller) are established, clarification is received on all technical information, and resolution of customer's written approval of drawings is received (when required). The equipment quoted shall be packed in accordance with seller's standard packing procedure unless otherwise noted and agreed to in writing by the seller.

Force Majeure

If in the case of an act of God, war, riot, fire, explosion, flood, or any other circumstances of whatsoever nature which are beyond the control of the seller and which in any way affect the ability of the seller to fulfill its delivery obligations, the delivery is hindered, impeded, or delayed the seller shall be exonerated from all responsibilities and reserves the right to postpone the delivery beyond the original schedule.

Payment terms

All terms are to be negotiated. Credit cards accepted (Master Card, Visa, American Express).

Purchase Orders

All buyer's purchase orders supplied to the seller are to be written in the English language.

Prices

All prices quoted are in USD as per the preceding pricing schedule. The minimum order value is \$5,000.00 (five thousand dollars), unless otherwise agreed to by seller. If for some reason any items are changed or additions to the order required, seller reserves the right to adjust prices accordingly. All sales are subject to approval of seller's credit department. If buyer fails to meet the agreed upon and established commercial terms of the contract, the seller may with-hold all subsequent deliveries until such time that the original commercial terms of the contract have been met by the buyer (or subsequent commercial terms have been agreed upon by the seller with the buyer).

Intellectual Property

All specifications, illustrations, drawings, certificates, and other particulars supplied by seller remain the intellectual property of the seller and should not be disclosed to any third party without the prior written consent of seller.

Governing Law; Arbitration; Jurisdiction

The terms and conditions of this quotation and any subsequent purchase order shall be construed, interpreted, and performed exclusively according to the laws of the State of Texas, USA. The courts of such state shall have exclusive jurisdiction out of all controversies arising out of or in connection with this agreement. The parties consent that process may be served upon them in any such action by registered mail at the address stated for Buyer on its purchase order, and upon SCV at the address noted above in Santa Fe, Texas, or personally within or without the State of Texas. Any legal action with respect to any agreement must be commenced within one year after the cause of action has accrued. The provisions of the Uniform Commercial Code as adopted by the State of Texas, and not under the United Nations Convention on Contracts for the International Sale of Goods, shall apply.

Warranty

All seller's products are guaranteed against defects in workmanship for a period of twelve (12) months after being placed in service, but not exceeding eighteen (18) months after shipment, when products are properly installed per seller specifications and used within the service and pressure range for which they were manufactured. Full risk of loss shall pass to the buyer upon delivery at FOB point, or destination port in case of CIF. This guarantee is limited to the replacement of any valve parts/components found to be defective either in material or workmanship. This guarantee does not extend to costs of labor, freight, or any other consequential charges. The unauthorized use of third party components and workmanship in seller's products voids this warranty.

Limitation of Liability

The liability of the seller under this agreement or with respect to any products supplied or services performed pursuant to this agreement, whether in contract, in tort, in strict liability or otherwise, shall not exceed the purchase price paid by the buyer with respect thereto. In no event will the seller be liable in contract, in tort, in strict liability or otherwise for any special, indirect, incidental, or consequential damages. This is including but not limited to loss of anticipated profits or revenues, loss of use, non-operation or increased expense of operation of equipment, cost of capital, or claims from customer or buyer for failure or delay in achieving anticipated profits or products.

Cancellation

No contract may be canceled by the buyer except upon written notice to seller and upon payment to seller of all costs incurred by the contract arising out of, or in connection with, the contract. Export of goods covered hereby is subject to United States Customs Control. Standard stocking items will be subject to a twenty-five percent (25%) restocking and/or cancellation charge. Non-standard stocking items will be subject to a one-hundred percent (100%) restocking and/or cancellation charge.

Cancellation Charge

The following indicates the rates of cancellation charge of contract value for project manufactured items and/or special engineered items at various stages of production:

- **Time of cancellation: Order Acknowledgement and prior to Engineering engagement.** Cancellation Charge: 10%
- **Time of cancellation: After start of engineering but prior to release to production.** Cancellation Charge: 30%
- **Time of cancellation: After release to production but prior to completion of fabrication.** Cancellation Charge: 80%
- **Time of cancellation: After completion of fabrication.** Cancellation Charge: 100%

Return of Goods

No product shall be returned to seller without written authorization and shipping instructions having been obtained from seller. Products authorized for returns are to be shipped freight pre-paid to the SCV Facility identified in writing, unless otherwise notified, and are subject to seller's standard re-stocking fees.

Documentation

MTR's are available at no charge upon request. The seller's standard document package is per ISO 10474 3.1B requirements. Additional requested documentation is subject to charge.

Inspection

The customer or his authorized representative may, with four (4) weeks prior notice given to seller, visually inspect products manufactured by seller. Such seller approved inspections will be carried out in accordance with seller's standard or seller approved customer inspection procedures. If any inspection or documentation requested by the customer is over and beyond the scope and criteria initially agreed to by the seller, any costs incurred by conducting such inspection or preparation of special documents shall be paid by the buyer prior to release of the items for shipment.

Witness Hydro-testing

Witness hydro-testing is available at a cost. A scope of buyers inspection request is to be provided to seller at order placement. Late notice of such requested inspection is subject to additional costs. The cost associated with such witness hydro request is to be agreed on prior to any such testing taking place. Payment of this type of testing to be negotiated. Additionally, any costs associated with a third party inspector will not be at the sellers expense.

Southern California Valve was established in 1972 as a maintenance and modification company with the ability to provide full in-line valve service and repair. In the mid-1970's, after experiencing the shortcomings of other valve products in service, SCV manufactured its first valve. Since that time, Southern California Valve has expanded our manufactured products to cover a broad range of valves. Industries served include the power, paper and pulp, oil and gas, and petro-chemical sectors.

Southern California Valve takes sincere pride in our ability to manufacture both commodity and specialty valves that meet and exceed the needs of our customers. All sizes, pressure classes, and metallurgical compositions are managed in house utilizing the strictest quality control measures to ensure the customer's total satisfaction.

Southern California Valve products include gates, globes, checks, balls, and plugs. Valves utilized throughout the industry must meet rigorous quality and production standards. Southern California Valve has earned its API 6A, API 6D, ISO: 9001, CE-PED, and CRN certifications while operating under the API Q1 Quality Management System.

With years of dedication and commitment to quality, design, and service, Southern California Valve has grown to be one of the premier valve manufacturers in the industry with the largest inventory of high pressure ball, gate, and check valves on the West Coast. We pride ourselves on our high quality products, timely delivery capabilities, and competitive prices.

On behalf of all of the members at Southern California Valve, we thank you for the opportunity to earn your business.

Sincerely,

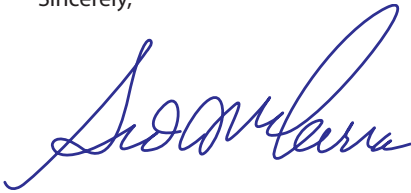

Sid McCarra
President - Texas Operations
Southern California Valve

Since 1972, Southern California Valve has been committed to providing quality flow control products to the Power, Paper & Pulp, Oil & Gas, and Petro Chemical industries.

As one of the largest valve manufacturers on the West Coast, Southern California Valve's reputation is unparalleled for producing high quality commodity and specialty valves. Products range in sizes 1/4" - 84", in pressure classes from 150# - 2500# and are backed by timely deliveries and competitive prices.

Call SCV today at (281)482-4728 for all your valve needs or visit us on the web @ www.scvvalve.com.

**SALES, PROJECTS, ENGINEERING,
MANUFACTURING, & WAREHOUSING**

3521 FM 646 Rd. North
Santa Fe, TX 77510
Phone: (281) 482-4728
Fax: (281) 482-9728

Hours: 8:00 a.m. to 5:00 p.m. Central Standard
Email: sales@scvvalve.com

**MANUFACTURING &
WAREHOUSING**

13903 Maryton Ave.
Santa Fe Springs, CA 90670
Phone: (562) 404-2246
Toll Free: (800) 554-6421

Fax: (562) 404-2836
Hours: 8:00 a.m. to 5:00 p.m. Pacific



Southern California Valve

(281) 482-4728 • www.scvvalve.com