

WALWORTH®
Since 1842

TRUNNION MOUNTED BALL
CATALOG



www.walworthvalves.com

INDEX

INTRODUCTION

WALWORTH COMPANY	4
WALWORTH ENGINEERING CONTROL	5
WALWORTH QUALITY SYSTEMS.....	5
QUALITY CONTROL EQUIPMENT.....	9

API 6D TRUNNION MOUNTED BALL VALVES

WALWORTH TRUNNION BALL VALVES.....	11
BODY MATERIALS AND TRIM ARRANGEMENTS	12
META-TO-METAL SOFT SEAT COMPARISSON	13
SAFETY FEATURES	14
TRUNNION MOUNTED BALL VALVE BOLTED BODY, CLASS 150.....	17
TRUNNION MOUNTED BALL VALVE BOLTED BODY, CLASS 300.....	22
TRUNNION MOUNTED BALL VALVE BOLTED BODY, CLASS 600.....	27
TRUNNION MOUNTED BALL VALVE BOLTED BODY, CLASS 900.....	32
TRUNNION MOUNTED BALL VALVE BOLTED BODY, CLASS 1500.....	37
TRUNNION MOUNTED BALL VALVE BOLTED BODY, CLASS 2500.....	42
TRUNNION MOUNTED BALL VALVE WELDED BODY, CLASS 150.....	47
TRUNNION MOUNTED BALL VALVE WELDED BODY, CLASS 300.....	52
TRUNNION MOUNTED BALL VALVE WELDED BODY, CLASS 600.....	57
TRUNNION MOUNTED BALL VALVE WELDED BODY, CLASS 900.....	62
TRUNNION MOUNTED BALL VALVE WELDED BODY, CLASS 1500.....	67
TRUNNION MOUNTED BALL VALVE WELDED BODY, CLASS 2500.....	73
TECHNICAL INFO, STEM EXTENSIONS & CONNECTIONS.....	76
TECHNICAL INFO, TYPE OF OPERATIONS	76
TECHNICAL INFO, FULL AND REDUCED BORE	77
TECHNICAL INFO, GLAND FLANGE & BELLEVILLE WASHERS.....	77
PRESSURE-TEMPERATURE RATINGS	78
DESIGN BASICS	80
HOW TO ORDER.....	81
GENERAL TERMS & CONDITIONS	82



YARMOUTH RESEARCH AND TECHNOLOGY



WALWORTH COMPANY

The WALWORTH Company is one of the world's most dominant and comprehensive industrial valve manufacturers. Founded in 1842 by James Walworth, the Company has consistently dedicated itself to the design and manufacture of an array of valves exceptionally suited for the world's fluid control sector. We satisfy all end use industries and comprehensive customer requirements by adhering to the most demanding quality standards.

WALWORTH relies on its broad experience in supplying valves to the petrochemical, oil & gas, petroleum, power generation, pulp and paper, cryogenic and geothermal industries, among other.

Over the years, the Company has produced more than 40,000 different types of products and serves as a global supplier to varied markets utilizing the expertise of over 500 trained employees.

Our manufacturing system includes utilization of Company-directed raw material warehouses; up-to-date specialized machinery; welding processes such as SMAW, GMAW, SAW, PAW; assembly testing for low pressure, high pressure, at low or high temperature; painting processes; crating and shipment.

With Company-directed facilities and stocks in the United States and Mexico, WALWORTH is capable of providing the world's most comprehensive industrial valve line to the North American, Central American, South American, European and African markets. WALWORTH is proud to meet the ultimate demands of customer satisfaction, especially in quality, cost, effectiveness and services in all parts of the world.



WALWORTH VALUES

MISSION

To satisfy the needs of Customers in terms of quality and service and comply with expectations of employees, suppliers and share holders.

VISION

To maintain our good reputation in terms of service, delivery and quality which has been the main goal during more than 167 years, positioning the WALWORTH brand as a reliable Company in the market that continues developing new products according to the needs of the industry in terms of technology, environment and quality.

WALWORTH also offers a complete service that includes technical support and personal attention in order to ensure the confidence of our Customers.

WALWORTH ENGINEERING CONTROL

WALWORTH products are manufactured following strictly the most recognized international standards all over the world, such as API, ANSI, ASME, ASTM, MSS, NACE, AWWA, BSI, CSA, among others. Our Engineering team is always studying the new updates of these standards to incorporate any changes that may affect the design, regulations or performance of our products, being leaders in the new developments achieved.

Design is made using the most advanced technology and equipment, using finite elements and CAD system programs to ensure the proper assembly and performance of products since the concept, calculation and detailed drawings for manufacturing. WALWORTH is a leader in the development of new products according to valve market current needs.



WALWORTH QUALITY SYSTEM

Throughout the years, WALWORTH has developed its Quality System which is an integral part of our manufacturing policy. Our primary goal is to provide products that meet and exceed market standards. In this sense, WALWORTH is an ISO-9001 Audited and Certified Company that has achieved major certifications worldwide. Our system consists of rigorous quality control as well as the selection of raw materials from approved vendors. Control over our manufacturing process is vital. Serial numbers allow WALWORTH to monitor and trace fabrication processes and component materials.



Certificate API-6D No. 6D-0097 issued by American Petroleum Institute to apply on Gate valves, Plug valves, Ball valves and Check valves manufactured in accordance with API-6D specification.

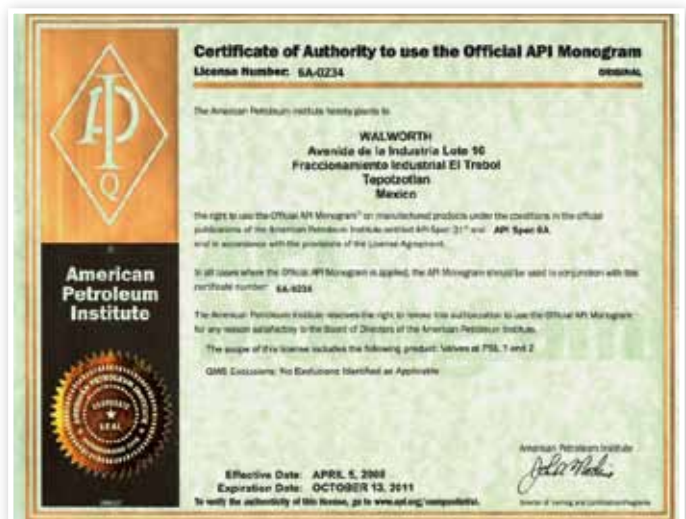

Certificate API-6A No. 6A-0234 from American Petroleum Institute to apply on valves at PSI, 1 through 4.



Certificate ISO-9001 No. 038 issued by American Petroleum Institute since April 1999.



Certificate as per PED 97/23/EC Module H to stamp CE products.



TA Luft Certificate (Fugitive Emission) Approval ISO-5211 Top Flange, Anti-Static Device.



Certificate of Reliable Supplier No. 199/07 issued by CFE in accordance with ISO-9001 Quality Assurance System.



Certificate NMX-CC-9001 (Mexican Standards ISO-9001) No. 0552/2007 issued by PEMEX in accordance with ISO-9001 Quality Assurance System.

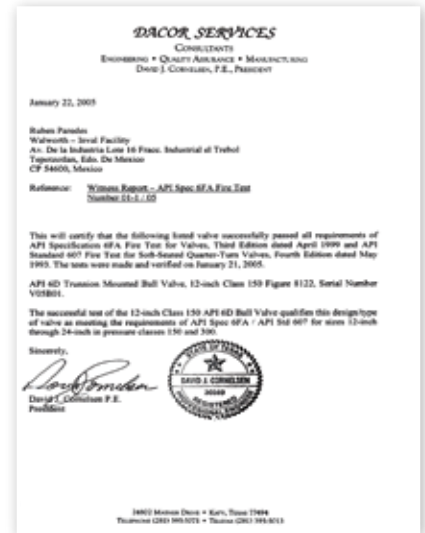

Fire Test Certificate No. 04/04 in accordance with API-6FA and API Standard API-607 for Trunion Ball Valves in accordance with API-6D.



Certificates of Ultra Low Fugitive Emissions No. 20985-3, 8 & 16 in accordance with ISO-15848-1 "Industrial Valves" - Measurement, Test and Qualification Procedures for Fugitive Emissions "Part 1: Classification System and Qualification Procedures for Type Testing of Valves".





Emissions after 500 cycles at ambient and 350 °F issued by Yarmouth Research and Technology Lab for 3 inch Class 300 Gate Valve After 500 cycles the measurement result was less than 50 ppm.



Certificate API-594 No. 594-0007 issued by American Petroleum Institute to apply on Check Valves-Type A; Check Valves Type B manufactured in accordance with API-594 specification.



Emissions after 500 cycles at ambient and 350 °F issued by Yarmouth Research and Technology Lab for 8 inch Class 300 Gate Valve After 500 cycles the measurement result was less than 50 ppm.



API-600 Certificate No. 600-0109 issued by American Petroleum Institute to apply on Bolted Bonnet Steel Gate Valves manufactured in accordance with API-600 specification.



Emissions after 500 cycles at ambient and 350 °F issued by Yarmouth Research and Technology Lab for 8 inch Class 300 Gate Valve After 500 cycles the measurement result was less than 50 ppm.



API-602 Certificate No. 602-0024 issued by American Petroleum Institute to apply on Compact Steel Gate Valves, Compact Steel Globe Valves, and Compact Steel Check Valves manufactured in accordance with API-602 specification.

QUALITY CONTROL EQUIPMENT

In order to assure that WALWORTH products comply with international-quality standards, in-house equipments is kept for monitoring control, some of which includes:

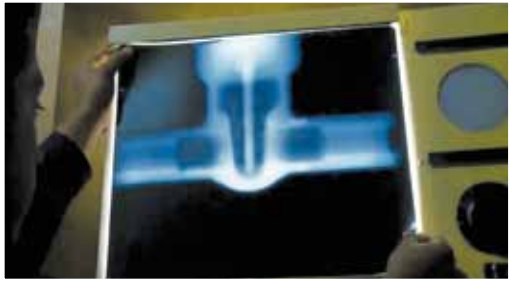

X-Ray Examination Equipment. WALWORTH has its own Ir-92 source in-house for the radiographic examination (RT) of castings from 0.100" up to 2 1/2" wall thickness to verify the soundness of the casting raw material.

PMI Equipment. New generation of Positive Material Identification Equipment gives WALWORTH the capability to perform quick chemical analysis on incoming raw materials and on pieces after assembly to certify that materials used were produced and assembled in accordance with both WALWORTH'S and the Customer's specifications.



Magnetic Particle Test. During random testing of standard products or when a Customer requests MT Certification, WALWORTH has Magnetic Particle Test Equipment to perform on ferromagnetic materials.

Penetrant Test Examination. WALWORTH has the personnel and materials necessary to perform PT examination by solvent removable or water washable techniques. The NDT personnel are ASNT Certified.



Test Loop. A complete Laboratory Test loop exists for design validation of WALWORTH products, performing the test at maximum design pressure and cycling the valves from 3000 to 5000 cycles. The test requires longer than four months for completion.

Pressure Gradient Test Loop. This test exposes Plug valves to the extremes of both positive and negative pressure gradients to verify that the plug in a balanced plug design will prevent lock-up in the body.





Metrology Laboratory. WALWORTH developed a calibration and/or verification system in all the equipment used in its facilities to ensure the traceability of measurements to international standards. In this way, WALWORTH gets measurement control of its products to comply with international standards.

Fire Test Facilities. Facilities to perform fire test in accordance to API requirements. The test exposes the valve to a fire flame at 1400 to 1800 °F (761 to 980 °C) to verify proper seal of the valve.



Low Fugitive Emissions Test. When a Customer requires low fugitive emissions certification. The Lab has its own LFE Test Equipment capable of measuring less than 20 ppm in either static and/or mechanical conditions at ambient temperature or thermal cycle operations.

Ultrasonic Testing Equipment. Using ultrasonic techniques, we can detect sub surface flaws in materials and evaluate castings and forgings that cannot be radiographed. In addition, we utilize these techniques to measure the wall thickness of castings and forgings.



Tensile Test Equipment. To verify the mechanical properties of materials used for manufacturing, WALWORTH tests samples on a random basis even though we receive MTR's from our suppliers and foundries.

Hardness Test Equipments. Either lab or shop test, WALWORTH use hardness tester equipments as Rockwell B, C Brinell or Vickers to check compliance against specifications.



WALWORTH TRUNNION MOUNTED BALL VALVES

EXTRACTION & REFINING OF CRUDE OIL

Trunnion Mounted Ball Valves are primarily used but not limited to the oil & gas industry to provide reliable block and bleed service. WALWORTH Trunnion Mounted Ball Valve Design features provide solutions for any application within the extraction & refining of crude oil market. These features ensure durability, safety & long term performance on and off shore. Walworth engineering product development is subject to API 6D, ISO 14313, ASME B16.34, ASME VIII. ANSI 150 to 2500 pressure class are available and do come in reduced and full port; the latter facilitates the running of cleaning tools through conduit, avoids turbulence & decrements in pressure. WALWORTH offers an array of standard materials for body and interiors e.g.

1. Carbon Steels (A 105 - WCB).
2. Low Carbon Steels (LF2, LF3 - LCB, LCC).
3. Stainless Steels (F316, F347 - CF8M, CF8C).
4. Duplex Stainless Steel (F51 - CD3MN).
5. Super Duplex Stainless Steel (F55 - CD3MWCuN).

Special materials are suggested as unique conditions require.

WALWORTH Interiors Trim Arrangement includes materials from tables listed in API-6D. High Tensile Strength materials such as 17-4pH, duplex & super duplex steels (UNS S31803 or UNS S32750), high nickel alloys (Monel, Inconel, Incoloy, Hastelloy.) are also available. Soft Seat Elastomer & Thermoplastic, (Viton ,PTFE, NYLON, DEVLON, PEEK) special inserts are also available.

Design Features

- Trunnion Mounted Valves in accordance with API-6D
- Manufactured with forged materials to achieve uniform fine grain structure and toughness.
- Bolted or welded body
- Hardfacing coating: ENP, stellite 6 & tungsten carbide
- Internal cladding available: carbon steel body + inconel 625
- Obeys to API-6FA, API-607 fire tests
- Through conduit, full bore, negligible pressure drop, no turbulence, suitable for pigging operations (reduced port upon request).
- Flange dimensions in accordance ASME B16.5 for valves up to 24" in nominal diameter.
- Flange dimensions in accordance MSS-SP-44, ASME/ANSI B16.47 series A or B for valves over 26" in nominal diameter.
- Manual (lever or gear operator), electric, hydraulic & pneumatic actuation.
- Double block and bleed service that comes with bleed plug to body cavity.
- Bi-directional flow
- Anti-static device
- Spring loaded seats
- Blow out proof system
- NACE service subject to MR-01-75 or MR-01-03
- Test in accordance API-6D
- Special constructions available for high and low temperature



Product Range

Type	Size	Pressure Class as per ASME/ANSI B16.34	Ends
Trunnion ball valve, bolted body	2" a 60"	150, 300, 600, 900, 1500 & 2500#	RF, RTJ o BW
Trunnion ball valve, welded body	2" a 60"	150, 300, 600, 900, 1500 & 2500#	RF, RTJ o BW

BODY MATERIALS & TRIM ARRANGEMENTS

STANDARD MATERIALS. BODY AND ENDS MATERIALS

Material ASTM	Carbon Steel General & Sour Service		Carbon Steel Low temperature		Low Alloy High Temperature		Stainless Steel Corrosion Resistant		Duplex SS Corrosion Resistant	
	Casting	WCB	WCC	LCB	LCC	WC6	C12A	CF8M	CF3M	UNS S31803
Forged	A105N		LF2		F11	F91	F316	F316L	F51	F44

Note: Other Material are available

BALL MATERIALS FOR SOFT SEATS (TABLE A)

CLASE	2" a 8"	10" a 16"	18" a 24"	26" a 48"
150	SS 316	SS 316	SS 316	SS 316
300	SS 316	SS 316	SS 316	SS 316
600	SS 316	SS 316	SS 316	F51 / 17-4PH
900	F51 / 17-4PH	F51 / 17-4PH	F51 / 17-4PH	F51 / 17-4PH
1500	F51 / 17-4PH	F51 / 17-4PH	F51 / 17-4PH	F51 / 17-4PH
2500	F51 / 17-4PH	F51 / 17-4PH	F51 / 17-4PH	F51 / 17-4PH

ENP: 0.003" (75 µm) Electroless Nickel Plated (ENP), on all external and internal surfaces

Notes: (1).- SS 316+0.003" ENP Stem for Class 150,300 & 600, 17-4PH+0.003" ENP Stem for Class 900,1500 & 2500

TRIM MATERIALS FOR SOFT SEATS ARRANGEMENT

TRIM	Ball	Stem	Trunnion	Seat Rings	Back Seat Ring	Seat Insert	
T1	STD	A105+ENP	AISI 4140+ENP / A182 F6	AISI 4140+ENP / A182 F6	A105+ENP	A105+ENP	See Table B
T2	SS 410	A182 F6A+ENP	A182 F6A	A182 F6A	A182 F6A	A182 F6A	See Table B
T3	SS 316	See Table A (1)	A182 F316+ENP (1)	A182 F316+ENP (1)	A182 F316	A182 F316	See Table B
T4	SS 304	See Table A (1)	A182 F316+ENP (1)	A182 F316+ENP (1)	A182 F316	A182 F316	See Table B

ENP: 0.003" (75 µm) Electroless Nickel Plated (ENP), on all external and internal surfaces

Notes: (1).- SS 316+0.003" ENP Stem for Class 150,300 & 600, 17-4PH+0.003" ENP Stem for Class 900,1500 & 2500

TRIM MATERIALS FOR METAL-TO-METAL SEATS ARRANGEMENT

TRIM	Ball	Stem	Trunnion	Seat Rings	Back Seat Ring	
T5	SS 410+TC	A105+TC / A182 F6A+TC	AISI 4140+TC / A182 F6+TC	AISI 4140+TC / A182 F6+TC	A182 F6A+TC	A182 F6A
T6	SS 316+TC	A182 F316+TC / 17-4PH+TC	17-4PH	17-4PH	A182 F316+TC / 17-4PH+TC	A182 F316
T7	SS 316 + ST #6	A182 F316+ST#6 / 17-4PH+ST#6	17-4PH	17-4PH	A182 F316+ST#6 / 17-4PH+ST#6	A182 F316

TC 0.008" (200 µm) Tungsten Carbide Hardfacing (TC), on all Seal surfaces

ST #6 0.010" (250 µm) Stellite #6 Hardfacing (TC), on all Seal surfaces

SOFT SEAT INSERT MATERIALS (TABLE B)

CLASE	2" a 12"	14" a 16"	18" a 24"	26" a 48"
150	RPTFE	NYLON	NYLON	MOLON
300	RPTFE	NYLON	NYLON	MOLON
600	NYLON OR MOLON	NYLON OR MOLON	MOLON	MOLON
900	MOLON OR DEVLON	MOLON OR DEVLON	MOLON OR DEVLON	MOLON O DEVLON
1500	MOLON OR DEVLON	MOLON OR DEVLON	MOLON OR DEVLON	MOLON OR PEEK
2500	PEEK			

METAL-TO-METAL SOFT SEAT COMPARISON

SOFT SEATS ARRANGEMENT

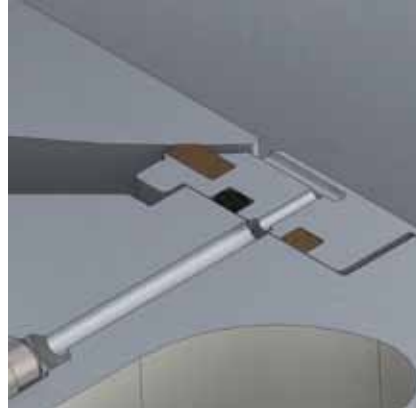

SOFT SEAT INSERTS

Stringent limitations on ball valve designing along with operating conditions have resulted in the use of several thermoplastic materials to meet the required operating range for ball valve seat inserts thus, WALWORTH offers soft seats such as RPTFE, NYLON, DEVLON, PEEK ETC to guarantee zero leakage at low and high pressures at different temperatures these can be used for several services in any industry, they are also preferred and supplied to Oil and Gas producers. Soft seat inserts reduce friction which result in less torque when operating the valve.

FIRE SAFE DESIGN

Internal leakage prevention: whenever Seat Inserts and O'rings worn off or get damaged the line pressure collectively with Live-Load set of springs push the metal seat towards the ball surface allowing the component to achieve closure these shut off the line stopping the flow preventing internal leakage. WALWORTH VALVES are fitted with Graphite packing which avoids any leakage between valve body and Seat Ring.

METAL-TO-METAL SEATS ARRANGEMENT

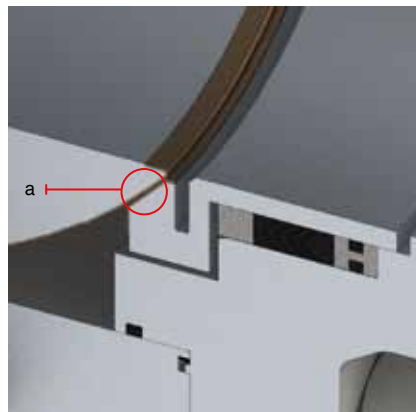
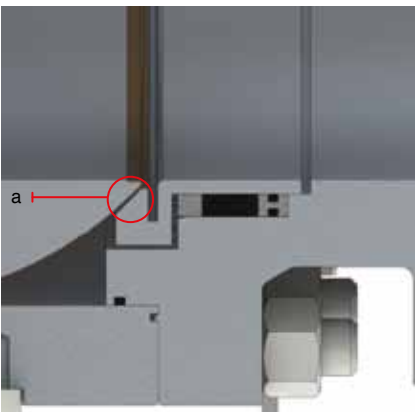

Design is suitable for tough applications; as a result WALWORTH offers Tungsten Carbide or Stellite 6 coatings(a) applied on both the seat and obturator ensuring appropriate hardness for each of the two components, all this is achieved with the aid of the latest technologies that allow our product to withstand:

- High temperature & abrasive services
- Harsh, hazardous & corrosive fluids
- Coal gasification
- Slurry fluids
- Sub sea services
- Produced water (brine) services

WALWORTH TRUNNION MOUNTED BALL VALVES

SAFETY FEATURES

DYNAMIC SEAT RINGS

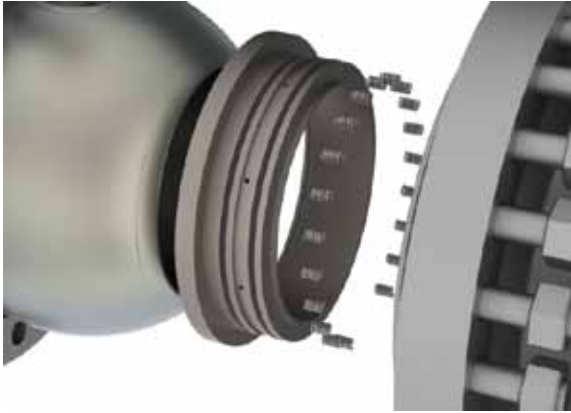

Spring loaded seats achieve low operating torque at different positions under high working pressures. Each seat ring is placed at each end of the ball in a way that the components achieve alignment whenever the valve is fully opened; the rings are pushed towards the obturator by a set of coil springs which ensure appropriate sealing at low pressure before piston action effect takes place.

WALWORTH seat arrangement has been designed to meet what is called a piston effect: As pressure increases, the seat differential area creates a piston effect that pushes the seat towards the ball surface that makes the mechanism attaining tight seal (upstream seat), such action reverses automatically as the pressure increases, thus, overpressure between upstream and downstream seats (body cavity) could be released.

WALWORTH is able to manufacture special Trunnion Mounted Ball Valves with seat arrangements that allow double piston effect which make use of the downstream seat acting as a secondary seal. Relieving over pressure built up in the body cavity shall be achieved by means of an extra valve.

EMERGENCY SHUT OFF INJECTION GREASE FITTING FOR STEM AND SEATS AREA

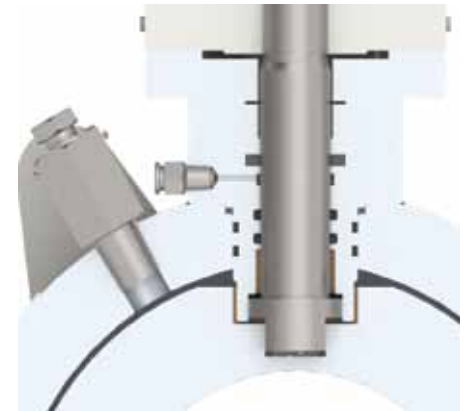
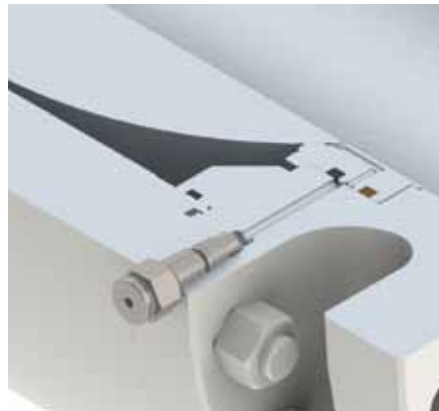
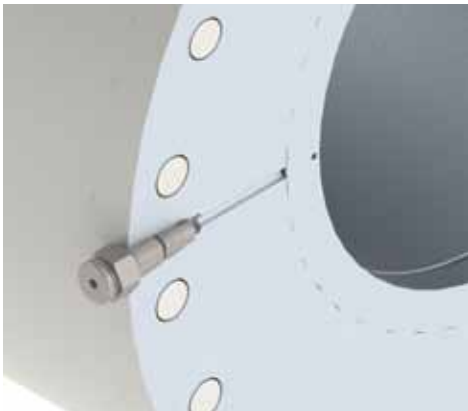

WALWORTH offers an optional feature that consists in fitting an emergency seat which enables the injection of a viscous sealant backup acting as a security agent in the event of any failure suffered by the insert; this system sustains temporary seal until maintenance takes place. The sealant is injected into the valve through a plug insert, which passes through a specific and specially designed groove to obtain an efficient auxiliary seal. This fitting acts as a ball check valve only allowing the sealant to enter and no other things of excess to come out. An injection fitting is another safety feature that allows the stem to restore integrity in the event of any failure around the sealing area.

WALWORTH TRUNNION MOUNTED BALL VALVES

SAFETY FEATURES

DOUBLE BLOCK & BLEED (DBB)

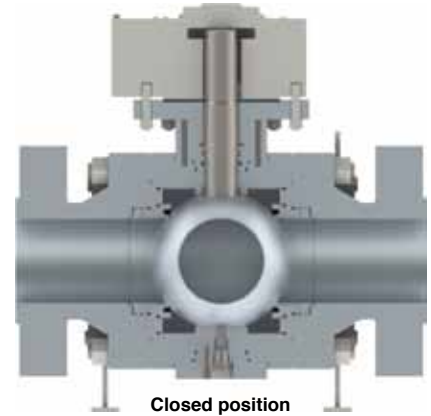
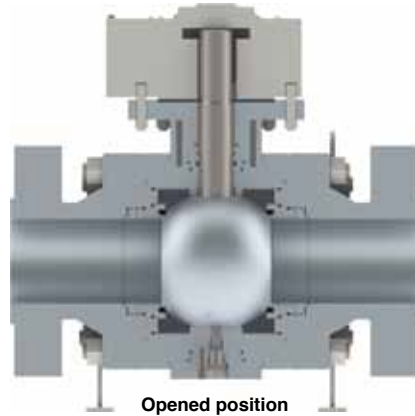
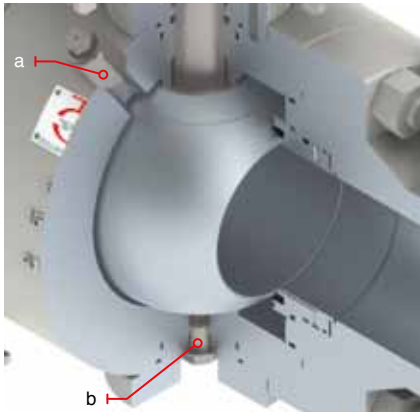

WALWORTH Trunnion - Mounted ball valves have been designed with two seating surfaces (Upstream & Downstream Seats), each of them in the close position achieve sealing against pressure coming from a single source. Anti-blow-out(a) vent & drain plug(b) allow Bi-Directional Valves to vent and drain the body cavity in both open and closed positions, this feature helps to de-pressurize the line downstream to open up and work on it.

BLOW OUT PROOF STEM DESIGN & ANTISTATIC STRUCTURE

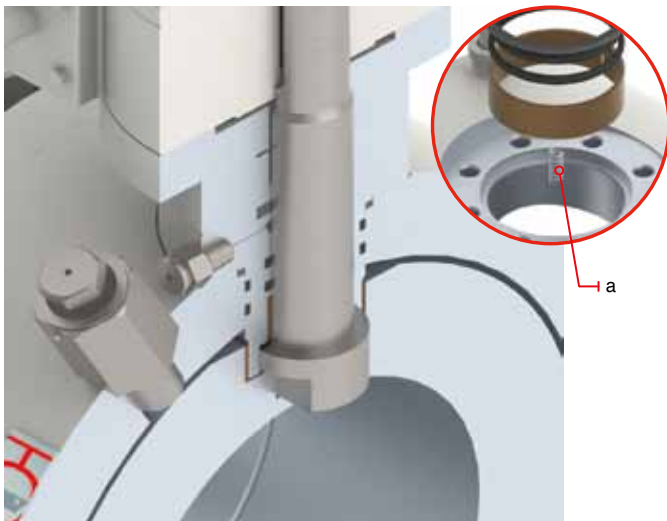

BODY SEALING

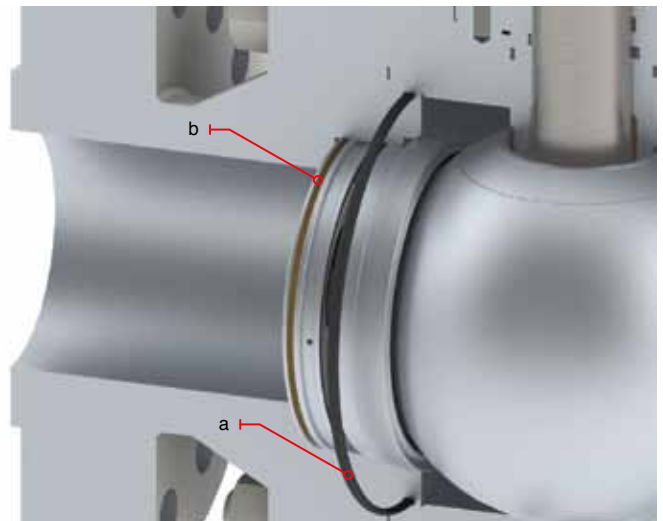

To reinforce safety, WALWORTH have fitted the product with a T-Shaped blowout proof stem back seat that significantly extends stem seal life and prevents it to come out from the body structure. It also includes an antistatic device(a) that lowers coefficient of friction between seat and ball when operating the valve. Friction could cause electrostatic charges (sparks) that could cause fire when mixing with fluid. Leakage from the valve stem is prevented with the aid of two O'rings and a Gasket that work together with the graphite packing.

Double sealing action of O'rings(a) and graphite filled gasket(b) in the static joints of the body components ensure zero leakage.

WALWORTH TRUNNION MOUNTED BALL VALVES

SAFETY FEATURES

UPPER & LOWER TRUNNIONS

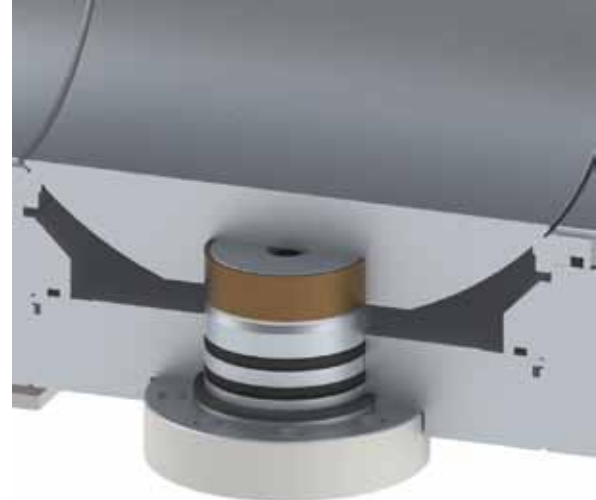
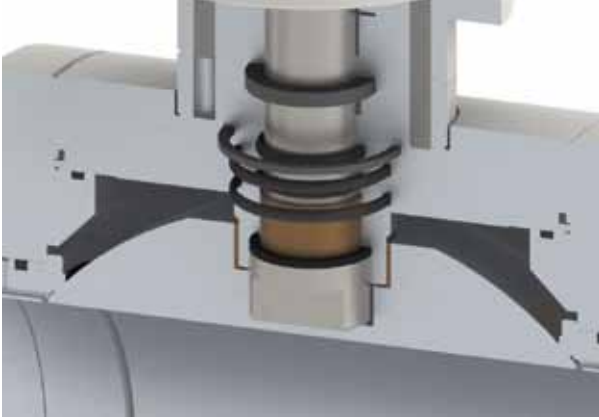

The ball is held by two cylindrical protrusions that anchor the sphere from top and bottom, their main function is to avoid the ball moving off the pivot axis making it easy to operate.

THROUGH CONDUIT



Whenever a pipe line requires maintenance or inspection, the use of gauges or pigs is necessary. WALWORTH full port ball valve eases the passing of such devices without the need to shut down the flow of the fluid.

TRUNNION MOUNTED BALL VALVE BOLTED BODY, CLASS 150

Trunnion Mounted Ball Valves are designed and manufactured in conformance with API 6D, ISO 14313, ASME B16.34, API 6FA, API 607 & NACE MR01-75.

Design Features

- Sizes NPS (DN): 2”(50mm) to 48”(1200mm)
- ASME Class: 150 #
- Temperature ratings: -50°C to 121°C (standard design)
- Design: API 6D/ISO14313, ASME B16.34
- Face to face, end to end: API 6D, ASME B16.10
- Butt weld ends: ASME B16.25
- Test: API 6D, API 598, ISO 5208
- Fire test: API 6FA, BS6755, API607
- Sour environments: NACE MR-01-75
- Seals area overlay: Upon request

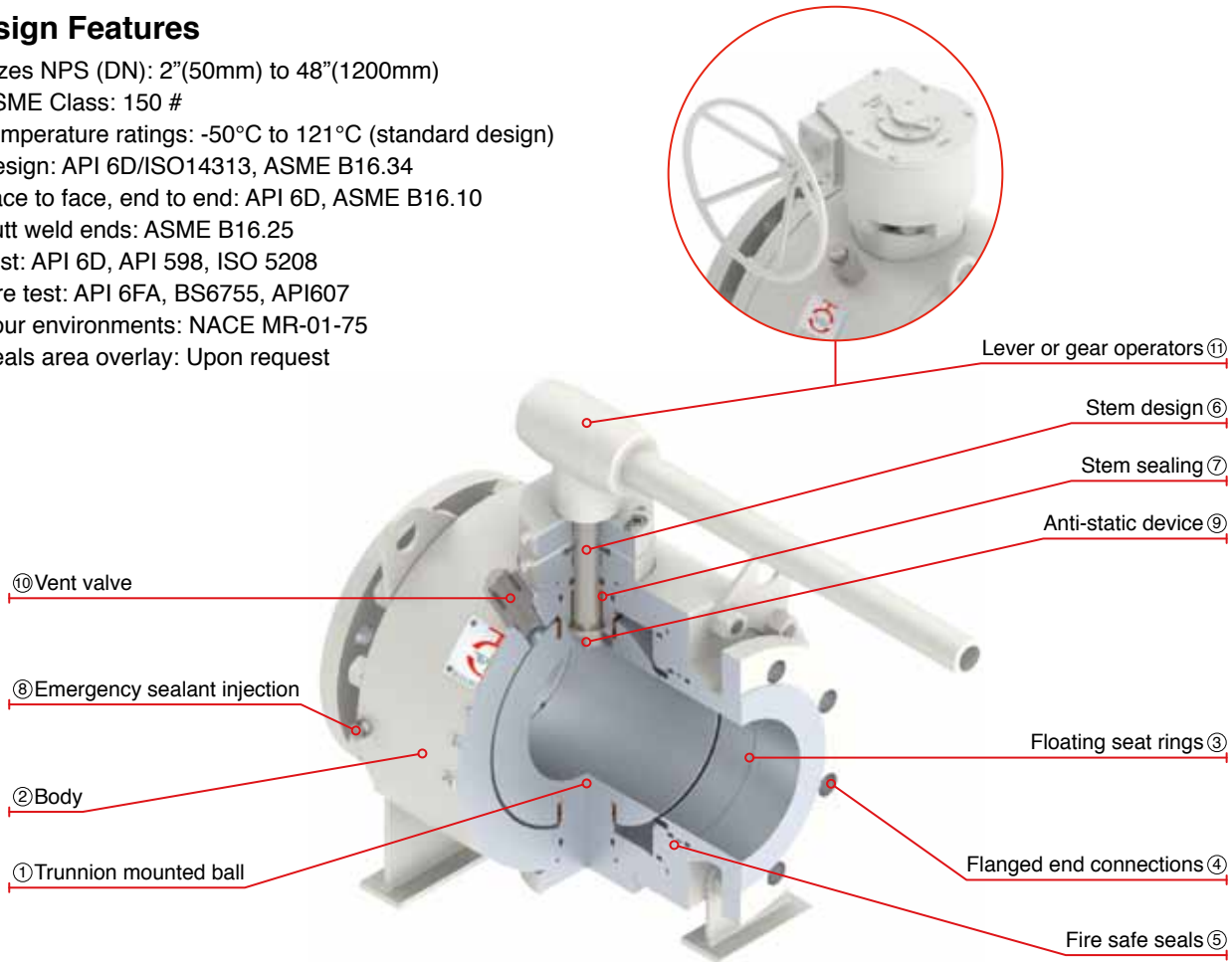

- ① Trunnion mounted ball: For all sizes & pressure ratings. The ball is fixed by an upper & lower trunnion, seat rings are dynamic which will move freely along the horizontal axis.
- ② Body. Three piece forged steel body for easy disassembly on site. Small cavities between body, seats & ball minimize the quantity of fluid that could get stored in that hollow space.
- ③ Floating seat rings. Two independent dynamic seat rings attain Bi-Directional closure of the valve these Seat. Rings are spring loaded that achieve tight shut-off at considerable low differential pressure.
- ④ Flanged ends connections. Forged steel RF or RTJ connections according to ASME B16.5 up to 24” and ASME B16.47 Series A for 26” & larger.
- ⑤ Fire safe seals: Fire safe design prevents leakage when the elastomeric seals are exposed to very high temperatures.
- ⑥ Stem design: Bottom entry anti blow out stem is made of one piece which is held up by the valve body. It has been design to avoid any possible projection due to hazardous conditions.
- ⑦ Stem sealing: Accurate machining process together with electro less nickel plated (ENP) coating control the hardness amongst stem, metallic components & double O’rings, these are supported by a secondary graphite seal which ensure reliable operation at high levels of sealing integrity when operating the valve.
- ⑧ Seats & stem emergency sealant injection (6” & Larges): Valves are supplied with emergency sealant Injectors located between the double O’ring arrangement of the seat assembly & stem seal area. A highly viscous sealant is injected through these fittings to restore closure integrity.*Whenever the valve lifetime has ended or if any of the seats get damaged, the emergency sealant injection system may temporarily be used to achieve tightness before maintenance takes place.
- ⑨ Antistatic device: An inconel spring is placed between body, ball and stem to prevent static continuity.
- ⑩ Block & bleed: Double block & bleed is achieved with the valve in two positions either fully closed or fully opened.
- ⑪ Lever handle: 6” & larger valves supplied with gear operator.

TRUNNION MOUNTED BALL VALVE BOLTED BODY, CLASS 150 (LEVER OPERATED)

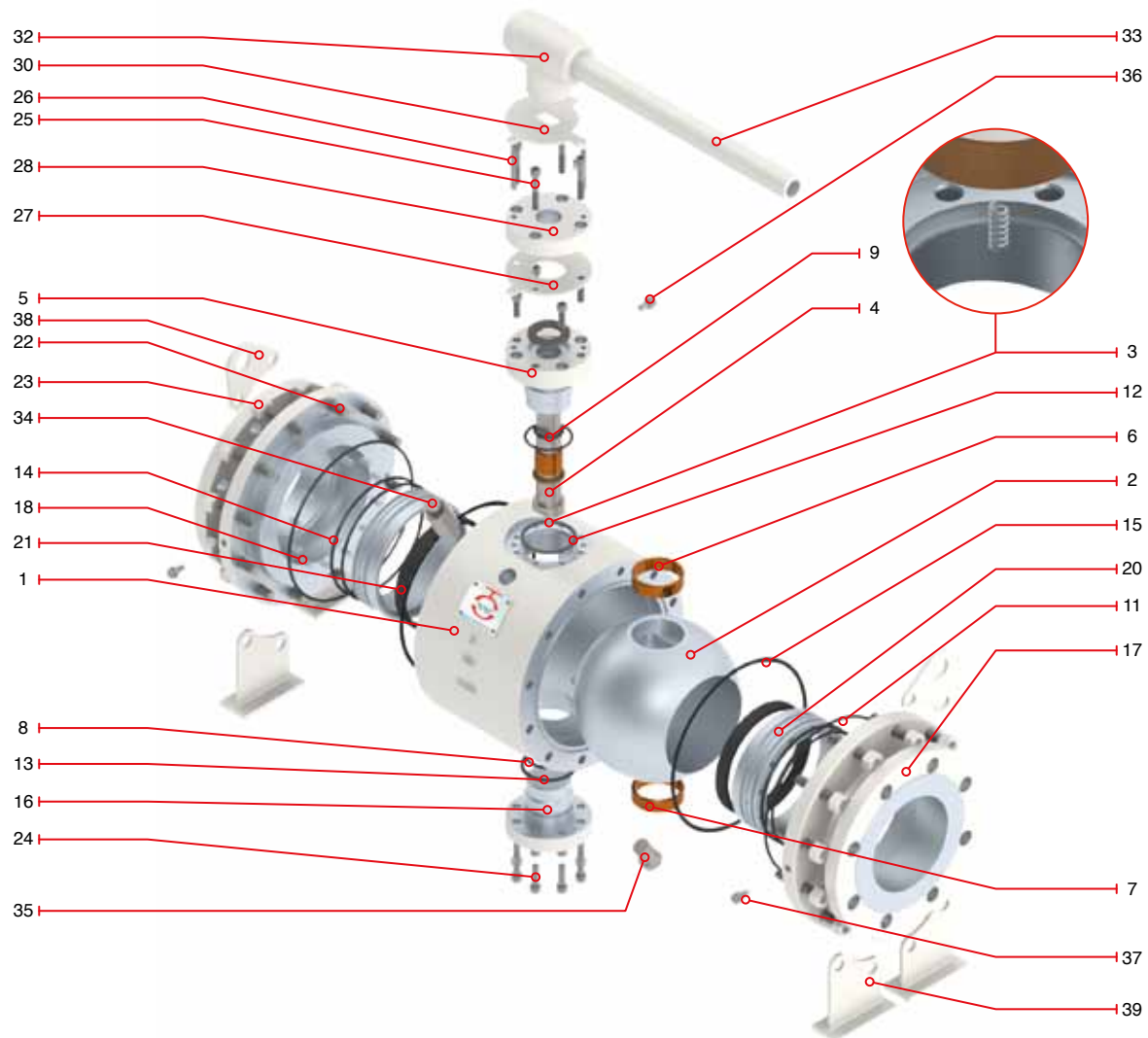

Regular Bill of Materials

No.	Description	ASTM Materials	No.	Description	ASTM Materials
1	Body	ASTM A105N	21	Seat insert	RPTFE
2	Ball	ASTM A105+75µm ENP / AISI 410	22	Stud	ASTM A193 B7M
3	Antistatic spring	INCONEL X-750	23	Nut	ASTM A194 2HM
4	Stem	AISI 4140+75µm ENP / AISI 410	24	Bottom socket screw	ASTM A193 B7M
5	Trunnion / bonnet	AISI 4140+75µm ENP	25	Top socket screw	ASTM A193 B7M
6	Upper bearing	C.S.+ PTFE LINING	26	Pin	Carbon Steel
7	Lower bearing	C.S.+ PTFE LINING	27	Locking device	A36
8	Lower O'ring	Viton	28	Packing gland flange	ASTM A216 WCB / A105
9	Stem O'ring	Viton	29	Hex. Bolt *	ASTM A193 B7M
10	On seat O'ring *	Viton	30	Stop plate	A36
11	Back up O'ring	Viton	31	Retainer *	AISI 1070
12	Upper fire safe gasket	Graphite	32	Handle nut	ASTM A216 WCB
13	Lower fire safe gasket	Graphite	33	Handle	ASTM A53
14	Fire safe gasket On seat	Graphite	34	Vent valve	Carbon Steel
15	Ends flange fire safe gasket	Graphite	35	Drain plug	Carbon Steel
16	Lower trunnion	AISI 4140+75µm ENP / AISI 410	36	Stem grease fitting	AISI 4140
17	Flanged ends	A105N	37	Grease fitting	AISI 4140
18	Seat spring	INCONEL X-750	38	Lifting lug	A36
19	Back up seat ring *	ASTM A105+75µm ENP / AISI 410	39	Support leg	A36
20	Seat ring	ASTM A105+75µm ENP / AISI 410			

* Not shown

TRUNNION MOUNTED BALL VALVE BOLTED BODY, CLASS 150 (LEVER OPERATED)

Design Features

- Sizes NPS (DN): 2"(50mm) to 48"(1200mm)
- ASME Class: 150 #
- Temperature ratings: -50°C to 121°C (standard design)
- Design: API 6D/ISO14313, ASME B16.34
- Face to face, end to end: API 6D, ASME B16.10
- Butt weld ends: ASME B16.25
- Test: API 6D, API 598, ISO 5208
- Fire test: API 6FA, BS6755, API607
- Sour environments: NACE MR-01-75
- Seals area overlay: Upon request



Catalog Figure No.	Type of Ends
8112	Raised Face (RF)
8113	Ring Type Joint (RTJ)
8114	Buttweld (WE)

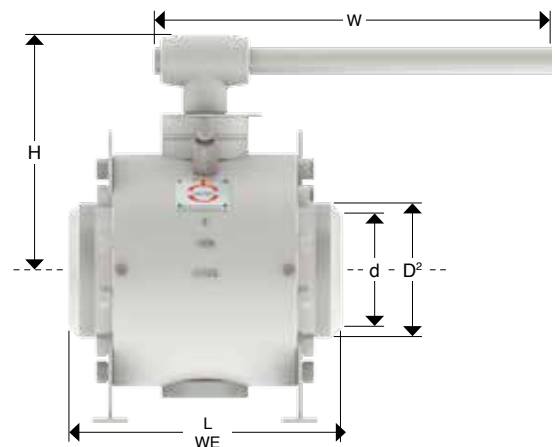
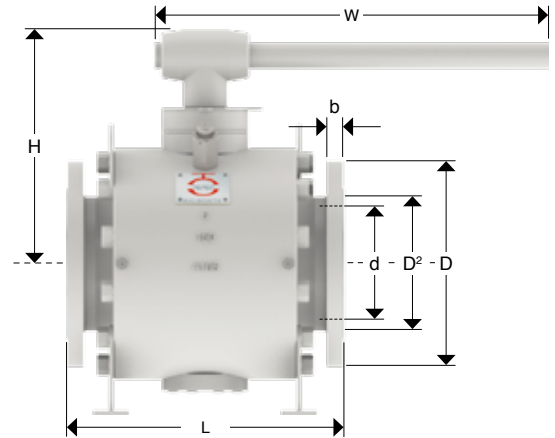

Dimensions and Weights

D Nominal Diameter	mm in	50 2"	65 2 ½"	80 3"	100 4"
d	mm in	49 1.93	62 2.44	74 2.91	100 3.94
D	mm in	150 5.98	180 7	190 7.48	230 9.02
D2	mm in	92 3.62	105 4.13	127 5	157 6.18
b	mm in	16 0.63	18 0.71	19 0.75	24 0.94
L	mm in	178 7	191 7.48	203 8	229 9.02
L (WE)	mm in	216 8,5	241 9,48	283 11,14	305 12
H	mm in	172 6.79	210 8.28	241 9.50	275 10.84
ØW	mm in	*350 13.78	*350 13.78	*400 15.75	*450 17.72
Weight (RF - RTJ)	kg Lb	20 44	32 70	43 95	65 143

Key Parameters

Code	Name
d	Bore diameter
D	Flange diameter
D2	Raised face diameter
b	Flange thickness
L	Raised face and ring type joint face to face
L (WE)	Welded end face to face
H	Height
ØW	Handwheel diameter
Weight	Weight

TRUNNION MOUNTED BALL VALVE BOLTED BODY, CLASS 150 (GEAR OPERATED)

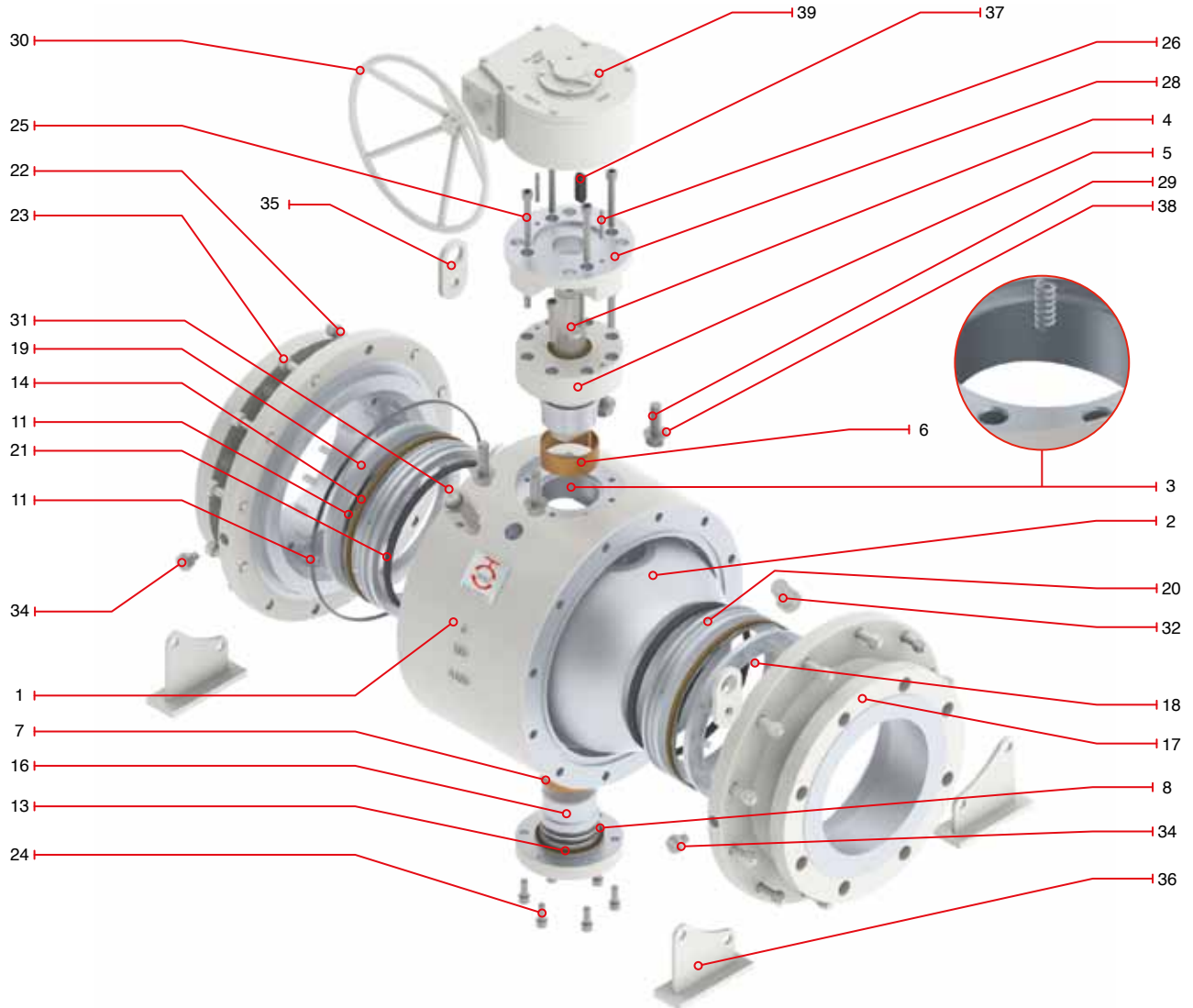

Regular Bill of Materials

No.	Description	ASTM Materials	No.	Description	ASTM Materials
1	Body	ASTM A105N	21	Seat insert	RPTFE
2	Ball	ASTM A105+75µm ENP / AISI 410	22	Stud	ASTM A193 B7M
3	Antistatic spring	INCONEL X-750	23	Nut	ASTM A194 2HM
4	Stem	AISI 4140+75µm ENP / AISI 410	24	Bottom socket screw	ASTM A193 B7M
5	Trunnion / bonnet	AISI 4140+75µm ENP	25	Top socket screw	ASTM A193 B7M
6	Upper bearing	C.S.+ PTFE LINING	26	Pin	ASTM A276 T410
7	Lower Bearing	C.S.+ PTFE LINING	27	Packing gland bushing*	AISI 410
8	Lower O'ring	Viton	28	Packing gland flange	ASTM A216 WCB / A105
9	Stem O'ring *	Viton	29	Hex. Bolt	ASTM A193 B7M
10	Seat O'ring *	Viton	30	Handwheel	ASTM A53
11	Back up O'ring	Viton	31	Vent valve	AISI 4140
12	Upper fire safe gasket*	Graphite	32	Drain plug	AISI 4140
13	Lower fire safe gasket	Graphite	33	Stem grease fitting *	AISI 4140
14	On seat fire safe gasket	Graphite	34	Ends grease fitting	AISI 4140
15	Fire safe gasket*	Graphite	35	Lifting lug	A36
16	Lower trunnion	AISI 4140+75µm ENP / AISI 410	36	Support leg	A36
17	Flanged ends	A105N	37	Key	Carbon Steel
18	Seat spring	INCONEL X-750	38	Spring lock washer	Carbon Steel
19	Back up seat ring	ASTM A105+75µm ENP / AISI 410	39	Gear box	Commercial steel
20	Seat ring	ASTM A105+75µm ENP / AISI 411			

* Not shown

TRUNNION MOUNTED BALL VALVE BOLTED BODY, CLASS 150 (GEAR OPERATED)

Design Features

- Side entry
- Blow out proof stem
- Soft & metal - metal seats
- Gear operated from 6" and up starting from Class 150 #
- Three piece forged body design
- Bleed valve
- Fire safe packing
- Lifting lugs
- Heavy wall thickness
- Secondary seat injection sealant
- Draining plug



Catalog Figure No.	Type of Ends
8122	Raised Face (RF)
8123	Ring Type Joint (RTJ)
8124	Buttweld (WE)

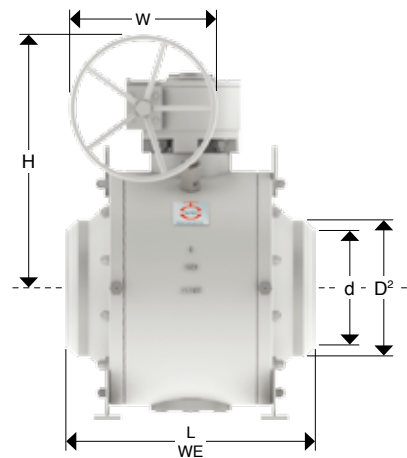
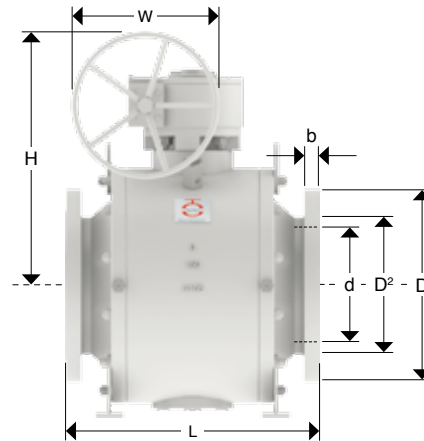

Dimensions and Weights

D Nominal Diameter	mm in	150	200	250	300	350	400	450	500	610	660	711	762	813	864	914
		6"	8"	10"	12"	14"	16"	18"	20"	24"	26"	28"	30"	32"	34"	36"
d	mm	150	201	252	303	334	385	436	487	589	633	684	735	779	830	874
	in	5.91	7.91	9.92	11.93	13.15	15.16	17.17	19.17	23.19	24.92	26.92	28.93	30.66	32.67	34.40
D	mm	280	345	405	485	535	595	635	700	815	870	925	985	1060	1110	1170
	in	10.98	13.50	15.98	19.02	20.98	23.50	25	27.52	32.01	34.25	32.01	36.41	41.73	43.70	46.06
D2	mm	216	270	324	381	413	470	533	584	692	749	800	857	914	965	1022
	in	8.50	10.63	12.76	15	16.26	18.50	20.98	23	27.24	29.48	31.49	33.74	35.98	37.99	40.23
b	mm	26	29	31	32	33.4	35	38	41	46	67	70	73	80	81	89
	in	1.02	1.14	1.22	1.26	1.34	1.37	1.4	1.61	1.81	2.63	2.75	2.87	3.14	3.18	3.50
L	mm	394	457	568	648	686	762	864	914	1067	1143	1245	1295	1372	1473	1524
	in	15.51	18	20.98	24.02	27	30	34.02	35.98	42.01	45	49	50.98	54	57.99	60
L (WE)	mm	457	521	559	635	762	838	914	991	1143	1245	1346	1397	1524	1626	1727
	in	17.99	20.51	22	25	30	32.99	35.98	39	45	49	53	55	60	64	68
H	mm	590	657	824	856	875	937	1010	1090	1180	1180	1180	1180	1180	1180	1180
	in	23.23	25.9	32.44	33.7	34.45	36.89	39.77	42.92	46.46	46.46	46.46	46.46	46.46	46.46	46.46
ØW	mm	600	600	800	800	800	800	800	800	800	APM	APM	APM	APM	APM	APM
	in	23.62	23.62	31.50	31.50	31.50	31.50	31.50	31.50	31.50	APM	APM	APM	APM	APM	APM
Weight (RF - RTJ)	kg	175	280	460	660	960	1320	1710	2150	3280	3930	4500	5370	5940	6615	7540
	Lb	386	617	1014	1455	2116	2910	3770	4740	7231	8664	9921	11839	13095	14583	16622

APM = As per manufacturer

TRUNNION MOUNTED BALL VALVE BOLTED BODY, CLASS 300

Trunnion Mounted Ball Valves are designed and manufactured in conformance with API 6D, ISO 14313, ASME B16.34, API 6FA, API 607 & NACE MR01-75.

Design Features

- Sizes NPS (DN): 2”(50mm) to 48”(1200mm)
- ASME Class: 300 #
- Temperature ratings: -50°C to 121°C (standard design)
- Design: API 6D/ISO14313, ASME B16.34
- Face to face, end to end: API 6D, ASME B16.10
- Butt weld ends: ASME B16.25
- Test: API 6D, API 598, ISO 5208
- Fire test: API 6FA, BS6755, API607
- Sour environments: NACE MR-01-75
- Seals area overlay: Upon request

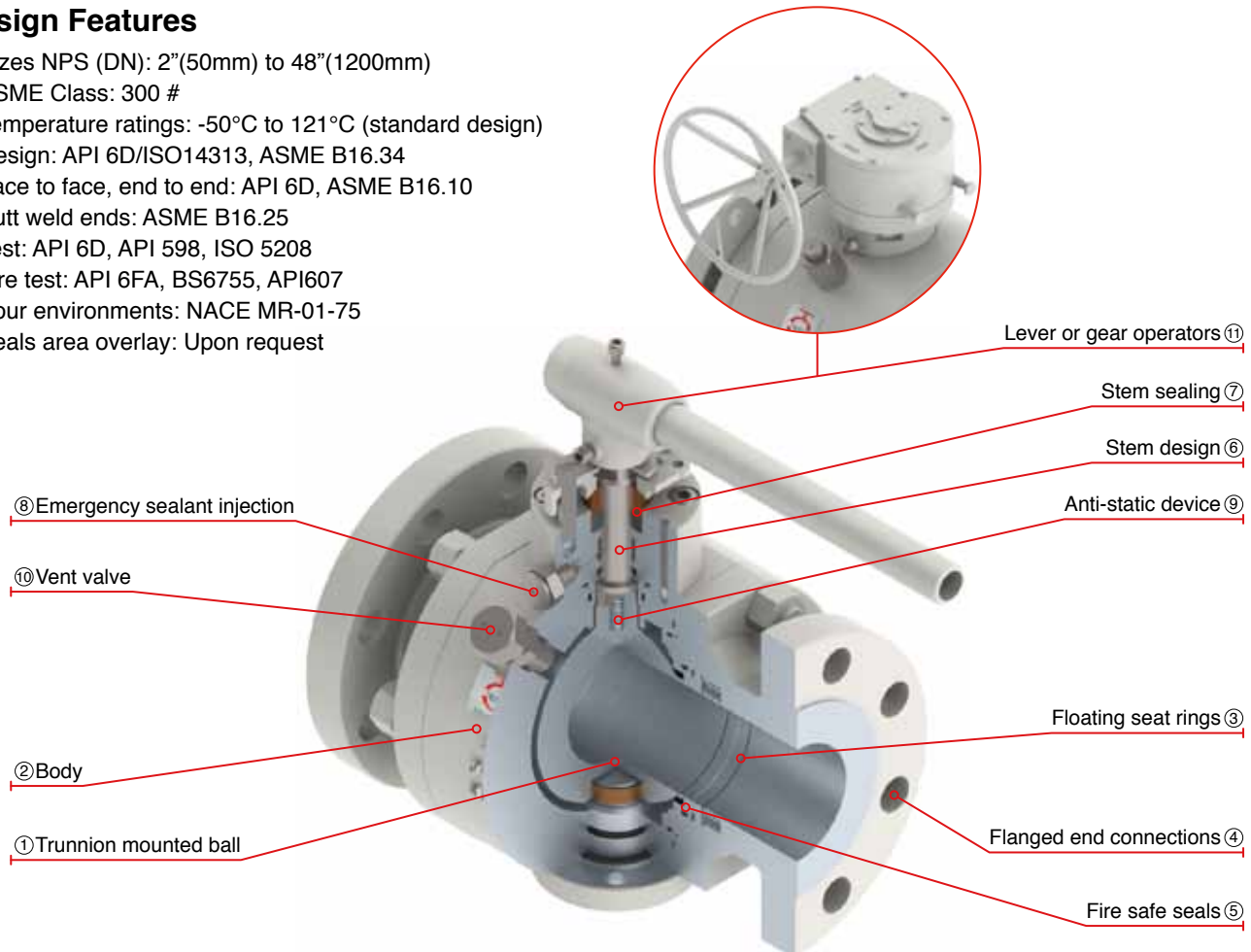

- ① Trunnion mounted ball: For all sizes & pressure ratings. The ball is fixed by an upper & lower trunnion, seat rings are dynamic which will move freely along the horizontal axis.
- ② Body. Three piece forged steel body for easy disassembly on site. Small cavities between body, seats & ball minimize the quantity of fluid that could get stored in that hollow space.
- ③ Floating seat rings. Two independent dynamic seat rings attain Bi-Directional closure of the valve these Seat. Rings are spring loaded that achieve tight shut-off at considerable low differential pressure.
- ④ Flanged ends connections. Forged steel RF or RTJ connections according to ASME B16.5 up to 24” and ASME B16.47 Series A for 26” & larger.
- ⑤ Fire safe seals: Fire safe design prevents leakage when the elastomeric seals are exposed to very high temperatures.
- ⑥ Stem design: Bottom entry anti blow out stem is made of one piece which is held up by the valve body. It has been design to avoid any possible projection due to hazardous conditions.
- ⑦ Stem sealing: Accurate machining process together with electro less nickel plated (ENP) coating control the hardness amongst stem, metallic components & double O’rings, these are supported by a secondary graphite seal which ensure reliable operation at high levels of sealing integrity when operating the valve.
- ⑧ Seats & stem emergency sealant injection (6” & larges): Valves are supplied with emergency sealant Injectors located between the double O’ring arrangement of the seat assembly & stem seal area. A highly viscous sealant is injected through these fittings to restore closure integrity.*Whenever the valve lifetime has ended or if any of the seats get damaged, the emergency sealant injection system may temporarily be used to achieve tightness before maintenance takes place.
- ⑨ Antistatic device: An inconel spring is placed between body, ball and stem to prevent static continuity.
- ⑩ Block & bleed: Double block & bleed is achieved with the valve in two positions either fully closed or fully opened.
- ⑪ Lever handle: 6” & larger valves supplied with gear operator.

TRUNNION MOUNTED BALL VALVE BOLTED BODY, CLASS 300 (LEVER OPERATED)

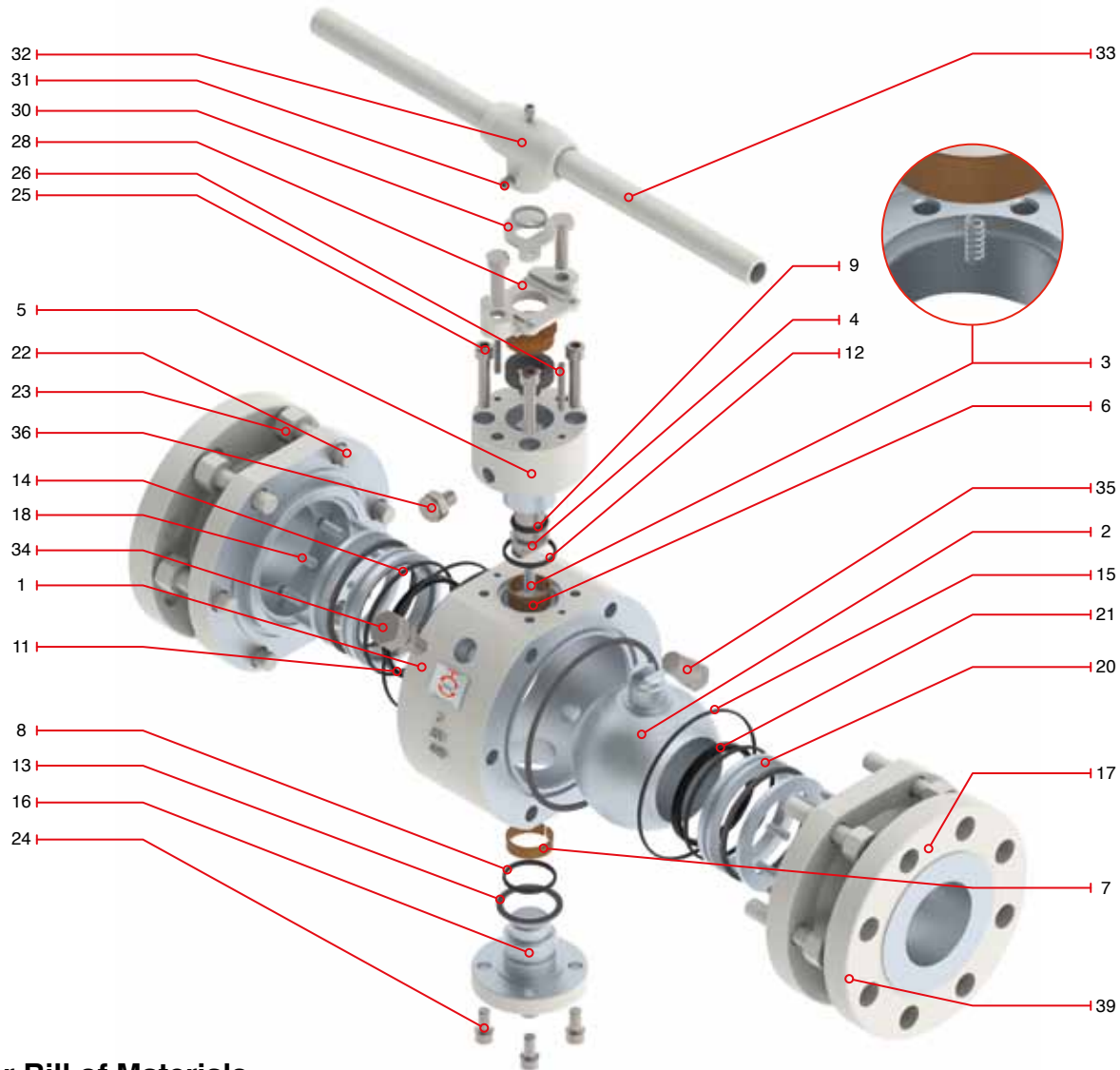

Regular Bill of Materials

No.	Description	ASTM Materials	No.	Description	ASTM Materials
1	Body	ASTM A105N	21	Seat insert	RPTFE
2	Ball	ASTM A105+75µm ENP / AISI 410	22	Stud	ASTM A193 B7M
3	Antistatic spring	INCONEL X-750	23	Nut	ASTM A194 2HM
4	Stem	AISI 4140+75µm ENP / AISI 410	24	Bottom socket screw	ASTM A193 B7M
5	Trunnion / bonnet	AISI 4140+75µm ENP	25	Top socket screw	ASTM A193 B7M
6	Upper bearing	C.S.+ PTFE LINING	26	Pin	Carbon Steel
7	Lower bearing	C.S.+ PTFE LINING	27	Locking device*	A36
8	Lower O'ring	Viton	28	Packing gland flange	ASTM A216 WCB / A105
9	Stem O'ring	Viton	29	Hex. Bolt*	ASTM A193 B7M
10	On seat O'ring*	Viton	30	Stop plate	A36
11	Back up O'ring	Viton	31	Retainer	AISI 1070
12	Upper fire safe gasket	Graphite	32	Handle nut	ASTM A216 WCB
13	Lower fire safe gasket	Graphite	33	Handle	ASTM A53
14	On seat fire safe gasket	Graphite	34	Vent valve	Carbon Steel
15	Ends flange fire safe gasket	Graphite	35	Drain plug	Carbon Steel
16	Lower trunnion	AISI 4140+75µm ENP / AISI 410	36	Stem grease fitting	AISI 4140
17	Flanged ends	A105N	37	Flanged end grease fitting*	AISI 4140
18	Seat spring	INCONEL X-750	38	Lifting lug*	A36
19	Back up seat ring*	ASTM A105+75µm ENP / AISI 410	39	Support leg*	A36
20	Seat ring	ASTM A105+75µm ENP / AISI 410			

*Not shown

TRUNNION MOUNTED BALL VALVE BOLTED BODY, CLASS 300 (LEVER OPERATED)

Design Features

- Side entry
- Blow out proof stem
- Soft & metal - metal seats
- Gear operated from 6" and up starting from Class 150 #
- Three piece forged body design
- Bleed valve
- Fire safe packing
- Lifting lugs
- Heavy wall thickness
- Secondary seat injection sealant
- Draining plug



Catalog Figure No.	Type of Ends
8312	Raised Face (RF)
8313	Ring Type Joint (RTJ)
8314	Buttweld (WE)

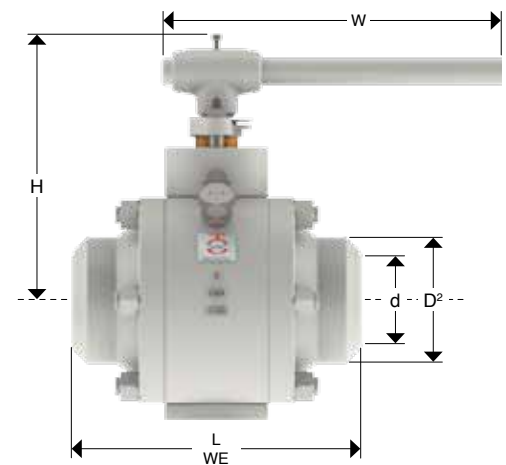
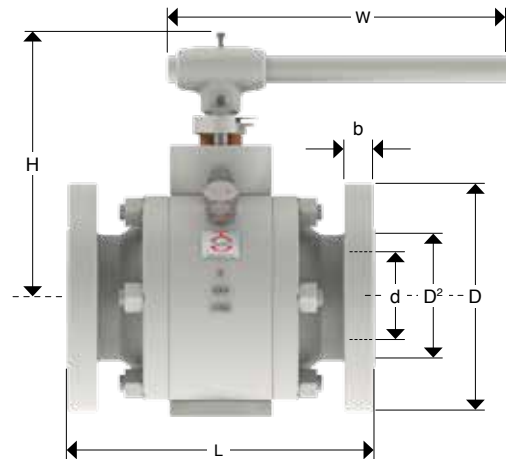

Dimensions and Weights

Nominal Diameter	mm	50	65	80	100
	in	2"	2 1/2"	3"	4"
d	mm	49	62	74	100
	in	1.93	2.44	2.91	3.94
D	mm	165	190	210	254
	in	6.50	7.48	8.27	9.02
D2	mm	92	105	127	157
	in	3.62	4.13	5	6.18
b	mm	23	26	29	32
	in	0.63	1.02	1.14	0.94
L	mm	216	241	283	305
	in	8.50	9.49	11.14	9.02
L (WE)	mm	216	241	283	305
	in	8.5	9.48	11.14	12
H	mm	172	210	241	275
	in	6.79	8.28	9.50	10.84
ØW	mm	350	450	500	600
	in	13.78	17.72	19.69	23.62
Weight (RF - RTJ)	kg	23	34	45	76
	Lb	50.6	74.8	99	167.2

Key Parameters

Code	Name
d	Bore diameter
D	Flange diameter
D2	Raised face diameter
b	Flange thickness
L	Raised face and ring type joint face to face
L (WE)	Welded end face to face
H	Height
ØW	Handwheel diameter
Weight	Weight

TRUNNION MOUNTED BALL VALVE BOLTED BODY, CLASS 300 (GEAR OPERATED)

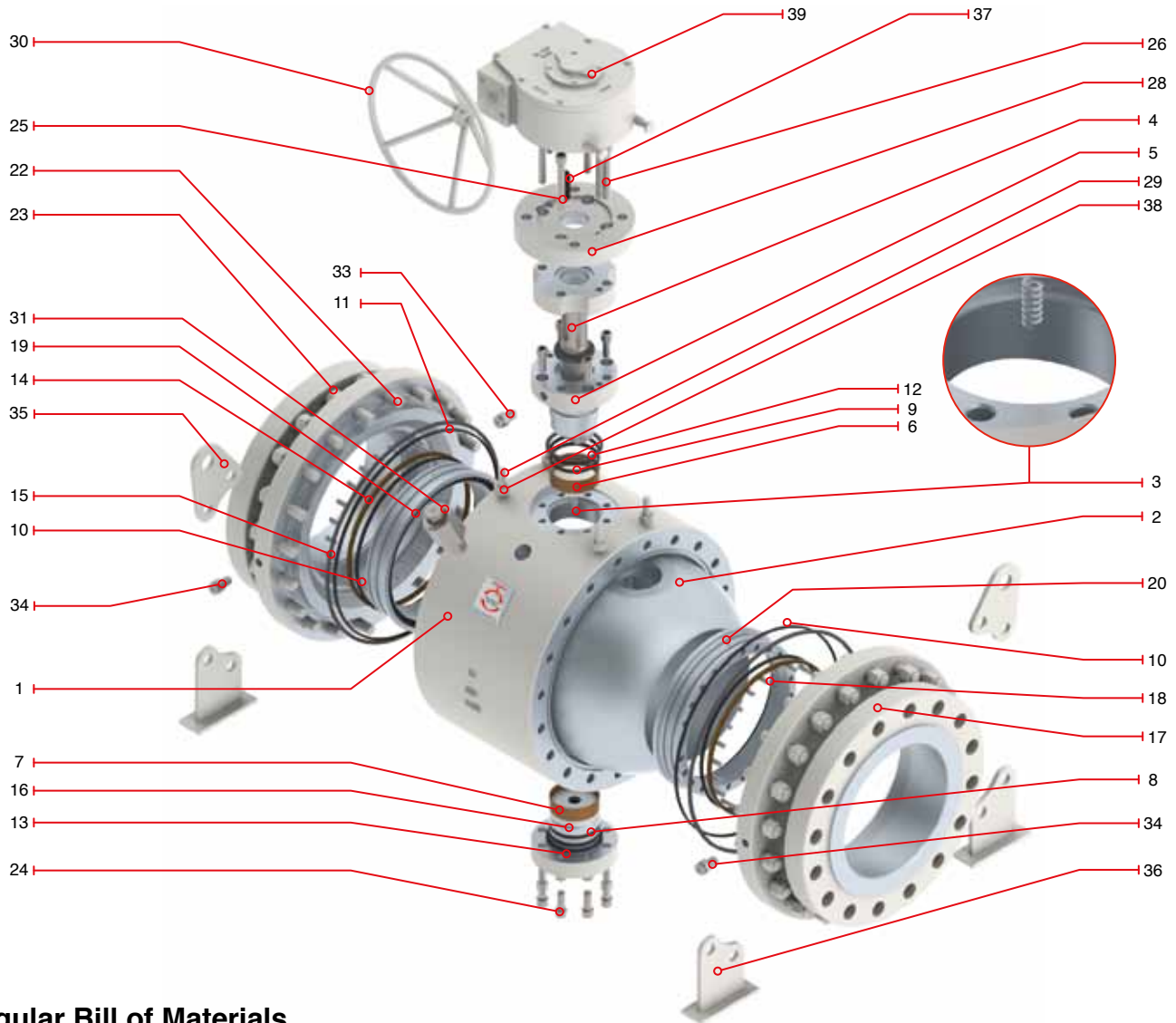

Regular Bill of Materials

No.	Description	ASTM Materials	No.	Description	ASTM Materials
1	Body	ASTM A105N	21	Seat insert*	RPTFE
2	Ball	ASTM A105+75µm ENP / AISI 410	22	Stud	ASTM A193 B7M
3	Antistatic spring	INCONEL X-750	23	Nut	ASTM A194 2HM
4	Stem	AISI 4140+75µm ENP / AISI 410	24	Bottom socket screw	ASTM A193 B7M
5	Trunnion / bonnet	AISI 4140+75µm ENP	25	Top socket screw	ASTM A193 B7M
6	Upper bearing	C.S.+ PTFE LINING	26	Pin	ASTM A276 T410
7	Lower Bearing	C.S.+ PTFE LINING	27	Packing gland bushing*	AISI 410
8	Lower O'ring	Viton	28	Packing gland flange	ASTM A216 WCB / A105
9	Stem O'ring	Viton	29	Hex. Bolt	ASTM A193 B7M
10	Seat O'ring	Viton	30	Handwheel	ASTM A53
11	Back up O'ring	Viton	31	Vent valve	AISI 4140
12	Upper fire safe gasket	Graphite	32	Drain plug*	AISI 4140
13	Lower fire safe gasket	Graphite	33	Stem grease fitting	AISI 4140
14	On seat fire safe gasket	Graphite	34	Ends grease fitting	AISI 4140
15	Fire safe gasket	Graphite	35	Lifting lug	A36
16	Lower trunnion	AISI 4140+75µm ENP / AISI 410	36	Support leg	A36
17	Flanged ends	A105N	37	Key	Carbon Steel
18	Seat spring	INCONEL X-750	38	Spring lock washer	Carbon Steel
19	Back up seat ring	ASTM A105+75µm ENP / AISI 410	39	Gear box	Commercial steel
20	Seat ring	ASTM A105+75µm ENP / AISI 411			

*Not shown

TRUNNION MOUNTED BALL VALVE BOLTED BODY, CLASS 300 (GEAR OPERATED)

Design Features

- Side entry
- Blow out proof stem
- Soft & metal - metal seats
- Gear operated from 6" and up starting from Class 300 #
- Three piece forged body design
- Bleed valve
- Fire safe packing
- Lifting lugs
- Heavy wall thickness
- Secondary seat injection sealant
- Draining plug



Catalog Figure No.	Type of Ends
8322	Raised Face (RF)
8323	Ring Type Joint (RTJ)
8324	Buttweld (WE)

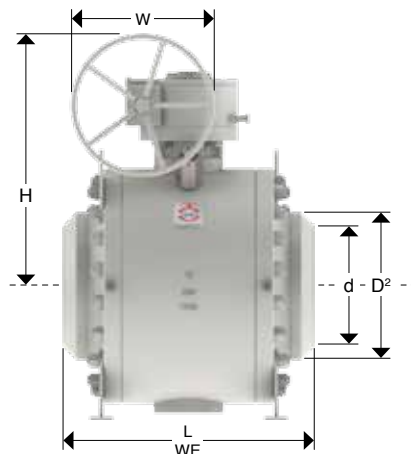
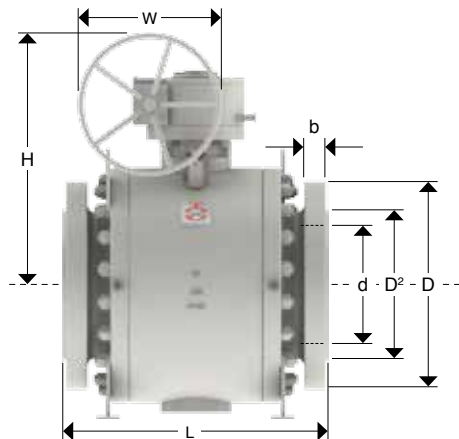

Dimensions and Weights

Nominal Diameter	mm	150	200	250	300	350	400	450	500	610	660	711	762	813	864	914
	in	6"	8"	10"	12"	14"	16"	18"	20"	24"	26"	28"	30"	32"	34"	36"
d	mm	150	201	252	303	334	385	436	487	589	633	684	735	779	830	874
	in	5.91	7.91	9.92	11.93	13.15	15.16	17.17	19.17	23.19	24.92	26.92	28.93	30.66	32.67	34.40
D	mm	318	381	445	521	585	650	710	775	915	970	1035	1090	1150	1205	1270
	in	12.52	15	17.52	20.51	23	25.59	27.95	30.51	36.02	38.18	40.74	42.91	45.27	47.44	50
D2	mm	216	270	324	381	413	470	533	584	692	749	800	857	914	965	1022
	in	8.50	10.63	12.76	15	16.25	18.50	20.98	23	27.24	29.48	31.49	33.74	35.98	37.99	40.23
b	mm	37	42	48	51	52.4	55.6	58.8	62	68.3	77.8	84.2	90.5	96.9	100.1	103.2
	in	1.46	1.65	1.89	2.01	2.13	2.18	2.31	2.44	2.68	3.06	3.31	3.56	3.81	3.94	4.06
L	mm	403	502	568	648	762	838	914	991	1143	1245	1346	1397	1524	1626	1727
	in	15.86	19.76	22.36	25.51	30	33	35.98	39	45	49	53	55	60	64	68
L (WE)	mm	403	521	559	635	762	838	914	991	1143	1245	1346	1397	1524	1626	1727
	in	15.86	20.51	22	25	30	33	35.98	39	45	49	53	55	60	64	68
H	mm	590	657	824	856	770	937	1010	1090	1180	937	937	937	937	937	937
	in	23.23	25.9	32.44	33.7	30.31	36.89	39.77	42.92	46.46	36.89	36.89	36.89	36.89	36.89	36.89
ØW	mm	600	600	800	800	800	800	800	800	800	800	800	800	800	800	800
	in	23.62	23.62	31.50	31.50	31.50	31.50	31.50	31.50	31.50	31.50	31.50	31.50	31.50	31.50	31.50
Weight	kg	185	320	510	730	1130	1490	1910	2340	3420	4340	4960	5950	6760	8280	9640
(RF - RTJ)	Lb	407	704	1122	1606	2486	3278	4202	5148	7524	9548	10912	13112	14872	18216	21208

TRUNNION MOUNTED BALL VALVE BOLTED BODY, CLASS 600

Trunnion mounted ball valves are designed and manufactured in conformance with the specification of API 6D, ISO 14313, ASME B16.34, API 6FA, API 607 & NACE MR01-75.

Design Features

- Sizes NPS (DN): 2”(50mm) to 48”(1200mm)
- ASME class: 600 #
- Temperature Ratings: -29°C to 121°C (Standard)
- Design: API 6D/ISO14313, ASME B16.34
- Face to face, end to end: API 6D, ASME B16.10
- Butt weld ends: ASME B16.25
- Test: API 6D, API 598, ISO 5208
- Fire test: API 6FA, BS6755, API607
- Sour environments: NACE MR-01-75
- Seals area overlay: On request

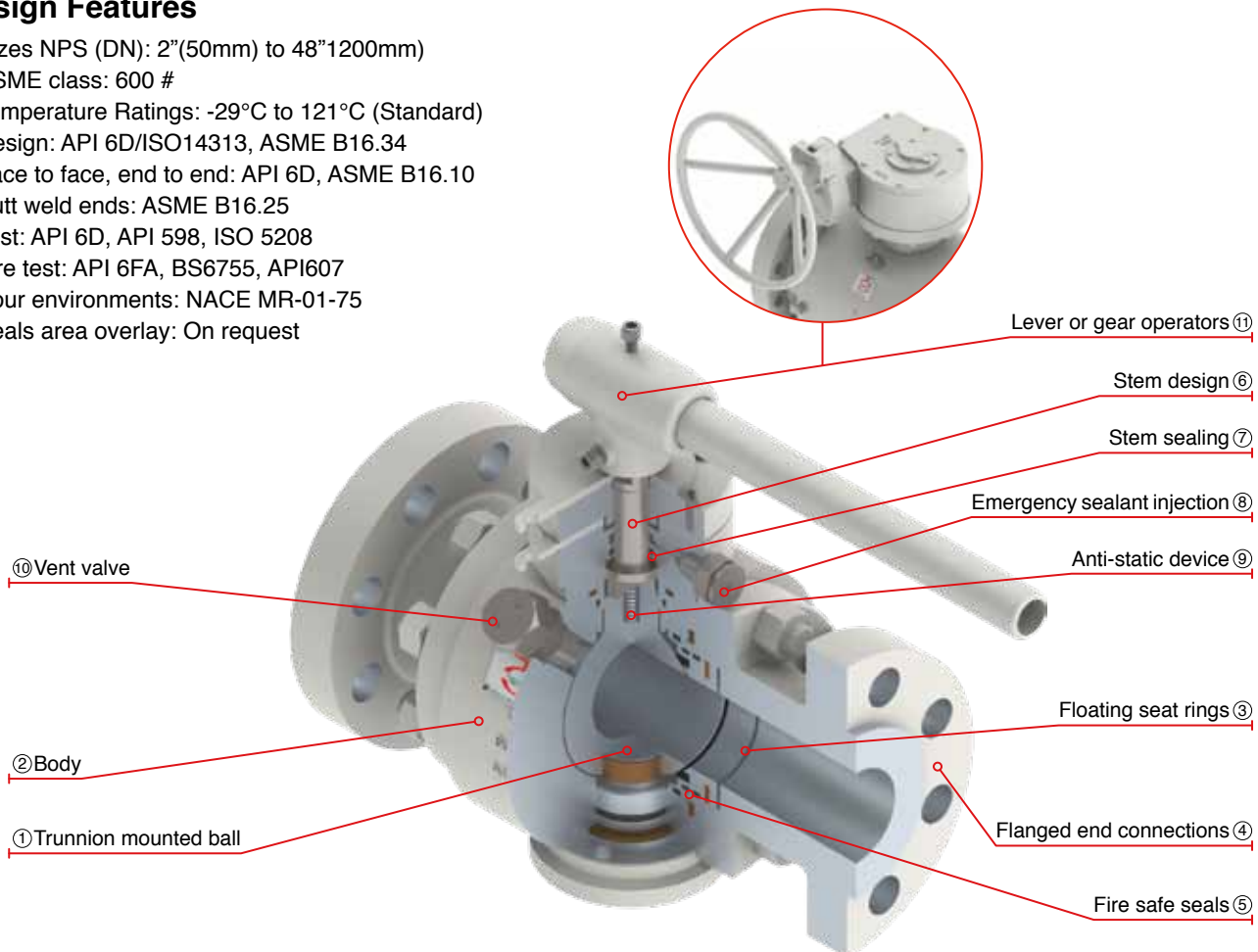

- ① Trunnion mounted ball: For all sizes & pressure ratings. The ball is fixed by an upper & lower trunnion, seat rings are dynamic which will move freely along the horizontal axis.
- ② Body. Three piece forged steel body for easy disassembly on site. Small cavities between body, seats & ball minimize the quantity of fluid that could get stored in that hollow space.
- ③ Floating seat rings. Two independent dynamic seat rings attain Bi-Directional closure of the valve these Seat. Rings are spring loaded that achieve tight shut-off at considerable low differential pressure.
- ④ Flanged ends connections. Forged steel RF or RTJ connections according to ASME B16.5 up to 24” and ASME B16.47 Series A for 26” & larger.
- ⑤ Fire safe seals: Fire safe design prevents leakage when the elastomeric seals are exposed to very high temperatures.
- ⑥ Stem design: Bottom entry anti blow out stem is made of one piece which is held up by the valve body. It has been design to avoid any possible projection due to hazardous conditions.
- ⑦ Stem sealing: Accurate machining process together with electro less nickel plated (ENP) double explosive decompression resistant (EDR) O’rings, these are supported by a secondary graphite seal which ensure reliable operation at high levels of sealing integrity when operating the valve.
- ⑧ Seats & stem emergency sealant injection (4” & larger): Valves are supplied with emergency sealant Injectors located between the double O’ring arrangement of the seat assembly & stem seal area. A highly viscous sealant is injected through these fittings to restore closure integrity.*Whenever the valve lifetime has ended or if any of the seats get damaged, the emergency sealant injection system may temporarily be used to achieve tightness before maintenance takes place.
- ⑨ Antistatic device: An inconel spring is placed between body, ball and stem to prevent static continuity.
- ⑩ Block & bleed: Double block & bleed is achieved with the valve in two positions either fully closed or fully opened.
- ⑪ Lever handle: 6” & larger valves supplied with gear operator.

TRUNNION MOUNTED BALL VALVE BOLTED BODY, CLASS 600 (LEVER OPERATED)

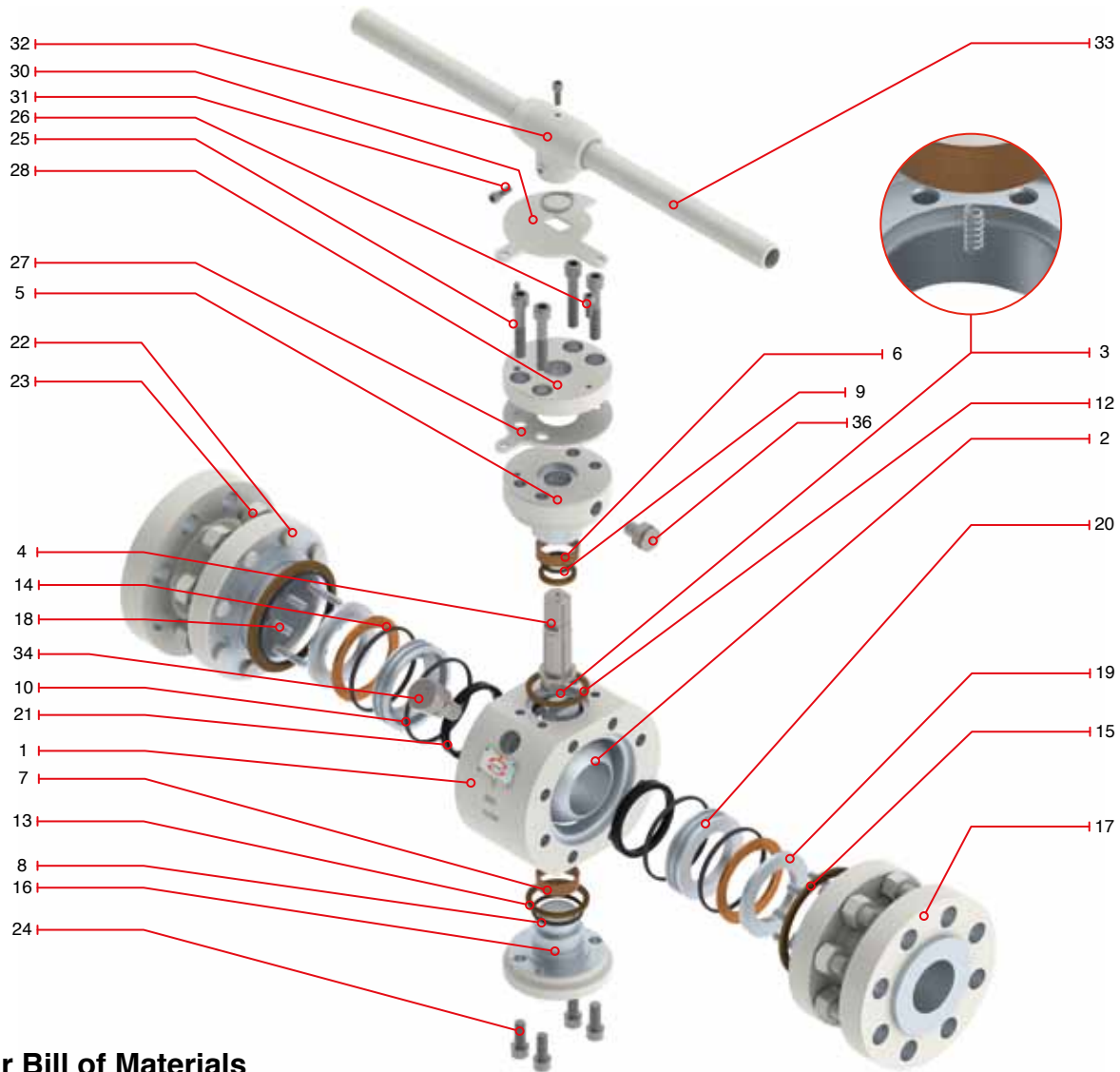

Regular Bill of Materials

No.	Description	ASTM Materials	No.	Description	ASTM Materials
1	Body	ASTM A105N	21	Seat insert	RPTFE
2	Ball	ASTM A105+75µm ENP / AISI 410	22	Stud	ASTM A193 B7M
3	Antistatic spring	INCONEL X-750	23	Nut	ASTM A194 2HM
4	Stem	AISI 4140+75µm ENP / AISI 410	24	Bottom socket screw	ASTM A193 B7M
5	Trunnion / bonnet	AISI 4140+75µm ENP	25	Top socket screw	ASTM A193 B7M
6	Upper bearing	C.S.+ PTFE LINING	26	Pin	Carbon Steel
7	Lower bearing	C.S.+ PTFE LINING	27	Locking device	A36
8	Lower O'ring	Viton	28	Packing gland flange	ASTM A216 WCB / A105
9	Stem O'ring	Viton	29	Hex. Bolt*	ASTM A193 B7M
10	On seat O'ring*	Viton	30	Stop plate	A36
11	Back up O'ring*	Viton	31	Retainer	AISI 1070
12	Upper fire safe gasket	Graphite	32	Handle nut	ASTM A216 WCB
13	Lower fire safe gasket	Graphite	33	Handle	ASTM A53
14	On seat fire safe gasket	Graphite	34	Vent valve	Carbon Steel
15	Ends flange fire safe gasket	Graphite	35	Drain plug*	Carbon Steel
16	Lower trunnion	AISI 4140+75µm ENP / AISI 410	36	Stem grease fitting*	AISI 4140
17	Flanged ends	A105N	37	Grease fitting*	AISI 4140
18	Seat spring	INCONEL X-750	38	Lifting lug*	A36
19	Back up seat ring*	ASTM A105+75µm ENP / AISI 410	39	Support leg*	A36
20	Seat ring	ASTM A105+75µm ENP / AISI 410			

* Not shown

TRUNNION MOUNTED BALL VALVE BOLTED BODY, CLASS 600 (LEVER OPERATED)

Design Features

- Side entry
- Blow out proof stem
- Soft & metal - metal seats
- Gear operated from 6" and up starting from Class 600 #
- Three piece forged body design
- Bleed valve
- Fire safe packing
- Lifting lugs
- Heavy wall thickness
- Secondary seat injection sealant
- Draining plug



Catalog Figure No.	Type of Ends
8612	Raised Face (RF)
8613	Ring Type Joint (RTJ)
8614	Buttweld (WE)

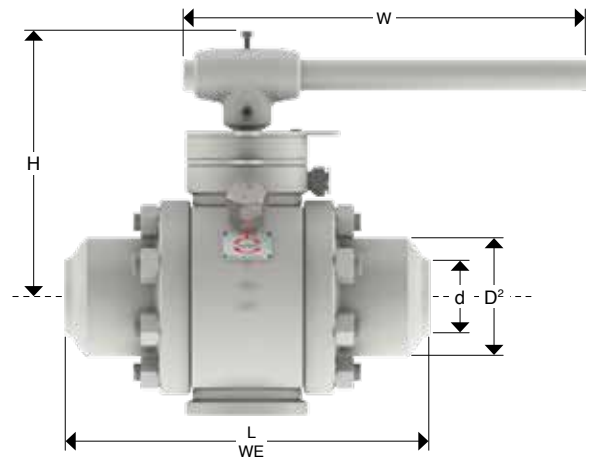
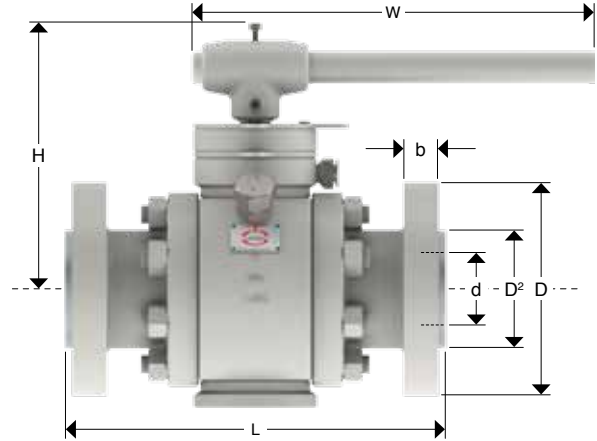

Dimensions and Weights

Nominal Diameter	mm	50	65	80	100
	in	2"	2 ½"	3"	4"
d	mm	49	62	74	100
	in	1.93	2.44	2.91	3.94
D	mm	165	190	210	275
	in	6.50	7.48	8.27	10.75
D2	mm	92	105	127	157
	in	3.62	4.13	5	6.18
b	mm	26	29	32	38
	in	1.02	1.14	1.26	1.50
L	mm	292	330	356	432
	in	11.50	13	14.02	17.01
L (WE)	mm	292	330	356	432
	in	11.50	13	14.02	17.01
H	mm	203	220	220	255
	in	8.01	8.68	8.68	10.06
ØW	mm	500	600	700	800
	in	19.69	23.62	27.56	31.50
Weight (RF - RTJ)	kg	34	51	67	150
	Lb	74,8	112,4	147,7	330,69

Key Parameters

Code	Name
d	Bore diameter
D	Flange diameter
D2	Raised face diameter
b	Flange thickness
L	Raised face and ring type joint face to face
L (WE)	Welded end face to face
H	Height
ØW	Handwheel diameter
Weight	Weight

TRUNNION MOUNTED BALL VALVE BOLTED BODY, CLASS 600 (GEAR OPERATED)

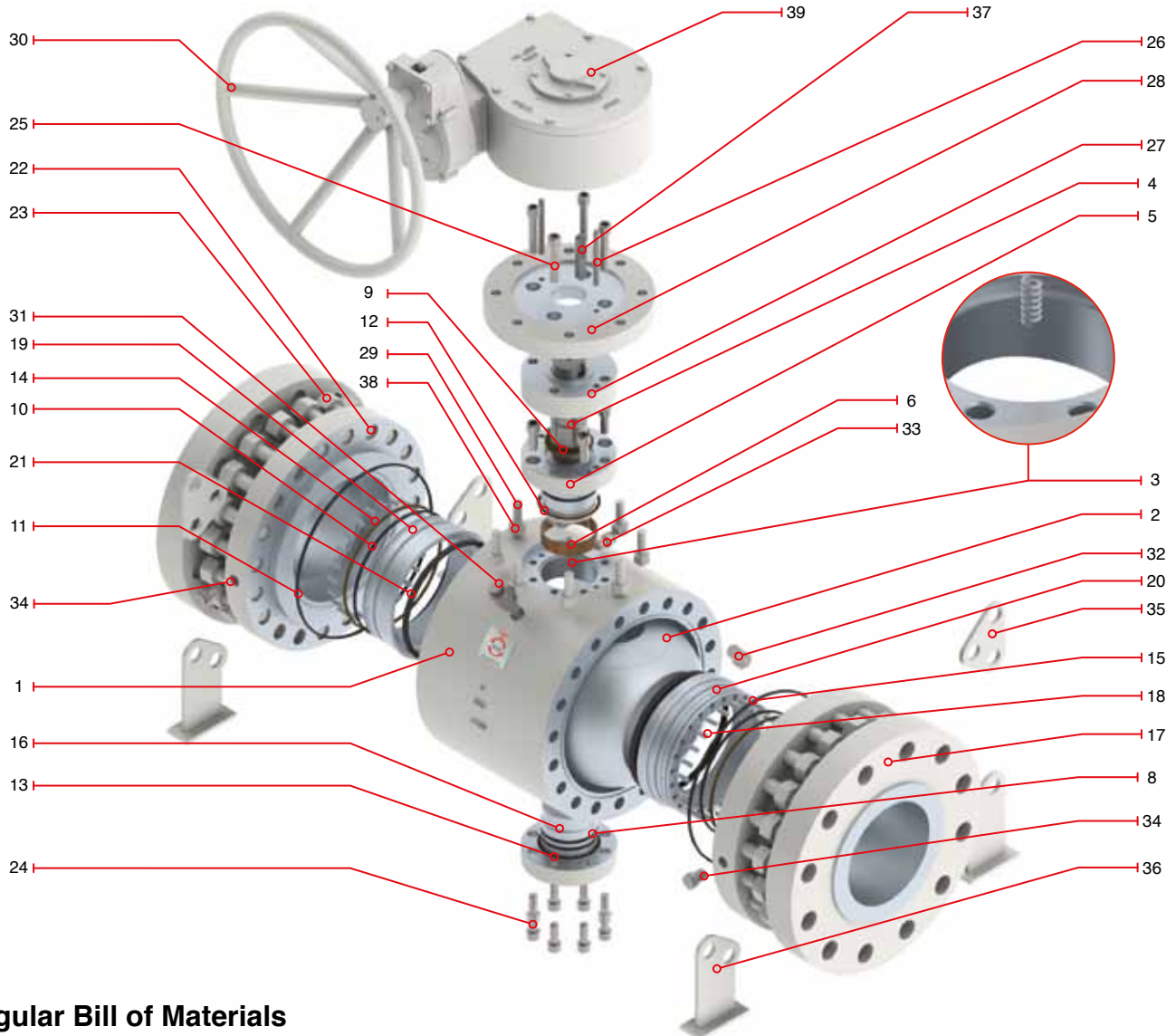

Regular Bill of Materials

No.	Description	ASTM Materials	No.	Description	ASTM Materials
1	Body	ASTM A105N	21	Seat insert	RPTFE
2	Ball	ASTM A105+75µm ENP / AISI 410	22	Stud	ASTM A193 B7M
3	Antistatic spring	INCONEL X-750	23	Nut	ASTM A194 2HM
4	Stem	AISI 4140+75µm ENP / AISI 410	24	Bottom socket screw	ASTM A193 B7M
5	Trunnion / bonnet	AISI 4140+75µm ENP	25	Top socket screw	ASTM A193 B7M
6	Upper bearing	C.S.+ PTFE LINING	26	Pin	ASTM A276 T410
7	Lower Bearing*	C.S.+ PTFE LINING	27	Packing gland bushing	AISI 410
8	Lower O'ring	Viton	28	Packing gland flange	ASTM A216 WCB / A105
9	Stem O'ring	Viton	29	Hex. Bolt	ASTM A193 B7M
10	Seat O'ring	Viton	30	Handwheel	ASTM A53
11	Back up O'ring	Viton	31	Vent valve	AISI 4140
12	Upper fire safe gasket	Graphite	32	Drain plug	AISI 4140
13	Lower fire safe gasket	Graphite	33	Stem grease fitting	AISI 4140
14	On seat fire safe gasket	Graphite	34	Ends grease fitting	AISI 4140
15	Fire safe gasket	Graphite	35	Lifting lug	A36
16	Lower trunnion	AISI 4140+75µm ENP / AISI 410	36	Support leg	A36
17	Flanged ends	A105N	37	Key	Carbon Steel
18	Seat spring	INCONEL X-750	38	Spring lock washer	Carbon Steel
19	Back up seat ring*	ASTM A105+75µm ENP / AISI 410	39	Gear box	Commercial steel
20	Seat ring	ASTM A105+75µm ENP / AISI 411			

* Not shown

TRUNNION MOUNTED BALL VALVE BOLTED BODY, CLASS 600 (GEAR OPERATED)

Design Features

- Side entry
- Blow out proof stem
- Soft & metal - metal seats
- Gear operated from 6" and up starting from Class 600 #
- Three piece forged body design
- Bleed valve
- Fire safe packing
- Lifting lugs
- Heavy wall thickness
- Secondary seat injection sealant
- Draining plug

Catalog Figure No.	Type of Ends
8622	Raised Face (RF)
8623	Ring Type Joint (RTJ)
8624	Buttweld (WE)

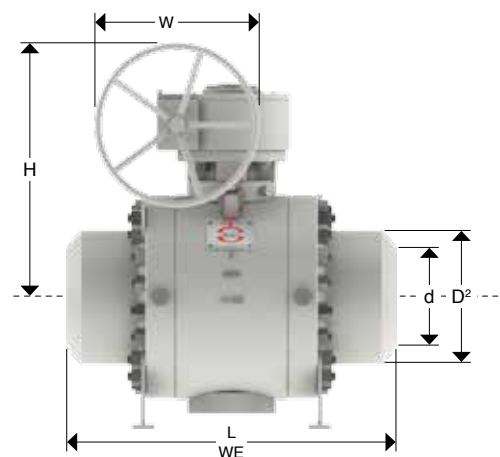
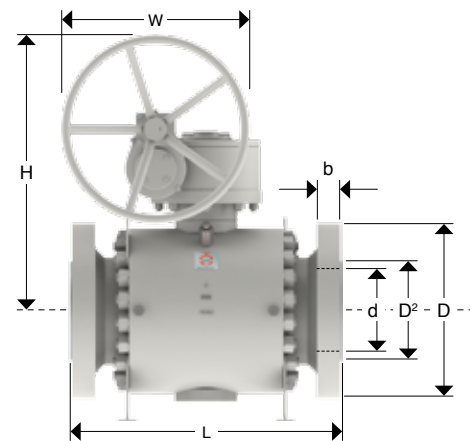

Dimensions and Weights

Nominal Diameter	mm	150	200	250	300	350	400	450	500	610	660	711	762	813	864	914
	in	6"	8"	10"	12"	14"	16"	18"	20"	24"	26"	28"	30"	32"	34"	36"
d	mm	150	201	252	303	334	385	436	487	589	633	684	735	779	830	874
	in	5.91	7.91	9.92	11.93	13.15	15.16	17.17	19.17	23.19	24.92	26.92	28.93	30.66	32.67	34.40
D	mm	355	420	510	560	605	685	745	815	940	1015	1075	1130	1195	1245	1315
	in	14.02	16.50	20	22.01	23.81	26.96	29.33	32.08	37	40	42.32	44.48	47.04	49.01	51.71
D2	mm	216	270	324	381	413	470	533	584	692	749	800	857	914	965	1022
	in	8.50	10.63	12.76	15	16.26	18.50	20.98	23	27.24	29.48	31.49	33.74	35.98	37.99	40.23
b	mm	48	56	64	67	70	76.2	83	89	102	108	111	114	117	121	124
	in	1.89	2.20	2.52	2.64	2.76	3	3.25	3.5	4.02	4.02	4.37	4.48	4.60	4.76	4.88
L	mm	559	660	787	838	889	991	1092	1194	1397	1448	1549	1651	1778	1930	2083
	in	22.01	25.98	30.98	33	35	39.02	43	47.01	55	57	60.98	65	70	75.98	82
L (WE)	mm	559	660	787	838	889	991	1092	1194	1397	1448	1549	1651	1778	1930	2083
	in	22.01	25.98	30.98	33	35	39.02	43	47.01	55	57	60.98	65	70	75.98	82
H	mm	510	580	750	790	790	833	879	919	1020	1058	1118	1153	1206	1248	1294
	in	20.07	22.83	29.53	31.1	31.1	32.79	34.6	36.18	40.15	41.65	44.01	45.39	47.48	49.13	50.94
ØW	mm	400	400	600	600	800	POA	POA	POA	POA	POA	POA	POA	POA	POA	POA
	in	15.75	15.75	23.62	23.62	31.50	POA	POA	POA	POA	POA	POA	POA	POA	POA	POA
Weight	kg	320	510	810	1060	1350	1940	2510	3250	4940	5830	6700	7450	8470	10360	12080
(RF - RTJ)	Lb	705,47	1124,35	1786	2337	2976	4277	5534	7165	10891	12853	14770	16424	18673	22839	26631

TRUNNION MOUNTED BALL VALVE BOLTED BODY, CLASS 900

Trunnion Mounted Ball Valves are designed and manufactured in conformance with API 6D, ISO 14313, ASME B16.34, API 6FA, API 607 & NACE MR01-75.

Design Features

- Sizes NPS (DN): 2”(50mm) to 48”(1200mm)
- ASME class: 900 #
- Temperature Ratings: -29°C to 121°C (Standard)
- Design: API 6D/ISO14313, ASME B16.34
- Face to face, end to end: API 6D, ASME B16.10
- Butt weld ends: ASME B16.25
- Test: API 6D, API 598, ISO 5208
- Fire test: API 6FA, BS6755, API607
- Sour environments: NACE MR-01-75
- Seals area overlay: On request

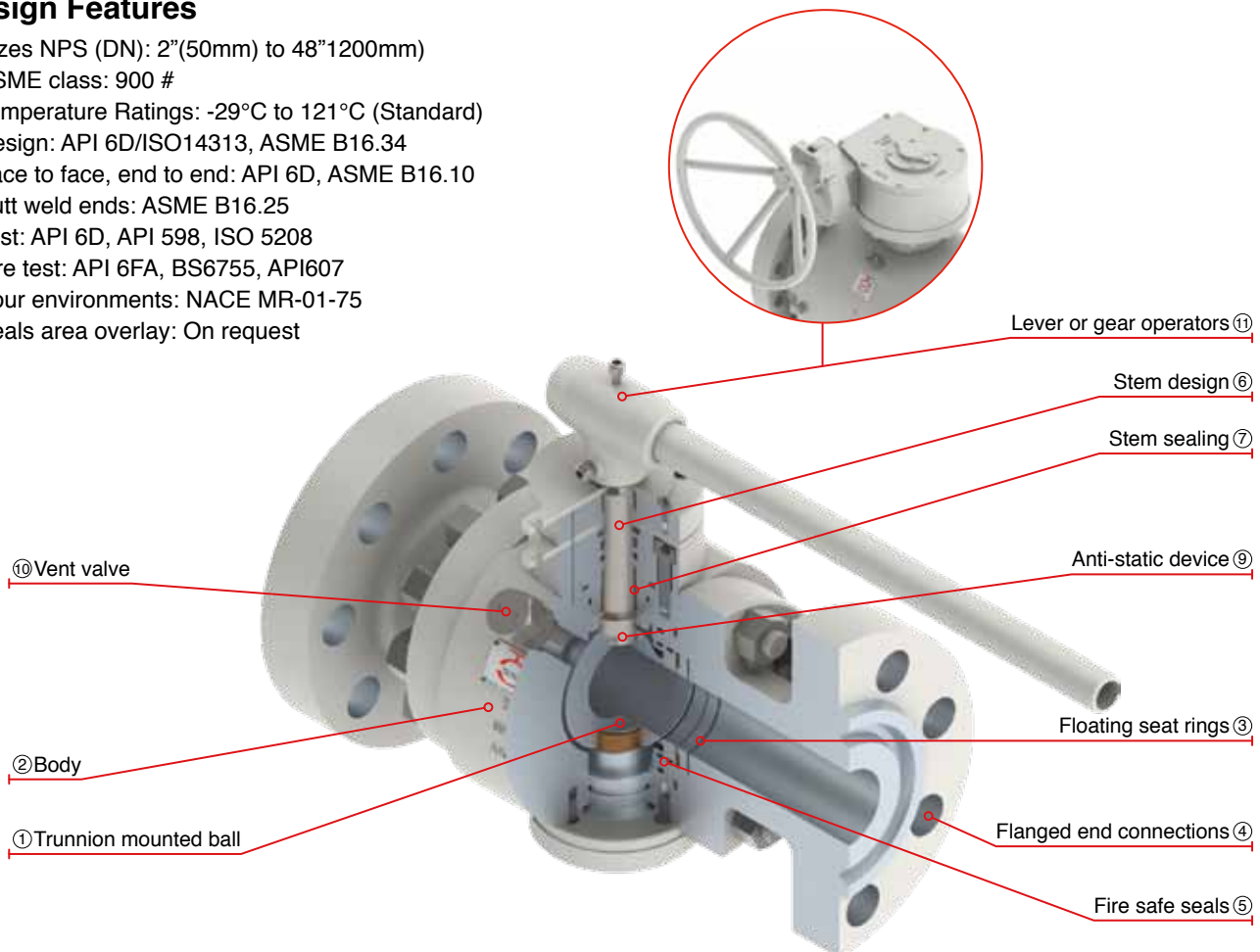

- ① Trunnion mounted ball: For all sizes & pressure ratings. The ball is fixed by an upper & lower trunnion, seat rings are dynamic which will move freely along the horizontal axis.
- ② Body. Three piece forged steel body for easy disassembly on site. Small cavities between body, seats & ball minimize the quantity of fluid that could get stored in that hollow space.
- ③ Floating seat rings. Two independent dynamic seat rings attain Bi-Directional closure of the valve these Seat. Rings are spring loaded that achieve tight shut-off at considerable low differential pressure.
- ④ Flanged ends connections. Forged steel RF or RTJ connections according to ASME B16.5 up to 24” and ASME B16.47 Series A for 26” & larger.
- ⑤ Fire safe seals: Fire safe design prevents leakage when the elastomeric seals are exposed to very high temperatures.
- ⑥ Stem design: Bottom entry anti blow out stem is made of one piece which is held up by the valve body. It has been design to avoid any possible projection due to hazardous conditions.
- ⑦ Stem sealing: Accurate machining process together with electro less nickel plated (ENP) double explosive decompression resistant (EDR) O’rings, these are supported by a secondary graphite seal which ensure reliable operation at high levels of sealing integrity when operating the valve.
- ⑧ Seats & stem emergency sealant injection (4” & larges): Valves are supplied with emergency sealant Injectors located between the double O’ring arrangement of the seat assembly & stem seal area. A highly viscous sealant is injected through these fittings to restore closure integrity.*Whenever the valve lifetime has ended or if any of the seats get damaged, the emergency sealant injection system may temporarily be used to achieve tightness before maintenance takes place.
- ⑨ Antistatic device: An inconel spring is placed between body, ball and stem to prevent static continuity.
- ⑩ Block & bleed: Double block & bleed is achieved with the valve in two positions either fully closed or fully opened.
- ⑪ Lever handle: 6” & larger valves supplied with gear operator.

TRUNNION MOUNTED BALL VALVE BOLTED BODY, CLASS 900 (LEVER OPERATED)

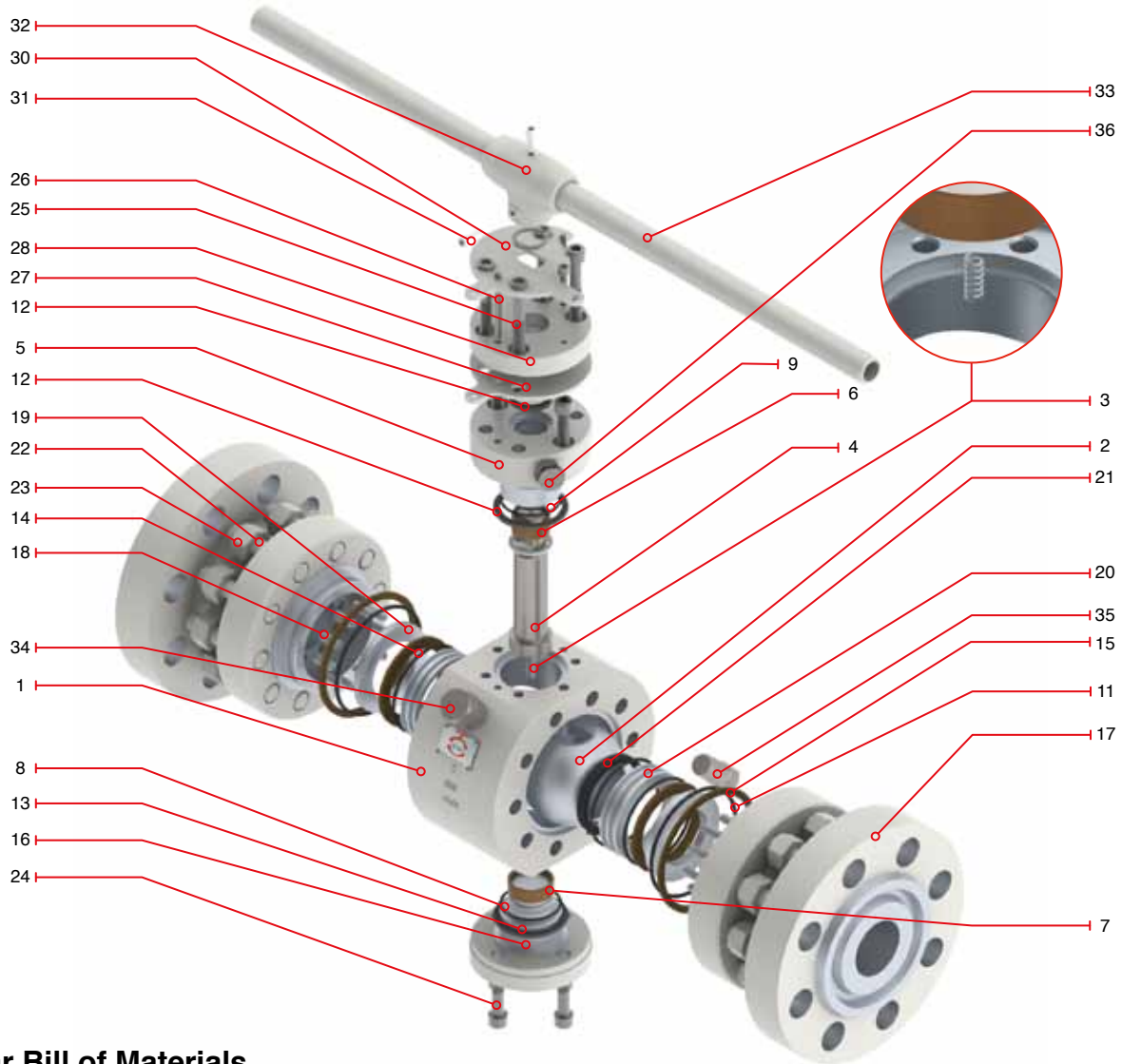

Regular Bill of Materials

No.	Description	ASTM Materials	No.	Description	ASTM Materials
1	Body	ASTM A105N	21	Seat insert	RPTFE
2	Ball	ASTM A105+75µm ENP / AISI 410	22	Stud	ASTM A193 B7M
3	Antistatic spring	INCONEL X-750	23	Nut	ASTM A194 2HM
4	Stem	AISI 4140+75µm ENP / AISI 410	24	Bottom socket screw	ASTM A193 B7M
5	Trunnion / bonnet	AISI 4140+75µm ENP	25	Top socket screw	ASTM A193 B7M
6	Upper bearing	C.S.+ PTFE LINING	26	Pin	Carbon Steel
7	Lower bearing	C.S.+ PTFE LINING	27	Locking device	A36
8	Lower O'ring	Viton	28	Packing gland flange	ASTM A216 WCB / A105
9	Stem O'ring	Viton	29	Hex. Bolt*	ASTM A193 B7M
10	On seat O'ring*	Viton	30	Stop plate	A36
11	Back up O'ring	Viton	31	Retainer	AISI 1070
12	Upper fire safe gasket	Graphite	32	Handle nut	ASTM A216 WCB
13	Lower fire safe gasket	Graphite	33	Handle	ASTM A53
14	On seat fire safe gasket	Graphite	34	Vent valve	Carbon Steel
15	Ends flange fire safe gasket	Graphite	35	Drain plug	Carbon Steel
16	Lower trunnion	AISI 4140+75µm ENP / AISI 410	36	Stem grease fitting	AISI 4140
17	Flanged ends	A105N	37	Flanged end grease fitting*	AISI 4140
18	Seat spring	INCONEL X-750	38	Lifting lug*	A36
19	Back up seat ring*	ASTM A105+75µm ENP / AISI 410	39	Support leg*	A36
20	Seat ring	ASTM A105+75µm ENP / AISI 410			

* Not shown

TRUNNION MOUNTED BALL VALVE BOLTED BODY, CLASS 900 (LEVER OPERATED)

Design Features

- Side entry
- Blow out proof stem
- Soft & metal - metal seats
- Gear operated from 6" and up starting from Class 900 #
- Three piece forged body design
- Bleed valve
- Fire safe packing
- Lifting lugs
- Heavy wall thickness
- Secondary seat injection sealant
- Draining plug



Catalog Figure No.	Type of Ends
8912	Raised Face (RF)
8913	Ring Type Joint (RTJ)
8914	Buttweld (WE)

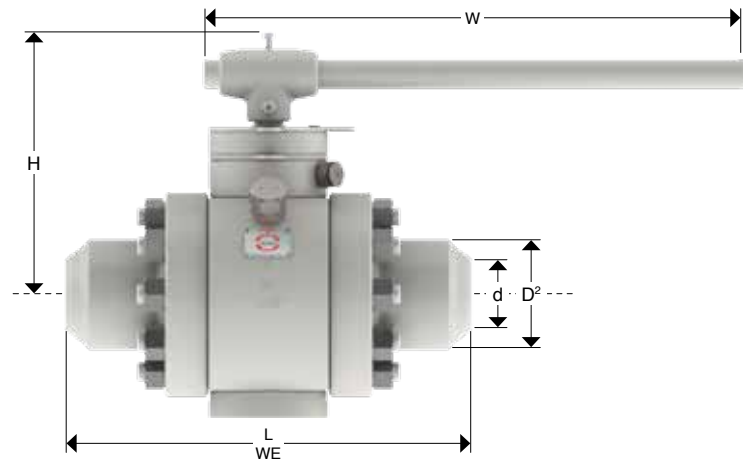
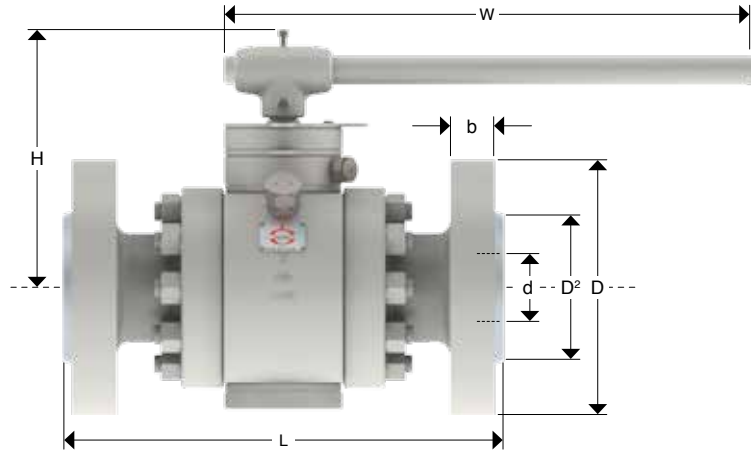

Dimensions and Weights

Nominal Diameter	mm	50	65	80	100
	in	2"	2 1/2"	3"	4"
d	mm	49	62	74	100
	in	1.93	2.44	2.91	3.94
D	mm	216	244	241	292
	in	8.50	9.61	8.27	11.50
D2	mm	92	105	127	157
	in	3.62	4.13	5	6.18
b	mm	38.5	41.5	38.5	44.5
	in	1.52	1.63	1.26	1.75
L	mm	368	419	381	457
	in	14.50	16.50	14.02	18
L (WE)	mm	368	419	381	457
	in	14.50	16.50	14.02	18
H	mm	213	220	220	275
	in	8.37	8.68	8.68	10.84
ØW	mm	700	800	800	POA
	in	27.56	23.62	27.56	
Weight (RF - RTJ)	kg	57	75	83	146
	Lb	126	165	183	322

Key Parameters

Code	Name
d	Bore diameter
D	Flange diameter
D2	Raised face diameter
b	Flange thickness
L	Raised face and ring type joint face to face
L (WE)	Welded end face to face
H	Height
ØW	Handwheel diameter
Weight	Weight

TRUNNION MOUNTED BALL VALVE BOLTED BODY, CLASS 900 (GEAR OPERATED)

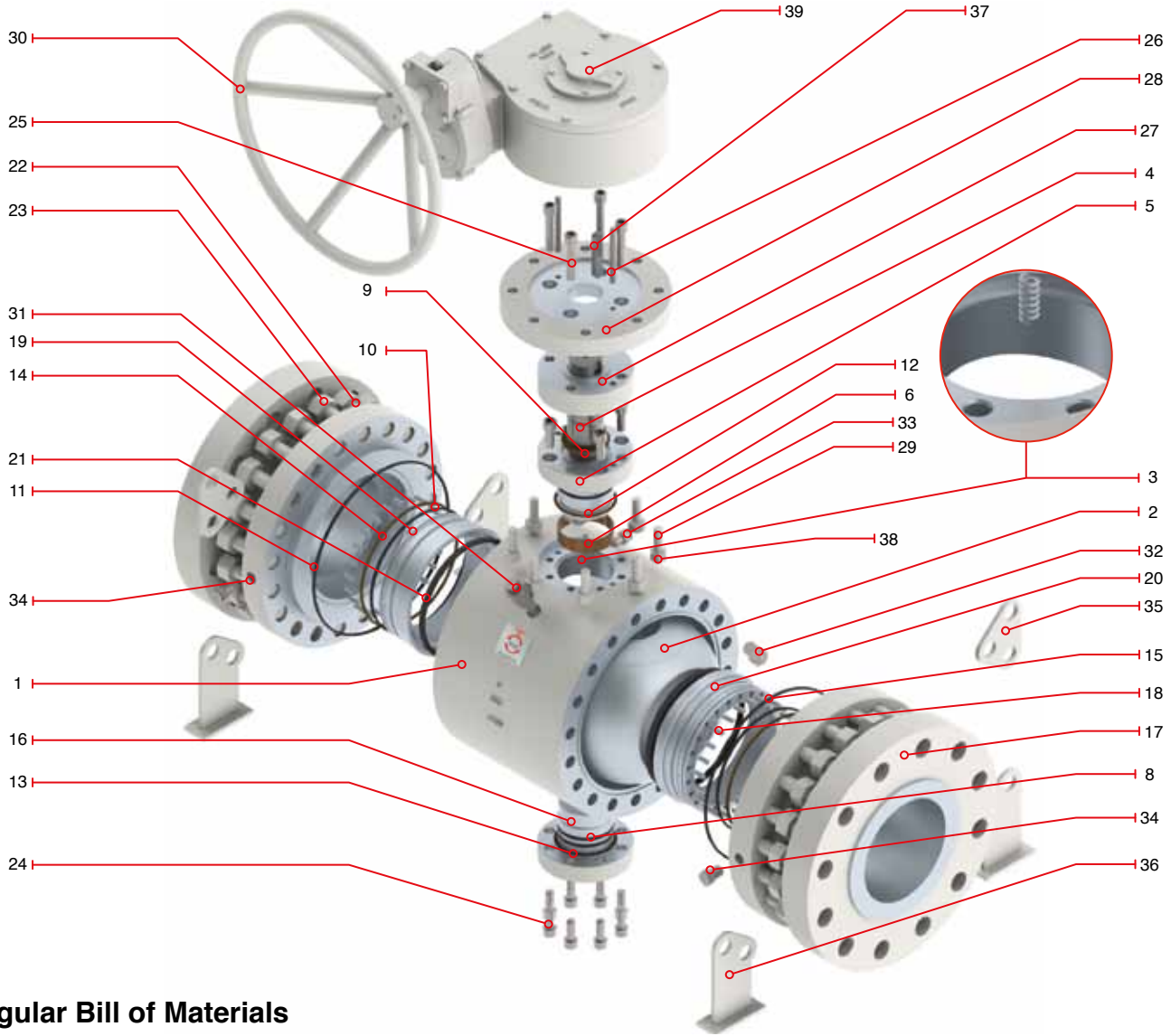

Regular Bill of Materials

No.	Description	ASTM Materials	No.	Description	ASTM Materials
1	Body	ASTM A105N	21	Seat insert	RPTFE
2	Ball	ASTM A105+75µm ENP / AISI 410	22	Stud	ASTM A193 B7M
3	Antistatic spring	INCONEL X-750	23	Nut	ASTM A194 2HM
4	Stem	AISI 4140+75µm ENP / AISI 410	24	Bottom socket screw	ASTM A193 B7M
5	Trunnion / bonnet	AISI 4140+75µm ENP	25	Top socket screw	ASTM A193 B7M
6	Upper bearing	C.S.+ PTFE LINING	26	Pin	ASTM A276 T410
7	Lower Bearing*	C.S.+ PTFE LINING	27	Packing gland bushing*	AISI 410
8	Lower O'ring	Viton	28	Packing gland flange	ASTM A216 WCB / A105
9	Stem O'ring	Viton	29	Hex. Bolt	ASTM A193 B7M
10	Seat O'ring	Viton	30	Handwheel	ASTM A53
11	Back up O'ring	Viton	31	Vent valve	AISI 4140
12	Upper fire safe gasket	Graphite	32	Drain plug	AISI 4140
13	Lower fire safe gasket	Graphite	33	Stem grease fitting*	AISI 4140
14	On seat fire safe gasket	Graphite	34	Ends grease fitting	AISI 4140
15	Fire safe gasket	Graphite	35	Lifting lug	A36
16	Lower trunnion	AISI 4140+75µm ENP / AISI 410	36	Support leg	A36
17	Flanged ends	A105N	37	Key	Carbon Steel
18	Seat spring	INCONEL X-750	38	Spring lock washer	Carbon Steel
19	Back up seat ring*	ASTM A105+75µm ENP / AISI 410	39	Gear box	Commercial steel
20	Seat ring	ASTM A105+75µm ENP / AISI 411			

* Not shown

TRUNNION MOUNTED BALL VALVE BOLTED BODY, CLASS 900 (GEAR OPERATED)

Design Features

- Side entry
- Blow out proof stem
- Soft & metal - metal seats
- Gear operated from 6" and up starting from Class 900 #
- Three piece forged body design
- Bleed valve
- Fire safe packing
- Lifting lugs
- Heavy wall thickness
- Secondary seat injection sealant
- Draining plug



Catalog Figure No.	Type of Ends
8922	Raised Face (RF)
8923	Ring Type Joint (RTJ)
8924	Buttweld (WE)

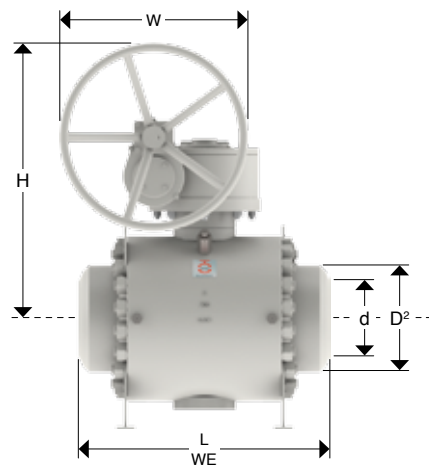
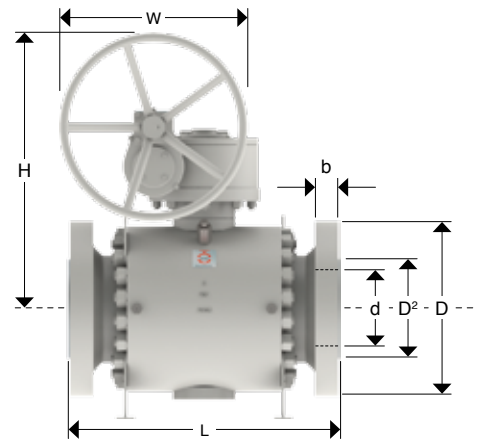

Dimensions and Weights

Nominal Diameter	mm	150	200	250	300	350	400	450	500	610	660	711	762	813	864	914
	in	6"	8"	10"	12"	14"	16"	18"	20"	24"	26"	28"	30"	32"	34"	36"
d	mm	150	201	252	303	322	373	423	471	570	617	665	712	760	808	855
	in	5.91	7.91	9.92	11.93	13.15	14.69	16.65	18.54	22.44	24.29	26.18	28.03	30	32	34
D	mm	381	470	546	610	640	705	785	855	1040	1085	1170	1230	1315	1395	1460
	in	15	18.50	21.50	24.02	25.19	27.76	31	33.66	40.94	42.71	46.06	48.42	51.77	54.92	57.48
D2	mm	216	270	324	419	467	524	594	648	772	832	889	946	1003	1067	1124
	in	8.50	10.63	12.76	15	18.38	20.67	23.38	25.51	30.39	32.75	35	37.24	39.48	42	44.25
b	mm	56	63.5	70	79.5	86	89	102	108	140	140	143	149	159	165	172
	in	2.20	2.50	2.76	3.13	3.39	3.50	3.27	4.25	5.51	5.51	5.62	5.86	6.25	6.5	6.7
L	mm	610	737	838	968	1029	1130	1219	1321	1549	1651	APM	1880	APM	APM	2286
	in	24.02	29.02	33	38	40.51	44.49	43	52.01	60.98	65	APM	74	APM	APM	90
L (WE)	mm	610	737	838	968	1029	1130	1219	1321	1549	APM	APM	APM	APM	APM	APM
	in	24.02	29.02	33	38	40.51	44.49	43	52.01	60.98	APM	APM	APM	APM	APM	APM
H	mm	690	758	824	856	875	937	1020	1080	1295	APM	APM	APM	APM	APM	APMS
	in	27.17	29.84	32.44	33.7	34.45	36.89	40.16	42.52	51	APM	APM	APM	APM	APM	APMS
ØW	mm	800	800	800	800	800	800	800	800	800	800	800	800	800	800	800
	in	31.50	31.50	31.50	31.50	31.50	31.50	31.50	31.50	31.50	31.50	31.50	31.50	31.50	31.50	31.50
Weight	kg	335	620	960	1280	1720	2250	3070	4050	6100	7070	8070	9680	11000	13470	15700
(RF - RTJ)	Lb	739	1367	2117	2822	3792	4961	6768	8929	13448	15587	17791	21341	24251	29696	34613

APM = As per manufacturer

TRUNNION MOUNTED BALL VALVE BOLTED BODY, CLASS 1500

Trunnion Mounted Ball Valves are designed and manufactured in conformance with API 6D, ISO 14313, ASME B16.34, API 6FA, API 607 & NACE MR01-75.

Design Features

- Sizes NPS (DN): 2”(50mm) to 48”(1200mm)
- ASME class: 1500 #
- Temperature Ratings: -29°C to 121°C (Standard)
- Design: API 6D/ISO14313, ASME B16.34
- Face to face, end to end: API 6D, ASME B16.10
- Butt weld ends: ASME B16.25
- Test: API 6D, API 598, ISO 5208
- Fire test: API 6FA, BS6755, API607
- Sour environments: NACE MR-01-75
- Seals area overlay: On request

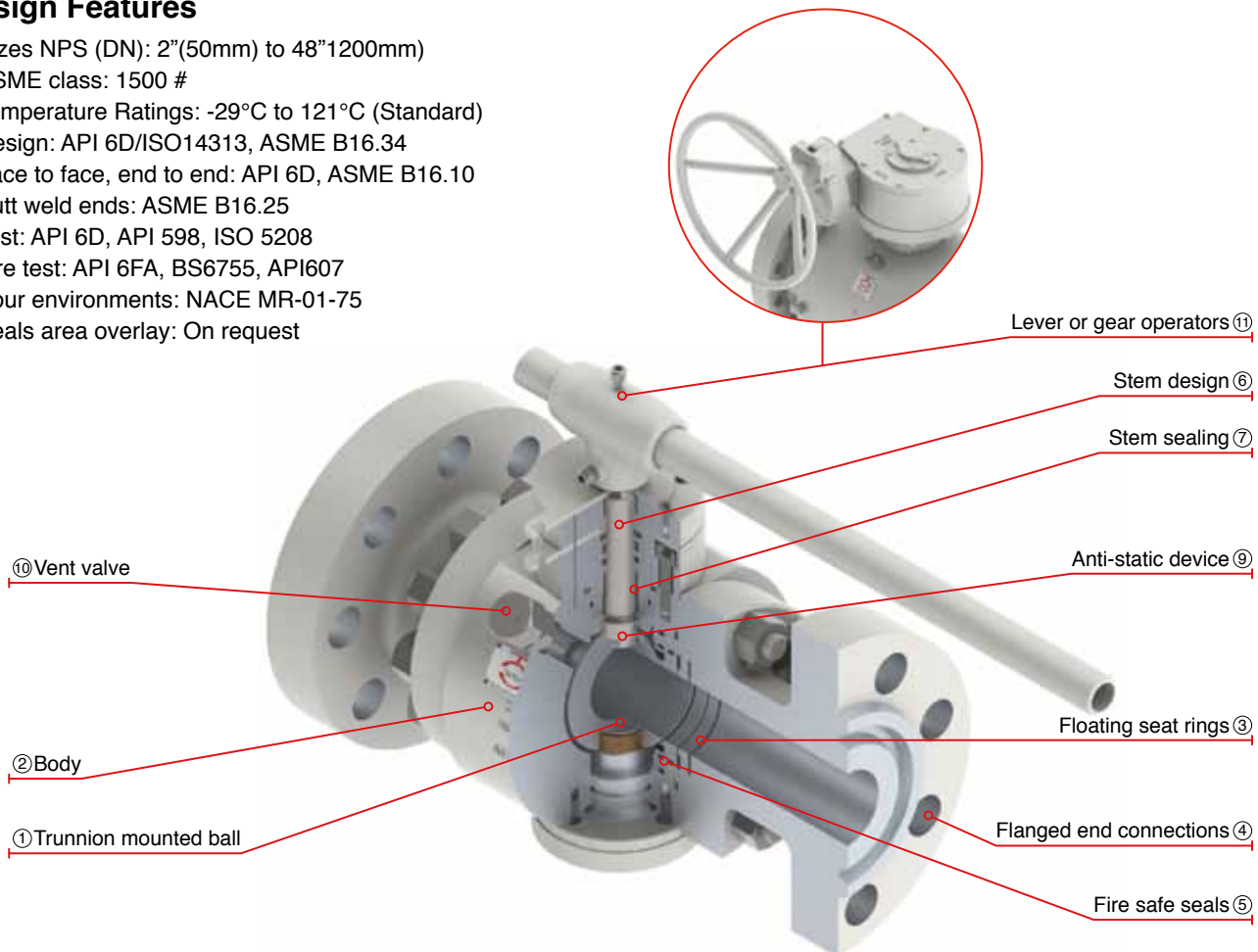

- ① Trunnion mounted ball: For all sizes & pressure ratings. The ball is fixed by an upper & lower trunnion, seat rings are dynamic which will move freely along the horizontal axis.
- ② Body. Three piece forged steel body for easy disassembly on site. Small cavities between body, seats & ball minimize the quantity of fluid that could get stored in that hollow space.
- ③ Floating seat rings. Two independent dynamic seat rings attain Bi-Directional closure of the valve these Seat. Rings are spring loaded that achieve tight shut-off at considerable low differential pressure.
- ④ Flanged ends connections. Forged steel RF or RTJ connections according to ASME B16.5 up to 24” and ASME B16.47 Series A for 26” & larger.
- ⑤ Fire safe seals: Fire safe design prevents leakage when the elastomeric seals are exposed to very high temperatures.
- ⑥ Stem design: Bottom entry anti blow out stem is made of one piece which is held up by the valve body. It has been design to avoid any possible projection due to hazardous conditions.
- ⑦ Stem sealing: Accurate machining process together with electro less nickel plated (ENP) double explosive decompression resistant (EDR) O’rings, these are supported by a secondary graphite seal which ensure reliable operation at high levels of sealing integrity when operating the valve.
- ⑧ Seats & stem emergency sealant injection (4” & larger): Valves are supplied with emergency sealant Injectors located between the double O’ring arrangement of the seat assembly & stem seal area. A highly viscous sealant is injected through these fittings to restore closure integrity.*Whenever the valve lifetime has ended or if any of the seats get damaged, the emergency sealant injection system may temporarily be used to achieve tightness before maintenance takes place.
- ⑨ Antistatic device: An inconel spring is placed between body, ball and stem to prevent static continuity.
- ⑩ Block & bleed: Double block & bleed is achieved with the valve in two positions either fully closed or fully opened.
- ⑪ Lever handle: 6” & larger valves supplied with gear operator.

TRUNNION MOUNTED BALL VALVE BOLTED BODY, CLASS 1500 (LEVER OPERATED)

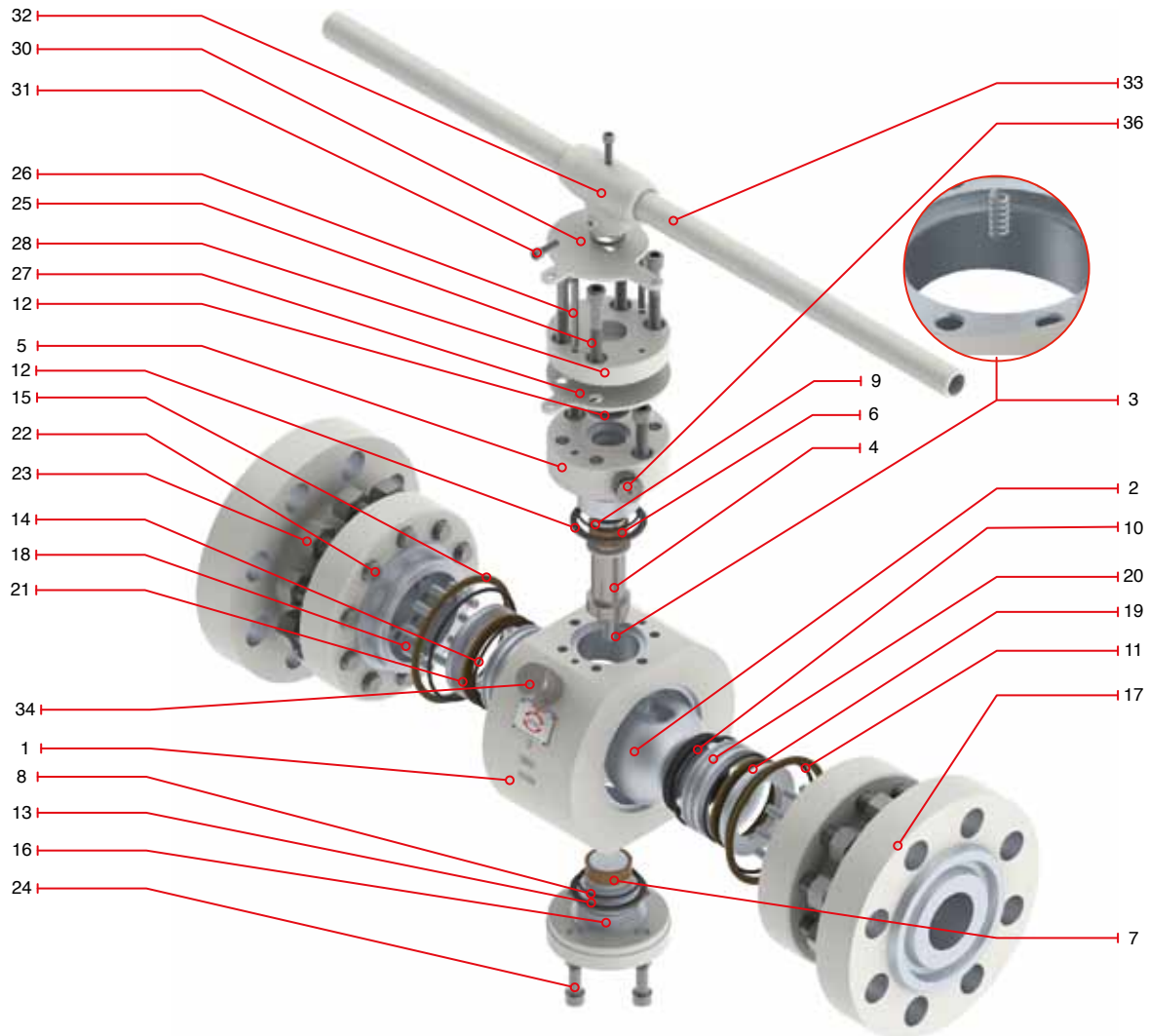

Regular Bill of Materials

No.	Description	ASTM Materials	No.	Description	ASTM Materials
1	Body	ASTM A105N	21	Seat insert	RPTFE
2	Ball	ASTM A105+75µm ENP / AISI 410	22	Stud	ASTM A193 B7M
3	Antistatic spring	INCONEL X-750	23	Nut	ASTM A194 2HM
4	Stem	AISI 4140+75µm ENP / AISI 410	24	Bottom socket screw	ASTM A193 B7M
5	Trunnion / bonnet	AISI 4140+75µm ENP	25	Top socket screw	ASTM A193 B7M
6	Upper bearing	C.S.+ PTFE LINING	26	Pin	Carbon Steel
7	Lower bearing	C.S.+ PTFE LINING	27	Locking device	A36
8	Lower O'ring	Viton	28	Packing gland flange	ASTM A216 WCB / A105
9	Stem O'ring	Viton	29	Hex. Bolt*	ASTM A193 B7M
10	On seat O'ring*	Viton	30	Stop plate	A36
11	Back up O'ring	Viton	31	Retainer	AISI 1070
12	Upper fire safe gasket	Graphite	32	Handle nut	ASTM A216 WCB
13	Lower fire safe gasket	Graphite	33	Handle	ASTM A53
14	On seat fire safe gasket	Graphite	34	Vent valve	Carbon Steel
15	Ends flange fire safe gasket	Graphite	35	Drain plug	Carbon Steel
16	Lower trunnion	AISI 4140+75µm ENP / AISI 410	36	Stem grease fitting	AISI 4140
17	Flanged ends	A105N	37	Flanged end grease fitting*	AISI 4140
18	Seat spring	INCONEL X-750	38	Lifting lug*	A36
19	Back up seat ring*	ASTM A105+75µm ENP / AISI 410	39	Support leg*	A36
20	Seat ring	ASTM A105+75µm ENP / AISI 410			

* Not shown

TRUNNION MOUNTED BALL VALVE BOLTED BODY, CLASS 1500 (LEVER OPERATED)

Design Features

- Side entry
- Blow out proof stem
- Soft & metal - metal seats
- Gear operated from 6" and up starting from Class 1500 #
- Three piece forged body design
- Bleed valve
- Fire safe packing
- Lifting lugs
- Heavy wall thickness
- Secondary seat injection sealant
- Draining plug



Catalog Figure No.	Type of Ends
8512	Raised Face (RF)
8513	Ring Type Joint (RTJ)
8514	Buttweld (WE)

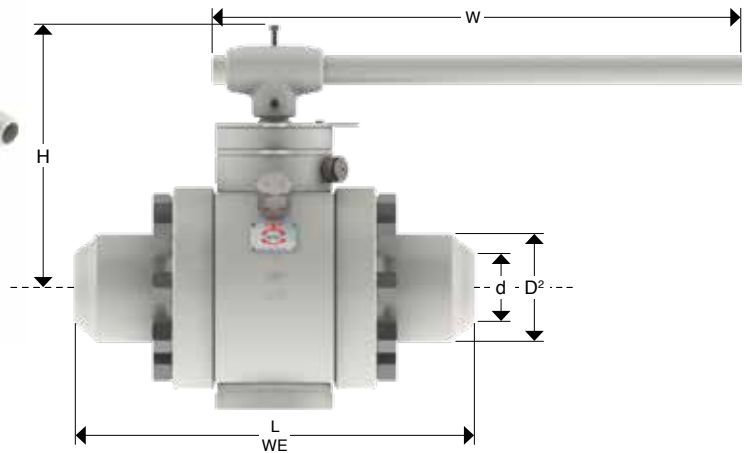
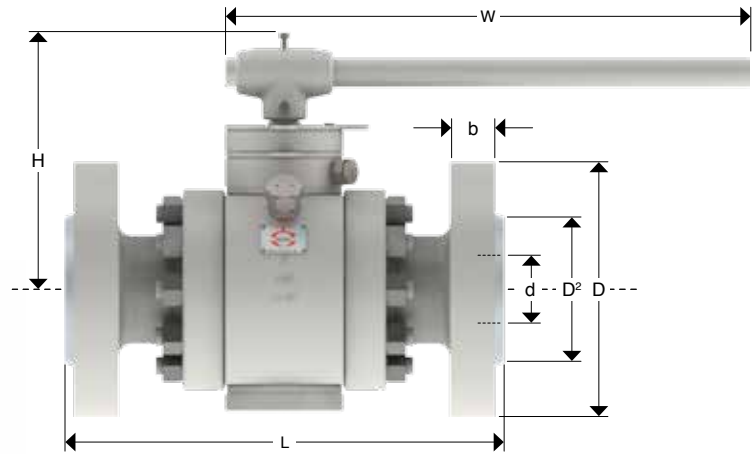

Dimensions and Weights

Nominal Diameter	mm	50	65	80
	in	2"	2 ½"	3"
d	mm	49	62	74
	in	1.93	2.44	2.91
D	mm	216	244	267
	in	8.50	9.61	10.51
D2	mm	92	105	127
	in	3.62	4.13	5
b	mm	38.5	41.5	48
	in	1.52	1.63	1.89
L	mm	368	419	470
	in	14.50	16.50	18.50
L (WE)	mm	368	419	381
	in	14.50	16.50	14.02
H	mm	212	220	233
	in	8.37	8.68	9.19
ØW	mm	700	800	900
	in	27.56	23.62	35.43
Weight	kg	65	93	115
(RF - RTJ)	Lb	143	205	254

Key Parameters

Code	Name
d	Bore diameter
D	Flange diameter
D2	Raised face diameter
b	Flange thickness
L	Raised face and ring type joint face to face
L (WE)	Welded end face to face
H	Height
ØW	Handwheel diameter
Weight	Weight

TRUNNION MOUNTED BALL VALVE BOLTED BODY, CLASS 1500 (GEAR OPERATED)

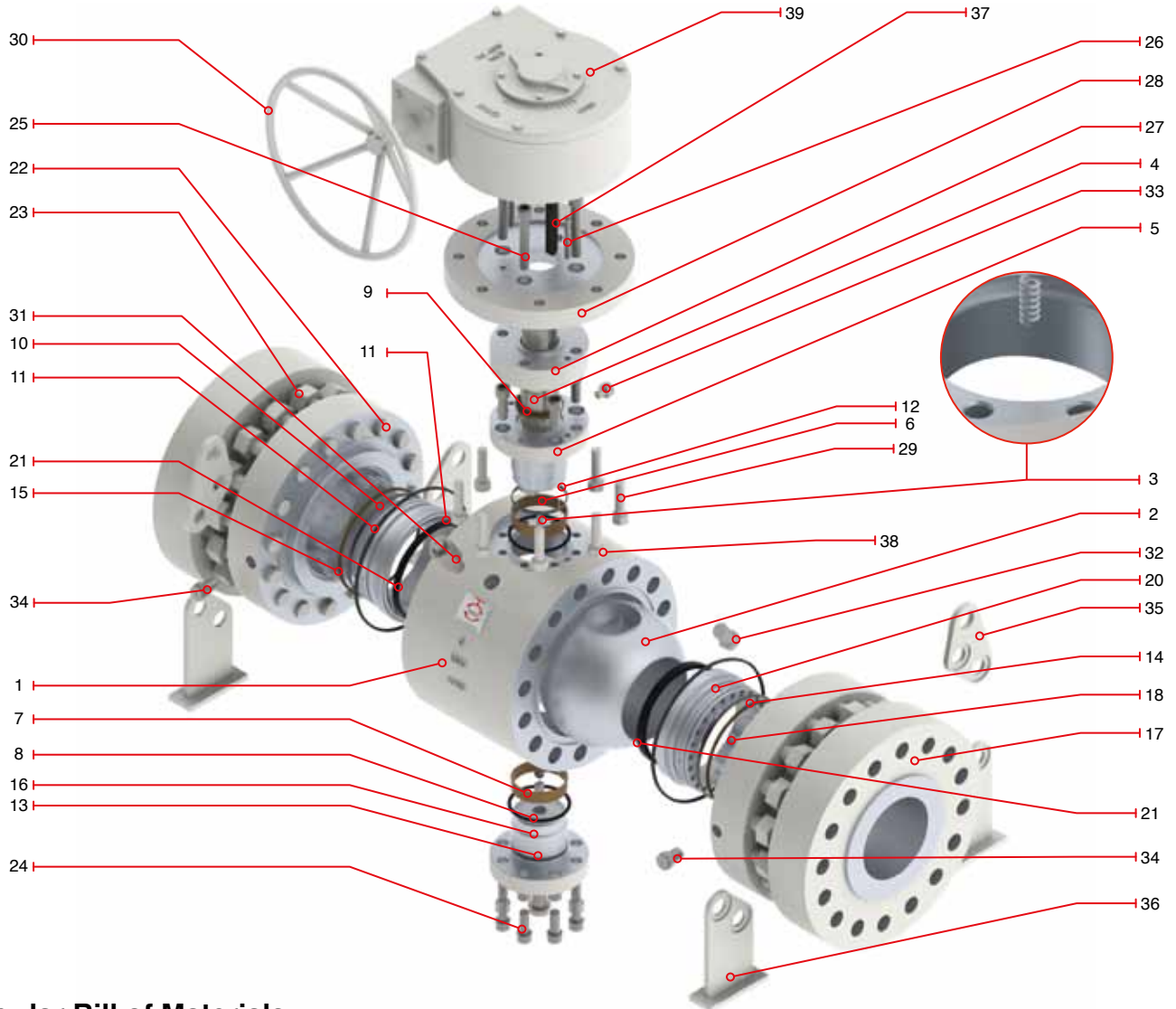

Regular Bill of Materials

No.	Description	ASTM Materials	No.	Description	ASTM Materials
1	Body	ASTM A105N	21	Seat insert	RPTFE
2	Ball	ASTM A105+75µm ENP / AISI 410	22	Stud	ASTM A193 B7M
3	Antistatic spring	INCONEL X-750	23	Nut	ASTM A194 2HM
4	Stem	AISI 4140+75µm ENP / AISI 410	24	Bottom socket screw	ASTM A193 B7M
5	Trunnion / bonnet	AISI 4140+75µm ENP	25	Top socket screw	ASTM A193 B7M
6	Upper bearing	C.S.+ PTFE LINING	26	Pin	ASTM A276 T410
7	Lower Bearing	C.S.+ PTFE LINING	27	Packing gland bushing*	AISI 410
8	Lower O'ring	Viton	28	Packing gland flange	ASTM A216 WCB / A105
9	Stem O'ring	Viton	29	Hex. Bolt	ASTM A193 B7M
10	Seat O'ring	Viton	30	Handwheel	ASTM A53
11	Back up O'ring	Viton	31	Vent valve	AISI 4140
12	Upper fire safe gasket	Graphite	32	Drain plug	AISI 4140
13	Lower fire safe gasket	Graphite	33	Stem grease fitting*	AISI 4140
14	On seat fire safe gasket	Graphite	34	Ends grease fitting	AISI 4140
15	Fire safe gasket	Graphite	35	Lifting lug	A36
16	Lower trunnion	AISI 4140+75µm ENP / AISI 410	36	Support leg	A36
17	Flanged ends	A105N	37	Key	Carbon Steel
18	Seat spring	INCONEL X-750	38	Spring lock washer	Carbon Steel
19	Back up seat ring	ASTM A105+75µm ENP / AISI 410	39	Gear box	Commercial steel
20	Seat ring	ASTM A105+75µm ENP / AISI 411			

* Not shown

TRUNNION MOUNTED BALL VALVE BOLTED BODY, CLASS 1500 (GEAR OPERATED)

Design Features

- Side entry
- Blow out proof stem
- Soft & metal - metal seats
- Gear operated from 6" and up starting from Class 1500 #
- Three piece forged body design
- Bleed valve
- Fire safe packing
- Lifting lugs
- Heavy wall thickness
- Secondary seat injection sealant
- Draining plug



Catalog Figure No.	Type of Ends
8522	Raised Face (RF)
8523	Ring Type Joint (RTJ)
8524	Buttweld (WE)

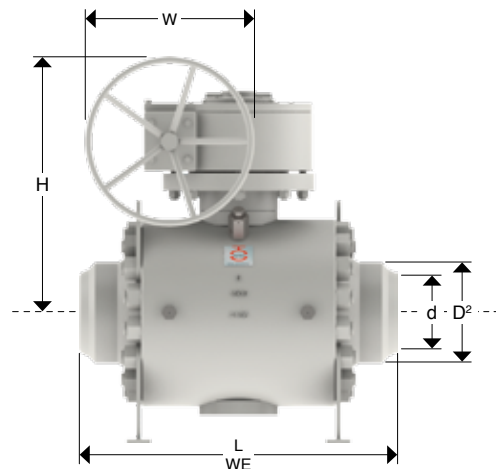
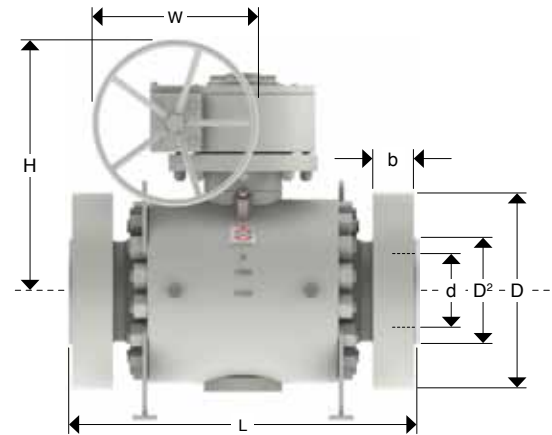

Dimensions and Weights

Nominal Diameter	mm	100	150	200	250	300	350	400	450	500	600
	in	4"	6"	8"	10"	12"	14"	16"	18"	20"	24"
d	mm	100	144	192	239	287	315	360	406	454	546
	in	3.94	5.67	7.56	9.41	11.30	12.40	14.17	15.98	17.87	21.50
D	mm	311	394	483	585	674	750	825	914	985	1168
	in	12.24	15.51	19.02	23.03	26.54	29.53	32.48	35.98	38.78	45.98
D2	mm	157	216	270	324	381	413	470	533	584	692
	in	6.18	8.50	10.63	12.76	15	16.26	18.50	20.98	23	27.24
b	mm	54	83	92	108	124	134	146.5	162	178	204
	in	2.13	3.27	3.62	4.25	4.88	5.28	5.77	6.38	7.01	8.03
L	mm	546	705	832	991	1130	1257	1384	1537	1664	1943
	in	21.50	27.76	32.76	39.02	44.49	49.49	54.49	60.51	65.51	76.50
L (WE)	mm	457	610	737	838	968	1029	1130	1219	1321	1549
	in	18	24.02	29.02	33	38	40.51	44.49	43	52.01	60.98
H	mm	275	690	758	824	856	775	937	1030	1080	1295
	in	10.84	27.17	29.84	32.44	33.7	30.51	36.89	40.55	42.52	51
ØW	mm	600	800	800	800	800	600	800	800	800	800
	in	23.62	31.50	31.50	31.50	31.50	23.62	31.50	31.50	31.50	31.50
Weight	kg	195	495	870	1520	2250	3200	4400	6035	8077	12357
(RF - RTJ)	Lb	429	1091	1918	3351	4960	7055	9700	13304	17806	27242

TRUNNION MOUNTED BALL VALVE BOLTED BODY, CLASS 2500

Trunnion Mounted Ball Valves are designed and manufactured in conformance with API 6D, ISO 14313, ASME B16.34, API 6FA, API 607 & NACE MR01-75.

Design Features

- Sizes NPS (DN): 2”(50mm) to 48”(1200mm)
- ASME class: 2500 #
- Temperature Ratings: -29°C to 121°C (Standard)
- Design: API 6D/ISO14313, ASME B16.34
- Face to face, end to end: API 6D, ASME B16.10
- Butt weld ends: ASME B16.25
- Test: API 6D, API 598, ISO 5208
- Fire test: API 6FA, BS6755, API607
- Sour environments: NACE MR-01-75
- Seals area overlay: On request

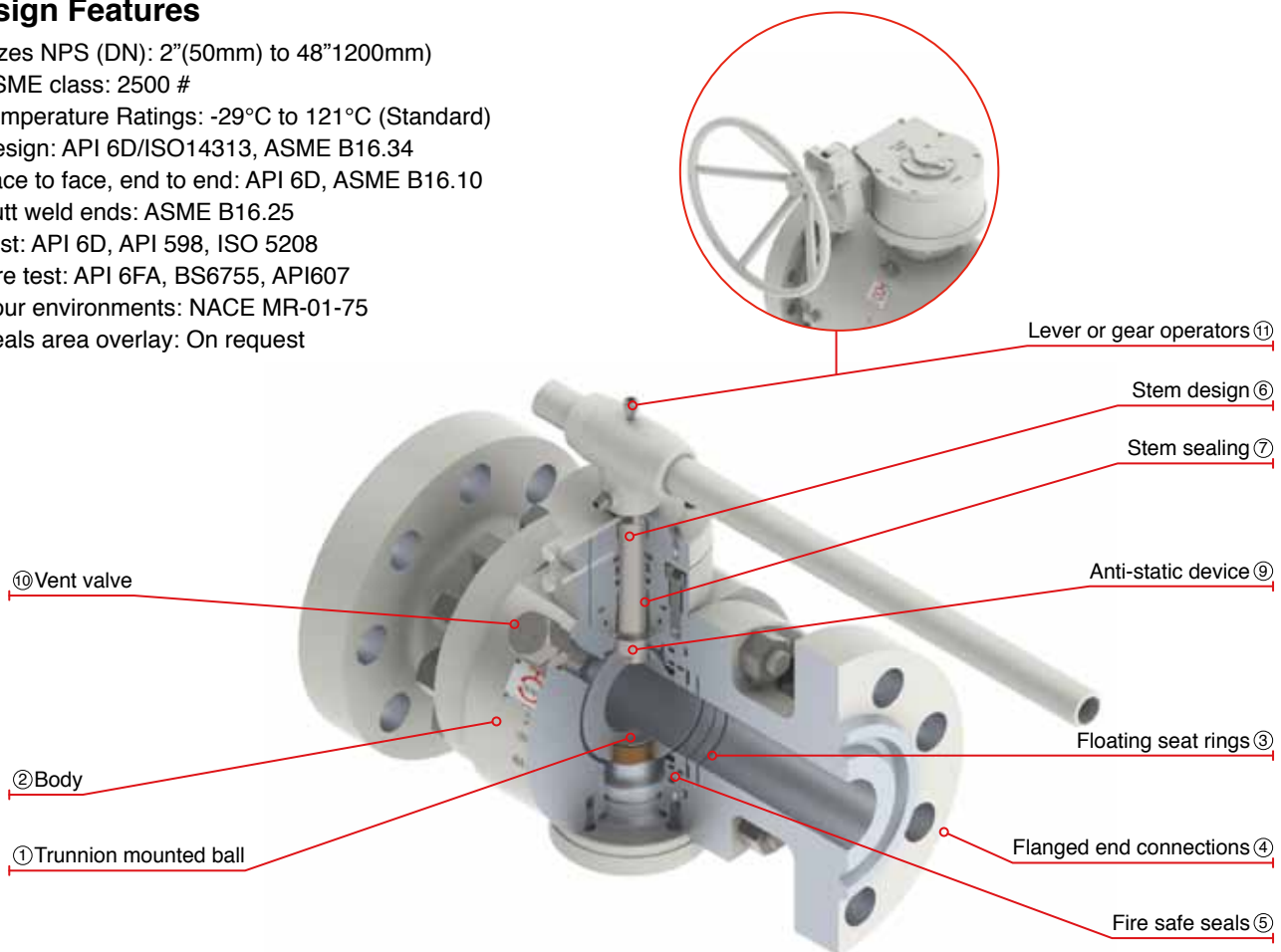

- ① Trunnion mounted ball: For all sizes & pressure ratings. The ball is fixed by an upper & lower trunnion, seat rings are dynamic which will move freely along the horizontal axis.
- ② Body. Three piece forged steel body for easy disassembly on site. Small cavities between body, seats & ball minimize the quantity of fluid that could get stored in that hollow space.
- ③ Floating seat rings. Two independent dynamic seat rings attain Bi-Directional closure of the valve these Seat. Rings are spring loaded that achieve tight shut-off at considerable low differential pressure.
- ④ Flanged ends connections. Forged steel RF or RTJ connections according to ASME B16.5 up to 24” and ASME B16.47 Series A for 26” & larger.
- ⑤ Fire safe seals: Fire safe design prevents leakage when the elastomeric seals are exposed to very high temperatures.
- ⑥ Stem design: Bottom entry anti blow out stem is made of one piece which is held up by the valve body. It has been design to avoid any possible projection due to hazardous conditions.
- ⑦ Stem sealing: Accurate machining process together with electro less nickel plated (ENP) double explosive decompression resistant (EDR) O’rings, these are supported by a secondary graphite seal which ensure reliable operation at high levels of sealing integrity when operating the valve.
- ⑧ Seats & stem emergency sealant injection (4” & larges): Valves are supplied with emergency sealant Injectors located between the double O’ring arrangement of the seat assembly & stem seal area. A highly viscous sealant is injected through these fittings to restore closure integrity.*Whenever the valve lifetime has ended or if any of the seats get damaged, the emergency sealant injection system may temporarily be used to achieve tightness before maintenance takes place.
- ⑨ Antistatic device: An inconel spring is placed between body, ball and stem to prevent static continuity.
- ⑩ Block & bleed: Double block & bleed is achieved with the valve in two positions either fully closed or fully opened.
- ⑪ Lever handle: 6” & larger valves supplied with gear operator.

TRUNNION MOUNTED BALL VALVE BOLTED BODY, CLASS 2500 (LEVER OPERATED)

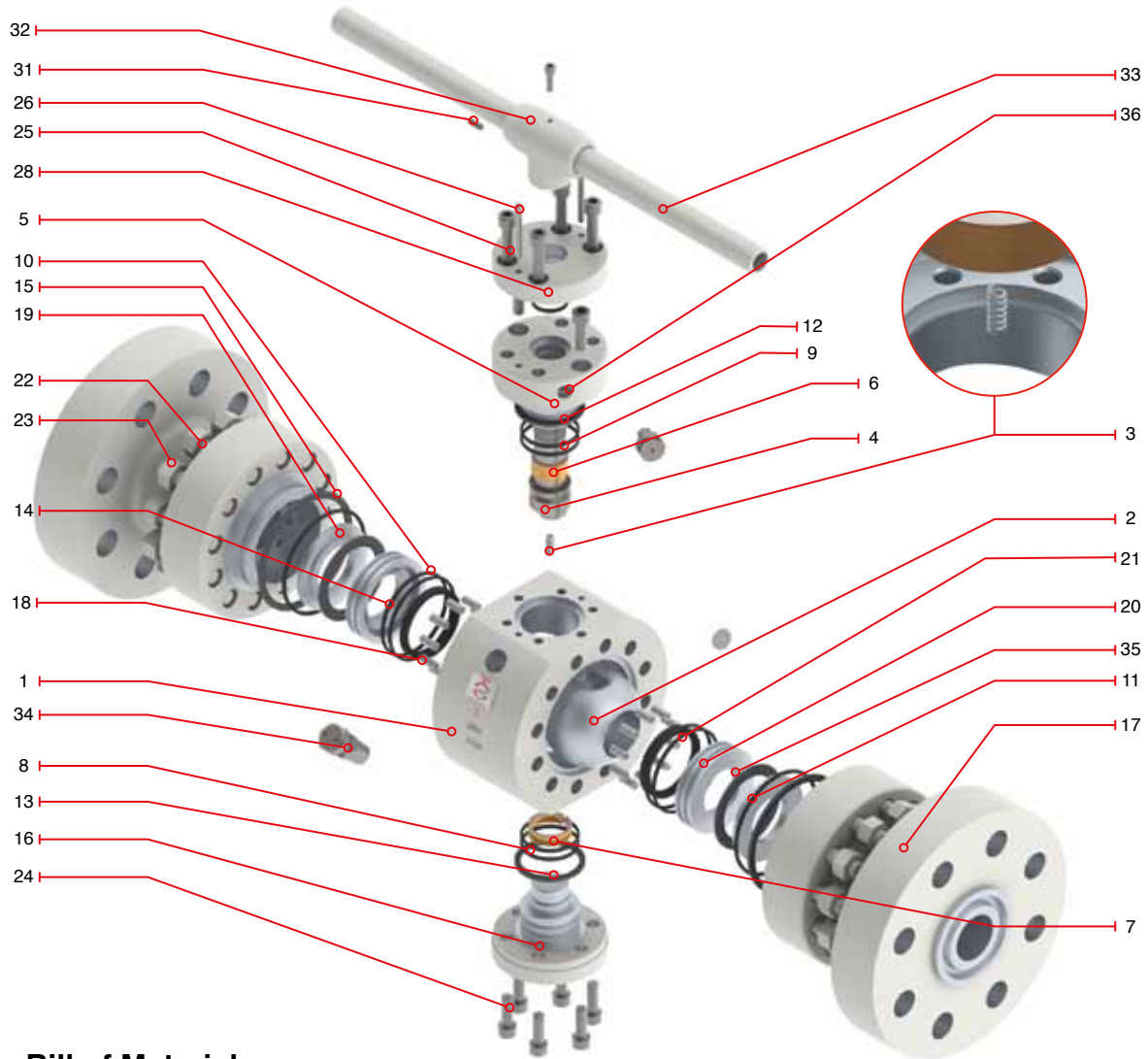

Regular Bill of Materials

No.	Description	ASTM Materials	No.	Description	ASTM Materials
1	Body	ASTM A105N	21	Seat insert	RPTFE
2	Ball	ASTM A105+75µm ENP / AISI 410	22	Stud	ASTM A193 B7M
3	Antistatic spring	INCONEL X-750	23	Nut	ASTM A194 2HM
4	Stem	AISI 4140+75µm ENP / AISI 410	24	Bottom socket screw	ASTM A193 B7M
5	Trunnion / bonnet	AISI 4140+75µm ENP	25	Top socket screw	ASTM A193 B7M
6	Upper bearing	C.S.+ PTFE LINING	26	Pin	Carbon Steel
7	Lower bearing	C.S.+ PTFE LINING	27	Locking device*	A36
8	Lower O'ring	Viton	28	Packing gland flange	ASTM A216 WCB / A105
9	Stem O'ring	Viton	29	Hex. Bolt*	ASTM A193 B7M
10	On seat O'ring*	Viton	30	Stop plate*	A36
11	Back up O'ring	Viton	31	Retainer	AISI 1070
12	Upper fire safe gasket	Graphite	32	Handle nut	ASTM A216 WCB
13	Lower fire safe gasket	Graphite	33	Handle	ASTM A53
14	On seat fire safe gasket	Graphite	34	Vent valve	Carbon Steel
15	Ends flange fire safe gasket	Graphite	35	Drain plug	Carbon Steel
16	Lower trunnion	AISI 4140+75µm ENP / AISI 410	36	Stem grease fitting	AISI 4140
17	Flanged ends	A105N	37	Flanged end grease fitting*	AISI 4140
18	Seat spring	INCONEL X-750	38	Lifting lug*	A36
19	Back up seat ring*	ASTM A105+75µm ENP / AISI 410	39	Support leg*	A36
20	Seat ring	ASTM A105+75µm ENP / AISI 410			

* Not shown

TRUNNION MOUNTED BALL VALVE BOLTED BODY, CLASS 2500 (LEVER OPERATED)

Design Features

- Side entry
- Blow out proof stem
- Soft & metal - metal seats
- Gear operated from 6" and up starting from Class 2500 #
- Three piece forged body design
- Bleed valve
- Fire safe packing
- Lifting lugs
- Heavy wall thickness
- Secondary seat injection sealant
- Draining plug



Catalog Figure No.	Type of Ends
8213	Ring Type Joint (RTJ)
8214	Buttweld (WE)

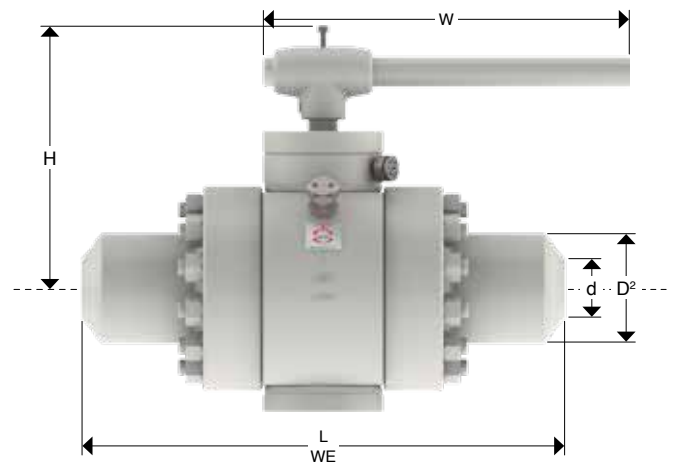
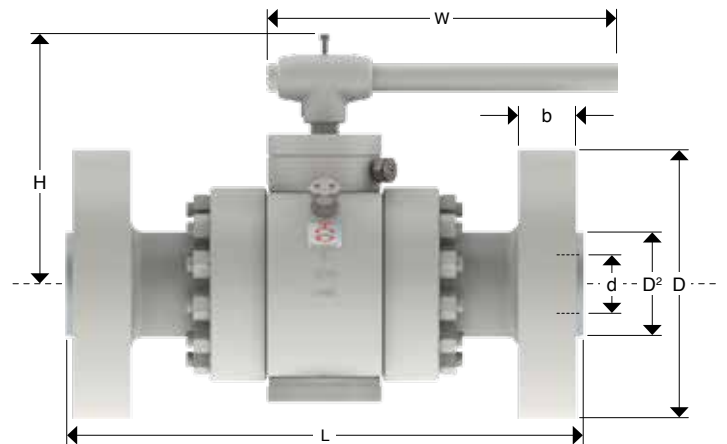

Dimensions and Weights

Nominal Diameter	mm in	50 2"	65 2 1/2"	80 3"
d	mm inch	42 1.65	52 2.05	62 2.44
D	mm inch	235 9.25	267 10.51	305 12.01
D2	mm inch	133 5.24	149 5.87	168 6.61
P	mm inch	101.6 4	111.12 4.37	127 5
E	mm inch	7.92 0.31	9.52 0.37	9.52 0.37
b	mm inch	51 2.01	58 2.28	67 2.64
L	mm inch	454 17.87	514 20.24	584 23
L (WE)	mm inch	222 8.76	240 9.46	259 10.21
H	mm inch	800 31.50	900 35.43	1000 39.37
ØW	mm inch	800 31.50	900 35.43	1000 39.37
Weight	Kg. Lb.	POA	POA	POA

Key Parameters

Code	Name
d	Bore diameter
D	Flange diameter
D2	Raised face diameter
b	Flange thickness
L	Raised face and ring type joint face to face
L (WE)	Welded end face to face
H	Height
ØW	Handwheel diameter
Weight	Weight

TRUNNION MOUNTED BALL VALVE BOLTED BODY, CLASS 2500 (GEAR OPERATED)

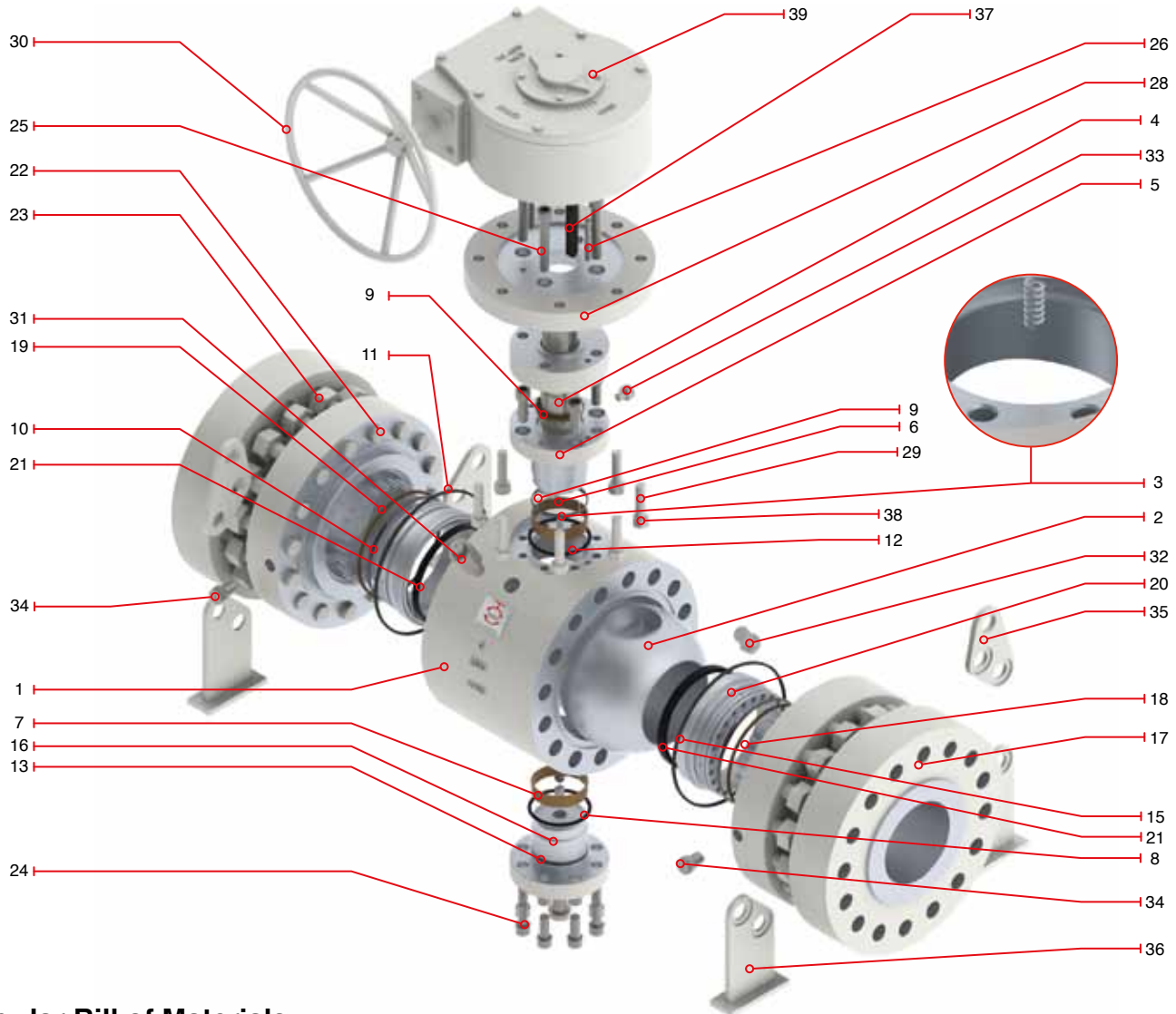

Regular Bill of Materials

No.	Description	ASTM Materials	No.	Description	ASTM Materials
1	Body	ASTM A105N	21	Seat insert	RPTFE
2	Ball	ASTM A105+75µm ENP / AISI 410	22	Stud	ASTM A193 B7M
3	Antistatic spring	INCONEL X-750	23	Nut	ASTM A194 2HM
4	Stem	AISI 4140+75µm ENP / AISI 410	24	Bottom socket screw	ASTM A193 B7M
5	Trunnion / bonnet	AISI 4140+75µm ENP	25	Top socket screw	ASTM A193 B7M
6	Upper bearing	C.S.+ PTFE LINING	26	Pin	ASTM A276 T410
7	Lower Bearing	C.S.+ PTFE LINING	27	Packing gland bushing*	AISI 410
8	Lower O'ring	Viton	28	Packing gland flange	ASTM A216 WCB / A105
9	Stem O'ring	Viton	29	Hex. Bolt	ASTM A193 B7M
10	Seat O'ring	Viton	30	Handwheel	ASTM A53
11	Back up O'ring	Viton	31	Vent valve	AISI 4140
12	Upper fire safe gasket	Graphite	32	Drain plug	AISI 4140
13	Lower fire safe gasket	Graphite	33	Stem grease fitting*	AISI 4140
14	On seat fire safe gasket	Graphite	34	Ends grease fitting	AISI 4140
15	Fire safe gasket	Graphite	35	Lifting lug	A36
16	Lower trunnion	AISI 4140+75µm ENP / AISI 410	36	Support leg	A36
17	Flanged ends	A105N	37	Key	Carbon Steel
18	Seat spring	INCONEL X-750	38	Spring lock washer	Carbon Steel
19	Back up seat ring*	ASTM A105+75µm ENP / AISI 410	39	Gear box	Commercial steel
20	Seat ring	ASTM A105+75µm ENP / AISI 411			

* Not shown

TRUNNION MOUNTED BALL VALVE BOLTED BODY, CLASS 2500 (GEAR OPERATED)

Design Features

- Side entry
- Blow out proof stem
- Soft & metal - metal seats
- Gear operated from 6" and up starting from Class 2500 #
- Three piece forged body design
- Bleed valve
- Fire safe packing
- Lifting lugs
- Heavy wall thickness
- Secondary seat injection sealant
- Draining plug



Catalog Figure No.	Type of Ends
8223	Ring Type Joint (RTJ)
8224	Buttweld (WE)

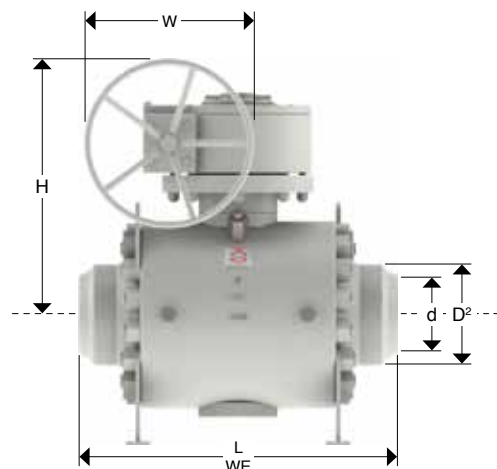
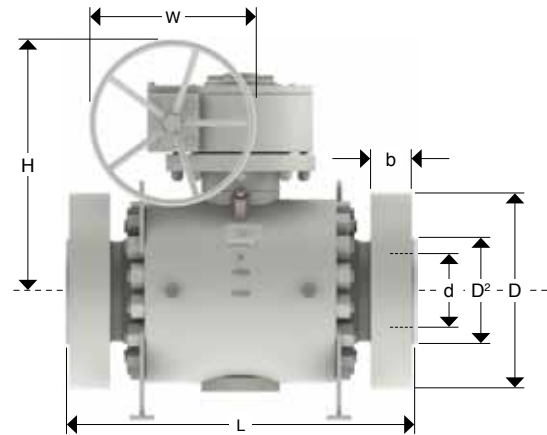

Dimensions and Weights

D Nominal Diameter	mm	100 4"	150 6"	200 8"	250 10"	300 12"
d	mm	87	131	179	223	265
	inch	3.43	5.16	7.05	8.78	10.43
D	mm	356	483	552	674	762
	inch	14.02	19.02	21.73	26.54	30
D2	mm	203	279	340	426	495
	inch	8	10.98	13.39	16.77	19.49
P	mm	157.18	228.6	279.4	342.9	406.4
	inch	6.19	9	11	13.50	16
E	mm	11.13	12.7	14.27	17.48	17.48
	inch	0.44	0.50	0.56	0.69	0.69
b	mm	76.5	108	127	165	185
	inch	3.01	4.25	5	6.50	7.28
L	mm	683	927	1038	1292	1445
	inch	26.89	36.50	40.87	50.87	56.89
L (WE)	mm	319	778	850	960	1080
	inch	12.57	30.63	33.47	37.80	42.52
H	mm	600	800	800	800	800
	inch	23.62	31.50	31.50	31.50	31.50
ØW	mm	600	800	800	800	800
	inch	23.62	31.50	31.50	31.50	31.50
Weight	Kg. Lb.	POA	POA	POA	POA	POA

Key Parameters

Code	Name
d	Bore diameter
D	Flange diameter
D2	Raised face diameter
b	Flange thickness
L	Raised face and ring type joint face to face
L (WE)	Welded end face to face
H	Height
ØW	Handwheel diameter
Weight	Weight

TRUNNION MOUNTED BALL VALVE WELDED BODY, CLASS 150

Welded Body Ball Valves Metal-to-Metal Seated: Gives it maximum strength and minimum weight and reduce leak possibilities. Are designed and manufactured for Abrasive Service in conformance with the specification of API 6D, ISO 14313, ASME B16.34, ASME B16.25, API 6FA, API 607 & ISO 15156 / NACE MR01-75.

Design Features

- Sizes NPS (DN): 2”(50mm) to 48”(1200mm)
- ASME Class: 150 #
- Temperature ratings: -50°C to 121°C (standard design)
- Design: API 6D/ISO14313, ASME B16.34
- Face to face, end to end: API 6D, ASME B16.10
- Butt weld ends: ASME B16.25
- Test: API 6D, API 598, ISO 5208
- Fire test: API 6FA, BS6755, API607
- Sour environments: NACE MR-01-75
- Seals area overlay: Upon request

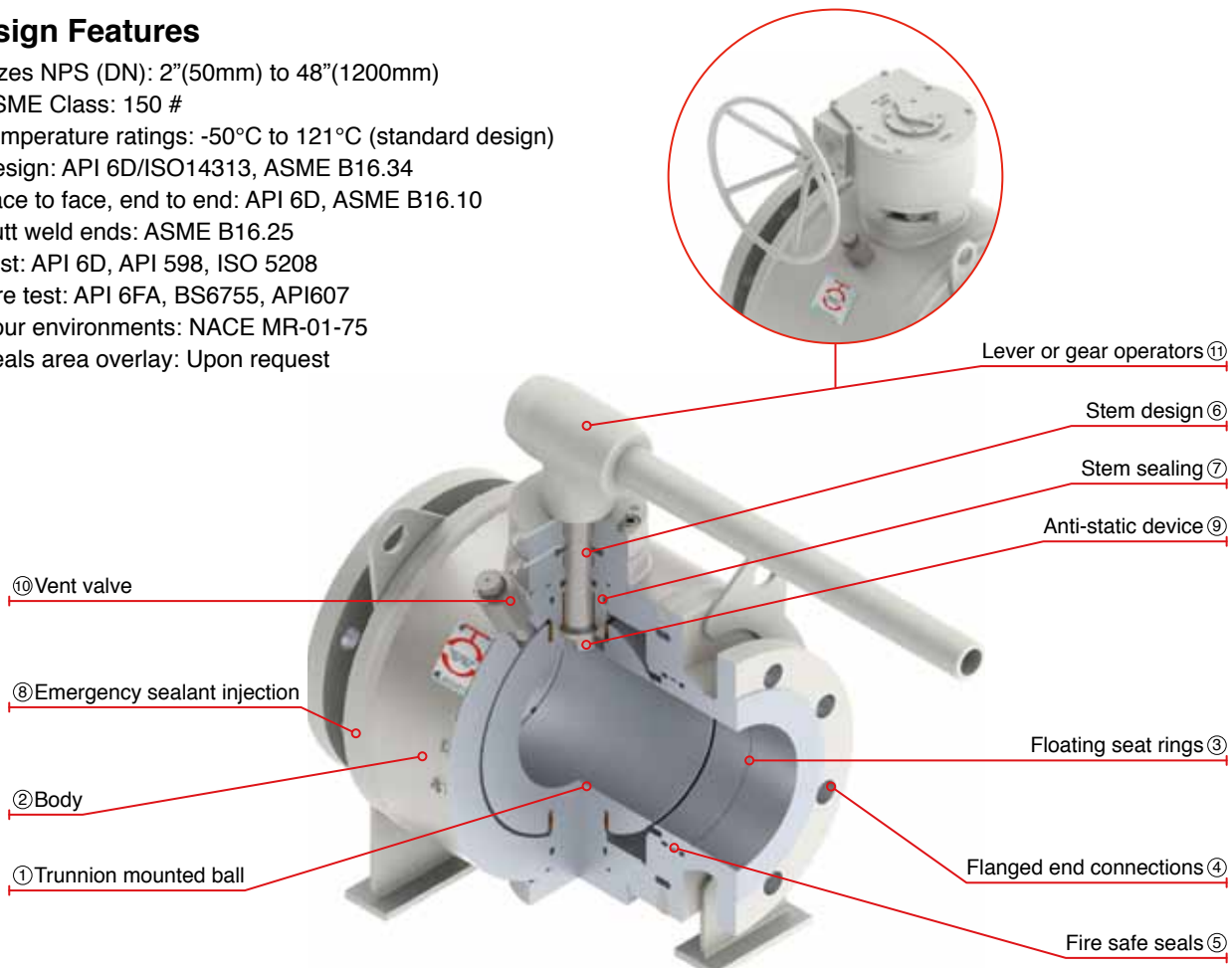

- ① Trunnion mounted ball: For all sizes & pressure ratings. The ball is fixed by an upper & lower trunnion, seat rings are dynamic which will move freely along the horizontal axis.
- ② Welded Body. Engineered and manufactured particularly for heavy-duty services, such feature allows maximum strength it also saves material which makes it lighter than the flanged model its compact design eliminates body flanges weight reducing the possibility of any leakage.
- ③ Floating seat rings. Two independent dynamic seat rings attain Bi-Directional closure of the valve these Seat. Rings are spring loaded that achieve tight shut-off at considerable low differential pressure.
- ④ Flanged ends connections. Forged steel RF or RTJ connections according to ASME B16.5 up to 24” and ASME B16.47 Series A for 26” & larger.
- ⑤ Fire safe seals: Fire safe design prevents leakage when the elastomeric seals are exposed to very high temperatures.
- ⑥ Stem design: Bottom entry anti blow out stem is made of one piece which is held up by the valve body. It has been design to avoid any possible projection due to hazardous conditions.
- ⑦ Stem sealing: Accurate machining process together with electro less nickel plated (ENP) coating control the hardness amongst stem, metallic components & double O’rings, these are supported by a secondary graphite seal which ensure reliable operation at high levels of sealing integrity when operating the valve.
- ⑧ Seats & stem emergency sealant injection (6” & Larges): Valves are supplied with emergency sealant Injectors located between the double O’ring arrangement of the seat assembly & stem seal area. A highly viscous sealant is injected through these fittings to restore closure integrity.*Whenever the valve lifetime has ended or if any of the seats get damaged, the emergency sealant injection system may temporarily be used to achieve tightness before maintenance takes place.
- ⑨ Antistatic device: An inconel spring is placed between body, ball and stem to prevent static continuity.
- ⑩ Block & bleed: Double block & bleed is achieved with the valve in two positions either fully closed or fully opened.
- ⑪ Lever handle: 6” & larger valves supplied with gear operator.

TRUNNION MOUNTED BALL VALVE WELDED BODY, CLASS 150 (LEVER OPERATED)

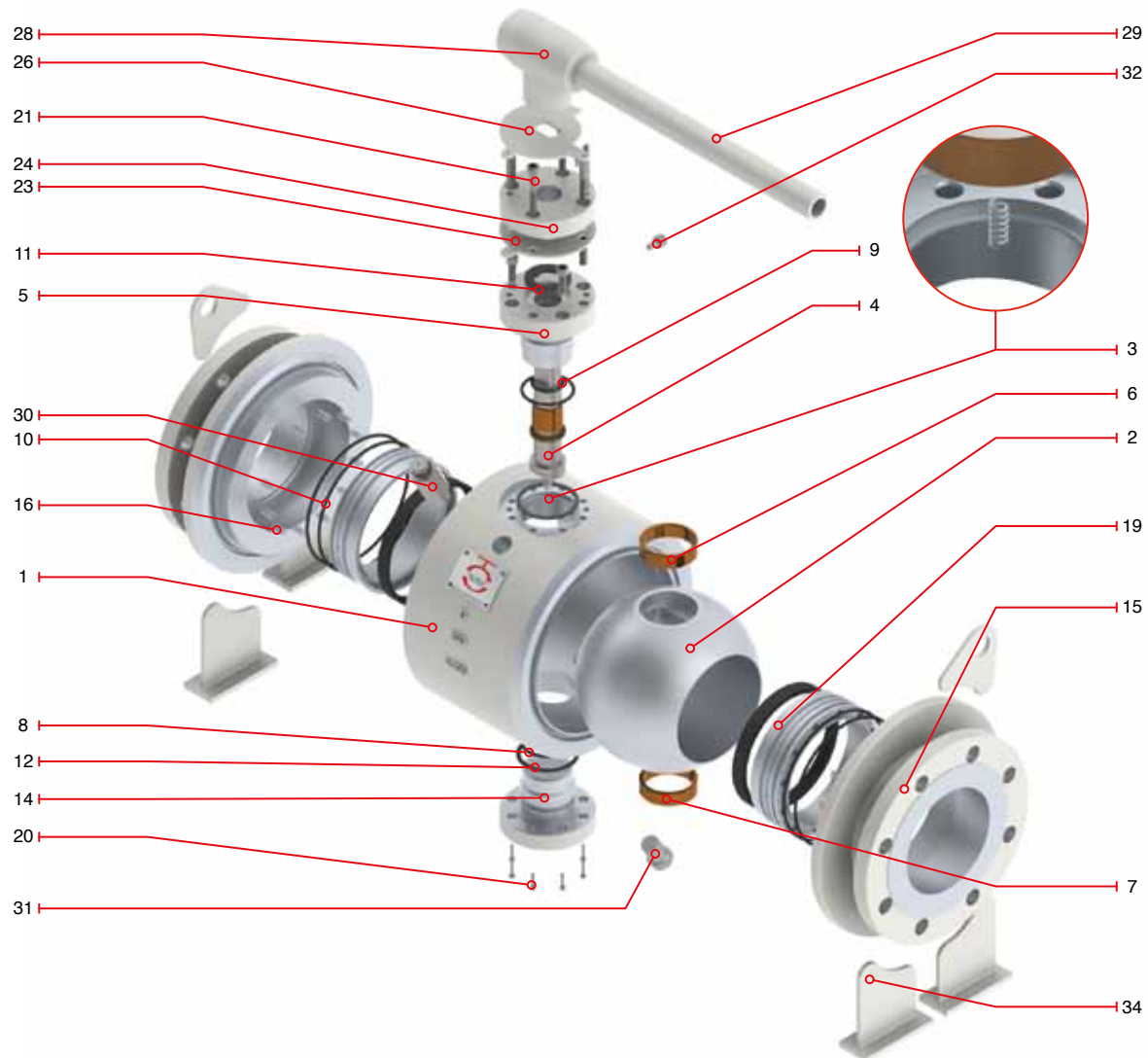

Regular Bill of Materials

No.	Description	ASTM Materials	No.	Description	ASTM Materials
1	Body	ASTM A105N	18	Seat ring	ASTM A105+75µm ENP / AISI 410
2	Ball	ASTM A105+75µm ENP / AISI 410	19	Seat insert	RPTFE
3	Antistatic spring	INCONEL X-750	20	Socket screw	ASTM A193 B7M
4	Stem	AISI 4140+75µm ENP / AISI 410	21	Socket screw	ASTM A193 B7M
5	Trunnion / bonnet	AISI 4140+75µm ENP	22	Pin	Carbon Steel
6	Upper bearing	C.S.+ PTFE LINING	23	Locking device	A36
7	Lower bearing	C.S.+ PTFE LINING	24	Packing gland flange	ASTM A216 WCB / A105
8	Lower O'ring	Viton	25	Hex. Bolt*	ASTM A193 B7M
9	Upper O'ring	Viton	26	Stop plate	A36
10	Seat O'ring	Viton	27	Retainer*	AISI 1070
11	Stem fire safe gasket	Graphite	28	Handle nut*	ASTM A216 WCB
12	Trunnion fire safe gasket	Graphite	29	Handle	ASTM A53
13	Seat fire safe gasket	Graphite	30	Vent valve	Carbon Steel
14	Trunnion	AISI 4140+75µm ENP / AISI 410	31	Drain plug	Carbon Steel
15	Flanged ends	A105N	32	Grease fitting*	Carbon Steel
16	Seat spring	INCONEL X-750	33	Lifting lug	A36
17	Back up seat ring*	ASTM A105+75µm ENP / AISI 410	34	Support leg	A36

* Not shown

TRUNNION MOUNTED BALL VALVE WELDED BODY, CLASS 150 (LEVER OPERATED)

Design Features

- Sizes NPS (DN): 2"(50mm) to 48"(1200mm)
- ASME Class: 150 #
- Temperature ratings: -50°C to 121°C (standard design)
- Design: API 6D/ISO14313, ASME B16.34
- Face to face, end to end: API 6D, ASME B16.10
- Butt weld ends: ASME B16.25
- Test: API 6D, API 598, ISO 5208
- Fire test: API 6FA, BS6755, API607
- Sour environments: NACE MR-01-75
- Seals area overlay: Upon request



Catalog Figure No.	Type of Ends
8112-W	Raised Face (RF)
8113-W	Ring Type Joint (RTJ)
8114-W	Buttweld (WE)

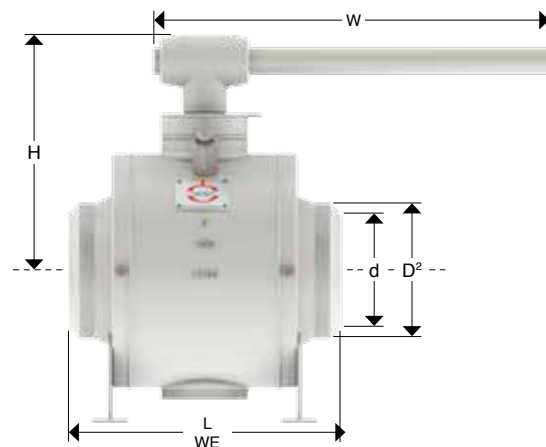
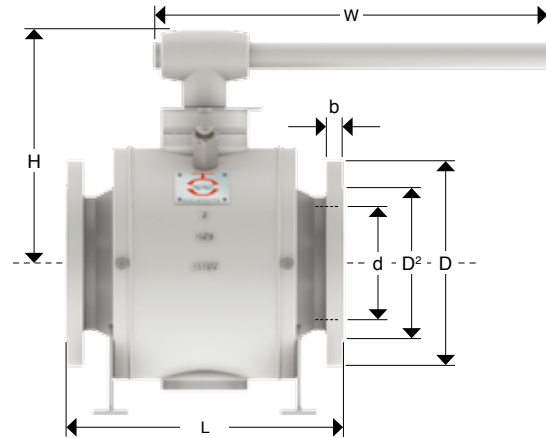

Dimensions and Weights

D Nominal Diameter	mm in	50 2"	65 2 1/2"	80 3"	100 4"
d	mm in	49 1.93	62 2.44	74 2.91	100 3.94
D	mm in	150 5.98	180 7	190 7.48	230 9.02
D2	mm in	92 3.62	105 4.13	127 5	157 6.18
b	mm in	16 0.63	18 0.71	19 0.75	24 0.94
L	mm in	178 7	191 7.48	203 8	229 9.02
L (WE)	mm in	216 8,5	241 9,48	283 11,14	305 12
H	mm in	172 6.79	210 8.28	241 9.50	275 10.84
ØW	mm in	*350 13.78	*350 13.78	*400 15.75	*450 17.72
Weight (RF - RTJ)	kg Lb	19.60 43.12	31.18 68.60	42.32 93.10	63.70 140.14

Key Parameters

Code	Name
d	Bore diameter
D	Flange diameter
D2	Raised face diameter
b	Flange thickness
L	Raised face and ring type joint face to face
L (WE)	Welded end face to face
H	Height
ØW	Handwheel diameter
Weight	Weight

TRUNNION MOUNTED BALL VALVE WELDED BODY, CLASS 150 (GEAR OPERATED)

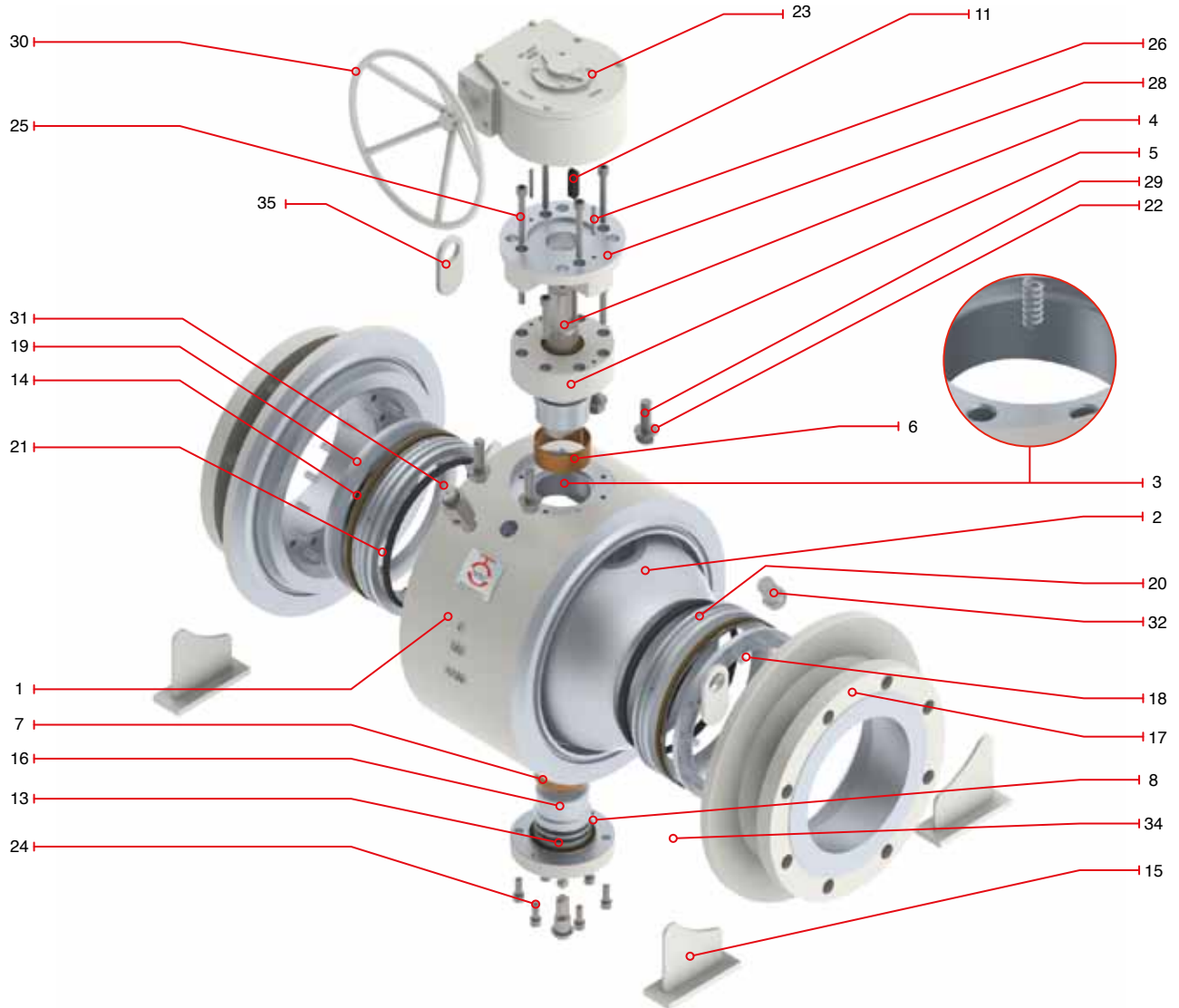

Regular Bill of Materials

No.	Description	ASTM Materials	No.	Description	ASTM Materials
1	Body	ASTM A105N	19	Back up seat ring	ASTM A105+75µm ENP / AISI 410
2	Ball	ASTM A105+75µm ENP / AISI 410	20	Seat ring	ASTM A105+75µm ENP / AISI 411
3	Antistatic spring	INCONEL X-750	21	Seat insert	RPTFE
4	Stem	AISI 4140+75µm ENP / AISI 410	22	Spring lock washer	Carbon Steel
5	Trunnion / bonnet	AISI 4140+75µm ENP	23	Gear box	Commercial steel
6	Upper bearing	C.S.+ PTFE LINING	24	Bottom socket screw	ASTM A193 B7M
7	Lower Bearing	C.S.+ PTFE LINING	25	Top socket screw	ASTM A193 B7M
8	Lower O'ring*	Viton	26	Pin	ASTM A276 T410
9	Stem O'ring*	Viton	27	Packing gland bushing*	AISI 410
10	Seat O'ring*	Viton	28	Packing gland flange	ASTM A216 WCB / A105
11	Key	Carbon Steel	29	Hex. Bolt	ASTM A193 B7M
12	Upper fire safe gasket*	Graphite	30	Handwheel	ASTM A53
13	Lower fire safe gasket	Graphite	31	Vent valve	AISI 4140
14	On seat fire safe gasket	Graphite	32	Drain plug	AISI 4140
15	Support leg	A36	33	Stem grease fitting*	AISI 4140
16	Lower trunnion	AISI 4140+75µm ENP / AISI 410	34	Ends grease fitting*	AISI 4140
17	Flanged ends	A105N	35	Lifting lug	A36
18	Seat spring	INCONEL X-750			

* Not shown

TRUNNION MOUNTED BALL VALVE WELDED BODY, CLASS 150 (GEAR OPERATED)

Design Features

- Side entry
- Blow out proof stem
- Soft & metal - metal seats
- Gear operated from 6" and up starting from Class 150 #
- Three piece forged body design
- Bleed valve
- Fire safe packing
- Lifting lugs
- Heavy wall thickness
- Secondary seat injection sealant
- Draining plug



Catalog Figure No.	Type of Ends
8122-W	Raised Face (RF)
8123-W	Ring Type Joint (RTJ)
8124-W	Buttweld (WE)

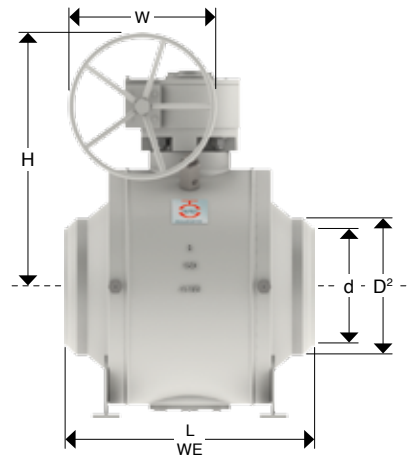
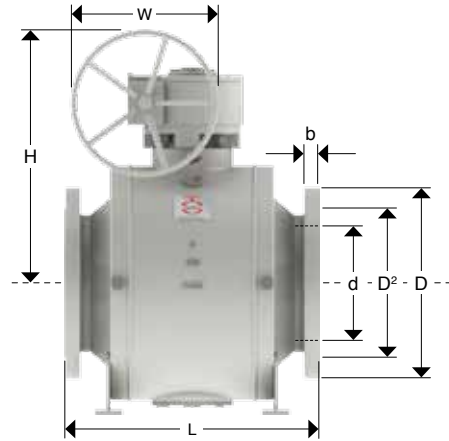

Dimensions and Weights

D Nominal Diameter	mm in	150	200	250	300	350	400	450	500	610	660	711	762	813	864	914
		6"	8"	10"	12"	14"	16"	18"	20"	24"	26"	28"	30"	32"	34"	36"
d	mm	150	201	252	303	334	385	436	487	589	633	684	735	779	830	874
	in	5.91	7.91	9.92	11.93	13.15	15.16	17.17	19.17	23.19	24.92	26.92	28.93	30.66	32.67	34.40
D	mm	280	345	405	485	535	595	635	700	815	870	925	985	1060	1110	1170
	in	10.98	13.50	15.98	19.02	20.98	23.50	25	27.52	32.01	34.25	32.01	36.41	41.73	43.70	46.06
D2	mm	216	270	324	381	413	470	533	584	692	749	800	857	914	965	1022
	in	8.50	10.63	12.76	15	16.26	18.50	20.98	23	27.24	29.48	31.49	33.74	35.98	37.99	40.23
b	mm	26	29	31	32	33.4	35	38	41	46	67	70	73	80	81	89
	in	1.02	1.14	1.22	1.26	1.34	1.37	1.4	1.61	1.81	2.63	2.75	2.87	3.14	3.18	3.50
L	mm	394	457	568	648	686	762	864	914	1067	1143	1245	1295	1372	1473	1524
	in	15.51	18	20.98	24.02	27	30	34.02	35.98	42.01	45	49	50.98	54	57.99	60
L (WE)	mm	457	521	559	635	762	838	914	991	1143	1245	1346	1397	1524	1626	1727
	in	17.99	20.51	22	25	30	32.99	35.98	39	45	49	53	55	60	64	68
H	mm	590	657	824	856	875	937	1010	1090	1180	1180	1180	1180	1180	1180	1180
	in	23.23	25.9	32.44	33.7	34.45	36.89	39.77	42.92	46.46	46.46	46.46	46.46	46.46	46.46	46.46
ØW	mm	600	600	800	800	800	800	800	800	800	APM	APM	APM	APM	APM	APM
	in	23.62	23.62	31.50	31.50	31.50	31.50	31.50	31.50	31.50	APM	APM	APM	APM	APM	APM
Weight (RF - RTJ)	kg	171.95	274.85	451.69	648.14	942.58	1296.27	1679.36	2111.45	3221.08	3859.42	4419.35	5273.74	5833.23	6496.06	7404.35
	Lb	378.28	604.66	993.72	1425.90	2073.68	2851.80	3694.60	4645.20	7086.38	8490.72	9722.58	11602.22	12833.10	14291.34	16289.56

APM = As per manufacturer

TRUNNION MOUNTED BALL VALVE WELDED BODY, CLASS 300

Welded Body Ball Valves Metal-to-Metal Seated: Gives it maximum strength and minimum weight and reduce leak possibilities. Are designed and manufactured for Abrasive Service in conformance with the specification of API 6D, ISO 14313, ASME B16.34, ASME B16.25, API 6FA, API 607 & ISO 15156 / NACE MR01-75.

Design Features

- Sizes NPS (DN): 2”(50mm) to 48”(1200mm)
- ASME Class: 150 #
- Temperature ratings: -50°C to 121°C (standard design)
- Design: API 6D/ISO14313, ASME B16.34
- Face to face, end to end: API 6D, ASME B16.10
- Butt weld ends: ASME B16.25
- Test: API 6D, API 598, ISO 5208
- Fire test: API 6FA, BS6755, API607
- Sour environments: NACE MR-01-75
- Seals area overlay: Upon request

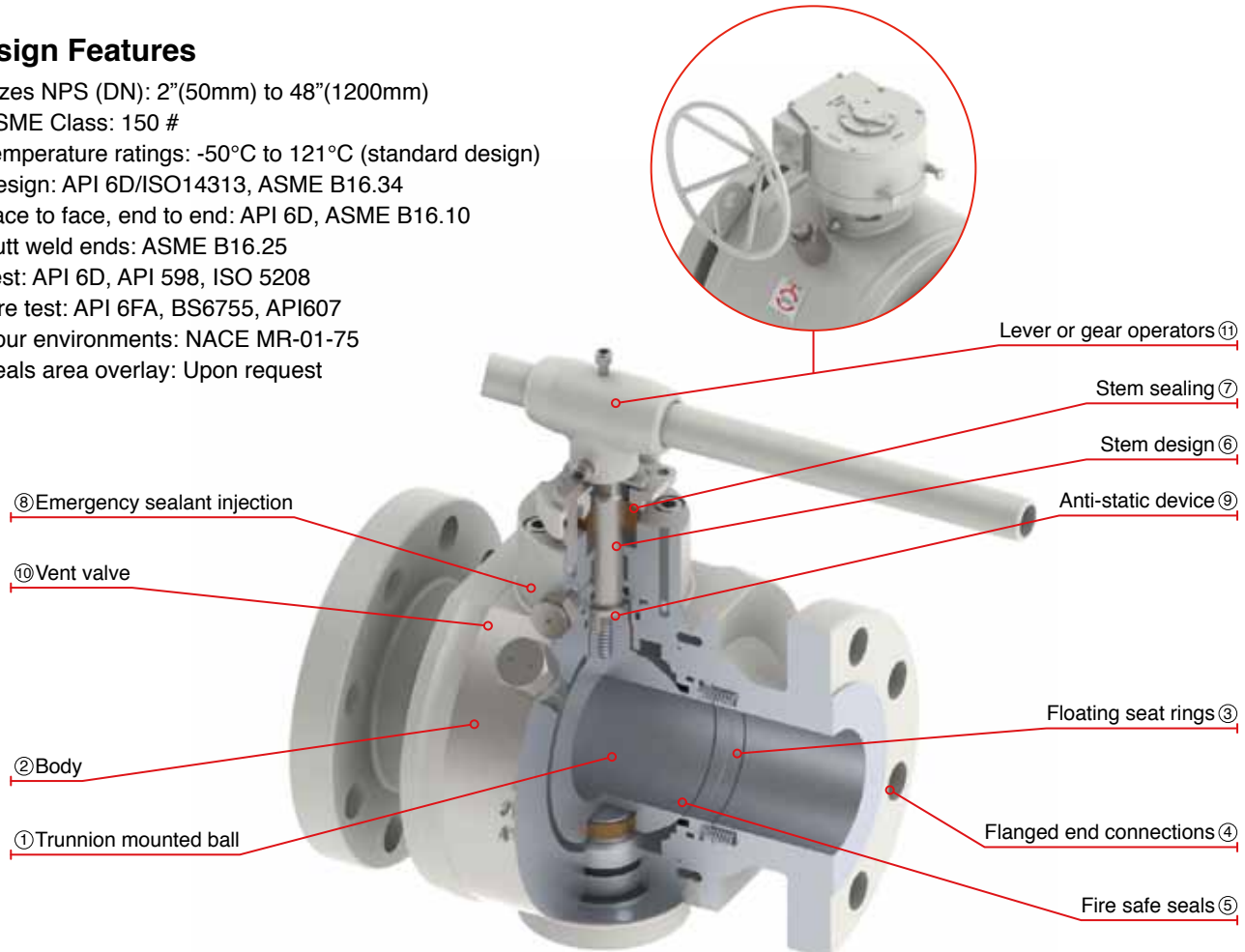

- ① Trunnion mounted ball: For all sizes & pressure ratings. The ball is fixed by an upper & lower trunnion, seat rings are dynamic which will move freely along the horizontal axis.
- ② Welded Body. Engineered and manufactured particularly for heavy-duty services, such feature allows maximum strength it also saves material which makes it lighter than the flanged model its compact design eliminates body flanges weight reducing the possibility of any leakage.
- ③ Floating seat rings. Two independent dynamic seat rings attain Bi-Directional closure of the valve these Seat. Rings are spring loaded that achieve tight shut-off at considerable low differential pressure.
- ④ Flanged ends connections. Forged steel RF or RTJ connections according to ASME B16.5 up to 24” and ASME B16.47 Series A for 26” & larger.
- ⑤ Fire safe seals: Fire safe design prevents leakage when the elastomeric seals are exposed to very high temperatures.
- ⑥ Stem design: Bottom entry anti blow out stem is made of one piece which is held up by the valve body. It has been design to avoid any possible projection due to hazardous conditions.
- ⑦ Stem sealing: Accurate machining process together with electro less nickel plated (ENP) coating control the hardness amongst stem, metallic components & double O’rings, these are supported by a secondary graphite seal which ensure reliable operation at high levels of sealing integrity when operating the valve.
- ⑧ Seats & stem emergency sealant injection (6” & Larges): Valves are supplied with emergency sealant Injectors located between the double O’ring arrangement of the seat assembly & stem seal area. A highly viscous sealant is injected through these fittings to restore closure integrity.*Whenever the valve lifetime has ended or if any of the seats get damaged, the emergency sealant injection system may temporarily be used to achieve tightness before maintenance takes place.
- ⑨ Antistatic device: An inconel spring is placed between body, ball and stem to prevent static continuity.
- ⑩ Block & bleed: Double block & bleed is achieved with the valve in two positions either fully closed or fully opened.
- ⑪ Lever handle: 6” & larger valves supplied with gear operator.

TRUNNION MOUNTED BALL VALVE WELDED BODY, CLASS 300 (LEVER OPERATED)

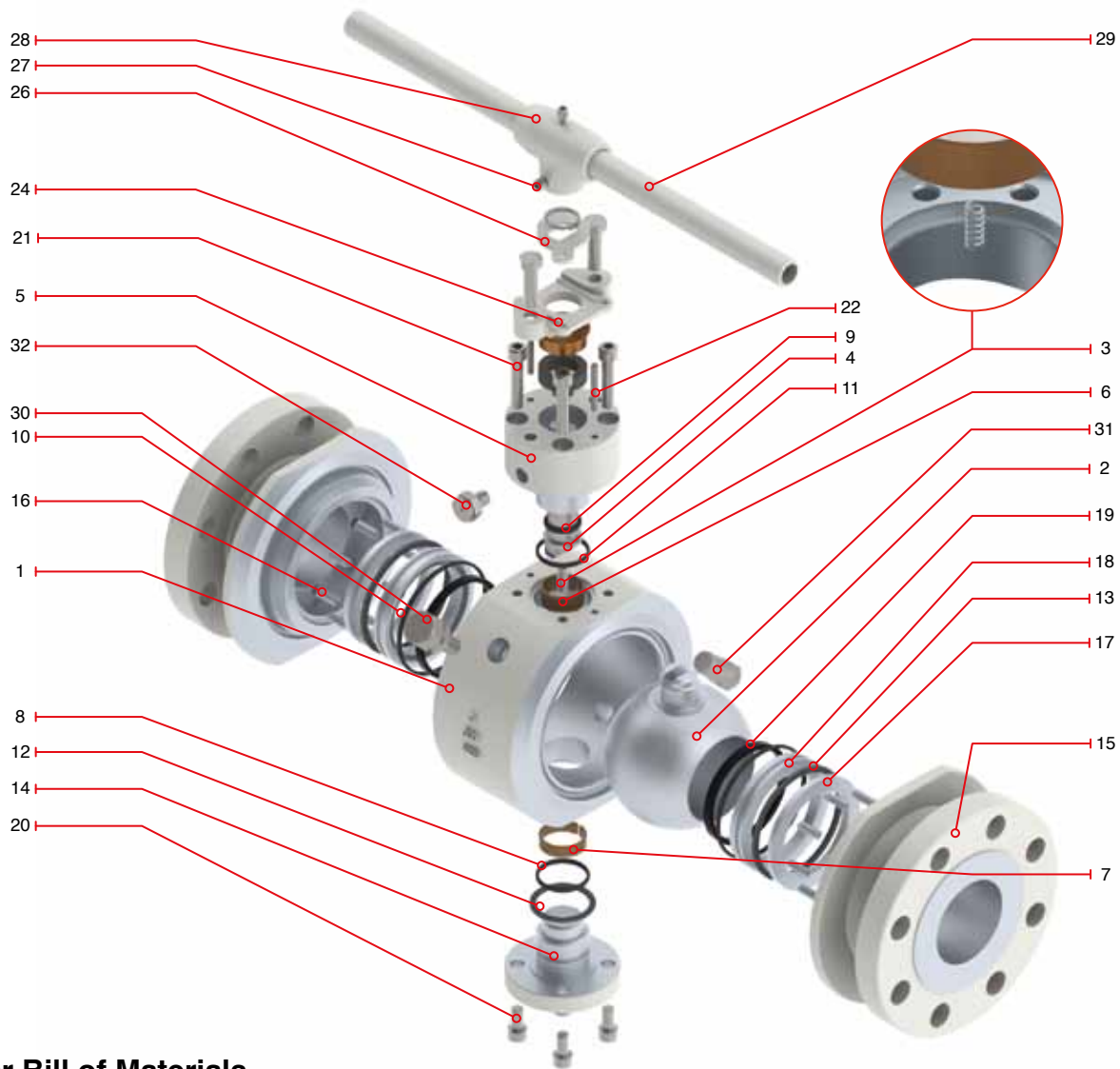

Regular Bill of Materials

No.	Description	ASTM Materials	No.	Description	ASTM Materials
1	Body	ASTM A105N	18	Seat ring	ASTM A105+75µm ENP / AISI 410
2	Ball	ASTM A105+75µm ENP / AISI 410	19	Seat insert	RPTFE
3	Antistatic spring	INCONEL X-750	20	Socket screw	ASTM A193 B7M
4	Stem	AISI 4140+75µm ENP / AISI 410	21	Socket screw	ASTM A193 B7M
5	Trunnion / bonnet	AISI 4140+75µm ENP	22	Pin	Carbon Steel
6	Upper bearing	C.S.+ PTFE LINING	23	Locking device*	A36
7	Lower bearing	C.S.+ PTFE LINING	24	Packing gland flange	ASTM A216 WCB / A105
8	Lower O'ring	Viton	25	Hex. Bolt*	ASTM A193 B7M
9	Upper O'ring	Viton	26	Stop plate	A36
10	Seat O'ring	Viton	27	Retainer	AISI 1070
11	Stem fire safe gasket	Graphite	28	Handle nut	ASTM A216 WCB
12	Trunnion fire safe gasket	Graphite	29	Handle	ASTM A53
13	Seat fire safe gasket	Graphite	30	Vent valve	Carbon Steel
14	Trunnion	AISI 4140+75µm ENP / AISI 410	31	Drain plug	Carbon Steel
15	Flanged ends	A105N	32	Grease fitting*	Carbon Steel
16	Seat spring	INCONEL X-750	33	Lifting lug*	A36
17	Back up seat ring	ASTM A105+75µm ENP / AISI 410	34	Support leg*	A36

* Not shown

TRUNNION MOUNTED BALL VALVE WELDED BODY, CLASS 300 (LEVER OPERATED)

Design Features

- Side entry
- Blow out proof stem
- Soft & metal - metal seats
- Gear operated from 6" and up starting from Class 150 #
- Three piece forged body design
- Bleed valve
- Fire safe packing
- Lifting lugs
- Heavy wall thickness
- Secondary seat injection sealant
- Draining plug



Catalog Figure No.	Type of Ends
8312-W	Raised Face (RF)
8313-W	Ring Type Joint (RTJ)
8314-W	Buttweld (WE)

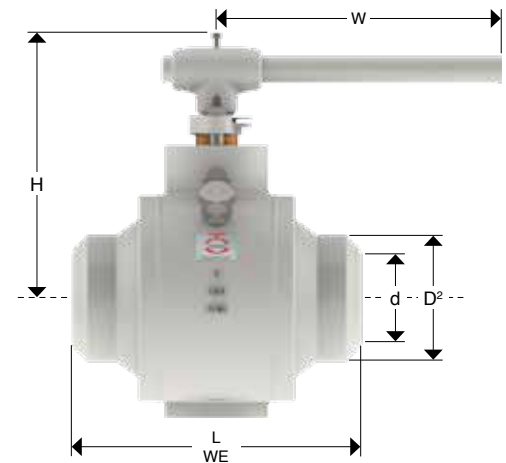
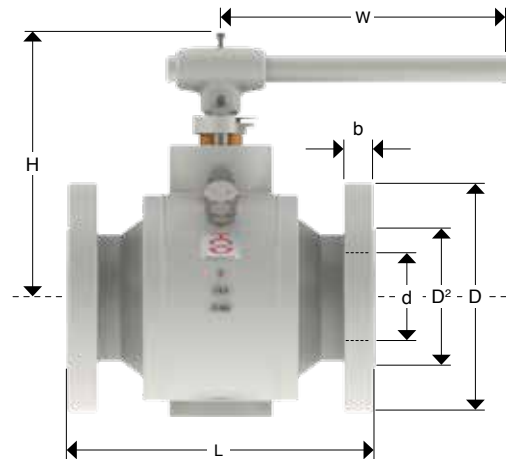

Dimensions and Weights

Nominal Diameter	mm	50	65	80	100
	in	2"	2 ½"	3"	4"
d	mm	49	62	74	100
	in	1.93	2.44	2.91	3.94
D	mm	165	190	210	254
	in	6.50	7.48	8.27	9.02
D2	mm	92	105	127	157
	in	3.62	4.13	5	6.18
b	mm	23	26	29	32
	in	0.63	1.02	1.14	0.94
L	mm	216	241	283	305
	in	8.50	9.49	11.14	9.02
L (WE)	mm	216	241	283	305
	in	8.5	9.48	11,14	12
H	mm	172	210	241	275
	in	6.79	8.28	9.50	10.84
ØW	mm	350	450	500	600
	in	13.78	17.72	19.69	23.62
Weight (RF - RTJ)	kg	22.54	33.32	44.10	74.48
	Lb	49.59	73.30	97.02	163.86

Key Parameters

Code	Name
d	Bore diameter
D	Flange diameter
D2	Raised face diameter
b	Flange thickness
L	Raised face and ring type joint face to face
L (WE)	Welded end face to face
H	Height
ØW	Handwheel diameter
Weight	Weight

TRUNNION MOUNTED BALL VALVE WELDED BODY, CLASS 300 (GEAR OPERATED)

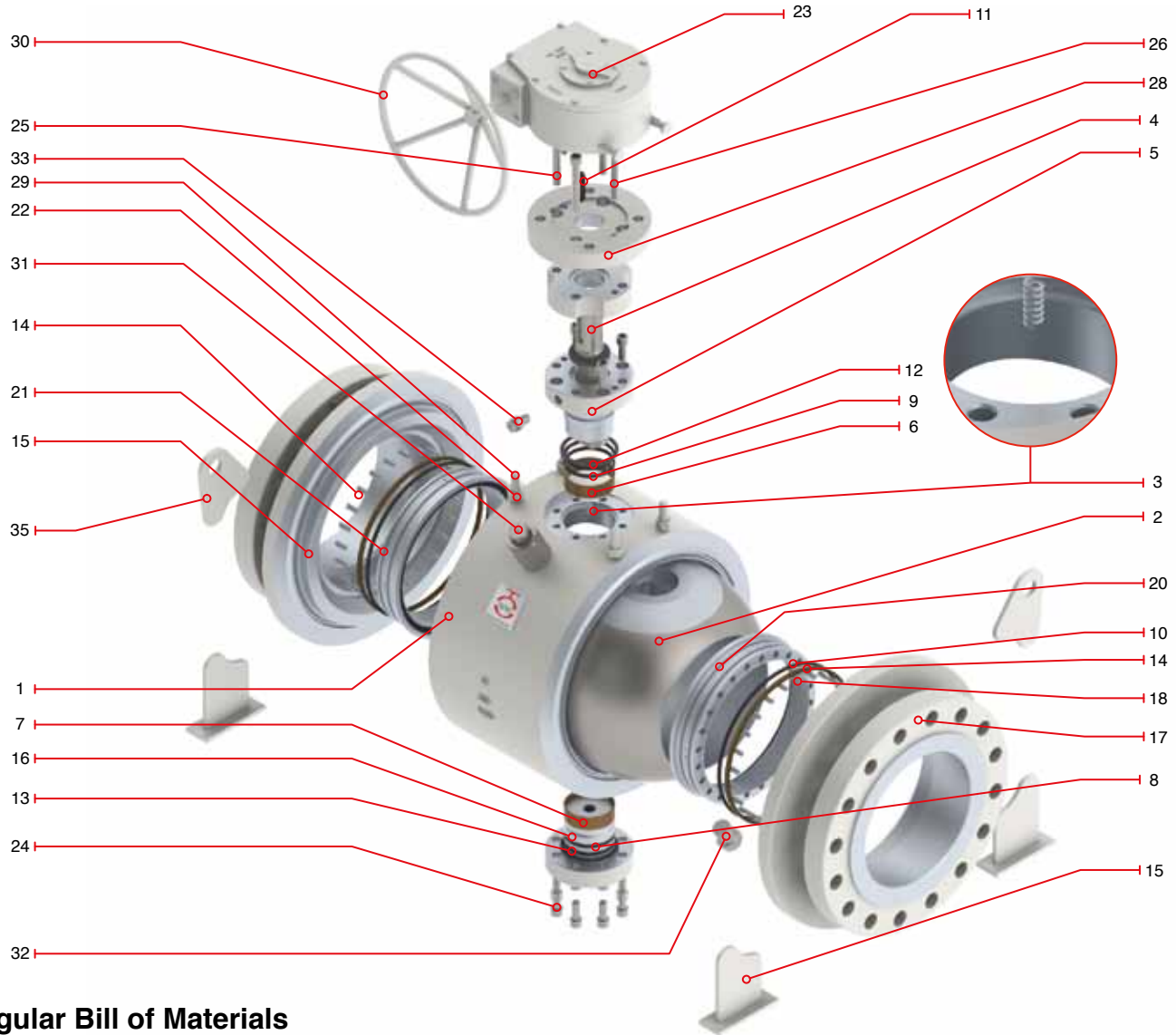

Regular Bill of Materials

No.	Description	ASTM Materials	No.	Description	ASTM Materials
1	Body	ASTM A105N	19	Back up seat ring*	ASTM A105+75µm ENP / AISI 410
2	Ball	ASTM A105+75µm ENP / AISI 410	20	Seat ring	ASTM A105+75µm ENP / AISI 411
3	Antistatic spring	INCONEL X-750	21	Seat insert*	RPTFE
4	Stem	AISI 4140+75µm ENP / AISI 410	22	Spring lock washer	Carbon Steel
5	Trunnion / bonnet	AISI 4140+75µm ENP	23	Gear box	Commercial steel
6	Upper bearing	C.S.+ PTFE LINING	24	Bottom socket screw	ASTM A193 B7M
7	Lower Bearing	C.S.+ PTFE LINING	25	Top socket screw	ASTM A193 B7M
8	Lower O'ring	Viton	26	Pin	ASTM A276 T410
9	Stem O'ring	Viton	27	Packing gland bushing*	AISI 410
10	Seat O'ring	Viton	28	Packing gland flange	ASTM A216 WCB / A105
11	Key	Carbon Steel	29	Hex. Bolt	ASTM A193 B7M
12	Upper fire safe gasket*	Graphite	30	Handwheel	ASTM A53
13	Lower fire safe gasket	Graphite	31	Vent valve	AISI 4140
14	On seat fire safe gasket	Graphite	32	Drain plug	AISI 4140
15	Support leg	A36	33	Stem grease fitting	AISI 4140
16	Lower trunnion	AISI 4140+75µm ENP / AISI 410	34	Ends grease fitting*	AISI 4140
17	Flanged ends	A105N	35	Lifting lug	A36
18	Seat spring	INCONEL X-750			

* Not shown

TRUNNION MOUNTED BALL VALVE WELDED BODY, CLASS 300 (GEAR OPERATED)

Design Features

- Side entry
- Blow out proof stem
- Soft & metal - metal seats
- Gear operated from 6" and up starting from Class 300 #
- Three piece forged body design
- Bleed valve
- Fire safe packing
- Lifting lugs
- Heavy wall thickness
- Secondary seat injection sealant
- Draining plug



Catalog Figure No.	Type of Ends
8322-W	Raised Face (RF)
8323-W	Ring Type Joint (RTJ)
8324-W	Buttweld (WE)

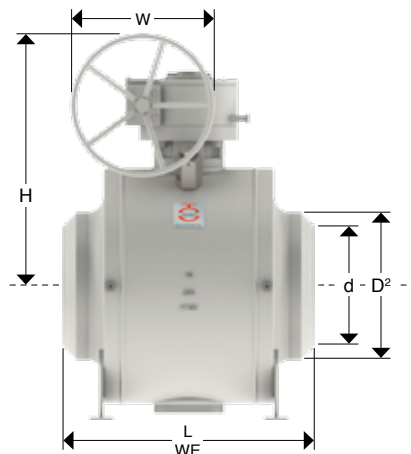
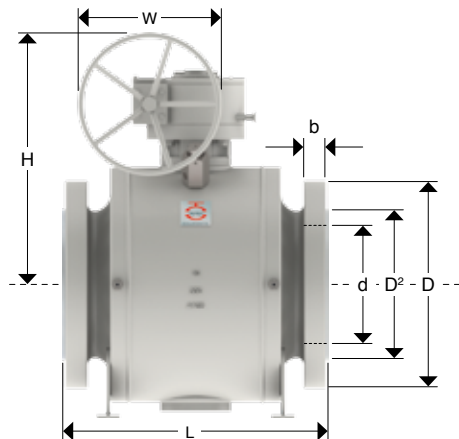

Dimensions and Weights

Nominal Diameter	mm	150	200	250	300	350	400	450	500	610	660	711	762	813	864	914
	in	6"	8"	10"	12"	14"	16"	18"	20"	24"	26"	28"	30"	32"	34"	36"
d	mm	150	201	252	303	334	385	436	487	589	633	684	735	779	830	874
	in	5.91	7.91	9.92	11.93	13.15	15.16	17.17	19.17	23.19	24.92	26.92	28.93	30.66	32.67	34.40
D	mm	318	381	445	521	585	650	710	775	915	970	1035	1090	1150	1205	1270
	in	12.52	15	17.52	20.51	23	25.59	27.95	30.51	36.02	38.18	40.74	42.91	45.27	47.44	50
D2	mm	216	270	324	381	413	470	533	584	692	749	800	857	914	965	1022
	in	8.50	10.63	12.76	15	16.25	18.50	20.98	23	27.24	29.48	31.49	33.74	35.98	37.99	40.23
b	mm	37	42	48	51	52.4	55.6	58.8	62	68.3	77.8	84.2	90.5	96.9	100.1	103.2
	in	1.46	1.65	1.89	2.01	2.13	2.18	2.31	2.44	2.68	3.06	3.31	3.56	3.81	3.94	4.06
L	mm	403	502	568	648	762	838	914	991	1143	1245	1346	1397	1524	1626	1727
	in	15.86	19.76	22.36	25.51	30	33	35.98	39	45	49	53	55	60	64	68
L (WE)	mm	403	521	559	635	762	838	914	991	1143	1245	1346	1397	1524	1626	1727
	in	15.86	20.51	22	25	30	33	35.98	39	45	49	53	55	60	64	68
H	mm	590	657	824	856	770	937	1010	1090	1180	937	937	937	937	937	937
	in	23.23	25.9	32.44	33.7	30.31	36.89	39.77	42.92	46.46	36.89	36.89	36.89	36.89	36.89	36.89
ØW	mm	600	600	800	800	800	800	800	800	800	800	800	800	800	800	800
	in	23.62	23.62	31.50	31.50	31.50	31.50	31.50	31.50	31.50	31.50	31.50	31.50	31.50	31.50	31.50
Weight	kg	181.30	313.60	499.80	715.40	1107.40	1460.20	1871.80	2293.20	3351.60	4253.20	4860.80	5840.80	6624.80	8114.40	9447.20
(RF - RTJ)	Lb	398.86	689.92	1099.56	1573.88	2436.28	3212.44	4117.96	5045.04	7373.52	9357.04	10693.76	12849.76	14574.56	17851.68	20783.84

TRUNNION MOUNTED BALL VALVE WELDED BODY, CLASS 600

Trunnion mounted ball valves are designed and manufactured in conformance with the specification of API 6D, ISO 14313, ASME B16.34, API 6FA, API 607 & NACE MR01-75.

Design Features

- Sizes NPS (DN): 2”(50mm) to 48”(1200mm)
- ASME class: 600 #
- Temperature Ratings: -29°C to 121°C (Standard)
- Design: API 6D/ISO14313, ASME B16.34
- Face to face, end to end: API 6D, ASME B16.10
- Butt weld ends: ASME B16.25
- Test: API 6D, API 598, ISO 5208
- Fire test: API 6FA, BS6755, API607
- Sour environments: NACE MR-01-75
- Seals area overlay: On request

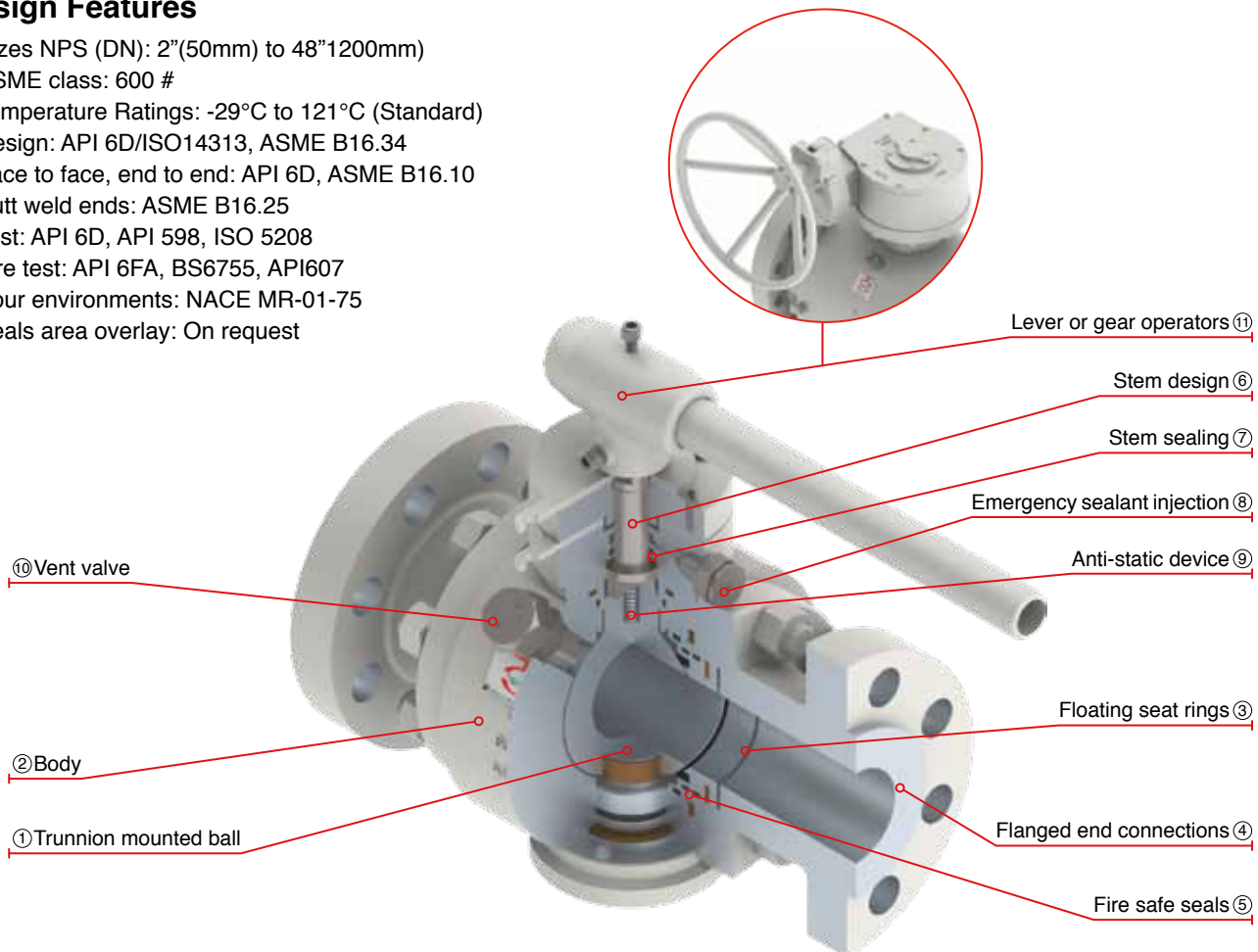

- ① Trunnion mounted ball: For all sizes & pressure ratings. The ball is fixed by an upper & lower trunnion, seat rings are dynamic which will move freely along the horizontal axis.
- ② Body. Three piece forged steel body for easy disassembly on site. Small cavities between body, seats & ball minimize the quantity of fluid that could get stored in that hollow space.
- ③ Floating seat rings. Two independent dynamic seat rings attain Bi-Directional closure of the valve these Seat. Rings are spring loaded that achieve tight shut-off at considerable low differential pressure.
- ④ Flanged ends connections. Forged steel RF or RTJ connections according to ASME B16.5 up to 24” and ASME B16.47 Series A for 26” & larger.
- ⑤ Fire safe seals: Fire safe design prevents leakage when the elastomeric seals are exposed to very high temperatures.
- ⑥ Stem design: Bottom entry anti blow out stem is made of one piece which is held up by the valve body. It has been design to avoid any possible projection due to hazardous conditions.
- ⑦ Stem sealing: Accurate machining process together with electro less nickel plated (ENP) double explosive decompression resistant (EDR) O’rings, these are supported by a secondary graphite seal which ensure reliable operation at high levels of sealing integrity when operating the valve.
- ⑧ Seats & stem emergency sealant injection (4” & larger): Valves are supplied with emergency sealant Injectors located between the double O’ring arrangement of the seat assembly & stem seal area. A highly viscous sealant is injected through these fittings to restore closure integrity.*Whenever the valve lifetime has ended or if any of the seats get damaged, the emergency sealant injection system may temporarily be used to achieve tightness before maintenance takes place.
- ⑨ Antistatic device: An inconel spring is placed between body, ball and stem to prevent static continuity.
- ⑩ Block & bleed: Double block & bleed is achieved with the valve in two positions either fully closed or fully opened.
- ⑪ Lever handle: 6” & larger valves supplied with gear operator.

TRUNNION MOUNTED BALL VALVE WELDED BODY, CLASS 600 (LEVER OPERATED)

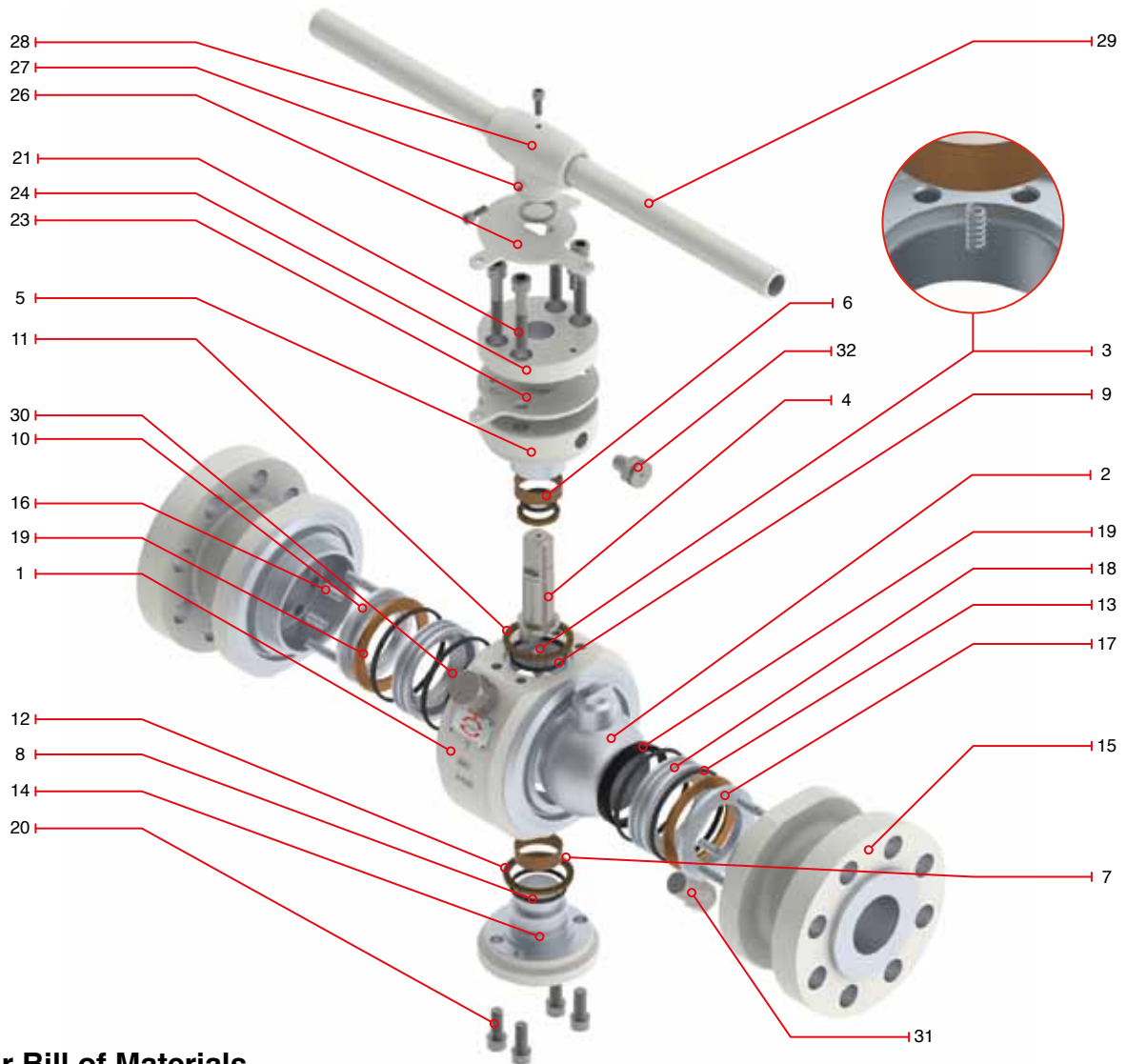

Regular Bill of Materials

No.	Description	ASTM Materials	No.	Description	ASTM Materials
1	Body	ASTM A105N	18	Seat ring	ASTM A105+75µm ENP / AISI 410
2	Ball	ASTM A105+75µm ENP / AISI 410	19	Seat insert	RPTFE
3	Antistatic spring	INCONEL X-750	20	Socket screw	ASTM A193 B7M
4	Stem	AISI 4140+75µm ENP / AISI 410	21	Socket screw	ASTM A193 B7M
5	Trunnion / bonnet	AISI 4140+75µm ENP	22	Pin*	Carbon Steel
6	Upper bearing	C.S.+ PTFE LINING	23	Locking device	A36
7	Lower bearing	C.S.+ PTFE LINING	24	Packing gland flange	ASTM A216 WCB / A105
8	Lower O'ring	Viton	25	Hex. Bolt*	ASTM A193 B7M
9	Upper O'ring	Viton	26	Stop plate	A36
10	Seat O'ring	Viton	27	Retainer	AISI 1070
11	Stem fire safe gasket	Graphite	28	Handle nut	ASTM A216 WCB
12	Trunnion fire safe gasket	Graphite	29	Handle	ASTM A53
13	Seat fire safe gasket	Graphite	30	Vent valve	Carbon Steel
14	Trunnion	AISI 4140+75µm ENP / AISI 410	31	Drain plug	Carbon Steel
15	Flanged ends	A105N	32	Grease fitting	Carbon Steel
16	Seat spring	INCONEL X-750	33	Lifting lug*	A36
17	Back up seat ring	ASTM A105+75µm ENP / AISI 410	34	Support leg*	A36

* Not shown

TRUNNION MOUNTED BALL VALVE WELDED BODY, CLASS 600 (LEVER OPERATED)

Design Features

- Side entry
- Blow out proof stem
- Soft & metal - metal seats
- Gear operated from 6" and up starting from Class 600 #
- Three piece forged body design
- Bleed valve
- Fire safe packing
- Lifting lugs
- Heavy wall thickness
- Secondary seat injection sealant
- Draining plug



Catalog Figure No.	Type of Ends
8612-W	Raised Face (RF)
8613-W	Ring Type Joint (RTJ)
8614-W	Buttweld (WE)

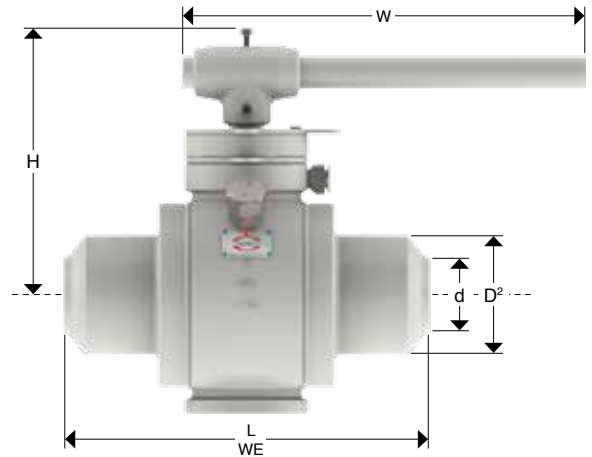
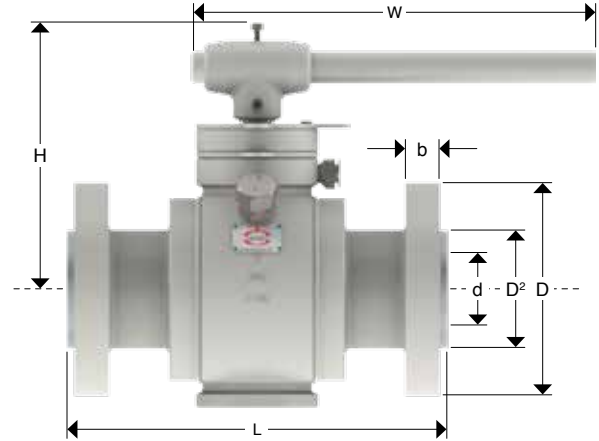

Dimensions and Weights

Nominal Diameter	mm	50	65	80	100
	in	2"	2 ½"	3"	4"
d	mm	49	62	74	100
	in	1.93	2.44	2.91	3.94
D	mm	165	190	210	275
	in	6.50	7.48	8.27	10.75
D2	mm	92	105	127	157
	in	3.62	4.13	5	6.18
b	mm	26	29	32	38
	in	1.02	1.14	1.26	1.50
L	mm	292	330	356	432
	in	11.50	13	14.02	17.01
L (WE)	mm	292	330	356	432
	in	11.50	13	14.02	17.01
H	mm	203	220	220	255
	in	8.01	8.68	8.68	10.06
ØW	mm	500	600	700	800
	in	19.69	23.62	27.56	31.50
Weight (RF - RTJ)	kg	33.32	50.07	65.79	147.31
	Lb	73.30	110.15	144.75	324.08

Key Parameters

Code	Name
d	Bore diameter
D	Flange diameter
D2	Raised face diameter
b	Flange thickness
L	Raised face and ring type joint face to face
L (WE)	Welded end face to face
H	Height
ØW	Handwheel diameter
Weight	Weight

TRUNNION MOUNTED BALL VALVE WELDED BODY, CLASS 600 (GEAR OPERATED)

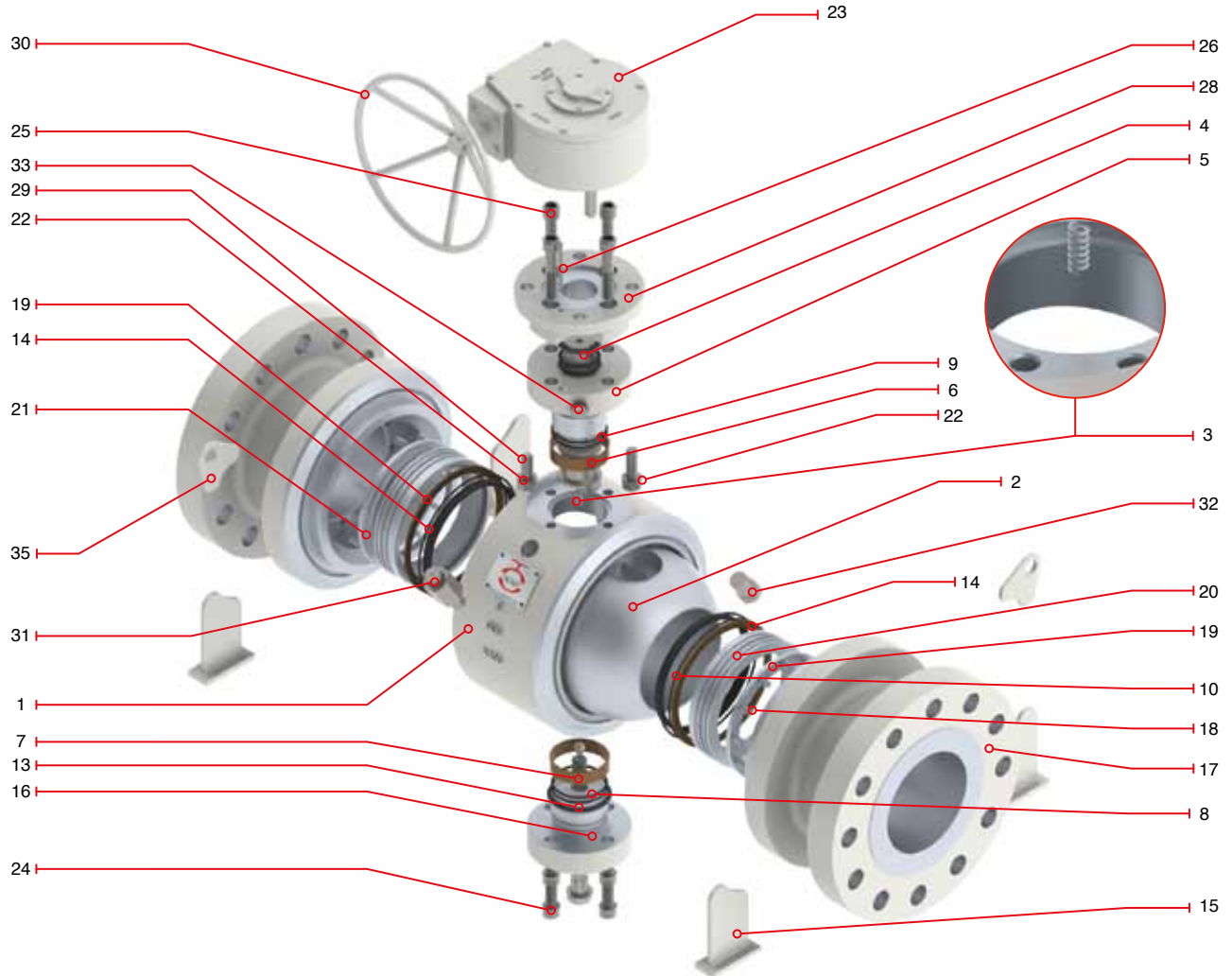

Regular Bill of Materials

No.	Description	ASTM Materials	No.	Description	ASTM Materials
1	Body	ASTM A105N	19	Back up seat ring	ASTM A105+75µm ENP / AISI 410
2	Ball	ASTM A105+75µm ENP / AISI 410	20	Seat ring	ASTM A105+75µm ENP / AISI 411
3	Antistatic spring	INCONEL X-750	21	Seat insert	RPTFE
4	Stem	AISI 4140+75µm ENP / AISI 410	22	Spring lock washer	Carbon Steel
5	Trunnion / bonnet	AISI 4140+75µm ENP	23	Gear box	Commercial steel
6	Upper bearing	C.S.+ PTFE LINING	24	Bottom socket screw	ASTM A193 B7M
7	Lower Bearing	C.S.+ PTFE LINING	25	Top socket screw	ASTM A193 B7M
8	Lower O'ring	Viton	26	Pin	ASTM A276 T410
9	Stem O'ring*	Viton	27	Packing gland bushing*	AISI 410
10	Seat O'ring	Viton	28	Packing gland flange	ASTM A216 WCB / A105
11	Key*	Carbon Steel	29	Hex. Bolt	ASTM A193 B7M
12	Upper fire safe gasket*	Graphite	30	Handwheel	ASTM A53
13	Lower fire safe gasket	Graphite	31	Vent valve	AISI 4140
14	On seat fire safe gasket	Graphite	32	Drain plug	AISI 4140
15	Support leg	A36	33	Stem grease fitting	AISI 4140
16	Lower trunnion	AISI 4140+75µm ENP / AISI 410	34	Ends grease fitting*	AISI 4140
17	Flanged ends	A105N	35	Lifting lug	A36
18	Seat spring	INCONEL X-750			

* Not shown

TRUNNION MOUNTED BALL VALVE WELDED BODY, CLASS 600 (GEAR OPERATED)

Design Features

- Side entry
- Blow out proof stem
- Soft & metal - metal seats
- Gear operated from 6" and up starting from Class 600 #
- Three piece forged body design
- Bleed valve
- Fire safe packing
- Lifting lugs
- Heavy wall thickness
- Secondary seat injection sealant
- Draining plug



Catalog Figure No.	Type of Ends
8622-W	Raised Face (RF)
8623-W	Ring Type Joint (RTJ)
8624-W	Buttweld (WE)

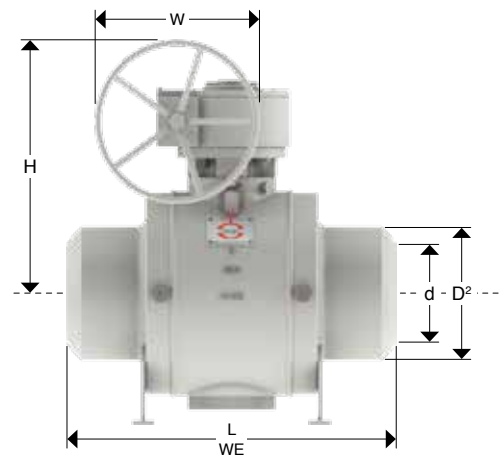
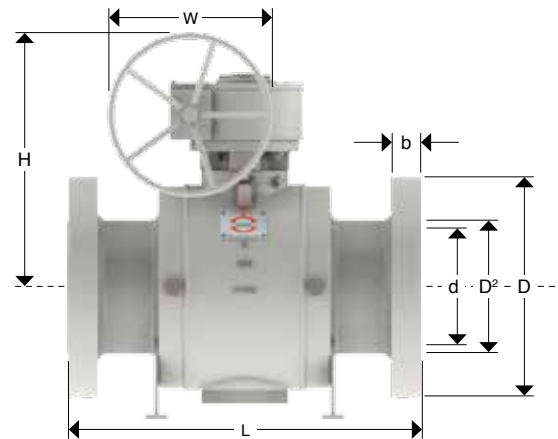

Dimensions and Weights

Nominal Diameter	mm	150	200	250	300	350	400	450	500	610	660	711	762	813	864	914
	in	6"	8"	10"	12"	14"	16"	18"	20"	24"	26"	28"	30"	32"	34"	36"
d	mm	150	201	252	303	334	385	436	487	589	633	684	735	779	830	874
	in	5.91	7.91	9.92	11.93	13.15	15.16	17.17	19.17	23.19	24.92	26.92	28.93	30.66	32.67	34.40
D	mm	355	420	510	560	605	685	745	815	940	1015	1075	1130	1195	1245	1315
	in	14.02	16.50	20	22.01	23.81	26.96	29.33	32.08	37	40	42.32	44.48	47.04	49.01	51.71
D2	mm	216	270	324	381	413	470	533	584	692	749	800	857	914	965	1022
	in	8.50	10.63	12.76	15	16.26	18.50	20.98	23	27.24	29.48	31.49	33.74	35.98	37.99	40.23
b	mm	48	56	64	67	70	76,2	83	89	102	108	111	114	117	121	124
	in	1.89	2.20	2.52	2.64	2.76	3	3.25	3.5	4.02	4.02	4.37	4.48	4.60	4.76	4.88
L	mm	559	660	787	838	889	991	1092	1194	1397	1448	1549	1651	1778	1930	2083
	in	22.01	25.98	30.98	33	35	39.02	43	47.01	55	57	60.98	65	70	75.98	82
L (WE)	mm	559	660	787	838	889	991	1092	1194	1397	1448	1549	1651	1778	1930	2083
	in	22.01	25.98	30.98	33	35	39.02	43	47.01	55	57	60.98	65	70	75.98	82
H	mm	510	580	750	790	790	833	879	919	1020	1058	1118	1153	1206	1248	1294
	in	20.07	22.83	29.53	31.1	31.1	32.79	34.6	36.18	40.15	41.65	44.01	45.39	47.48	49.13	50.94
ØW	mm	400	400	600	600	800	800	800	800	800	800	800	800	800	800	800
	in	15.75	15.75	23.62	23.62	31.50	31.50	31.50	31.50	31.50	31.50	31.50	31.50	31.50	31.50	31.50
Weight	kg	314.25	500.85	795.58	1041.03	1325.67	1905.21	2465.15	3191.68	4851.45	5725.43	6579.36	7316.15	8317.97	10173.74	11862.90
	Lb	691.36	1101.86	1750.28	2290.26	2916.48	4191.46	5423.32	7021.70	10673.18	12595.94	14474.60	16095.52	18299.54	22382.22	26098.38

TRUNNION MOUNTED BALL VALVE WELDED BODY, CLASS 900

Trunnion Mounted Ball Valves are designed and manufactured in conformance with API 6D, ISO 14313, ASME B16.34, API 6FA, API 607 & NACE MR01-75.

Design Features

- Sizes NPS (DN): 2”(50mm) to 48”(1200mm)
- ASME class: 900 #
- Temperature Ratings: -29°C to 121°C (Standard)
- Design: API 6D/ISO14313, ASME B16.34
- Face to face, end to end: API 6D, ASME B16.10
- Butt weld ends: ASME B16.25
- Test: API 6D, API 598, ISO 5208
- Fire test: API 6FA, BS6755, API607
- Sour environments: NACE MR-01-75
- Seals area overlay: On request

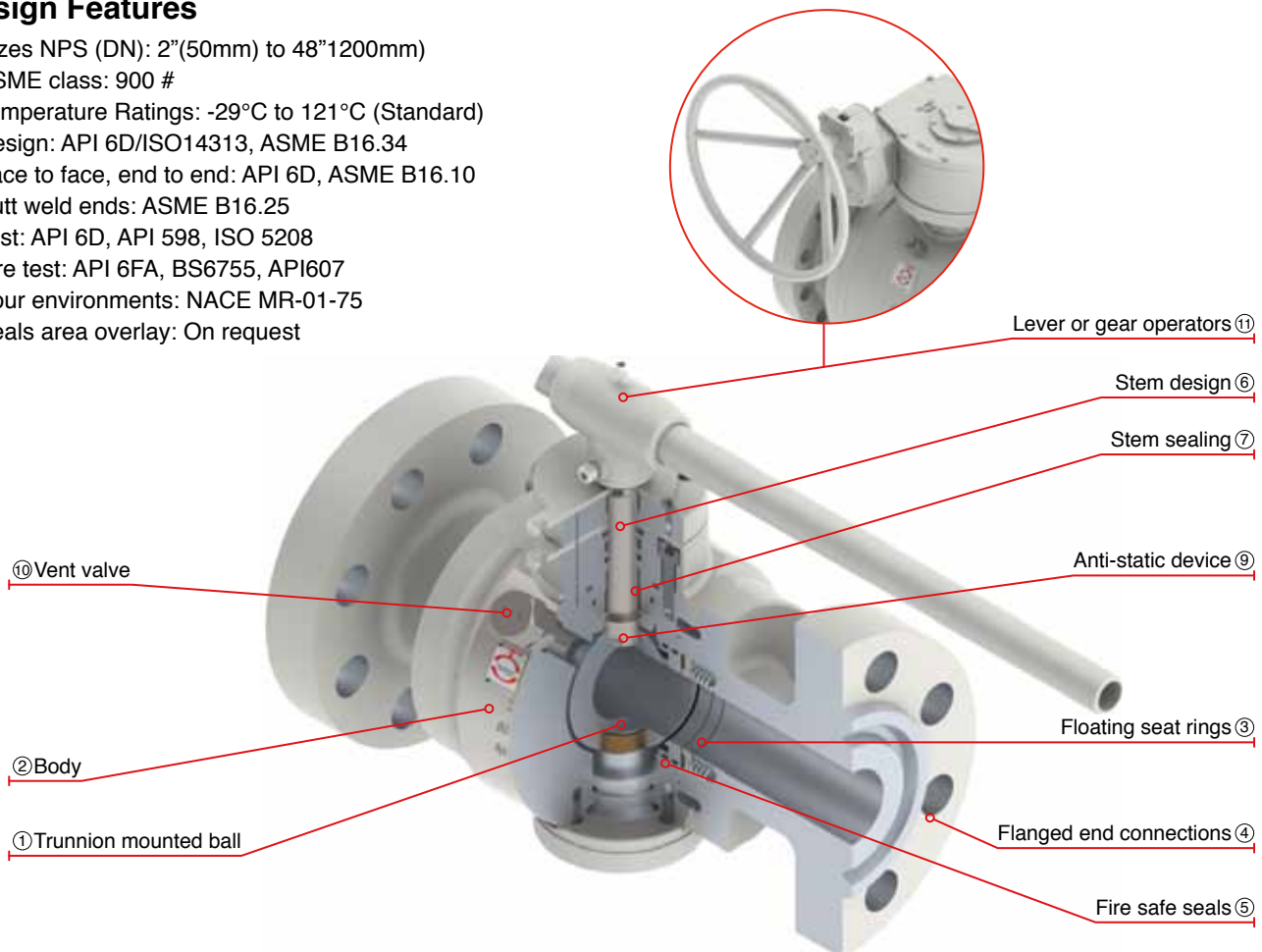

- ① Trunnion mounted ball: For all sizes & pressure ratings. The ball is fixed by an upper & lower trunnion, seat rings are dynamic which will move freely along the horizontal axis.
- ② Body. Three piece forged steel body for easy disassembly on site. Small cavities between body, seats & ball minimize the quantity of fluid that could get stored in that hollow space.
- ③ Floating seat rings. Two independent dynamic seat rings attain Bi-Directional closure of the valve these Seat. Rings are spring loaded that achieve tight shut-off at considerable low differential pressure.
- ④ Flanged ends connections. Forged steel RF or RTJ connections according to ASME B16.5 up to 24” and ASME B16.47 Series A for 26” & larger.
- ⑤ Fire safe seals: Fire safe design prevents leakage when the elastomeric seals are exposed to very high temperatures.
- ⑥ Stem design: Bottom entry anti blow out stem is made of one piece which is held up by the valve body. It has been design to avoid any possible projection due to hazardous conditions.
- ⑦ Stem sealing: Accurate machining process together with electro less nickel plated (ENP) double explosive decompression resistant (EDR) O’rings, these are supported by a secondary graphite seal which ensure reliable operation at high levels of sealing integrity when operating the valve.
- ⑧ Seats & stem emergency sealant injection (4” & larger): Valves are supplied with emergency sealant Injectors located between the double O’ring arrangement of the seat assembly & stem seal area. A highly viscous sealant is injected through these fittings to restore closure integrity.*Whenever the valve lifetime has ended or if any of the seats get damaged, the emergency sealant injection system may temporarily be used to achieve tightness before maintenance takes place.
- ⑨ Antistatic device: An inconel spring is placed between body, ball and stem to prevent static continuity.
- ⑩ Block & bleed: Double block & bleed is achieved with the valve in two positions either fully closed or fully opened.
- ⑪ Lever handle: 6” & larger valves supplied with gear operator.

TRUNNION MOUNTED BALL VALVE WELDED BODY, CLASS 900 (LEVER OPERATED)

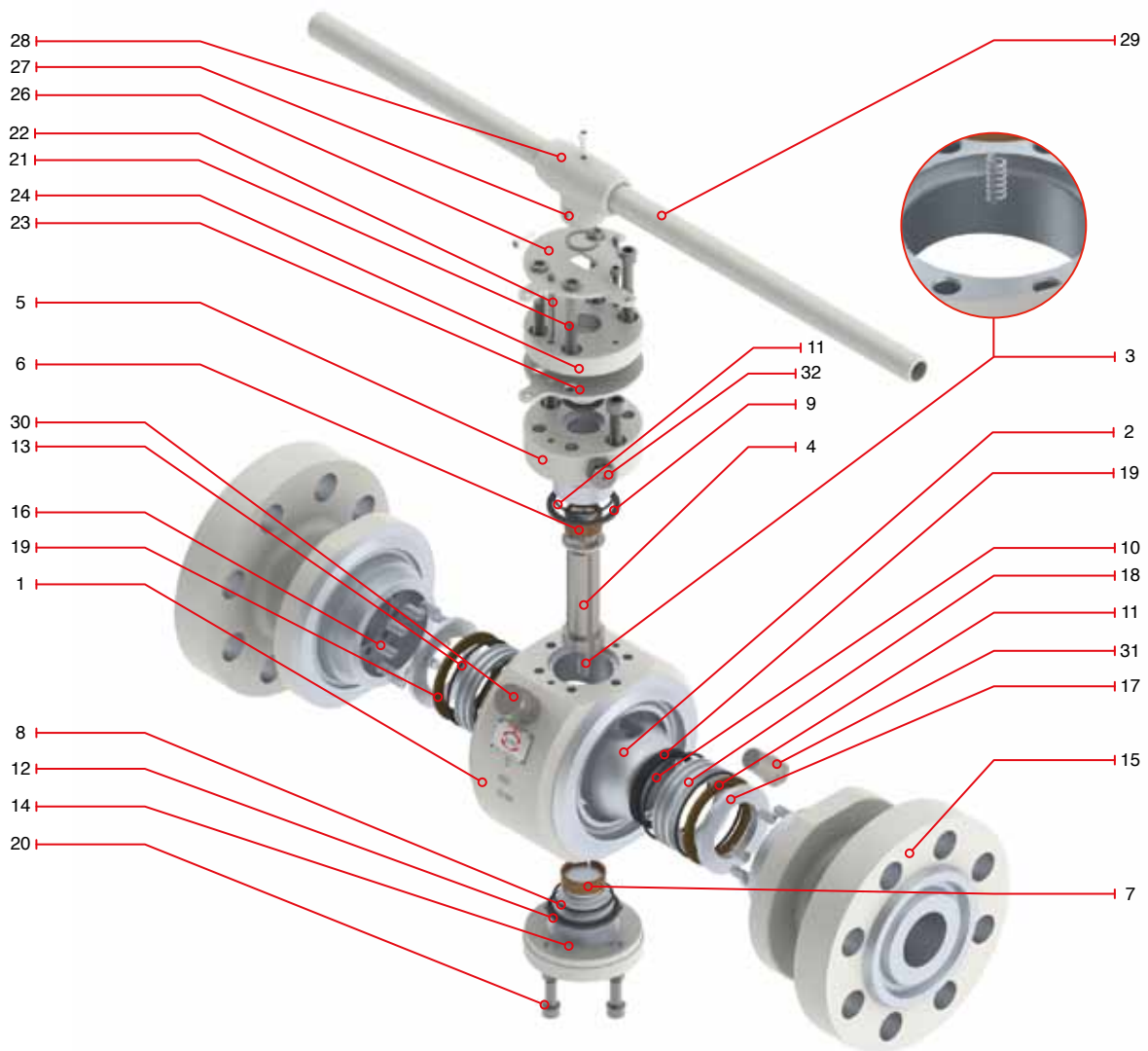

Regular Bill of Materials

No.	Description	ASTM Materials	No.	Description	ASTM Materials
1	Body	ASTM A105N	18	Seat ring	ASTM A105+75µm ENP / AISI 410
2	Ball	ASTM A105+75µm ENP / AISI 410	19	Seat insert	RPTFE
3	Antistatic spring	INCONEL X-750	20	Socket screw	ASTM A193 B7M
4	Stem	AISI 4140+75µm ENP / AISI 410	21	Socket screw	ASTM A193 B7M
5	Trunnion / bonnet	AISI 4140+75µm ENP	22	Pin	Carbon Steel
6	Upper bearing	C.S. + PTFE LINING	23	Locking device	A36
7	Lower bearing	C.S. + PTFE LINING	24	Packing gland flange	ASTM A216 WCB / A105
8	Lower O'ring	Viton	25	Hex. Bolt*	ASTM A193 B7M
9	Upper O'ring	Viton	26	Stop plate	A36
10	Seat O'ring	Viton	27	Retainer	AISI 1070
11	Stem fire safe gasket	Graphite	28	Handle nut	ASTM A216 WCB
12	Trunnion fire safe gasket	Graphite	29	Handle	ASTM A53
13	Seat fire safe gasket	Graphite	30	Vent valve	Carbon Steel
14	Trunnion	AISI 4140+75µm ENP / AISI 410	31	Drain plug	Carbon Steel
15	Flanged ends	A105N	32	Grease fitting	Carbon Steel
16	Seat spring	INCONEL X-750	33	Lifting lug*	A36
17	Back up seat ring	ASTM A105+75µm ENP / AISI 410	34	Support leg*	A36

* Not shown

TRUNNION MOUNTED BALL VALVE WELDED BODY, CLASS 900 (LEVER OPERATED)

Design Features

- Side entry
- Blow out proof stem
- Soft & metal - metal seats
- Gear operated from 6" and up starting from Class 900 #
- Three piece forged body design
- Bleed valve
- Fire safe packing
- Lifting lugs
- Heavy wall thickness
- Secondary seat injection sealant
- Draining plug



Catalog Figure No.	Type of Ends
8912-W	Raised Face (RF)
8913-W	Ring Type Joint (RTJ)
8914-W	Buttweld (WE)

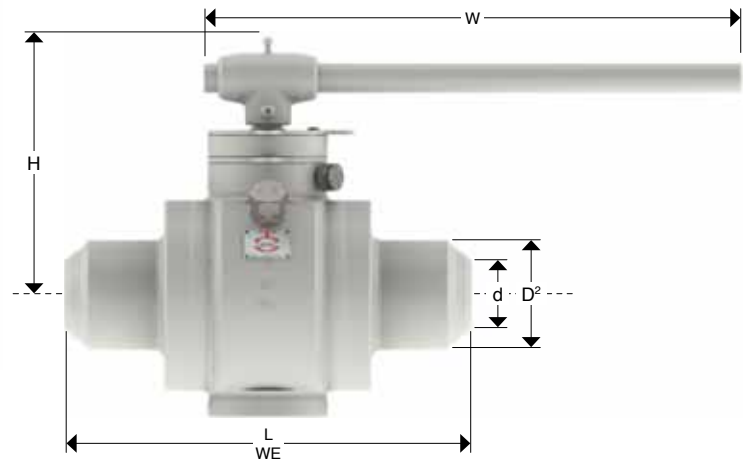
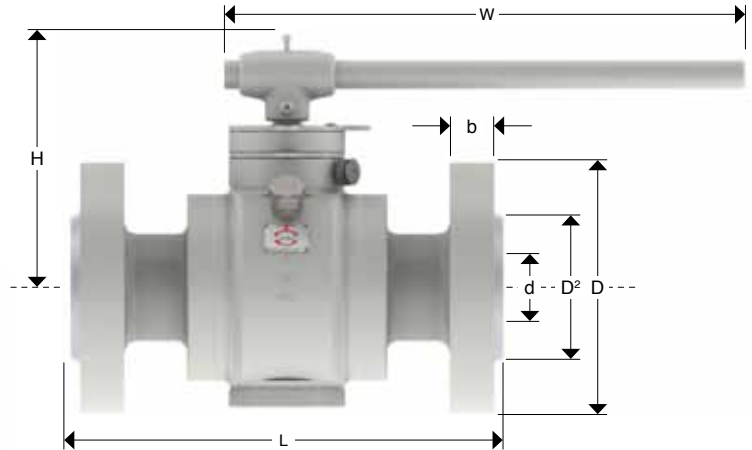

Dimensions and Weights

Nominal Diameter	mm	50	65	80	100
	in	2"	2 1/2"	3"	4"
d	mm	49	62	74	100
	in	1.93	2.44	2.91	3.94
D	mm	216	244	241	292
	in	8.50	9.61	8.27	11.50
D2	mm	92	105	127	157
	in	3.62	4.13	5	6.18
b	mm	38.5	41.5	38.5	44.5
	in	1.52	1.63	1.26	1.75
L	mm	368	419	381	457
	in	14.50	16.50	14.02	18
L (WE)	mm	368	419	381	457
	in	14.50	16.50	14.02	18
H	mm	213	220	220	275
	in	8.37	8.68	8.68	10.84
ØW	mm	700	800	800	POA
	in	27.56	23.62	27.56	
Weight (RF - RTJ)	kg	56.13	73.50	81.52	143.44
	Lb	123.48	161.70	179.34	315.56

Key Parameters

Code	Name
d	Bore diameter
D	Flange diameter
D2	Raised face diameter
b	Flange thickness
L	Raised face and ring type joint face to face
L (WE)	Welded end face to face
H	Height
ØW	Handwheel diameter
Weight	Weight

TRUNNION MOUNTED BALL VALVE WELDED BODY, CLASS 900 (GEAR OPERATED)

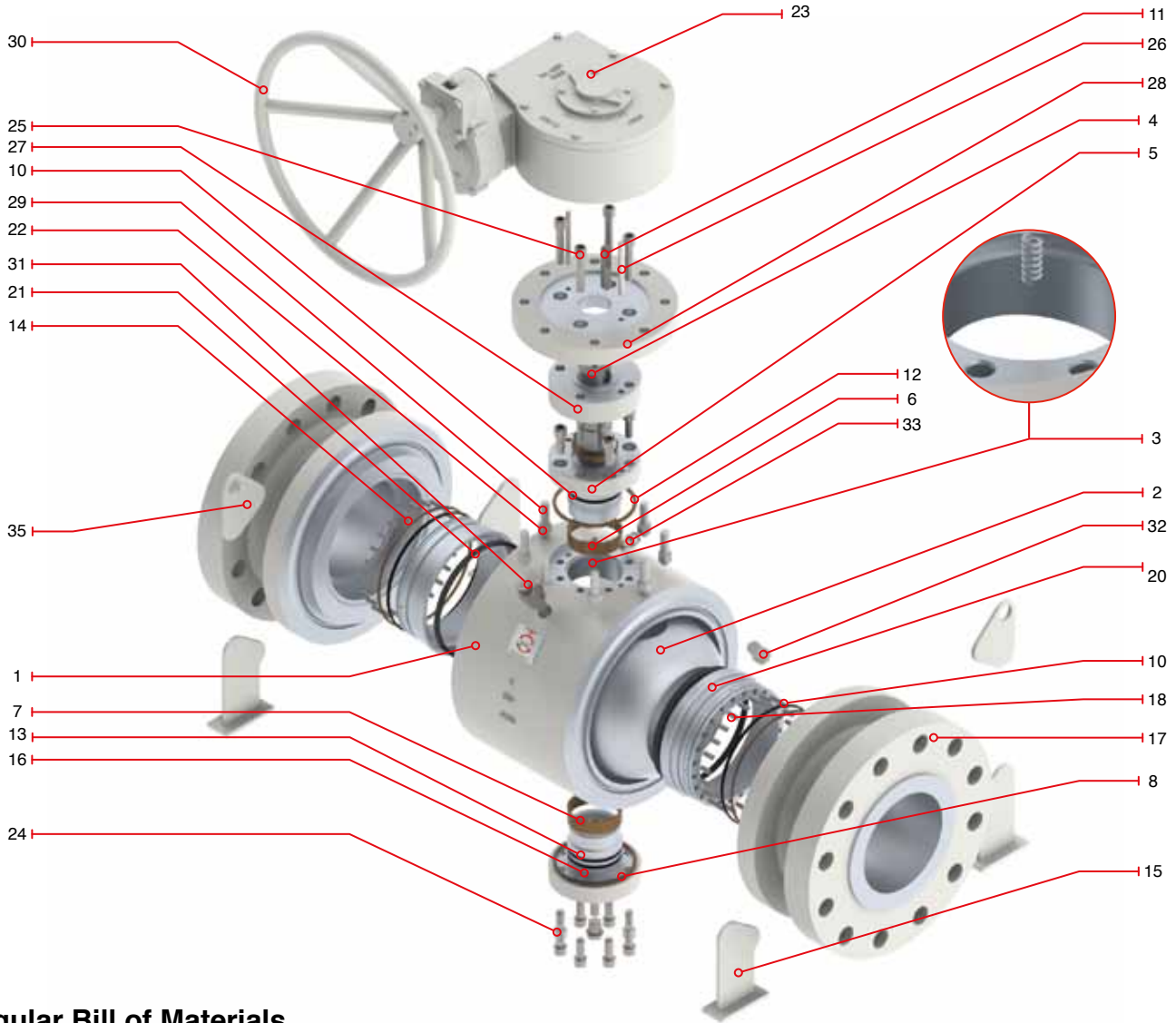

Regular Bill of Materials

No.	Description	ASTM Materials	No.	Description	ASTM Materials
1	Body	ASTM A105N	19	Back up seat ring*	ASTM A105+75µm ENP / AISI 410
2	Ball	ASTM A105+75µm ENP / AISI 410	20	Seat ring	ASTM A105+75µm ENP / AISI 411
3	Antistatic spring	INCONEL X-750	21	Seat insert	RPTFE
4	Stem	AISI 4140+75µm ENP / AISI 410	22	Spring lock washer	Carbon Steel
5	Trunnion / bonnet	AISI 4140+75µm ENP	23	Gear box	Commercial steel
6	Upper bearing	C.S.+ PTFE LINING	24	Bottom socket screw	ASTM A193 B7M
7	Lower Bearing	C.S.+ PTFE LINING	25	Top socket screw	ASTM A193 B7M
8	Lower O'ring	Viton	26	Pin	ASTM A276 T410
9	Stem O'ring*	Viton	27	Packing gland bushing*	AISI 410
10	Seat O'ring	Viton	28	Packing gland flange	ASTM A216 WCB / A105
11	Key	Carbon Steel	29	Hex. Bolt	ASTM A193 B7M
12	Upper fire safe gasket*	Graphite	30	Handwheel	ASTM A53
13	Lower fire safe gasket	Graphite	31	Vent valve	AISI 4140
14	On seat fire safe gasket	Graphite	32	Drain plug	AISI 4140
15	Support leg	A36	33	Stem grease fitting	AISI 4140
16	Lower trunnion	AISI 4140+75µm ENP / AISI 410	34	Ends grease fitting*	AISI 4140
17	Flanged ends	A105N	35	Lifting lug	A36
18	Seat spring	INCONEL X-750			

* Not shown

TRUNNION MOUNTED BALL VALVE WELDED BODY, CLASS 900 (GEAR OPERATED)

Design Features

- Side entry
- Blow out proof stem
- Soft & metal - metal seats
- Gear operated from 6" and up starting from Class 900 #
- Three piece forged body design
- Bleed valve
- Fire safe packing
- Lifting lugs
- Heavy wall thickness
- Secondary seat injection sealant
- Draining plug



Catalog Figure No.	Type of Ends
8922-W	Raised Face (RF)
8923-W	Ring Type Joint (RTJ)
8924-W	Buttweld (WE)

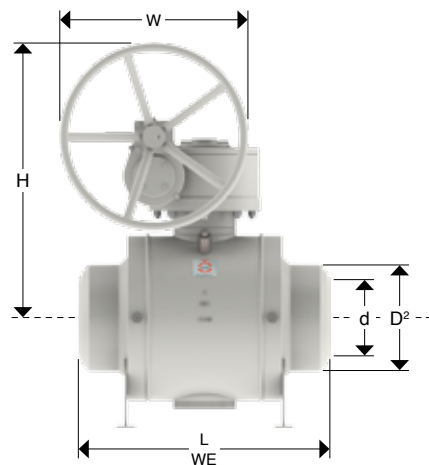
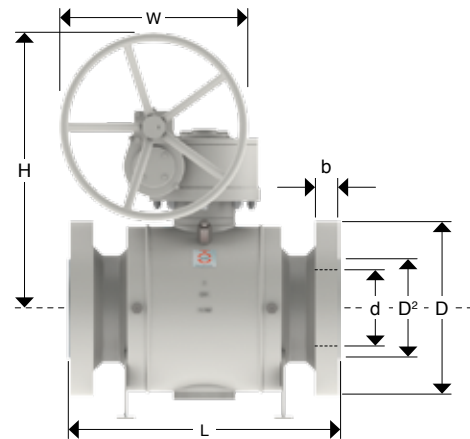

Dimensions and Weights

Nominal Diameter	mm	150	200	250	300	350	400	450	500	610	660	711	762	813	864	914
	in	6"	8"	10"	12"	14"	16"	18"	20"	24"	26"	28"	30"	32"	34"	36"
d	mm	150	201	252	303	322	373	423	471	570	617	665	712	760	808	855
	in	5.91	7.91	9.92	11.93	13.15	14.69	16.65	18.54	22.44	24.29	26.18	28.03	30	32	34
D	mm	381	470	546	610	640	705	785	855	1040	1085	1170	1230	1315	1395	1460
	in	15	18.50	21.50	24.02	25.19	27.76	31	33.66	40.94	42.71	46.06	48.42	51.77	54.92	57.48
D2	mm	216	270	324	419	467	524	594	648	772	832	889	946	1003	1067	1124
	in	8.50	10.63	12.76	15	18.38	20.67	23.38	25.51	30.39	32.75	35	37.24	39.48	42	44.25
b	mm	56	63.5	70	79.5	86	89	102	108	140	140	143	149	159	165	172
	in	2.20	2.50	2.76	3.13	3.39	3.50	3.27	4.25	5.51	5.51	5.62	5.86	6.25	6.5	6.7
L	mm	610	737	838	968	1029	1130	1219	1321	1549	1651	APM	1880	APM	APM	2286
	in	24.02	29.02	33	38	40.51	44.49	43	52.01	60.98	65	APM	74	APM	APM	90
L (WE)	mm	610	737	838	968	1029	1130	1219	1321	1549	APM	APM	APM	APM	APM	APM
	in	24.02	29.02	33	38	40.51	44.49	43	52.01	60.98	APM	APM	APM	APM	APM	APM
H	mm	690	758	824	856	875	937	1020	1080	1295	APM	APM	APM	APM	APM	APM
	in	27.17	29.84	32.44	33.7	34.45	36.89	40.16	42.52	51	APM	APM	APM	APM	APM	APM
ØW	mm	800	800	800	800	800	800	800	800	800	800	800	800	800	800	800
	in	31.50	31.50	31.50	31.50	31.50	31.50	31.50	31.50	31.50	31.50	31.50	31.50	31.50	31.50	31.50
Weight (RF - RTJ)	kg	329.19	608.94	943.03	1257.07	1689.16	2209.90	3014.84	3977.46	5990.47	6943.30	7925.08	9506.45	10802.72	13228.22	15418.52
	Lb	724.22	1339.66	2074.66	2765.56	3716.16	4861.78	6632.64	8750.42	13179.04	15275.26	17435.18	20914.18	23765.98	29102.08	33920.74

APM = As per manufacturer

TRUNNION MOUNTED BALL VALVE WELDED BODY, CLASS 1500

Trunnion Mounted Ball Valves are designed and manufactured in conformance with API 6D, ISO 14313, ASME B16.34, API 6FA, API 607 & NACE MR01-75.

Design Features

- Sizes NPS (DN): 2”(50mm) to 48”(1200mm)
- ASME class: 1500 #
- Temperature Ratings: -29°C to 121°C (Standard)
- Design: API 6D/ISO14313, ASME B16.34
- Face to face, end to end: API 6D, ASME B16.10
- Butt weld ends: ASME B16.25
- Test: API 6D, API 598, ISO 5208
- Fire test: API 6FA, BS6755, API607
- Sour environments: NACE MR-01-75
- Seals area overlay: On request

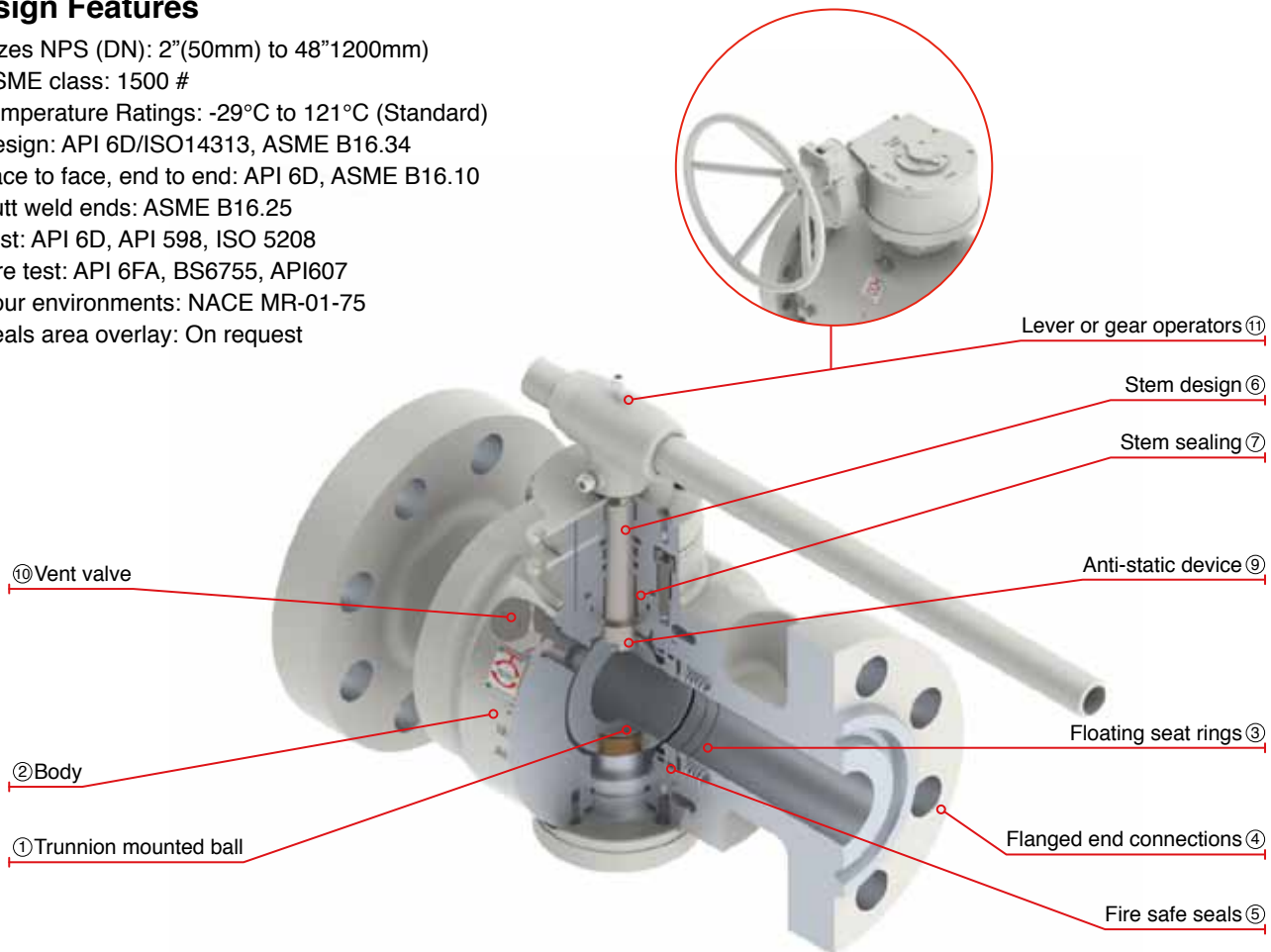

- ① Trunnion mounted ball: For all sizes & pressure ratings. The ball is fixed by an upper & lower trunnion, seat rings are dynamic which will move freely along the horizontal axis.
- ② Body. Three piece forged steel body for easy disassembly on site. Small cavities between body, seats & ball minimize the quantity of fluid that could get stored in that hollow space.
- ③ Floating seat rings. Two independent dynamic seat rings attain Bi-Directional closure of the valve these Seat. Rings are spring loaded that achieve tight shut-off at considerable low differential pressure.
- ④ Flanged ends connections. Forged steel RF or RTJ connections according to ASME B16.5 up to 24” and ASME B16.47 Series A for 26” & larger.
- ⑤ Fire safe seals: Fire safe design prevents leakage when the elastomeric seals are exposed to very high temperatures.
- ⑥ Stem design: Bottom entry anti blow out stem is made of one piece which is held up by the valve body. It has been design to avoid any possible projection due to hazardous conditions.
- ⑦ Stem sealing: Accurate machining process together with electro less nickel plated (ENP) double explosive decompression resistant (EDR) O’rings, these are supported by a secondary graphite seal which ensure reliable operation at high levels of sealing integrity when operating the valve.
- ⑧ Seats & stem emergency sealant injection (4” & larger): Valves are supplied with emergency sealant Injectors located between the double O’ring arrangement of the seat assembly & stem seal area. A highly viscous sealant is injected through these fittings to restore closure integrity.*Whenever the valve lifetime has ended or if any of the seats get damaged, the emergency sealant injection system may temporarily be used to achieve tightness before maintenance takes place.
- ⑨ Antistatic device: An inconel spring is placed between body, ball and stem to prevent static continuity.
- ⑩ Block & bleed: Double block & bleed is achieved with the valve in two positions either fully closed or fully opened.
- ⑪ Lever handle: 6” & larger valves supplied with gear operator.

TRUNNION MOUNTED BALL VALVE WELDED BODY, CLASS 1500 (LEVER OPERATED)

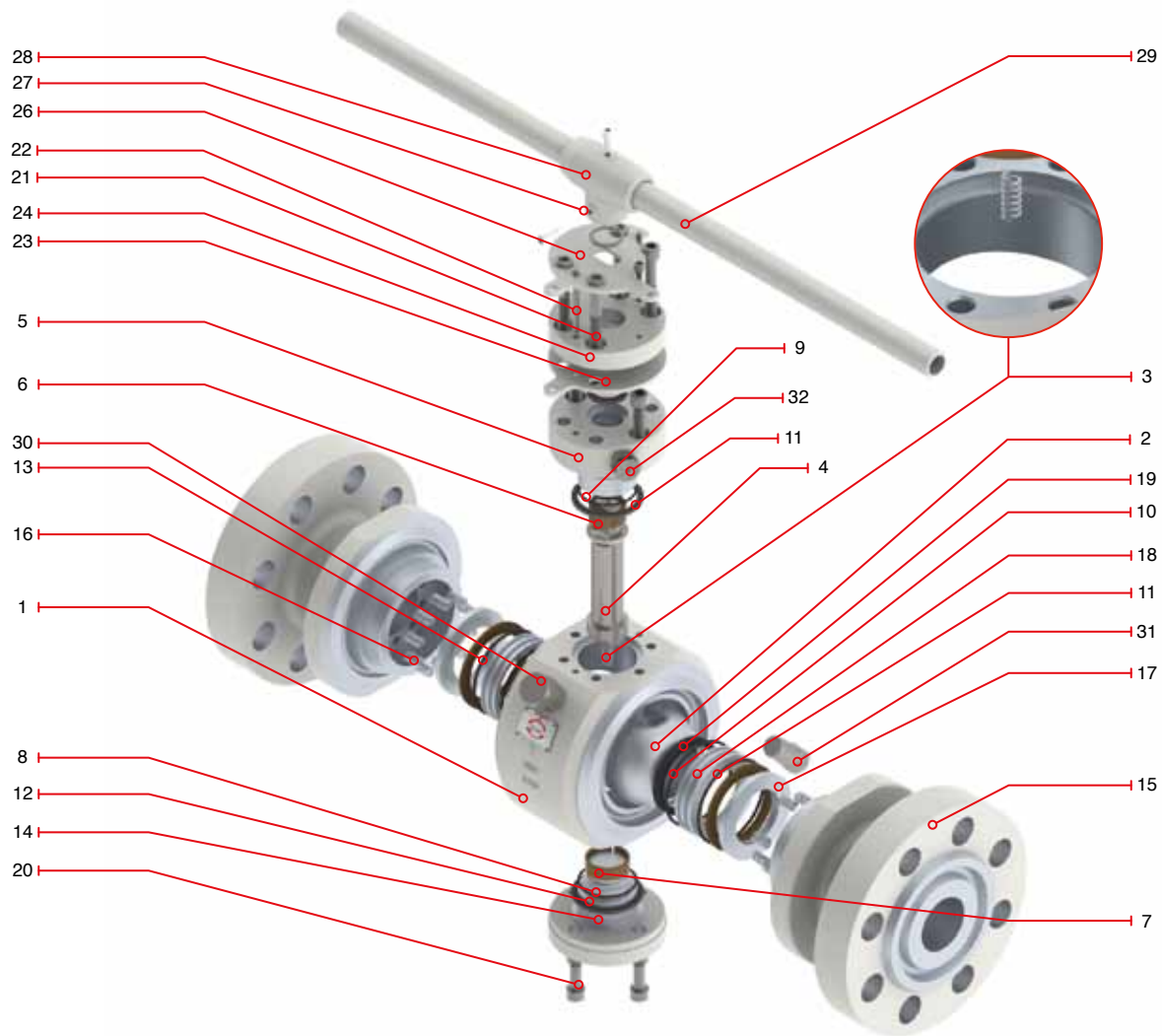

Regular Bill of Materials

No.	Description	ASTM Materials	No.	Description	ASTM Materials
1	Body	ASTM A105N	18	Seat ring	ASTM A105+75µm ENP / AISI 410
2	Ball	ASTM A105+75µm ENP / AISI 410	19	Seat insert	RPTFE
3	Antistatic spring	INCONEL X-750	20	Socket screw	ASTM A193 B7M
4	Stem	AISI 4140+75µm ENP / AISI 410	21	Socket screw	ASTM A193 B7M
5	Trunnion / bonnet	AISI 4140+75µm ENP	22	Pin	Carbon Steel
6	Upper bearing	C.S.+ PTFE LINING	23	Locking device	A36
7	Lower bearing	C.S.+ PTFE LINING	24	Packing gland flange	ASTM A216 WCB / A105
8	Lower O'ring	Viton	25	Hex. Bolt*	ASTM A193 B7M
9	Upper O'ring	Viton	26	Stop plate	A36
10	Seat O'ring	Viton	27	Retainer	AISI 1070
11	Stem fire safe gasket	Graphite	28	Handle nut	ASTM A216 WCB
12	Trunnion fire safe gasket	Graphite	29	Handle	ASTM A53
13	Seat fire safe gasket	Graphite	30	Vent valve	Carbon Steel
14	Trunnion	AISI 4140+75µm ENP / AISI 410	31	Drain plug	Carbon Steel
15	Flanged ends	A105N	32	Grease fitting	Carbon Steel
16	Seat spring	INCONEL X-750	33	Lifting lug*	A36
17	Back up seat ring	ASTM A105+75µm ENP / AISI 410	34	Support leg*	A36

* Not shown

TRUNNION MOUNTED BALL VALVE WELDED BODY, CLASS 1500 (LEVER OPERATED)

Design Features

- Side entry
- Blow out proof stem
- Soft & metal - metal seats
- Gear operated from 6" and up starting from Class 1500 #
- Three piece forged body design
- Bleed valve
- Fire safe packing
- Lifting lugs
- Heavy wall thickness
- Secondary seat injection sealant
- Draining plug



Catalog Figure No.	Type of Ends
8512-W	Raised Face (RF)
8513-W	Ring Type Joint (RTJ)
8514-W	Buttweld (WE)

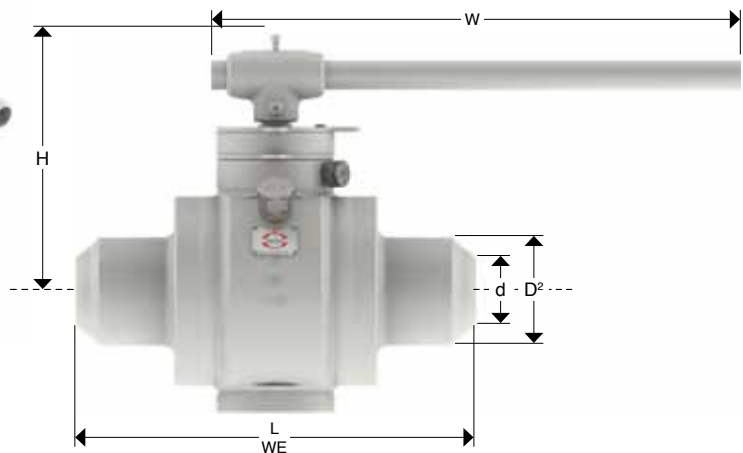
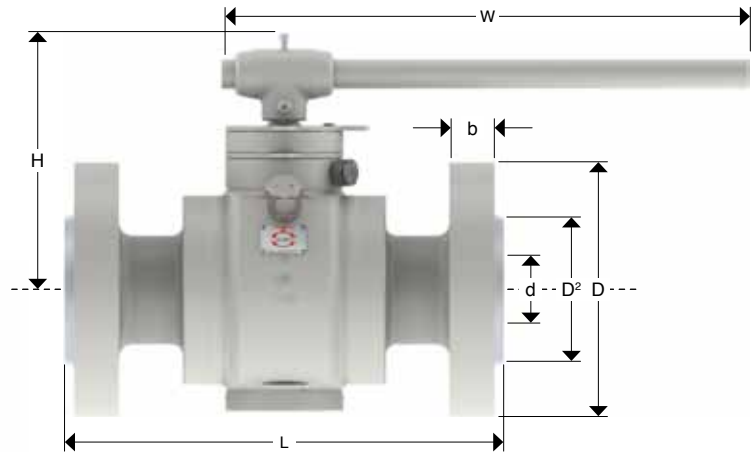

Dimensions and Weights

Nominal Diameter	mm	50	65	80
	in	2"	2 1/2"	3"
d	mm	49	62	74
	in	1.93	2.44	2.91
D	mm	216	244	267
	in	8.50	9.61	10.51
D2	mm	92	105	127
	in	3.62	4.13	5
b	mm	38.5	41.5	48
	in	1.52	1.63	1.89
L	mm	368	419	470
	in	14.50	16.50	18.50
L (WE)	mm	368	419	381
	in	14.50	16.50	14.02
H	mm	212	220	233
	in	8.37	8.68	9.19
ØW	mm	700	800	900
	in	27.56	23.62	35.43
Weight	kg	63.70	91.32	113.15
(RF - RTJ)	Lb	140.14	200.90	248.92

Key Parameters

Code	Name
d	Bore diameter
D	Flange diameter
D2	Raised face diameter
b	Flange thickness
L	Raised face and ring type joint face to face
L (WE)	Welded end face to face
H	Height
ØW	Handwheel diameter
Weight	Weight

TRUNNION MOUNTED BALL VALVE WELDED BODY, CLASS 1500 (GEAR OPERATED)

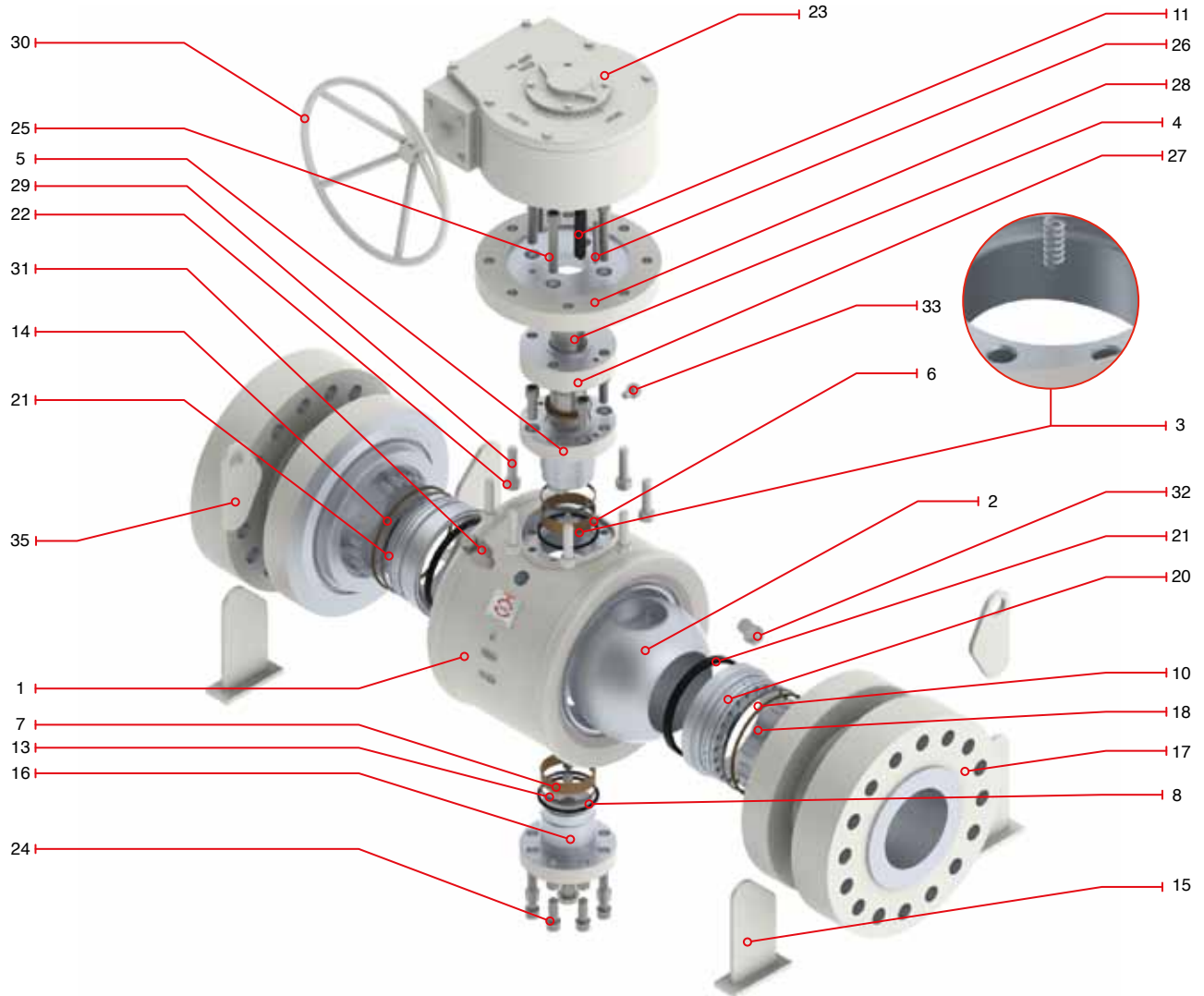

Regular Bill of Materials

No.	Description	ASTM Materials	No.	Description	ASTM Materials
1	Body	ASTM A105N	19	Back up seat ring	ASTM A105+75µm ENP / AISI 410
2	Ball	ASTM A105+75µm ENP / AISI 410	20	Seat ring	ASTM A105+75µm ENP / AISI 411
3	Antistatic spring	INCONEL X-750	21	Seat insert	RPTFE
4	Stem	AISI 4140+75µm ENP / AISI 410	22	Spring lock washer	Carbon Steel
5	Trunnion / bonnet	AISI 4140+75µm ENP	23	Gear box	Commercial steel
6	Upper bearing	C.S.+ PTFE LINING	24	Bottom socket screw	ASTM A193 B7M
7	Lower Bearing	C.S.+ PTFE LINING	25	Top socket screw	ASTM A193 B7M
8	Lower O'ring	Viton	26	Pin	ASTM A276 T410
9	Stem O'ring*	Viton	27	Packing gland bushing*	AISI 410
10	Seat O'ring	Viton	28	Packing gland flange	ASTM A216 WCB / A105
11	Key	Carbon Steel	29	Hex. Bolt	ASTM A193 B7M
12	Upper fire safe gasket*	Graphite	30	Handwheel	ASTM A53
13	Lower fire safe gasket	Graphite	31	Vent valve	AISI 4140
14	On seat fire safe gasket	Graphite	32	Drain plug	AISI 4140
15	Support leg	A36	33	Stem grease fitting	AISI 4140
16	Lower trunnion	AISI 4140+75µm ENP / AISI 410	34	Ends grease fitting*	AISI 4140
17	Flanged ends	A105N	35	Lifting lug	A36
18	Seat spring	INCONEL X-750			

* Not shown

TRUNNION MOUNTED BALL VALVE WELDED BODY, CLASS 1500 (GEAR OPERATED)

Design Features

- Side entry
- Blow out proof stem
- Soft & metal - metal seats
- Gear operated from 6" and up starting from Class 1500 #
- Three piece forged body design
- Bleed valve
- Fire safe packing
- Lifting lugs
- Heavy wall thickness
- Secondary seat injection sealant
- Draining plug



Catalog Figure No.	Type of Ends
8522-W	Raised Face (RF)
8523-W	Ring Type Joint (RTJ)
8524-W	Buttweld (WE)

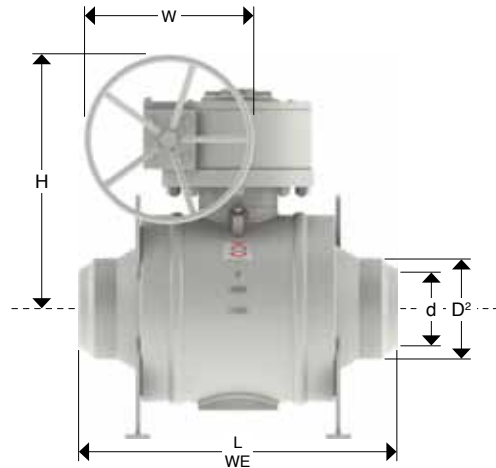
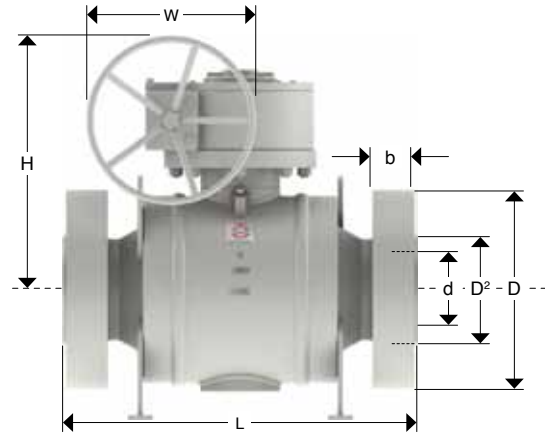

Dimensions and Weights

Nominal Diameter	mm	100	150	200	250	300	350	400	450	500	600
	in	4"	6"	8"	10"	12"	14"	16"	18"	20"	24"
d	mm	100	144	192	239	287	315	360	406	454	546
	in	3.94	5.67	7.56	9.41	11.30	12.40	14.17	15.98	17.87	21.50
D	mm	311	394	483	585	674	750	825	914	985	1168
	in	12.24	15.51	19.02	23.03	26.54	29.53	32.48	35.98	38.78	45.98
D2	mm	157	216	270	324	381	413	470	533	584	692
	in	6.18	8.50	10.63	12.76	15	16.26	18.50	20.98	23	27.24
b	mm	54	83	92	108	124	134	146.5	162	178	204
	in	2.13	3.27	3.62	4.25	4.88	5.28	5.77	6.38	7.01	8.03
L	mm	546	705	832	991	1130	1257	1384	1537	1664	1943
	in	21.50	27.76	32.76	39.02	44.49	49.49	54.49	60.51	65.51	76.50
L (WE)	mm	457	610	737	838	968	1029	1130	1219	1321	1549
	in	18	24.02	29.02	33	38	40.51	44.49	43	52.01	60.98
H	mm	275	690	758	824	856	775	937	1030	1080	1295
	in	10.84	27.17	29.84	32.44	33.7	30.51	36.89	40.55	42.52	51
ØW	mm	600	800	800	800	800	600	800	800	800	800
	in	23.62	31.50	31.50	31.50	31.50	23.62	31.50	31.50	31.50	31.50
Weight	kg	191.10	486	854.38	1492.72	2209.45	3142.68	4321	5926.33	7931.76	12135.07
(RF - RTJ)	Lb	420.42	1069.18	1879.64	3283.98	4860.80	6913.90	9506	13037.92	17449.88	26697.16

TRUNNION MOUNTED BALL VALVE WELDED BODY, CLASS 2500

Trunnion Mounted Ball Valves are designed and manufactured in conformance with API 6D, ISO 14313, ASME B16.34, API 6FA, API 607 & NACE MR01-75.

Design Features

- Sizes NPS (DN): 2”(50mm) to 48”(1200mm)
- ASME class: 2500 #
- Temperature Ratings: -29°C to 121°C (Standard)
- Design: API 6D/ISO14313, ASME B16.34
- Face to face, end to end: API 6D, ASME B16.10
- Butt weld ends: ASME B16.25
- Test: API 6D, API 598, ISO 5208
- Fire test: API 6FA, BS6755, API607
- Sour environments: NACE MR-01-75
- Seals area overlay: On request

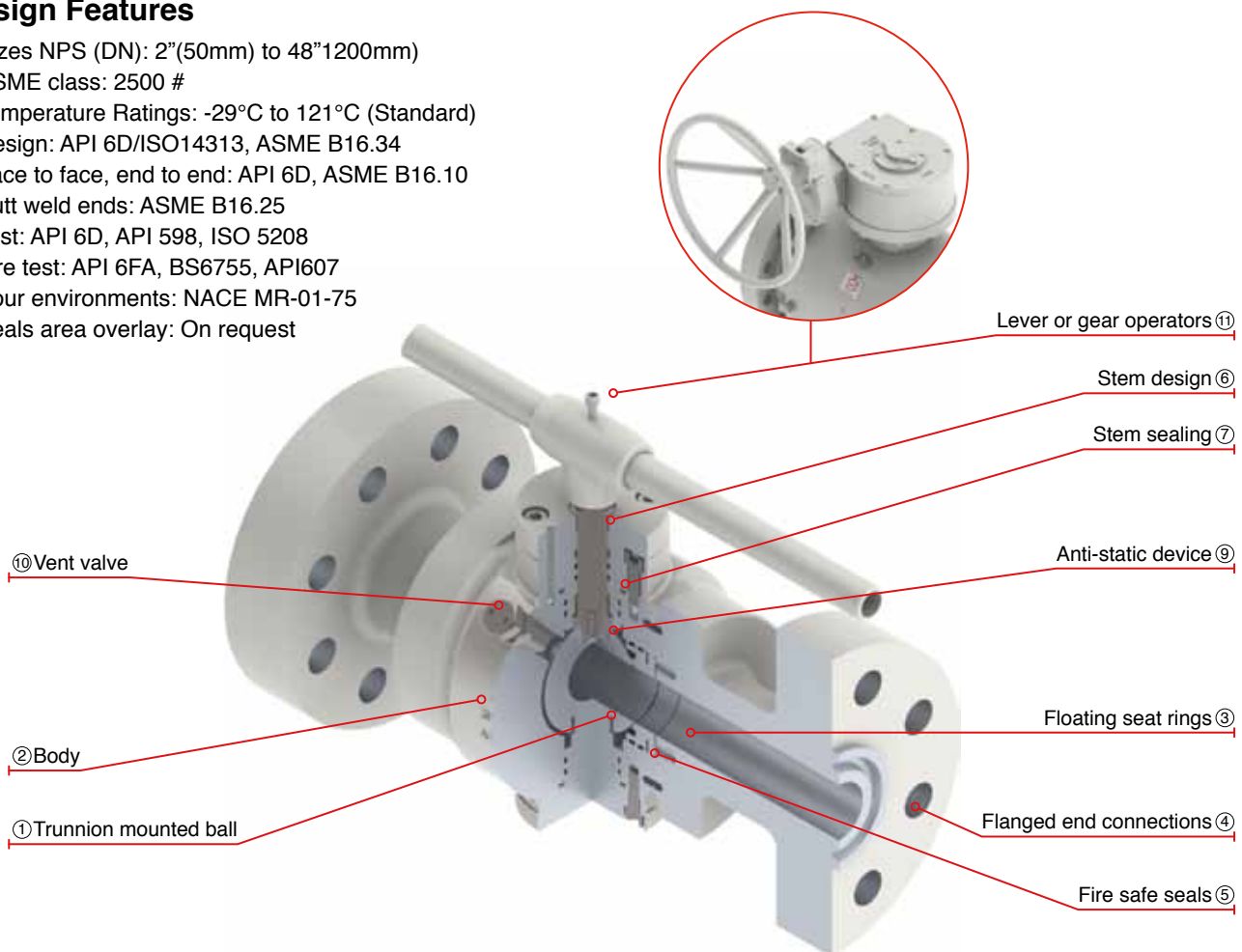

- ① Trunnion mounted ball: For all sizes & pressure ratings. The ball is fixed by an upper & lower trunnion, seat rings are dynamic which will move freely along the horizontal axis.
- ② Body. Three piece forged steel body for easy disassembly on site. Small cavities between body, seats & ball minimize the quantity of fluid that could get stored in that hollow space.
- ③ Floating seat rings. Two independent dynamic seat rings attain Bi-Directional closure of the valve these Seat. Rings are spring loaded that achieve tight shut-off at considerable low differential pressure.
- ④ Flanged ends connections. Forged steel RF or RTJ connections according to ASME B16.5 up to 24” and ASME B16.47 Series A for 26” & larger.
- ⑤ Fire safe seals: Fire safe design prevents leakage when the elastomeric seals are exposed to very high temperatures.
- ⑥ Stem design: Bottom entry anti blow out stem is made of one piece which is held up by the valve body. It has been design to avoid any possible projection due to hazardous conditions.
- ⑦ Stem sealing: Accurate machining process together with electro less nickel plated (ENP) double explosive decompression resistant (EDR) O’rings, these are supported by a secondary graphite seal which ensure reliable operation at high levels of sealing integrity when operating the valve.
- ⑧ Seats & stem emergency sealant injection (4” & larges): Valves are supplied with emergency sealant Injectors located between the double O’ring arrangement of the seat assembly & stem seal area. A highly viscous sealant is injected through these fittings to restore closure integrity.*Whenever the valve lifetime has ended or if any of the seats get damaged, the emergency sealant injection system may temporarily be used to achieve tightness before maintenance takes place.
- ⑨ Antistatic device: An inconel spring is placed between body, ball and stem to prevent static continuity.
- ⑩ Block & bleed: Double block & bleed is achieved with the valve in two positions either fully closed or fully opened.
- ⑪ Lever handle: 6” & larger valves supplied with gear operator.

TRUNNION MOUNTED BALL VALVE WELDED BODY, CLASS 2500 (LEVER OPERATED)

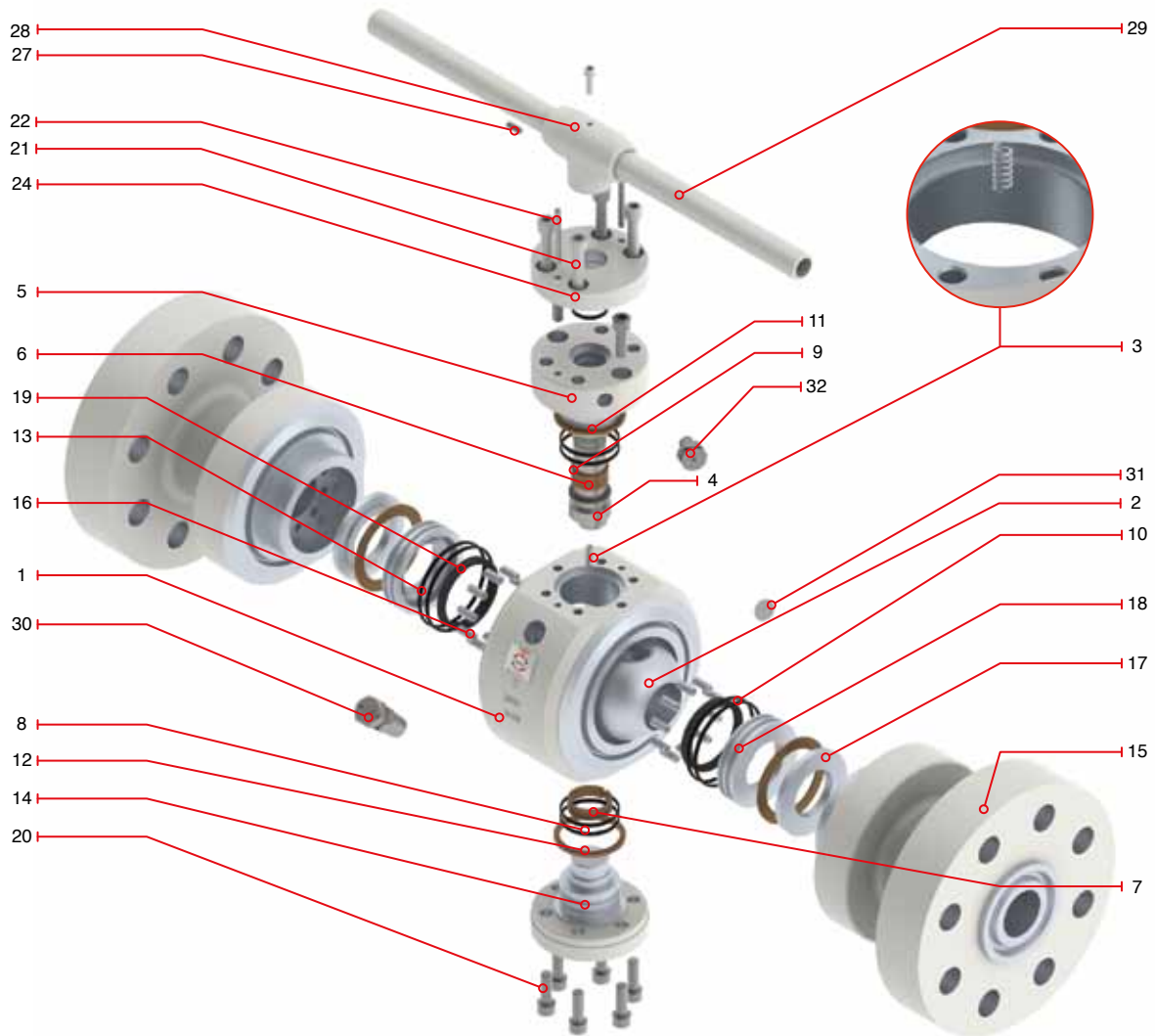

Regular Bill of Materials

No.	Description	ASTM Materials	No.	Description	ASTM Materials
1	Body	ASTM A105N	18	Seat ring	ASTM A105+75µm ENP / AISI 410
2	Ball	ASTM A105+75µm ENP / AISI 410	19	Seat insert	RPTFE
3	Antistatic spring	INCONEL X-750	20	Socket screw	ASTM A193 B7M
4	Stem	AISI 4140+75µm ENP / AISI 410	21	Socket screw	ASTM A193 B7M
5	Trunnion / bonnet	AISI 4140+75µm ENP	22	Pin	Carbon Steel
6	Upper bearing	C.S.+ PTFE LINING	23	Locking device*	A36
7	Lower bearing	C.S.+ PTFE LINING	24	Packing gland flange	ASTM A216 WCB / A105
8	Lower O'ring	Viton	25	Hex. Bolt*	ASTM A193 B7M
9	Upper O'ring	Viton	26	Stop plate*	A36
10	Seat O'ring	Viton	27	Retainer	AISI 1070
11	Stem fire safe gasket	Graphite	28	Handle nut	ASTM A216 WCB
12	Trunnion fire safe gasket	Graphite	29	Handle	ASTM A53
13	Seat fire safe gasket	Graphite	30	Vent valve	Carbon Steel
14	Trunnion	AISI 4140+75µm ENP / AISI 410	31	Drain plug	Carbon Steel
15	Flanged ends	A105N	32	Grease fitting	Carbon Steel
16	Seat spring	INCONEL X-750	33	Lifting lug*	A36
17	Back up seat ring	ASTM A105+75µm ENP / AISI 410	34	Support leg*	A36

* Not shown

TRUNNION MOUNTED BALL VALVE WELDED BODY, CLASS 2500 (LEVER OPERATED)

Design Features

- Side entry
- Blow out proof stem
- Soft & metal - metal seats
- Gear operated from 6" and up starting from Class 2500 #
- Three piece forged body design
- Bleed valve
- Fire safe packing
- Lifting lugs
- Heavy wall thickness
- Secondary seat injection sealant
- Draining plug



Catalog Figure No.	Type of Ends
8213-W	Ring Type Joint (RTJ)
8214-W	Buttweld (WE)

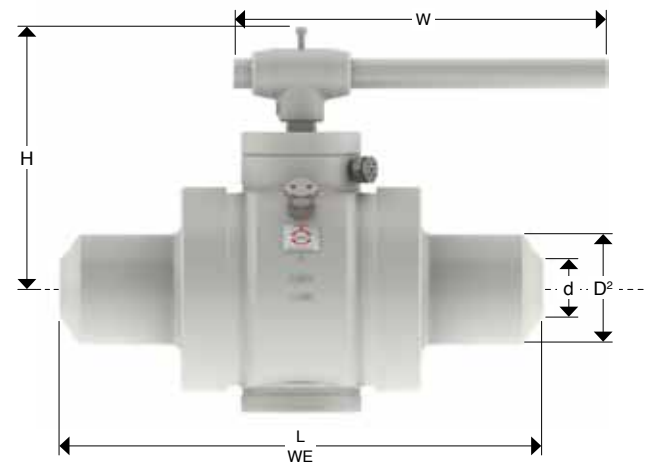
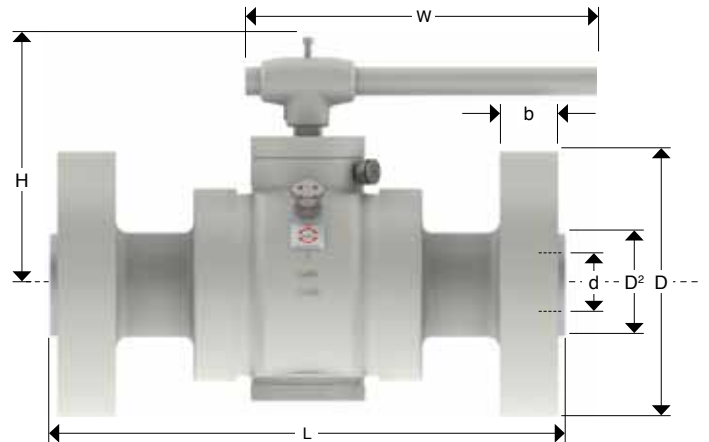

Dimensions and Weights

Nominal Diameter	mm in	50 2"	65 2 1/2"	80 3"
d	mm inch	42 1.65	52 2.05	62 2.44
D	mm inch	235 9.25	267 10.51	305 12.01
D2	mm inch	133 5.24	149 5.87	168 6.61
P	mm inch	101.6 4	111.12 4.37	127 5
E	mm inch	7.92 0.31	9.52 0.37	9.52 0.37
b	mm inch	51 2.01	58 2.28	67 2.64
L	mm inch	454 17.87	514 20.24	584 23
L (WE)	mm inch	222 8.76	240 9.46	259 10.21
H	mm inch	800 31.50	900 35.43	1000 39.37
ØW	mm inch	800 31.50	900 35.43	1000 39.37
Weight	Kg. Lb.	APM	APM	APM

APM = As per manufacturer

Key Parameters

Code	Name
d	Bore diameter
D	Flange diameter
D2	Raised face diameter
b	Flange thickness
L	Raised face and ring type joint face to face
L (WE)	Welded end face to face
H	Height
ØW	Handwheel diameter
Weight	Weight

TRUNNION MOUNTED BALL VALVE WELDED BODY, CLASS 2500 (GEAR OPERATED)

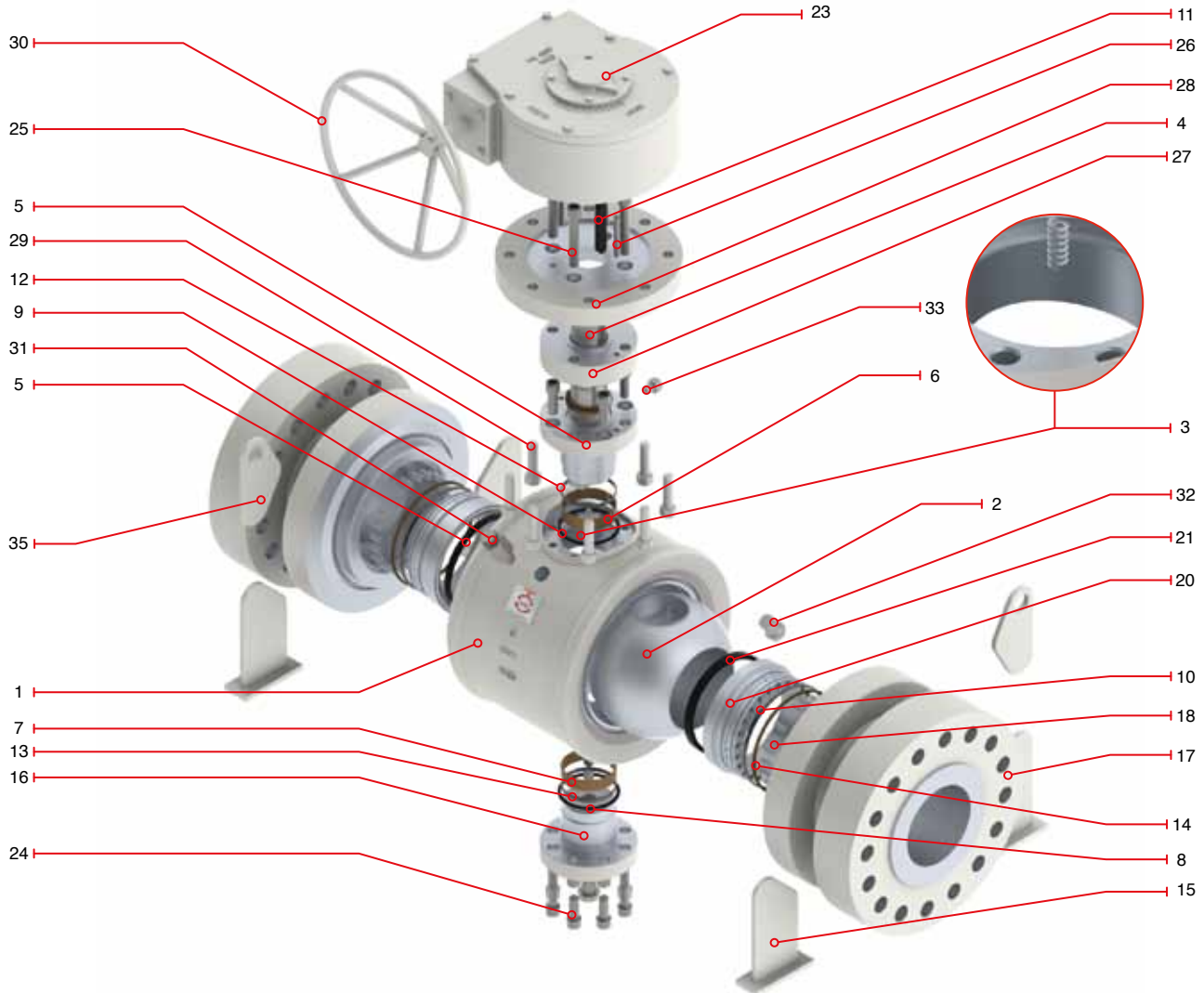

Regular Bill of Materials

No.	Description	ASTM Materials	No.	Description	ASTM Materials
1	Body	ASTM A105N	19	Back up seat ring*	ASTM A105+75µm ENP / AISI 410
2	Ball	ASTM A105+75µm ENP / AISI 410	20	Seat ring	ASTM A105+75µm ENP / AISI 411
3	Antistatic spring	INCONEL X-750	21	Seat insert	RPTFE
4	Stem	AISI 4140+75µm ENP / AISI 410	22	Spring lock washer*	Carbon Steel
5	Trunnion / bonnet	AISI 4140+75µm ENP	23	Gear box	Commercial steel
6	Upper bearing	C.S.+ PTFE LINING	24	Bottom socket screw	ASTM A193 B7M
7	Lower Bearing	C.S.+ PTFE LINING	25	Top socket screw	ASTM A193 B7M
8	Lower O'ring	Viton	26	Pin	ASTM A276 T410
9	Stem O'ring	Viton*	27	Packing gland bushing	AISI 410*
10	Seat O'ring	Viton	28	Packing gland flange	ASTM A216 WCB / A105
11	Key	Carbon Steel	29	Hex. Bolt	ASTM A193 B7M
12	Upper fire safe gasket	Graphite*	30	Handwheel	ASTM A53
13	Lower fire safe gasket	Graphite	31	Vent valve	AISI 4140
14	On seat fire safe gasket	Graphite	32	Drain plug	AISI 4140
15	Support leg	A36	33	Stem grease fitting	AISI 4140
16	Lower trunnion	AISI 4140+75µm ENP / AISI 410	34	Ends grease fitting	AISI 4140*
17	Flanged ends	A105N	35	Lifting lug	A36
18	Seat spring	INCONEL X-750			

* Not shown

TRUNNION MOUNTED BALL VALVE WELDED BODY, CLASS 2500 (GEAR OPERATED)

Design Features

- Side entry
- Blow out proof stem
- Soft & metal - metal seats
- Gear operated from 6" and up starting from Class 2500 #
- Three piece forged body design
- Bleed valve
- Fire safe packing
- Lifting lugs
- Heavy wall thickness
- Secondary seat injection sealant
- Draining plug



Catalog Figure No.	Type of Ends
8223-W	Ring Type Joint (RTJ)
8224-W	Buttweld (WE)

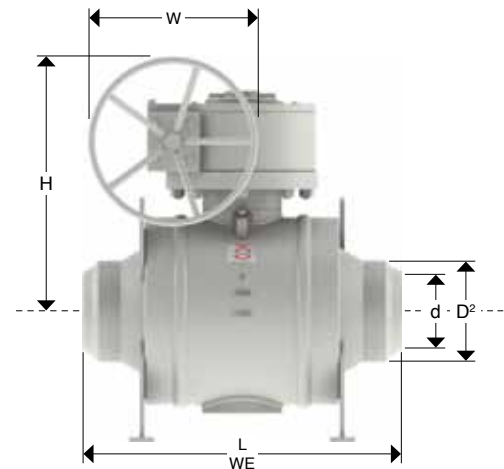
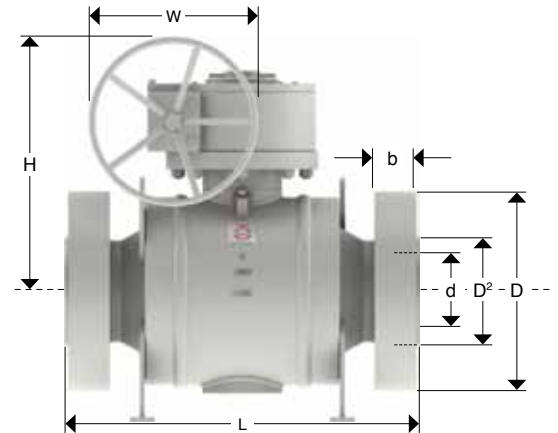

Dimensions and Weights

D Nominal Diameter	mm inch	100 4"	150 6"	200 8"	250 10"	300 12"
d	mm inch	87 3.43	131 5.16	179 7.05	223 8.78	265 10.43
D	mm inch	356 14.02	483 19.02	552 21.73	674 26.54	762 30
D2	mm inch	203 8	279 10.98	340 13.39	426 16.77	495 19.49
P	mm inch	157.18 6.19	228.6 9	279.4 11	342.9 13.50	406.4 16
E	mm inch	11.13 0.44	12.7 0.50	14.27 0.56	17.48 0.69	17.48 0.69
b	mm inch	76.5 3.01	108 4.25	127 5	165 6.50	185 7.28
L	mm inch	683 26.89	927 36.50	1038 40.87	1292 50.87	1445 56.89
L (WE)	mm inch	319 12.57	778 30.63	850 33.47	960 37.80	1080 42.52
H	mm inch	600 23.62	800 31.50	800 31.50	800 31.50	800 31.50
ØW	mm inch	600 23.62	800 31.50	800 31.50	800 31.50	800 31.50
Weight	Kg. Lb.	APM	APM	APM	APM	APM

APM = As per manufacturer

TECHNICAL INFORMATION

STEM EXTENSIONS & CONNECTIONS



There are pipe systems that run underground thus, buried valves that are not easy to reach and operate do require stem extension to facilitate access. This improvement is also recommended for services under extreme temperatures such as - 50°C or lower and 220°C or higher.

TYPES OF OPERATIONS



Gear operators



Electric operators



Pneumatic operators



Hydraulic operators

FLANGED ENDS GREASE FITTINGS

Upon customer request grease fitting are available to inject grease on seat ring sealing areas.

SIZE	CLASS					
	150	300	600	900	1500	2500
2	NO	NO	NO	NO	NO	NO
3	NO	NO	NO	NO	YES	YES
4	NO	NO	YES	YES	YES	YES
6	YES	YES	YES	YES	YES	YES
8	YES	YES	YES	YES	YES	YES
10	YES	YES	YES	YES	YES	YES
12	YES	YES	YES	YES	YES	YES
14	YES	YES	YES	YES	YES	YES
16	YES	YES	YES	YES	YES	YES
18	YES	YES	YES	YES	YES	YES
20	YES	YES	YES	YES	YES	YES
22	YES	YES	YES	YES	YES	YES
24	YES	YES	YES	YES	YES	YES
26	YES	YES	YES	YES	YES	YES
28	YES	YES	YES	YES	YES	YES
30	YES	YES	YES	YES	YES	YES
32	YES	YES	YES	YES	YES	YES
34	YES	YES	YES	YES	YES	YES
36	YES	YES	YES	YES	YES	YES
40	YES	YES	YES	YES	YES	YES
42	YES	YES	YES	YES	YES	YES
48	YES	YES	YES	YES	YES	YES

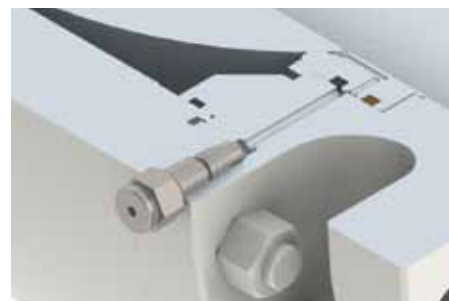

TECHNICAL INFORMATION

FULL AND REDUCED BORE



FULL PORT

A Full Bore (Full Port) valve is one where the diameter of the ball is equal in diameter to the hole of the pipe thus, if we were to observe a piece of pipe in a system which contains the valve there would not be any noticeable reduction at the location of it.

WALWORTH Standard design comes in full port, reduced port can still be supplied nonetheless.



REDUCED BORE (REDUCED PORT)

Design where the hole through the ball is smaller than the hole in the pipe; it allows minimizing flow capacity without the need of using reducers.

Normally the reduction in diameter is to the next standard size. E.g. a 2" (nominal size) reduced bore valve would have a 1.5" bore in the ball. A 1.5" (nominal size) reduced bore valve would have a 1.25" bore in the ball and so on.

GLAND FLANGE OPTION & BELLEVILLE WASHERS

In accordance with PEMEX NRF-211 or as per customer request gland flange arrangements option is available including belleville washers for live load system

Live-loading is often installed to apply a constant packing load without requiring continual retightening of the packing bolting. Live-loading is designed to compensate for packing load losses due to consolidation as well as thermal contraction and expansion. If space exists between the gland flange and the adapter flange of the valve, live-loading can be retrofitted on most linear and rotary valves. As illustrated in figure, a typical live-loading design uses disk springs (Belleville washer) above the packing flange to provide a constant load to the packing when properly torqued. The typical disk spring is a metal washer, with the inside diameter formed so that it rises higher than the outside diameter. Two disk springs are placed from inside diameter to inside diameter of bolts and stacked with other sets, allowing for a spring like configuration. Disk springs are normally made from corrosion-resistant stainless steel, although Inconel is sometimes used for highly corrosive environments.

In live-loading, the disk springs are normally compressed by the packing gland-flange, allowing a certain percentage of possible travel (typically 80 to 85 percent). As the packing volume decreases due to extrusion or friction, the disk spring's action continues to provide a load to the packing without retorquing.

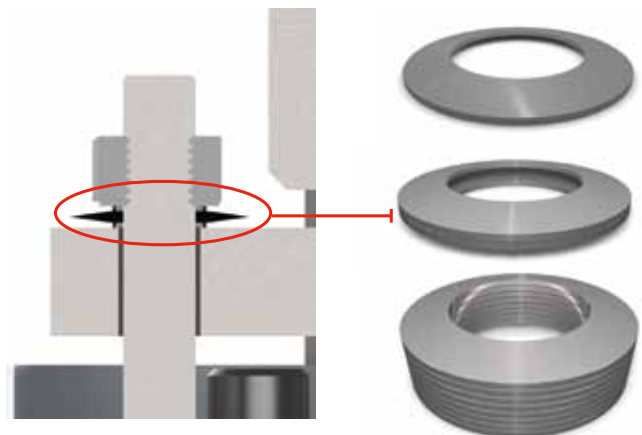
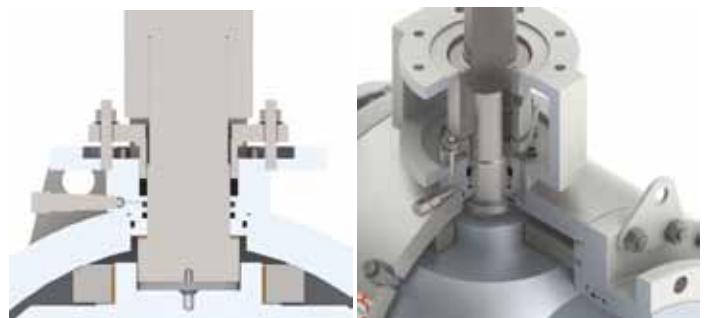

PRESSURE-TEMPERATURE RATINGS

FORGED STEEL ASTM A 105 (1)(2) AND ASTM 350 GR LF2 (1)

Temperature		MAXIMUM ALLOWABLE NON-SHOCK WORKING PRESSURE IN PSIG BY CLASS					
°F	°C	150	300	600	900	1500	2500
-20 to 100	-29 to 38	285	740	1480	2220	3705	6170
200	93	260	680	1360	2035	3395	5655
300	149	230	655	1310	1965	3270	5450
400	204	200	635	1265	1900	3170	5280
500	260	170	605	1205	1810	3015	5025
600	316	140	570	1135	1705	2840	4730
650	343	125	550	1100	1650	2745	4575
700	371	110	530	1060	1590	2665	4425
750	399	98	505	1015	1520	2535	4230
800	427	80	410	825	1235	2055	3430
850	454	65	320	640	955	1595	2655
900	482	50	230	460	690	1150	1915
950	510	35	135	275	410	685	1145
1000	538	20	85	170	255	430	715

(1) Upon prolonged exposure to temperatures above 425°C, the carbide phase of steel may be converted to graphite. Permissible, but not recommended for prolonged usage above 425°C.

(2) Only killed steel shall be used above 455°C.

(a) Flanged End Valve ratings terminate at 1000°F.

FORGED STEEL ASTM A 182 GR F11

Temperature		MAXIMUM ALLOWABLE NON-SHOCK WORKING PRESSURE IN PSIG BY CLASS					
°F	°C	150	300	600	900	1500	2500
-20 to 100	-29 to 38	290	750	1500	2250	3750	6250
200	93	260	750	1500	2250	3750	6250
300	149	230	720	1445	2165	3610	6015
400	204	200	695	1385	2080	3465	5775
500	260	170	665	1330	1995	3325	5540
600	316	140	605	1210	1815	3025	5040
650	343	125	590	1175	1765	2940	4905
700	371	110	570	1135	1705	2840	4730
750	399	95	530	1065	1595	2660	4430
800	427	80	510	1015	1525	2540	4230
850	454	65	485	975	1460	2435	4060
900	482	50	450	900	1350	2245	3745
950	510	35	320	640	955	1595	2655
1,000	538	20	215	430	650	1080	1800
1,050	566	20(*)	145	290	430	720	1200
1,100	593	20(*)	95	190	290	480	800
1,150	621	20(*)	65	130	195	325	545
1,200	649	15(*)	40	80	125	205	345

(*) Use normalized and tempered material only.

(*) Permissible, but not recommended for prolonged use above 595°C.

(a) Flanged End Valve ratings terminate at 1000°F.

FORGED STEEL ASTM A 182 GR F91

Temperature		MAXIMUM ALLOWABLE NON-SHOCK WORKING PRESSURE IN PSIG BY CLASS					
°F	°C	150	300	600	900	1500	2500
-20 to 100	-29 to 38	290	750	1500	2250	3750	6250
200	93	260	750	1500	2250	3750	6250
300	149	230	730	1455	2185	3640	6070
400	204	200	705	1410	2115	3530	5880
500	260	170	665	1330	1995	3325	5540
600	316	140	605	1210	1815	3025	5040
650	343	125	590	1175	1765	2940	4905
700	371	110	570	1135	1705	2840	4730
750	399	95	530	1065	1595	2660	4430
800	427	80	510	1015	1525	2540	4230
850	454	65	485	975	1460	2435	4060
900	482	50	450	900	1350	2245	3745
950	510	35	385	755	1160	1930	3220
1,000	538	20	365	725	1090	1820	3030
1,050	566	20(*)	360	720	1080	1800	3000
1,100	593	20(*)	300	605	905	1510	2515
1,150	621	20(*)	225	445	670	1115	1855
1,200	649	20(*)	145	290	430	720	1200

* At temperatures above 538°C, use only when the carbon content is 0.04% or higher.

(a) Flanged End Valve ratings terminate at 1000°F.

PRESSURE-TEMPERATURE RATINGS

FORGED STEEL ASTM A 182 GR F316

Temperature		MAXIMUM ALLOWABLE NON-SHOCK WORKING PRESSURE IN PSIG BY CLASS					
°F	°C	150	300	600	900	1500	2500
-20 to 100	-29 to 38	275	720	1440	2160	3600	6000
200	93	235	620	1240	1860	3095	5160
300	149	215	560	1120	1680	2795	4660
400	204	195	515	1025	1540	2570	4280
500	260	170	480	955	1435	2390	3980
600	316	140	450	900	1355	2255	3760
650	343	125	440	885	1325	2210	3680
700	371	110	435	870	1305	2170	3620
750	399	95	425	855	1280	2135	3560
800	427	80	420	745	1265	2110	3520
850	454	65	420	735	1255	2090	3480
900	482	50	415	730	1245	2075	3460
950	510	35	385	775	1160	1930	3220
1000	538	20	365	725	1090	1820	3030
1050	566	20	360	720	1080	1800	3000
1100	593	20(*)	305	610	915	1525	2545
1150	621	20(*)	235	475	710	1185	1970
1200	649	20(*)	185	370	555	925	1545
1250	677	20(*)	145	295	440	735	1230
1300	704	20(*)	115	235	350	585	970
1350	732	20(*)	95	190	290	480	800
1400	760	20(*)	75	150	225	380	630
1450	788	20(*)	60	115	175	290	475
1500	816	15(*)	40	85	125	205	345

Note: At temperatures over 1,000°F, use only when the carbon content is 0.04% or higher.

FORGED STEEL ASTM A 182 GR F316L

Temperature		MAXIMUM ALLOWABLE NON-SHOCK WORKING PRESSURE IN PSIG BY CLASS					
°F	°C	150	300	600	900	1500	2500
-20 to 100	-29 to 38	230	600	1200	1800	3000	5000
200	93	195	510	1020	1535	2555	4260
300	149	175	455	910	1370	2280	3800
400	204	160	420	840	1260	2100	3500
500	260	140	370	745	1115	1860	3100
600	316	125	365	730	1095	1825	3040
650	343	110	360	720	1080	1800	3000
700	371	80	345	690	1035	1730	2880
750	399	65	340	675	1015	1690	2820

FORGED STEEL ASTM A 182 GR F44 & F51

Temperature		MAXIMUM ALLOWABLE NON-SHOCK WORKING PRESSURE IN PSIG BY CLASS					
°F	°C	150	300	600	900	1500	2500
-20 to 100	-29 to 38	290	750	1500	2250	3750	6250
200	93	260	745	1590	2230	3720	6200
300	149	230	665	1335	2000	3335	5560
400	204	200	615	1230	1845	3070	5120
500	260	170	580	1160	1740	2905	4840
600	316	140	555	115	1670	2785	4640
650	343	125	545	1095	1640	2735	4560
700	371	110	540	1085	1625	2710	4520
750	399	95	530	1065	1595	2660	4430

* STEEL ASTM A 182 GR F51 steel may become brittle after service at moderately elevated temperatures. Not to be used over 600°F.

DESIGN BASIS

All of WALWORTH's valve designs, when applicable, follow one or more of the following standards:

API Standards American Petroleum Institute:

- **API-6D** Steel gate, ball and plug valves for pipeline service
- **API-598** Valve inspection and testing
- **API-6FA** Specification for fire test for valves

ANSI Standards National Standards Institute:

- **B16.5** Steel pipe flanges and flanged fittings
- **B16.10** Length of ferrous flanged and welding end valves
- **B16.25** Butt-welding ends
- **B18.2** Square and hexagon bolts and nuts
- **B16.47** Larger diameter steel flanges

MSS Standards Manufacturer's Standardization Society:

- **MSS SP-6** Standard finishes for contact faces of pipeline flanges and connecting end flanges of valves and fittings
- **MSS SP-9** Spot facing for bronze, iron and steel flanges
- **MSS SP-25** Standard marking system for valves, fittings, flanges and unions
- **MSS SP-44** Steel pipeline flanges
- **MSS SP-45** Bypass and drain connections
- **MSS SP-55** Quality standard for steel castings for valves, flanges and fittings and other piping components - visual method for eval of surface irregularities

ASTM Standards American Society for Testing and Materials:

- **ASTM A 105** Standard Specification for Carbon Steel Forgings for Piping Applications
- **ASTM A 193** Standard specification for alloy-steel and stainless steel bolting materials for high temperature service
- **ASTM A 194** Standard specification for carbon and alloy-steel nuts for bolts high-pressure and high-temperature service
- **ASTM A 216** Standard specification for steel castings, carbon, suitable for fusion welding, for high-temperature service
- **ASTM A 276** Standard specification for stainless and heat-resisting steel bars and shapes
- **ASTM A 351** Standard specification for castings, austenitic, austenitic-ferritic (duplex), for pressure-containing parts
- **ASTM A 352** Standard specification for steel castings, ferritic and martensitic, for pressure-containing parts, suitable for low temperature service
- **ASTM A 515** Standard specification for pressure vessel plates, carbon steel, for intermediate and higher-temperature service

NACE Standards National Association of Corrosion Engineers:

- **NACE MR0175** Standard material requirements sulfide stress cracking resistant metallic materials for oilfield equipment

ASME Code American Society of Mechanical Engineers:

- **ANSI/ASME B31.1** Power piping
- **ANSI/ASME B31.2** Fuel Gas piping
- **ANSI/ASME B31.3** Process piping
- **ANSI/ASME B1.20.1** Pipe threads. General Purpose (inch)

Boiler and pressure vessel code:

- **Section II** Parts A, B and C
- **Section V** Non destructive examination
- **Section VIII** Rules for construction of pressure vessels, divisions 1 and 2
- **Section IX** Welding and brazing qualifications

FIGURE CODING FOR TRUNNION BALL VALVES



MODEL	ANSI CLASS	ACTUATION	ENDS	SUFFIXES (ADDERS)				
8 Fire Safe Trunnion Ball Valve	1	150	1	Lever	2	Raised Face	R	Reduced Bore
	2	2500	2	Gear Box	3	Ring Type Joint	W	Welded Body
	3	300	3	Actuator	4	Welded Ends	B	Bi-directional seats
	5	1500	4	Double Speed Gear Box			M	Mixed seats
	6	600	5	Bare Stem To Receive Actuation				
	9	900						

EXAMPLES

8112	Fire Safe Trunnion Ball Valve, 150# Class, Lever Operated, Raised Face Flanged Ends
8223-R	Fire Safe Trunnion Ball Valve, 2500# Class, Gear Box Operated, Ring Type Joint, Reduced Bore
8644-WB	Fire Safe Trunnion Ball Valve, 600# Class, Double Speed Gear Box Operated, Welded Ends, Welded Body, Bi-directional Seats.

HOW TO ORDER

WALWORTH Valves are identified by a figure number which describes main features. Identification procedure is intended to assist customers to specify the sort of valve required according to a specific need.

8 1 2 2 - W - T3 - A105



SIZE (INCH)	WALWORTH FIGURE				SUFIXES	TRIM (Ball stem, trunnions & seat rings)	BASE MATERIAL ASTM
2"	8112	150 #	WRENCH	RF	R = Reduced Bore	T1	CARBON STEELS:
3"	8113	150 #	WRENCH	RTJ	B = Bi-Directional Seats	T2	A105N
4"	8114	150 #	WRENCH	WE	W = Welded Ends	T3	A350-LF2
6"	8122	150 #	GEAR OPERATOR	RF	M = Mixed Seats (Metal to Metal - Soft)	T4	A182-F1
8"	8123	150 #	GEAR OPERATOR	RTJ		T5	A182-F5
10"	8124	150 #	GEAR OPERATOR	WE		T6	A182-F5a
12"	8132	150 #	ACTUATOR	RF			A182-F9
14"	8133	150 #	ACTUATOR	RTJ			A182-F11
16"	8134	150 #	ACTUATOR	WE			A182-F22
18"	8312	300 #	WRENCH	RF			LOW CARBON STAINLESS STEELS:
20"	8313	300 #	WRENCH	RTJ			A182-F304L
22"	8314	300 #	WRENCH	WE			A182-F316L
24"	8322	300 #	GEAR OPERATOR	RF			STAINLESS STEELS:
26"	8323	300 #	GEAR OPERATOR	RTJ			A182-F304
28"	8324	300 #	GEAR OPERATOR	WE			A182-F316
30"	8332	300 #	ACTUATOR	RF			LOW CARBON STEELS
32"	8333	300 #	ACTUATOR	RTJ			A350-LF1
34"	8334	300 #	ACTUATOR	WE			A350-LF2
36"	8612	600 #	WRENCH	RF			A350-LF3
	8613	600 #	WRENCH	RTJ			NICKEL ALLOYS:
	8614	600 #	WRENCH	WE			B564-N0 4400 (MONEL 400)
	8622	600 #	GEAR OPERATOR	RF			B564-UNS 8810 (INCOLOY 800H)
	8623	600 #	GEAR OPERATOR	RTJ			B564-UNS 8825 (INCOLOY 825)
	8624	600 #	GEAR OPERATOR	WE			B564-UNS 6600 (INCONEL 600)
	8632	600 #	ACTUATOR	RF			B564-UNS 6625 (INCONEL 625)
	8633	600 #	ACTUATOR	RTJ			B564-N0 6022 (HASTELLOY C22)
	8634	600 #	ACTUATOR	WE			B564-N 10276 (HASTELLOY C276)
	8912	900 #	WRENCH	RF			DUPLEX STAINLESS STEEL:
	8913	900 #	WRENCH	RTJ			A182-F51
	8914	900 #	WRENCH	WE			SUPER DUPLEX STAINLESS STEEL:
	8922	900 #	GEAR OPERATOR	RF			A182-F55
	8923	900 #	GEAR OPERATOR	RTJ			
	8924	900 #	GEAR OPERATOR	WE			
	8932	900 #	ACTUATOR	RF			
	8933	900 #	ACTUATOR	RTJ			
	8934	900 #	ACTUATOR	WE			
	8512	1500 #	WRENCH	RF			
	8513	1500 #	WRENCH	RTJ			
	8514	1500 #	WRENCH	WE			
	8522	1500 #	GEAR OPERATOR	RF			
	8523	1500 #	GEAR OPERATOR	RTJ			
	8524	1500 #	GEAR OPERATOR	WE			
	8532	1500 #	ACTUATOR	RF			
	8533	1500 #	ACTUATOR	RTJ			
	8534	1500 #	ACTUATOR	WE			
	8212	2500 #	WRENCH	RF			
	8213	2500 #	WRENCH	RTJ			
	8214	2500 #	WRENCH	WE			
	8222	2500 #	GEAR OPERATOR	RF			
	8223	2500 #	GEAR OPERATOR	RTJ			
	8224	2500 #	GEAR OPERATOR	WE			
	8232	2500 #	ACTUATOR	RF			
	8233	2500 #	ACTUATOR	RTJ			
	8234	2500 #	ACTUATOR	WE			

SUPPLEMENTARY REQUIREMENTS
R = Reduced Bore
B = Bi-Directional Seats
W = Welded Ends
M = Mixed Seats (Metal to Metal - Soft)
POV= Pneumatic operated valve.
LD= Locking device.
NACEMR-01-75.
NACEMR-01-03
NACW for low temperature.
SP= Special Paint.
SG= Special Gasket.
SPK= Special Packing.
VOC= Certification of Volatile
Organic Compounds
GO= Gear operator.
MOV= Motor operated valve.

NOTE: ADDITIONAL BASE MATERIALS & TRIMS ARE AVAILABLE UPON REQUEST.

ENDS
RF = RAISED FACE
RTJ = RING TYPE JOINT
WE = WELD ENDS

MODEL	PRESSURE	OPERATOR	ENDS	Trim
	1 = 150	1 = WRENCH	2 = RAISED FACED	T1
8 = API-6D BALL	3 = 300	2 = GEAR OPERATOR	3 = RING TYPE JOINT	T3
	6 = 600	3 = PNEUMATIC ACTUATOR	4 = BUTT WELD	T4
	9 = 900	4 = ELECTRIC ACTUATOR		T5
	5 = 1500			
	2 = 2500			

THE WALWORTH COMPANY GENERAL TERMS AND CONDITIONS

ACCEPTANCE: All quotations are for acceptance within 30 days from date of quotation unless extended in writing. In the event a purchase order is placed after this period of time. The Walworth Company reserves the right to requote base prices of all valves offered. All orders and contracts are subject to credit approval and acceptance by the Walworth Company.

FREIGHT: When prices are f.o.b. point of shipment –no freight allowance, we will attempt to route shipments in the method which will result in the lowest cost unless otherwise instructed. All shipments will be freight charges collect except when stipulated on the purchase order, in which case you will be invoiced for all transportation charges. Delivery of material to a common carrier shall be considered to be delivery to Buyer and shall be at Buyer's risk thereafter. Claims of loss of or damage to material in transit shall be filed by the Buyer directly with the carrier.

PRICES: There will be added to all prices quoted sales, use, occupation or any other excise or similar tax which Seller may be required to pay or collect on or in connection with the sale. Seller shall be established by Federal, State or other government regulation with respect to the product(s) Tapaed by the order which shall be lower than the price(s) specified in the order.

ESCALATION TERMS: Prices shown in this price schedule reflect the costs in effect at the time of publication. These prices will remain firm on all products with a quoted delivery of twenty–six (26) weeks or less. On products which have a scheduled delivery of more than twenty-six (26) weeks, the goods will be invoiced based on the applicable price sheet in effect at the time of shipment. In no event will the invoiced price be less than the price originally quoted.

PURCHASED COMPONENTS: (i.e. motors, gearing, etc.) Prices are quoted on supplier price in effect at time of quotation. Actual invoice Price will be adjusted in accordance with the supplier's escalation policy.

DEFERRED SHIPMENTS: If for any reason the customer desires to delay shipments more than 30 days after manufacturing is complete or to place a hold or stop to the order during the manufacturing cycle, The Walworth Company reserves the right to consider the order cancelled and to invoke cancellation charges per the schedule below.

CANCELLATION: After order acceptance by Walworth, items or completed orders may be cancelled and buyer will be charged for work performed, based on the following schedule:

- Five (5%) percent of prices of stock items.
- Ten (10%) percent of price of stock items ordered in quantities which exceed normal inventory levels.
- Five (5%) percent of prices prior to drawing submittal on made-to-order items.
- 15% after drawing approval, but prior to the start of castings.
- 30% to 50% during casting cycle, depending on the state of completion.
- 55% to 75% during machining and assembly operations, depending on the state of completion.
- 100% after final assembly and test.

REMITTANCES: Remittances must be made to the address indicated on the invoice.

CREDIT TERMS: As quoted. Invoices on balances overdue will be subject to a service charge of 11/2 % per month on such indebtedness.

DELIVERIES: Shipments and deliveries shall at all times be subject to the approval of Seller's Credit Department. If the Buyer shall fail to make any payments according to the terms of the contract, Seller may, in addition to and not in limitation of its other rights and remedies, at its option, cancel all or any part of Buyer's incomplete contracts with Seller or may defer shipments of deliveries under Buyer's contracts with Seller except upon receipt of satisfactory security or for cash shipment.

All schedule of shipments are estimated as closely as possible and Seller will use its best efforts to ship within the time scheduled, but does not guarantee to do so. Schedules commence with the date Seller receives authorization to proceed with order, subject to the provisions of the next sentence. The order will not be released for manufacture until complete specifications and approved drawings (if drawing approval is required) are received at the plant of manufacture and the estimated shedule of shipment will commence with the date of such receipt.

Seller shall not be liable for any direct, indirect or consequential damage or loss caused by any delay in delivery, regardless of the cause of delay.

Without limiting the generality of the foregoing, Seller assumes no responsibility for delays in delivery resulting from fire, flood, accidents, riots, strikes, transportation delays, labor or material shortages, existing or future laws, acts of any governmental authority, or any other cause beyond Seller's control. Items offered from stock are subject to prior sale.

INSPECTION: Final inspection and acceptance of products must be made at the plant of manufacture, unless otherwise provided in the order and/ or in agreed upon specifications. Prices do not include charges for special tests or inspections performed at the request of the Buyer, unless called for in the order and/or in agreed upon specifications.

RETURNS: Permission in writing and return tagging instructions must be obtained from Seller before any goods returned for credit or adjustment will be acceptance. Where returned goods are accepted, a minimum charge of 25% of the invoice price will be made, plus freight from both directions and costs of reconditioning the material for resale as new.

WARRANTY: Seller will replace without charge or refund the purchase price of products manufactured by Seller which prove to be defective in the material or workmanship , provided in each case that the product is properly installed and is used in the service for which Seller recommends it and that written claim, specifying the alleged defect, is presented to Seller shall in no event be responsible for (a) claims for labor, expenses or other damages occasioned by defective products or (b) for consequences or secondary damages. THE WARRANTY STATED IN THIS PARAGRAPH IS IN LIEU OF ALL OTHER WARRANTIES, EITHER EXPRESSED OR IMPLIED. WITH RESPECT TO WARRANTIES THIS PARAGRAPH STATES BUYER'S EXCLUSIVE REMEDY AND SELLER'S EXCLUSIVE LIABILITY.

DESIGN, ETC: Seller reserves the right to change design, materials or specifications without notice. There will be a charge for modifying an order after it has been entered when such change or modification results in additional engineering or clerical work for either The Walworth Company or our suppliers.

MINIMUM CHARGE: Orders totaling less than \$100.00 net will be billed at a minimum charge of %100.00. Repair parts will be billed at a minimum charge of \$50.00.

NOTE: We reserve the right to correct obvious clerical errors in quotations, invoices, and other contracts.



WALWORTH®

Since 1842



Visit our website for more detail information
www.walworthvalves.com

MEXICO

Industrial de Válvulas, S.A. de C.V.
Av. de la Industria Lote 16
Fracc. Industrial El Trébol, C.P. 54600
Tepetzotlán, Estado de México

Phone: (52 55) 5899 1700
Fax: (52 55) 5876 0156

e-mail: info@walworth.com.mx

USA

TWC The Valve Company
Authorized Distributor
13641 Dublin Court, Stafford, Texas 77477

Phone: (713) 996 9696
Toll Free: (1 800) 697 1842
Fax: (713) 996 9669

e-mail: info@twcousa.com