



**WALWORTH**®

*Since 1842*



**CAST STEEL**

**CATALOG**



# INDEX

## Introduction

WALWORTH Engineering Control.....	5
WALWORTH Quality System.....	5
Quality Control Equipment.....	9

## Cast Steel Gate, Globe and Swing Check Valves

CAST STEEL BOLTED BONNET VALVES BODY MATERIALS .....	12
WALWORTH CAST STEEL VALVES TRIM ARRANGEMENTS .....	16
COMMON CONSTRUCTION MATERIALS COMBINATION .....	18
WALWORTH CAST STEEL GATE VALVES CLASS 150 .....	19
WALWORTH CAST STEEL GATE VALVES CLASS 300 .....	24
WALWORTH CAST STEEL GATE VALVES CLASS 600 .....	29
WALWORTH CAST STEEL GATE VALVES CLASS 900 .....	34
WALWORTH CAST STEEL GATE VALVES CLASS 1500 .....	39
WALWORTH CAST STEEL GLOBE VALVES CLASS 150 .....	44
WALWORTH CAST STEEL GLOBE VALVES CLASS 300 .....	49
WALWORTH CAST STEEL GLOBE VALVES CLASS 600 .....	54
WALWORTH CAST STEEL GLOBE VALVES CLASS 900 .....	59
WALWORTH CAST STEEL GLOBE VALVES CLASS 1500 .....	64
WALWORTH CAST STEEL SWING CHECK VALVES CLASS 150 .....	69
WALWORTH CAST STEEL SWING CHECK VALVES CLASS 300 .....	72
WALWORTH CAST STEEL SWING CHECK VALVES CLASS 600 .....	75
WALWORTH CAST STEEL SWING CHECK VALVES CLASS 900 .....	78
WALWORTH CAST STEEL SWING CHECK VALVES CLASS 1500 .....	81
TECHNICAL INFORMATION .....	84
PRESSURE-TEMPERATURE RATINGS .....	92
DESIGN BASIS .....	96
HOW TO ORDER .....	97
GENERAL TERMS AND CONDITIONS .....	98



YARMOUTH RESEARCH AND TECHNOLOGY



# WALWORTH COMPANY

**WALWORTH** Company is one of the world's most dominant and comprehensive global industrial valve manufacturers and marketers. Founded in 1842 by James Walworth, the Company has consistently dedicated itself to the design and manufacture of an array of valves exceptionally suited for the world's fluid control sector. We satisfy all end use industries and comprehensive customer requirements by adhering to the most demanding quality standards.

**WALWORTH** relies on its broad experience in supplying valves to the petrochemical, oil & gas, petroleum, power generation, pulp and paper, cryogenic and geothermal industries, among others. Over the years, the Company has produced more than 40,000 different types of products and serves as a global supplier to varied markets utilizing the expertise of over 500 trained employees. **WALWORTH** retains facilities in the United States, Mexico and China for the complete range of valves and flow control instruments required.

The Company is unrivaled in its total approach to manufacturing. This includes utilization of Company - directed raw material warehouses, up-to-date specialized machinery, welding processes such as SMAW, GMAW, SAW, PAW; and assembly testing for low pressure, high pressure, at low or high temperature, painting process, crating and shipment. With Company-directed facilities and stocks in the United States and Mexico, **WALWORTH** is capable of providing the world's most comprehensive industrial valve line to the North American, Central American, South American, European and African markets. With Company-owned facilities in China, Walworth is serving Asia, the Middle East, Far East and Australia, today's fastest growing industrial arena in the world. Walworth is proud to meet the ultimate demands of customer satisfaction, especially in quality, cost effectiveness and services in all parts of the world.



## WALWORTH VALUES

### MISSION

To satisfy the needs of Customers in terms of quality and service and comply with expectations of employees, suppliers and share holders.

### VISION

To maintain our good reputation in terms of service, delivery and quality which has been the main goal during all these years that has positioned **WALWORTH** brand as a reliable Company for over 167 years in the market. To continue developing new products according to the needs of the market in terms of technology, environment and quality requirements. **WALWORTH** does manufacture valves, but at the same time gives service to our Customers.

# WALWORTH ENGINEERING CONTROL

**WALWORTH** products are manufactured following strictly the most recognized international standards all over the world, such as API, ANSI, ASME, ASTM, MSS, NACE, AWWA, BSI, CSA, among others. Our Engineering team is always studying the new updates of these standards to incorporate any changes that may affect the design, regulations or performance of our products, being leaders in the new developments achieved. Design is made using the most advanced technology and equipment, using finite elements and CAD system programs to ensure the proper assembly and performance of products since the concept, calculation and detailed drawings for manufacturing. **WALWORTH** is a leader in the development of new products according to valve market current needs.



## WALWORTH QUALITY SYSTEM

Throughout the years, **WALWORTH** has developed its Quality System which is an integral part of our manufacturing policy. Our primary goal is to provide products that meet and exceed market standards. In this sense, **WALWORTH** is an ISO-9001 Audited and Certified Company that has achieved major certifications worldwide. Our system consists of a rigorous quality control as well as the selection of raw materials from approved vendors. Control over our manufacturing process is vital. Serial numbers allow **WALWORTH** to monitor and trace fabrication processes along with the materials of components.



- Certificate API-6D No. 6D-0097 issued by American Petroleum Institute to apply on Gate valves, Plug valves, Ball valves and Check valves manufactured in accordance with API-6D specification.



- Certificate API-6A No. 6A-0234 from American Petroleum Institute to apply on valves at PSI, 1 through 4.



• Certificate ISO-9001 No. 038 issued by American Petroleum Institute since April 1999.



• Certificate as per PED 97/23/EC Module H to stamp CE products.



• Certificate of Reliable Supplier No. 199/07 issued by CFE in accordance with ISO-9001 Quality Assurance System.



• Certificate NMX-CC-9001 (Mexican Standards ISO-9001) No. 0552/2007 issued by PEMEX in accordance with ISO-9001 Quality Assurance System.

**Besides the Quality System Certifications, WALWORTH has achieved the following specific product certifications:**



- TA Luft Certificate (Fugitive Emission) Approval ISO-5211 Top Flange, Anti-Static Device.



- Certificates of Ultra Low Fugitive Emissions No. 20985-3, 8 & 16 in accordance with ISO-15848-1 "Industrial Valves"-Measurement, Test and Qualification Procedures for Fugitive Emissions" "Part 1: Classification System and Qualification Procedures for Type Testing of Valves".

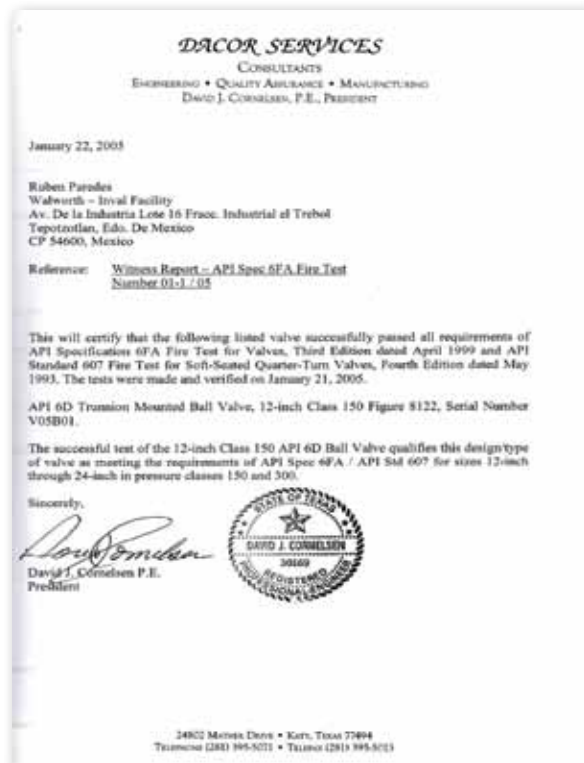

- Fire Test Certificate No. 04/04 in accordance with API-6FA and API Standard API-607 for Trunnion Ball Valves in accordance with API-6D.



- Emissions after 500 cycles at ambient and 350 °F issued by Yarmouth Research and Technology Lab. After 500 cycles the measurement result was less than 50 ppm.

### FUGITIVE EMISSION TEST CERTIFICATE

Name of Manufacturer: <b>Walworth</b>	
Description of Valve: <b>3 inch Class 300 Gate Valve</b>	
2506F with Ultra Low Emission Packing	
Test Specification: <b>ISO 15848-1 (2006) - Industrial valves — Measurement, test and qualification procedures for fugitive emissions. Part 1: Classification system and qualification procedures for type testing of valves</b>	
Test Parameters: <b>Endurance Class   CO<sub>2</sub> - 500 Cycles</b>	<b>Performance Class   B1</b>
<b>Temperature Classes   Ambient, 200C, 400C, -20C</b>	<b>Pressure Class   ANSI 300</b>
Test Date: <b>August 2009</b>	Certificate Number: <b>120945-1</b>

**RESULTS**

The packing qualifies to Class B leakage levels with no readings above 3.8 e-5 atm cc/sec throughout the tests.

*This certificate refers to the above mentioned product for the test conducted. This certificate does not imply assessment of the production of the product and future performance.*

**Laboratory Information**

Name:	<b>Yarmouth Research and Technology</b>
Address:	<b>434 Walnut Hill Road North Yarmouth, ME 04097 USA</b>
Tester:	<b>Matthew Wasielewski, PE info@yarmouthresearch.com www.yarmouthresearch.com (207) 829-5359</b>



### FUGITIVE EMISSION TEST CERTIFICATE

Name of Manufacturer: <b>Walworth</b>	
Description of Valve: <b>4 inch Class 300 Gate Valve</b>	
2506F with Ultra Low Emission Packing	
Test Specification: <b>ISO 15848-1 (2006) - Industrial valves — Measurement, test and qualification procedures for fugitive emissions. Part 1: Classification system and qualification procedures for type testing of valves</b>	
Test Parameters: <b>Endurance Class   CO<sub>2</sub> - 500 Cycles</b>	<b>Performance Class   B1</b>
<b>Temperature Classes   Ambient, 200C, 400C, -20C</b>	<b>Pressure Class   ANSI 300</b>
Test Date: <b>August 2009</b>	Certificate Number: <b>120945-8</b>

**RESULTS**

The packing qualifies to Class B leakage levels with no readings above 6.1 e-5 atm cc/sec throughout the tests.

*This certificate refers to the above mentioned product for the test conducted. This certificate does not imply assessment of the production of the product and future performance.*

**Laboratory Information**

Name:	<b>Yarmouth Research and Technology</b>
Address:	<b>434 Walnut Hill Road North Yarmouth, ME 04097 USA</b>
Tester:	<b>Matthew Wasielewski, PE info@yarmouthresearch.com www.yarmouthresearch.com (207) 829-5359</b>



### FUGITIVE EMISSION TEST CERTIFICATE

Name of Manufacturer: <b>Walworth</b>	
Description of Valve: <b>16 inch Class 150 Gate Valve</b>	
2506F with Ultra Low Emission Packing	
Test Specification: <b>ISO 15848-1 (2006) - Industrial valves — Measurement, test and qualification procedures for fugitive emissions. Part 1: Classification system and qualification procedures for type testing of valves</b>	
Test Parameters: <b>Endurance Class   CO<sub>2</sub> - 500 Cycles</b>	<b>Performance Class   B1</b>
<b>Temperature Classes   Ambient, 200C, 400C, -20C</b>	<b>Pressure Class   ANSI 150</b>
Test Date: <b>August-September 2009</b>	Certificate Number: <b>120985-16</b>

**RESULTS**

The packing qualifies to Class B leakage levels with no readings above 7.8 e-5 atm cc/sec throughout the tests.

*This certificate refers to the above mentioned product for the test conducted. This certificate does not imply assessment of the production of the product and future performance.*

**Laboratory Information**

Name:	<b>Yarmouth Research and Technology</b>
Address:	<b>434 Walnut Hill Road North Yarmouth, ME 04097 USA</b>
Tester:	<b>Matthew Wasielewski, PE info@yarmouthresearch.com www.yarmouthresearch.com (207) 829-5359</b>





# QUALITY CONTROL EQUIPMENT

In order to assure that **WALWORTH** products comply with quality international standards, in-house equipments are kept for monitoring control, some of this equipment includes:



**X-Ray Examination Equipment.** **WALWORTH** has its own Ir-92 source in-house for the radiographic examination (RT) of castings from 0.100" up to 2 1/2" wall thickness to verify the soundness of the casting raw material.

**PMI Equipment.** - New generation of Positive Material Identification Equipment gives **WALWORTH** the capability to perform quick chemical analysis on incoming raw materials and on pieces after assembly to certify that materials used were produced and assembled in accordance with **WALWORTH** and the Customer's specifications.



**Magnetic Particle Test.** - In a random basis for standard products or when a Customer request MT Certification, **WALWORTH** has Magnetic Particle Test Equipment to perform on ferromagnetic materials.

**Penetrant Test Examination.** - **WALWORTH** has the personnel and materials to perform PT examination by solvent removable or water washable techniques. The NDT personnel are ASNT Certified.



**Test Loop.** - A complete Laboratory Test loop exists for design validation of **WALWORTH** products performing the test at maximum design pressure and cycling the valves from 3000 to 5000 cycles. The test expends more than 4 months to be finished.

**Pressure Gradient Test Loop.** - This test exposes Plug valves to the extremes of both positive and negative pressure gradients to verify that the plug in a balanced plug design will prevent lock-up into the body.





**Metrology Laboratory.-** WALWORTH developed a calibration and / or verification system in all the equipment used in its facilities to ensure the traceability of measurements to international standards. In this way, **WALWORTH** gets measurement control of its products to comply with international standards.

**Fire Test Facilities.-** Facilities to perform fire test in accordance to API requirements. The test exposes the valve to a fire flame at 1400 to 1800 °F (761 to 980 °C) to verify proper seal of the valve.



**Low Fugitive Emissions Test.-** When a Customer requires low fugitive emissions certification. The Lab has its own LFE Test Equipment capable to measure less than 20 ppm either in both static or Mechanical conditions at ambient temperature or thermal cycle operations.

**Ultrasonic Testing Equipment.-** Using ultrasonic techniques, we can detect sub surface flaws in materials and evaluate castings and forgings that cannot be radiographed. In addition we utilize these techniques to measure the wall thickness of castings and forgings.



**Tensile Test Equipment.-** To verify the mechanical properties of materials used for manufacturing, **WALWORTH** tests samples on a random basis even though we receive MTR's from our suppliers and foundries.

**Hardness Test Equipments.-** We utilize hardness testing equipment to verify hardness of raw material and finished product components.



# CAST STEEL GATE, GLOBE AND CHECK VALVES

## CARBON STEEL; ALLOY STEEL; STAINLESS STEEL & EXOTIC ALLOY VALVES

This is the primary WALWORTH product line, manufactured in accordance with ANSI classes 150, 300, 600, 900, 1500 & 2500 # and sizes from 2" up to 72" nominal diameter, provides the end user a wide variety of valves to satisfy their needs. WALWORTH always keeps these valves in stock in the most common trims used in the industries. This product line is manufactured as per API-600 design requirements for gate valves; ASME B16.34 for globe valves and ASME B16.34 & API-6D for swing check valves.

One of the most important features of WALWORTH Cast Steel Valves is its guarantee to meet and exceed 50 ppm maximum low fugitive emissions leakage rate as furnished "off the shell" without a Customer's special order requirement.

WALWORTH valves were tested in accordance with API-591 RP and approved.

WALWORTH offers the majority of materials known and used for this product line, including but not limited to:

- a) Carbon Steel like WCA, WCB, WCC, etc.
- b) Low Carbon Steel like LCB, LCC, etc.
- c) Low Alloy Steel like WC1, WC5, WC6, WC9, etc.
- d) Low Carbon Low Alloy Steel like LC2, LC3, etc.
- e) Medium Alloy Steel like C5, C12, C12A, etc.
- f) Stainless Steel like CF8, CF8M, CF8C, CF10, CG8M, etc.
- g) Low Carbon Stainless Steel like CF3, CF3M, CG3M, etc.
- h) Super Stainless Steel like CN7M(Alloy 20), CN3M (Alloy 20 modified), CT15C, etc.
- i) Duplex Stainless Steel like CE8MN, CD6MN, CD3MN, etc.
- j) High Nickel Alloys like Monel M30C, Monel M35-1, Monel CZ100, Inconel CY40 (Inconel 600), CW2M (Hastelloy C4), N12MV (Hastelloy B), CW12MW (Former Hastelloy C-276), CW6M (New Hastelloy C-276), CU5MCuC (Incoloy 825), N7M (Hastelloy B2), CW6MC (Incoloy 625), etc.
- k) Super Duplex Stainless Steel like CE3MN, CD3MNCuN, etc.
- l) Aluminum Bronze like 95500, 95600, 95800, etc.

TYPE	SIZE	PRESSURE CLASS AS PER ASME B16.34	ENDS
Gate	2" to 72"	150, 300, 600, 900, 1500 & 2500 #	RF, RTJ or BW
Globe	2" to 20"	150, 300, 600, 900, 1500 & 2500 #	RF, RTJ or BW
Swing Check	2" to 48"	150, 300, 600, 900, 1500 & 2500 #	RF, RTJ or BW



# CAST STEEL BOLTED BONNET VALVES BODY MATERIALS

Walworth® offers the standard product line of API 600 Cast Steel valves in a wide variety of carbon steel, low and medium allow materials, that can be used in combination with listed API-600 trims.

However, due to the actual requirements that the global market demands, Walworth® offers now additional materials like stainless steel, nickel and exotic alloys using the heavy wall thickness patterns to meet those end user requirements which does not accept the light pattern design as per API-603.

Also, Walworth® offers a new product line for valves with heavy wall thickness in Aluminum Bronze, either ASTM B148 grade 95500, 95600 or 95800.

\* For those valves where light pattern design API-603 is accepted, please ask for our API-603 Walworth® catalog.

MATERIAL SUFFIX	COMMON DESIGNATION	FORGING SPECIFICATION	WROUGHT BAR SPECIFICATION	SERVICE RECOMMENDATIONS (1)	COMMON TRIM FOR THIS BASE MATERIAL	
					150 TO 600 #	900 TO 2500 #
ASTM A216 Grade WCB	Carbon Steel	A105	A105	Non-corrosive applications including water, oil and gases at temperatures between -20°F (-30°F) and +800°F (+425°C)	UT, 3HF, A	HF, 3HF+HF
ASTM A216 Grade WCC	Carbon Steel	A105N	A105N	Non-corrosive applications including water, oil and gases at temperatures between -20°F (-30°F) and +800°F (+425°C)	UT, 3HF, A	HF, 3HF+HF
ASTM A352 Grade LCB	Low Temp Carbon steel	A350 LF1	A350 LF1	Low temperature applications to -50 °F (-46°C).Not for use above + 650°F(+340°C).	UT, 3HF, A	HF, 3HF+HF
ASTM A352 Grade LCC	Low Temp Carbon steel	A350 LF2	A350 LF2	Low temperature applications to -50 °F (-46°C).Not for use above + 650°F(+340°C).	UT, 3HF, A	HF, 3HF+HF
ASTM A352 Grade LC3	3 1/2 % Nickel Steel	A350 LF3	A350 LF3	Low temperature applications to - 150°F (-101°C). Not for use above + 650°F(+340°C).	UT, 3HF, A	HF, 3HF+HF
ASTM A217 Grade WC1	C-1/2 Mo Low Alloy Steel	A182 F1	A182 F1	Non-corrosive applications including water, oil and gases at temperatures between -20°F (-30°C) and + 1100°F(+593°C).	UT, 3HF, A	HF, 3HF+HF
ASTM A217 Grade WC5	0.75% Ni; Mo; 0.75% Cr Low Alloy Steel	A182 F2	A182 F2	Non-corrosive applications including water, oil and gases at temperatures between -20°F (-30°C) and + 1100°F(+593°C).	UT, 3HF, A	HF, 3HF+HF
ASTM A217 Grade WC6	1 1/4% Chrome; 1/2% Moly Low Alloy Steel	A182 F11	A182 F11 Class 2	Non-corrosive applications including water, oil and gases at temperatures between -20°F (-30°C) and + 1100°F(+593°C).	UT, 3HF, A	HF, 3HF+HF
ASTM A217 Grade WC9	2 1/4 % Chrome Low Alloy Steel	A182 F22	A182 F11 Class 3	Non-corrosive applications including water, oil and gases at temperatures between -20°F (-30°C) and + 1100°F(+593°C).	UT, 3HF, A	HF, 3HF+HF
ASTM A217 Grade C5	5% Chrome; 1/2 % Moly, Medium Alloy Steel	A182 F5	A182 F5	Mild corrosive or erosive applications as well as non-corrosive applications at temperatures between- 20°F (-30°C) and + 1200°F (+649°C).	UT, 3HF, A	HF, 3HF+HF
ASTM A217 Grade C12	9% Chrome; 1% Moly, Medium Alloy Steel	A182 F9	A182 F9	Mild corrosive or erosive applications as well as non-corrosive applications at temperatures between- 20°F (-30°C) and + 1200°F (+649°C).	UT, 3HF, A	HF, 3HF+HF

# CAST STEEL BOLTED BONNET VALVES BODY MATERIALS

MATERIAL SUFFIX	COMMON DESIGNATION	FORGING SPECIFICATION	WROUGHT BAR SPECIFICATION	SERVICE RECOMMENDATIONS (1)	COMMON TRIM FOR THIS BASE MATERIAL	
					150 TO 600 #	900 TO 2500 #
ASTM A217 Grade C12-A	9% Chrome; 1% Moly; V-N, Medium Alloy Steel	A182 F91	A182 F91	Mild corrosive or erosive applications as well as non-corrosive applications at temperatures between -20°F (-30°C) and +1200°F (+649°C).	UT, 3HF, A	HF, 3HF+HF
ASTM A351 Grade CF8	18% Chrome; 8% Nickel; 0.08 % C Stainless Steel	ASTM A182 F304	ASTM A479 304	Corrosive or extremely high temperature non-corrosive services between -450°F (-268°C) and +1200°F (+649°C). Above +800°F (+425°C) specify carbon content of 0.04% or greater.	2, 4HF	4HF+HF
ASTM A351 Grade CF8M	18% Chrome; 12% Nickel; 2 % Mo; 0.08 % C Stainless Steel	ASTM A182 F316	ASTM A479 316	Corrosive or either extremely low or high temperature non-corrosive services between -450°F (-268°C) and +1200°F (+649°C). Above +800°F (+425°C) specify carbon content of 0.04% or greater.	18-8smo, 3HF	3HF+HF
ASTM A351 Grade CF3	18% Chrome; 8% Nickel; 0.03 % C Low Carbon Stainless Steel	ASTM A182 304L	ASTM A479 304L	Brackish water, phosphate solutions, pressurized water @ 570 °F (299 °C), sea water, steam.	304L, 3HF	304L, 3HF+HF
ASTM A351 Grade CF3M	18% Chrome; 12% Nickel; 2 % Mo; 0.03 % C Low Carbon Stainless Steel	ASTM A182 F316L	ASTM A479 316L	Acetic acid, calcium carbonate, calcium lactate, potable water, sea water, steam, sulfites.	316L, 3HF	316L, 3HF+HF
ASTM A351 Grade CG3M	18% Chrome; 12% Nickel; 3 % Mo; 0.03 % C Low Carbon Stainless Steel	ASTM A182 F317L	ASTM A182 F317L	Corrosive or non corrosive services to +800°F (+425°C)*	317L, 317LH	317L, 317LH
ASTM A351 Grade CF8C	18% Chrome; 10% Nickel; Cb; 0.08 % C Stainless Steel	ASTM A182 F347	ASTM A479 347	Primarily for high temperature, corrosive applications between -450°F (-268°C) and +1200°F (+649°C). Above +1000°F (+540°C) specify carbon content of 0.04% or greater. Hydrogen service.*	347H, 347HF	347H, 347HF
ASTM A351 Grade CF10	18% Chrome; 8% Nickel; 0.08 % C Stainless Steel	ASTM A182 F304H	ASTM A479 304H	Corrosive or extremely high temperature non-corrosive services between -450°F (-268°C) and +1200°F (+649°C). Above +800°F (+425°C) specify carbon content of 0.04% or greater.	310, 310HF	310HF
ASTM A351 Grade CF10M	18% Chrome; 8% Nickel; 2% Mo; 0.08 % C Stainless Steel	ASTM A182 F316H	ASTM A479 316H	Corrosive or extremely high temperature non-corrosive services between -450°F (-268°C) and +1200°F (+649°C). Above +800°F (+425°C) specify carbon content of 0.04% or greater.	310, 310HF	310HF
ASTM A351 Grade CG8M	18% Chrome; 10% Nickel; 3 % Mo; 0.08 % C Stainless Steel	ASTM A182 F317	ASTM A182 F317	Heavy water manufacturing, Nuclear, Petroleum, Pipe Line, Power, Pulp and paper, Printing Textile, Corrosive dye solutions, ink, sulfite liquor.	317H, 21HF	317H, 21HF
ASTM A351 Grade CK20	25% Chrome; 20% Nickel; 0.04 To 0.2 % C Super Stainless Steel	ASTM A182 F310H	ASTM A182 F310H	Aircraft, Chemical processing, Oil Refining, Pulp and Paper. Corrosives Hot products around 1200 °F (649 °C), sulfite liquor, sulfuric acid (dilute).	310, 310HF	310HF
ASTM A351 Grade CN7M	19% Chrome; 28% Nickel; Cu-Mo; 0.07 % C Super Stainless Steel	ASTM B462 N08020	ASTM B473 N08020	Acetic acid (hot), brines, caustic solutions, (strong, hot), hydrochloric acid (dilute), hydrofluoric acid and hydrofluosilicic acid (dilute), nitric acid, (strong, hot), nitric-hydrofluoric pickling acids, sulfates and sulfites, sulfuric acid, (all concentrations to 150 °F (65.6 °C)), sulfuric acid, phosphoric acid.	A20, A20H	A20, A20H
ASTM A351 Grade CN3MN	19% Chrome; 28% Nickel; Cu-Mo; 0.03 % C Super Stainless Steel	ASTM B462 N08020	ASTM B473 N08020	Acetic acid (hot), brines, caustic solutions, (strong, hot), hydrochloric acid (dilute), hydrofluoric acid and hydrofluosilicic acid (dilute), nitric acid, (strong, hot), nitric-hydrofluoric pickling acids, sulfates and sulfites, sulfuric acid, (all concentrations to 150 °F (65.6 °C)), sulfuric acid, phosphoric acid. Better weldability properties than CN7M	A20, A20H	A20, A20H
ASTM A351 Grade CK3MCuN	20% Chrome; 18% Nickel; 6% Mo; 0.25 % C Super Stainless Steel	ASTM A182 F44	ASTM A479 S31254	Acetic Acid, antibiotics and drugs, bleaching compounds, formic acid, fruit and juices, hot air, hot water, hydrocarbons, hydrochloric acid, organic liquids and acids, nitric acid, organic salts, oxalic acid, phosphoric acid, sea water, sewage, sodium bisulfite, steam, sulfamic acid, 10 % sulfuric acid,	254HF	254HF
ASTM A351 Grade CT15C	19% Chrome; 32% Nickel; 0.05 to 0.15 % C Incoloy 800.	ASTM B564 N08810	ASTM B408 N08810		810T	810T

# CAST STEEL BOLTED BONNET VALVES BODY MATERIALS

MATERIAL SUFFIX	COMMON DESIGNATION	FORGING SPECIFICATION	WROUGHT BAR SPECIFICATION	SERVICE RECOMMENDATIONS (1)	COMMON TRIM FOR THIS BASE MATERIAL	
					150 TO 600 #	900 TO 2500 #
ASTM A351 Grade CD4MCu	25.5% Chrome; 5.5% Nickel; 2% Mo; 0.040% C Super Stainless Steel	N/A	ASTM A479 S32550	Concentrate brine, fatty acids, potable water, pulp water, pulp liquors at 220 °F (104 °C), sea water, stem, sulfuric acid (15-30% @ 140-160 °F (60-71 °C), sulfuric acid (35-40 % @185 °F (85 °C), plus 5 % organics).	32250H	32250H
ASTM A351 Grade CN2MCuN	21% Chrome; 25.5% Nickel; 4.5% Mo; 1.5%Cu; 0.02% C Super Stainless Steel	ASTM B469 8904	ASTM B625 8904		8904H	8904H
ASTM A487 Grade CA15	12% Chrome Steel	ASTM A182 F6	ASTM A276 410	Corrosive application at temperatures between -20°F (-30°C) and + 900°F (+482°C).	UT, HF	UT, HF
ASTM A487 Grade CA6NM	12% Chrome Steel	ASTM A182 F6	ASTM A276 410	Corrosive application at temperatures up to +1300°F (704°C). Boiler feed water 250 °F (115°C), sea water, steam sulfur.	UT, HF	UT, HF
ASTM A494 Grade M-35-1	67% Ni; 30% Cu, Monel	ASTM B564 N04400	ASTM B164 N04400	Weldable grade. Good resistance to corrosion by all common organic acids and salt water. Also highly resistant to most alkaline solutions to +7W°F (+400°C)	A, AHF	A, AHF
ASTM A494 Grade CZ100	95% Nickel	ASTM B160 N02200	ASTM B160 N02200	Chemical processing, mineral processing, food processing. NiCl is useful in handling hot concentrate alkaline or caustic solutions, reducing acids, certain food products, organic acids under certain conditions, dry chlorine and anhydrous ammonia. Cast nickel is not applicable in oxidizing acids and alkaline perchlorite.	2200	2200
ASTM A494 Grade CY-40	75% Nickel; 15% Cr; 8% Fe, Inconel 600	ASTM B564 N06600	ASTM B166 N06600	Very good for high temperature service. Good resistance to strongly corrosive media and atmosphere to + 800°F (+425°C). Hot boiler feed water, hot caustics, hot concentrate alk water, elevated temperature oxidizing conditions.	600, 600HF	600, 600HF
ASTM A494 Grade CW6MC	60% Nickel; 22% Cr; 9% Mo; 3.5% Cb, Inconel 625	ASTM B564 N06625	ASTM B446 N06625	Very good for high temperature service. Good resistance to strongly corrosive media and atmosphere to + 800°F (+425°C).	625, 625HF	625, 625HF
ASTM A494 Grade CU5MCuC	42% Nickel; 21.5% Cr; 3% Mo; 2.3% Cu, Incoloy 825	ASTM B425 N08825	ASTM B425 N08825		825, 23HF	825, 23HF
ASTM A494 Grade N12MV	62% Nickel; 28% Mo; 5% Fe, Hastelloy B	ASTM B335 N10001	ASTM B335 N10001		10001, HB	10001, HB
ASTM A494 Grade N7M	62% Nickel; 28% Mo; 2% Fe, Hastelloy B2	ASTM B335 N10665	ASTM B335 N10665		HB	HB
ASTM A494 Grade CW2M	61% Nickel; 16% Mo; 16% Cr, Hastelloy C4	ASTM B574 N06455	ASTM B574 N06455	Good resistance to strong oxidation conditions. Good properties at high temperatures, high resistance to formic, phosphoric, sulphurous and sulfuric acids to + 1200°F (+649°C)	6455H	6455H
ASTM A494 Grade CW12MW	56% Nickel; 18% Mo; 17% Cr; 6% Fe, Hastelloy C-276 (FORMER ALLOY)	ASTM B574 N10276	ASTM B574 N10276	Good resistance to strong oxidation conditions. Good properties at high temperatures, high resistance to formic, phosphoric, sulphurous and sulfuric acids to + 1200°F (+649°C)	HC, HCH	HC, HCH
ASTM A494 Grade CW6MC	56% Nickel; 19% Mo; 18% Cr; 16% Fe, Hastelloy C-276 (NEW ALLOY)	ASTM B574 N10276	ASTM B574 N10276	Good resistance to strong oxidation conditions. Good properties at high temperatures, high resistance to formic, phosphoric, sulphurous and sulfuric acids to + 1200°F (+649°C)	HC, HCH	HC, HCH

# CAST STEEL BOLTED BONNET VALVES BODY MATERIALS

MATERIAL SUFFIX	COMMON DESIGNATION	FORGING SPECIFICATION	WROUGHT BAR SPECIFICATION	SERVICE RECOMMENDATIONS (1)	COMMON TRIM FOR THIS BASE MATERIAL	
					150 TO 600 #	900 TO 2500 #
ASTM A995 Grade CD4MCu	25.5% Chrome; 5.5% Nickel; 2% Mo; 0.040% C Duplex Stainless Steel Grade 1A.	N/A	ASTM A479 S32550	Concentrate brine, fatty acids, potable water, pulp water, pulp liquors at 220 °F (104 °C), sea water, stem, sulfuric acid (15-30% @ 140-160 °F (60-71 °C), sulfuric acid (35-40 % @185 °F (85 °C), plus 5 % organics).	32250H	32250H
ASTM A995 Grade CE8MN	24% Chrome; 9.5% Nickel; 4% Mo; 0.080% C Duplex Stainless Steel Grade 2A.	ASTM A182 F51	ASTM A479 32750	Concentrate brine, fatty acids, potable water, pulp water, pulp liquors at 220 °F (104 °C), sea water, stem, sulfuric acid (15-30% @ 140-160 °F (60-71 °C), sulfuric acid (35-40 % @185 °F (85 °C), plus 5 % organics).	32750H, 31803H, 51H	32750H, 31803H, 51H
ASTM A995 Grade CD3MN	22% Chrome; 5% Nickel; 3% Mo; N; 0.030% C Duplex Stainless Steel Grade 4A.	ASTM A182 F51	ASTM A479 31803	Concentrate brine, fatty acids, potable water, pulp water, pulp liquors at 220 °F (104 °C), sea water, stem, sulfuric acid (15-30% @ 140-160 °F (60-71 °C), sulfuric acid (35-40 % @185 °F (85 °C), plus 5 % organics).	32750H, 31803H, 51H	32750H, 31803H, 51H
ASTM A995 Grade CeE3MN	25% Chrome; 7% Nickel; 4.5% Mo; N; 0.030% C Duplex Stainless Steel Grade 5A.	ASTM A182 F53	ASTM A182 F53	Concentrate brine, fatty acids, potable water, pulp water, pulp liquors at 220 °F (104 °C), sea water, stem, sulfuric acid (15-30% @ 140-160 °F (60-71 °C), sulfuric acid (35-40 % @185 °F (85 °C), plus 5 % organics). Useful where the Pitting Resistance Number (PREN) is required.	53H, 53HF	53H, 53HF
ASTM A995 Grade CD3MWCuN	25% Chrome; 7.5% Nickel; 3.5% Mo; N; 0.030% C Duplex Stainless Steel Grade 6A.	ASTM A182 F53	ASTM A182 F53	Concentrate brine, fatty acids, potable water, pulp water, pulp liquors at 220 °F (104 °C), sea water, stem, sulfuric acid (15-30% @ 140-160 °F (60-71 °C), sulfuric acid (35-40 % @185 °F (85 °C), plus 5 % organics). Useful where the Pitting Resistance Number (PREN) is required.	53H, 53HF	53H, 53HF
ASTM B148 Grade 95800	79% min Copper; 4.5% Nickel; 9% Aluminum; 3-4.5% Fe; 0.03 % max Pb.	N/A	ASTM C63000	Sea water service.	BCE630	BCE630

(1) The above list of consuming industries and corrosive materials are useful as examples of typical applications where these materials can be used where they can be used as a guide; however, the responsibility to choose the proper alloy is from the Engineering firm or End User.

## NOMENCLATURE

TYPE	CLASS
ST6	STELLITE 6
13%Cr	STAINLESS STEEL 410
316	STAINLESS STEEL 316
304	STAINLESS STEEL 304
HC	HASTELLOY "C"
CN7M	CHROME-NICKEL STEEL
321	STAINLESS STEEL 321
ST21	STELLITE 21
A20	STAINLESS STEEL ALLOY 20
347	STAINLESS STEEL 347
321	STAINLESS STEEL 321
8810	STAINLESS STEEL 8810
625	INCONEL 625
410 T	STAINLESS 410 (HARDNESS 200-275 BHN)

TYPE	CLASS
316L	STAINLESS STEEL 316L
HB	HASTELLOY "B"
317L	STAINLESS STEEL 317L
17 4PH	STAINLESS STEEL 17 4PH
317	STAINLESS STEEL 317
825	INCOLOY 825
304L	STAINLESS STEEL 304L
K500	MONEL K500
31803	STAINLESS STEEL 31803
718	INCONEL 718
8367	STAINLESS STEEL 8367
TC	TUNGSTEN CARBIDE
W1	WALWELD-100
NUC	NUCALLOY

# WALWORTH CAST STEEL VALVES TRIM ARRANGEMENTS

Walworth® valves are available in the widest range of standard and special trims available in the Industry. The following table shows the most popular trims used for the valves offered these days by the Company.

Special trims as per Customer requirements are available upon request. Please contact your closest Walworth® Distributor.

WALWORTH TRIM Nr.	API-600 TRIM Nr.	SEAL MATERIAL TYPE	STEM AND OTHER TRIM PARTS (1)	WEDGE/DISC SEAT SURFACES	BODY SEAT SURFACES (2)
AA	1	13Cr-0.75Ni-1Mn	SS-410 (200-275 HBN)	SS-410 (200 HBN)	SS-410 (250 HBN min)
18-8	2	19Cr-9.5Ni-2Mn-0.08C	SS-304	SS-304	SS-304
310	3	25Cr-20.5Ni-2Mn	SS-310	SS-310	SS-310
N/A	4	13Cr-0.75Ni-1Mn	SS-410 (200-275 HBN)	SS-410 (200-275 HBN)	SS-410 (275 HBN min)
HF	5 OR 5A	13Cr-0.5Ni-1Mn/Co-Cr-A	SS-410(200-275 HBN)	Stellite 6 (350 HBN min)	Stellite 6 (350 HBN min)
AAA	6	13Cr-0.5Ni-1Mn/Ni-Cu	SS-410(200-275 HBN)	SS-410(250 HBN min)	Monel 400 (175 HBN min)
N/A	7	13Cr-0.5Ni-1Mo/13Cr-0.5Ni-1Mo	SS-410(200-275 HBN)	SS-410(250 HBN min)	SS-410(750 HBN min)
UT	8 OR 8A	13Cr-0.75Ni-1Mn/1/2Co-Cr-A	SS-410 (200-275 HBN)	SS-410 (250 HBN min)	Stellite 6 (350 HBN min)
A	9	70Ni-30Cu	UN N04400 (Monel 400)	UN N04400 (Monel 400)	UN N04400 (Monel 400)
18-8smo	10	18Cr-12Ni-2.5Mo-2Mn	SS-316	SS-316	SS-316
AHF	11 OR 11A	70Ni-30Cu/1/2Co-Cr-A	UN N04400 (Monel 400)	UN N04400 (Monel 400)	Stellite 6 (350 HBN min)
3HF	12 OR 12A	18Cr-12Ni-2.5Mo-2Mn/1/2Co-Cr-A	SS-316	SS-316	Stellite 6 (350 HBN min)
A20	13	29Ni-19Cr-2.5Mo-0.07C	UNS N08020 (Alloy 20)	UNS N08020 (Alloy 20)	UNS N08020 (Alloy 20)
A20H	14 OR 14A	29Ni-19Cr-2.5Mo-0.07C/1/2Co-Cr-A	UNS N08020 (Alloy 20)	UNS N08020 (Alloy 20)	Stellite 6 (350 HBN min)
NUC	NOT SPECIFIED	13Cr-0.5Ni-1Mn/NUCALLOY	SS-410(200-275 HBN)	NUCALLOY	NUCALLOY
4HF	NOT SPECIFIED	19Cr-9.5Ni-2Mn-0.08C/1/2Co-Cr-A	SS-304	SS-304	Stellite 6 (350 HBN min)
4HF+HF	NOT SPECIFIED	19Cr-9.5Ni-2Mn-0.08C/Co-Cr-A	SS-304	Stellite 6 (350 HBN min)	Stellite 6 (350 HBN min)
304L	NOT SPECIFIED	19Cr-9.5Ni-2Mn-0.03C	SS-304L	SS-304L	SS-304L
1HF	NOT SPECIFIED	18Cr-12Ni-2.5Mo-2Mn/Co-Cr-Mo	SS-316	Stellite 21 (320 HBN min)	Stellite 21 (320 HBN min)
3HF+HF	NOT SPECIFIED	18Cr-12Ni-2.5Mo-2Mn/Co-Cr-A	SS-316	Stellite 6 (350 HBN min)	Stellite 6 (350 HBN min)
3TC (3)	NOT SPECIFIED	18Cr-8Ni-Mo/TgC	SS-316/Tungsten carbide	Tungsten Carbide	Stellite 6 (350 HBN min)
316L	NOT SPECIFIED	17Cr-12Ni-2.5Mo-2Mn0.03C	SS-316L	SS-316L	SS-316L
3LHF	NOT SPECIFIED	17Cr-12Ni-2.5Mo-2Mn0.03C/1/2Co-Cr-A	SS-316L	SS-316L	Stellite 6 (350 HBN min)
3HFL	NOT SPECIFIED	17Cr-12Ni-2.5Mo-2Mn0.03C/Co-Cr-A	SS-316L	Stellite 6 (350 HBN min)	Stellite 6 (350 HBN min)
21HF	NOT SPECIFIED	19Cr-11.5Ni-3.5Mo/Co-Cr-A	SS-317	Stellite 6 (350 HBN min)	Stellite 6 (350 HBN min)
317	NOT SPECIFIED	19Cr-11.5Ni-3.5Mo	SS-317	SS-317	SS-317



# WALWORTH CAST STEEL VALVES TRIM ARRANGEMENTS

WALWORTH TRIM Nr.	API-600 TRIM Nr.	SEAL MATERIAL TYPE	STEM AND OTHER TRIM PARTS (1)	WEDGE/DISC SEAT SURFACES	BODY SEAT SURFACES (2)
317H	NOT SPECIFIED	19Cr-11.5Ni-3.5Mo/1/2Co-Cr-A	SS-317	SS-317	Stellite 6 (350 HBN min)
317LH	NOT SPECIFIED	19Cr-13Ni-3.5Mo/Co-Cr-A	SS-317L	Stellite 6 (350 HBN min)	Stellite 6 (350 HBN min)
317L	NOT SPECIFIED	19Cr-13Ni-3.5Mo-0.03C	SS-317L	SS-317L	SS-317L
317LS	NOT SPECIFIED	19Cr-13Ni-3.5Mo/1/2Co-Cr-A	SS-317L	SS-317L	Stellite 6 (350 HBN min)
2HF	NOT SPECIFIED	18Cr-10Ni-0.1N/Co-Cr-A	SS-321	SS-321	Stellite 6 (350 HBN min)
321F	NOT SPECIFIED	18.5Cr-11Ni-2Mn/Co-Cr-A	SS-321	Stellite 6 (350 HBN min)	Stellite 6 (350 HBN min)
321	NOT SPECIFIED	19Cr-11.5Ni-3.5Mo	SS-321	SS-321	SS-321
347HF	NOT SPECIFIED	18.5Cr-11Ni-2Mn-Co/Co-Cr-A	SS-347	Stellite 6 (350 HBN min)	Stellite 6 (350 HBN min)
347	NOT SPECIFIED	18.5Cr-11Ni-2Mn-Co	SS-347	SS-347	SS-347
347H	NOT SPECIFIED	18.5Cr-11Ni-2Mn-Co/1/2Co-Cr-A	SS-347	SS-347	Stellite 6 (350 HBN min)
254HF	NOT SPECIFIED	20Cr-18Ni-6.2Mo-0.02C-Cu+N	UNS S31254	Stellite 6 (350 HBN min)	Stellite 6 (350 HBN min)
51H	NOT SPECIFIED	22Cr-5.5Ni-3Mo-N-0.03C/Co-Cr-A	UNS S31803	Stellite 6 (350 HBN min)	Stellite 6 (350 HBN min)
31803H	NOT SPECIFIED	22Cr-5.5Ni-3Mo-N-0.03C/Co-Cr-A	UNS S31803	UNS S31803	Stellite 6 (350 HBN min)
T9	NOT SPECIFIED	16Cr-4Ni-4Cu-Nb+Ta/Co-Cr	17-4pH	Triballoy 900	Triballoy 900
HC	NOT SPECIFIED	55Ni-15.5Cr-16Mo-3Tg-4Fe	Hastelloy C-276	Hastelloy C-276	Hastelloy C-276
HCH	NOT SPECIFIED	55Ni-15.5Cr-16Mo-3Tg-4Fe/1/2Co-Cr-A	Hastelloy C-276	Hastelloy C-276	Stellite 6 (350 HBN min)
UOP	NOT SPECIFIED	63Ni-30Cu-Al+Ti/70Ni-30Cu	UN N05500 (Monel K-500)	UN N04400 (Monel 400)	UN N04400 (Monel 400)
625	NOT SPECIFIED	60Ni-22Cr-9Mo-3.5Cb	UNS N06625 (Incoloy 625)	UNS N06625 (Incoloy 625)	UNS N06625 (Incoloy 625)
625HF	NOT SPECIFIED	60Ni-22Cr-9Mo-3.5Cb/Co-Cr-A	UNS N06625 (Incoloy 625)	Stellite 6 (350 HBN min)	Stellite 6 (350 HBN min)
8367HF+HF	NOT SPECIFIED	25Ni-20Cr-6.5Mo-2Mn-0.03C/Co-Cr-A	UNS N08367 (AL6XN)	Stellite 6 (350 HBN min)	Stellite 6 (350 HBN min)
810T	NOT SPECIFIED	33Ni-21Cr-39.5Fe-1.5Mn	UNS N08810 (Incoloy 800H)	UNS N08810 (Incoloy 800H)	UNS N08810 (Incoloy 800H)
825	NOT SPECIFIED	42Ni-21.5Cr-3Mo-Ti+Al-0.05C	UNS N08825 (Incoloy 825)	UNS N08825 (Incoloy 825)	UNS N08825 (Incoloy 825)
23HF	NOT SPECIFIED	42Ni-21.5Cr-3Mo/CO-Cr-Mo	UNS N08825 (Incoloy 825)	Stellite 21 (320 HBN min)	Stellite 21 (320 HBN min)
HB	NOT SPECIFIED	66Ni-28Mo-1Mn-0.02C	UNS N10665 (Hastelloy B2)	UNS N10665 (Hastelloy B2)	UNS N10665 (Hastelloy B2)
BCE630	NOT SPECIFIED	79Cu-4.5Ni-9Al-4Fe-0.03Pb	ASTMB B150 63000	ASTMB B150 63000	ASTM B150 63000
HB	NOT SPECIFIED	66Ni-28Mo-1Mn-0.02C	UNS N10665 (Hastelloy B2)	UNS N10665 (Hastelloy B2)	UNS N10665 (Hastelloy B2)

## COMMON CONSTRUCTION MATERIALS COMBINATION

Following table shows the most common combination in between base material and trim. There are many other trims which can be combined with these base materials, please refer to other sections of this catalog for additional information.

DESCRIPTION	ASTM A216 WCB OR WCC TRIM UT (API-600 Nr. 8)	ASTM A217 WC6 TRIM UT (API-600 Nr. 8)	ASTM A217 WC9 TRIM UT (API-600 Nr. 8)	ASTM A217 C5 TRIM UT (API-600 Nr. 8)	ASTM A217 C12 TRIM UT (API-600 Nr. 8)	ASTM A352 LCB OR LCC TRIM UT (API-600 Nr. 8)
BODY	ASTM A 216 GR WCB/ WCC	ASTM A 217 GR WC6	ASTM A 217 GR WC9	ASTM A 217 GR C5	ASTM A 217 GR C12	ASTM A352 GR LCB/LCC
BONNET	ASTM A 216 GR WCB/ WCC	ASTM A 217 GR WC6	ASTM A 217 GR WC9	ASTM A 217 GR C5	ASTM A 217 GR C12	ASTM A352 GR LCB/LCC
WEDGE/SEATING	ASTM A 216 GR WCB/ WCC+13% Cr.	ASTM A 217 GR WC6 + 13% Cr.	ASTM A 217 GR WC9 + 13% Cr.	ASTM A 217 GR C5 + 13% Cr.	ASTM A 217 GR C12 + 13% Cr.	ASTM A 352 GR LCB/LCC + 13% Cr.
SEAT RINGS	ASTM A 515 GR 70 + ST 6	ASTM A 240 TYPE 410 + ST 6	ASTM A 240 TYPE 410 + ST 6	ASTM A 240 TYPE 410 + ST 6	ASTM A 240 TYPE 410 + ST 6	ASTM A 516 GR 65 + ST 6
STEM NUT	ASTM A 439 TYPE D2 OR ASTM B 148 UNS C95600	ASTM A 439 TYPE D2 OR ASTM B 148 UNS C95600	ASTM A 439 TYPE D2 OR ASTM B 148 UNS C95600	ASTM A 439 TYPE D2 OR ASTM B 148 UNS C95600	ASTM A 439 TYPE D2 OR ASTM B 148 UNS C95600	ASTM A 439 TYPE D2 OR ASTM B 148 UNS C95600
BONNET BUSHING	ASTM A 276 Type 410	ASTM A 276 Type 410	ASTM A 276 Type 410	ASTM A 276 Type 410	ASTM A 276 Type 410	ASTM A 276 Type 410
BONNET STUD	ASTM A 193 GR B7	ASTM A 193 GR B16	ASTM A 193 GR B16	ASTM A 193 GR B16	ASTM A 193 GR B16	ASTM A 193 GR L7
BONNET STUD NUT	ASTM A 194 GR 2H	ASTM A 194 GR 7	ASTM A 194 GR 7	ASTM A 194 GR 7	ASTM A 194 GR 7	ASTM A 194 GR 7
STEM PACKING	Graphite	Graphite	Graphite	Graphite	Graphite	Graphite
BONNET GASKET	Graphite/Stainless 316	Graphite/Stainless 316	Graphite/Stainless 316	Graphite/Stainless 316	Graphite/Stainless 316	Graphite/Stainless 316
HANDWHEEL	ASTM A 197	ASTM A 197	ASTM A 197	ASTM A 197	ASTM A 197	ASTM A 197
GEAR OPERATOR	As per WALWORTH design	As per WALWORTH design	As per WALWORTH design	As per WALWORTH design	As per WALWORTH design	As per WALWORTH design

## CHEMICAL COMPOSITION AND MECHANICAL PROPERTIES

Following table shows the nominal chemical composition and mechanical properties for the most common materials supplied. Additional information can be requested from your closest WALWORTH Distributor for other steel, stainless steels or Nickel alloys.

CHEMICAL COMPOSITION AND MECHANICAL PROPERTIES												
Elements and Properties	CARBON STEEL		LOW CARBON STEEL		LOW ALLOY STEEL		MEDIUM ALLOY STEEL		STAINLESS STEEL			
	ASTM A 216		ASTM A 352		ASTM A217				ASTM A351			
	WCB	WCC	LCB	LCC	WC6	WC9	C5	C12	CF8	CF8M	CF8C	
Carbon	0.30	0.25	0.30	0.25	0.05-0.20	0.05-0.18	0.20	0.20	0.08	0.08	0.08	
Manganese	1	1.2	1	1.2	0.50-0.80	0.40-0.70	0.40-0.70	0.35-0.65	1.5	1.5	1.5	
Phosphorus	0.04	0.04	0.04	0.04	0.04	0.04	0.04	0.04	0.04	0.04	0.04	
Sulphur	0.045	0.045	0.045	0.045	0.045	0.045	0.045	0.045	0.04	0.04	0.04	
Silicon	0.6	0.6	0.6	0.6	0.6	0.6	0.75	1	2	1.5	2	
Nickel	0.5	0.5	0.5	0.5	-	-	-	-	8.00-11.0	9.00-12.0	9.00-12.0	
Chromium	0.5	0.5	0.5	0.5	1.00-1.50	2.00-2.75	4.00-6.50	8.00-10.0	18.00-21.0	18.00-21.0	18.00-21.0	
Molybdenum	0.2	0.2	0.2	0.2	0.45-0.65	0.90-1.20	0.45-0.65	0.90-1.20	0.5	2.00-3.00	0.5	
Copper	0.3	0.3	0.3	0.3	0.5	0.5	0.5	0.5	-	-	-	
Columbium	-	-	-	-	-	-	-	-	-	-	(2)	
Vanadium	0.03	0.03	0.03	0.03	-	-	-	-	-	-	-	
Tensile Strength PSI minimum	70,000-95,000	70,000	65,000	70000-95,000	70,000	70,000	90,000-115,000	90,000-115,000	70,000	70,000	70,000	
Yield Strength PSI minimum	36,000	40,000	35,000	40,000	40,000	40,000	60,000	60,000	30,000	30,000	30,000	
Elongation In 2"% minimum	22	22	24	22	20	20	18	18	35	30	30	
ReductionArea "% minimum	35	35	35	35	35	35	35	35	-	-	-	
Hardness (HB) Maximum	185	185	190	200	200	200	237	237	-	-	-	

Notes:

- The percentage (%) shown on the elements is the maximum except where ranges are indicated.
- Steel CF8C should have a Columbium content of not less than 8 times the carbon content, but not exceeding 1%.

# WALWORTH CAST STEEL GATE VALVES CLASS 150

CAST STEEL GATE VALVES HANDWHEEL OR GEAR OPERATED, WITH RISING STEM AND OUT SIDE SCREW AND YOKE (OS&Y)

## DESIGN FEATURES

- Gate valves design in accordance with API-600, solid, flexible or parallel slide wedge/Disc.
- Gate valves option in accordance with API-603 only for stainless steel & nickel alloys.
- Standard manufacturing wedge from 2" to 4" solid wedge design; 5" and up flexible wedge.
- Gate and Globe valves for Cryogenic service with gas column in accordance with BS-6364 upon request.
- Flange dimensions in accordance with ASME B16.5 for valves up to 24" nominal diameter.
- Hand-wheel, impact Hand-wheel, Chain-wheel, Gear operation, Electric, Pneumatic or Hydraulic Actuation as per Customer requirements.
- By-Pass, Lantern rings, grease injectors, special connections, etc.
- Low fugitive emissions control.
- NACE Service either MR-01-75 or MR-01-03.
- Test in accordance with API-598.

- ① Stem Nut, replaceable in line to avoid shut down of pipe line process.
- ② Rising stem with precision ACME single or double thread for quick operation. Surface finish suitable to seal properly to obtain low fugitive emissions.
- ③ Stem Packing is designed for optimum control of fugitive emissions leakage to the atmosphere. The ultra-low emission leakage rate is assured by the polished finish stem sealing area, the reduced diametrical clearances and the stem straightness control special designed packing. Live load packing arrangement available upon request.
- ④ Backseat, either threaded or welded designed to relieve back pressure on the stem packing when fully seated. Replacing stem packing under pressure is not recommended. Hard faced backseat available for severe service as per customer requirements.
- ⑤ Stem-Gate connection designed so that under severe applied loads (stuck gate), the stem will fail outside of the stuffing box pressure boundary.
- ⑥ Body to Bonnet joint is designed to apply a uniform load to the gasket to assure a leak proof seal.
- ⑦ Seat rings are seal welded to provide a bubble tight joint.
- ⑧ Stellite Seat Rings provide increased resistance to wear, abrasion and erosion of the sealing surfaces.
- ⑨ Two pieces arrangement gland flange and stem packing bushing for self-alignment to avoid stem damage.
- ⑩ Gate valves supplied handwheel or gear operated.



# WALWORTH CAST STEEL GATE VALVES, CLASS 150 (HANDWHEEL OPERATED)

- Design in accordance with API - 600
- Outside Screw & Yoke (OS & Y)
- Solid Wedge: 2" to 4"
- Flexible Wedge: 5" and up
- From 2" to 24" Handwheel operated as Standard.
- Flange dimensions as per ASME B16.5
- End to end dimension as per ASME B16.10
- WE dimensions as per ASME B16.25
- Flange dimensions larger than 24" according to ASME B16.47 Series A as standard
- Flange dimensions as per ASME B16.47 Series B available upon request

Catalog Figure No.	ID Plant Figure No.	Type of Ends
5202RF	5202F	Flanged Raised Face
5202RTJ	5202RJ	Flanged Ring Type Joint
5202WE	5202WE	Buttweld

## Regular Bill of Materials

No.	DESCRIPTION	WCB Trim UT
1	Body	ASTM A 216 GR WCB
2	Bonnet	ASTM A 216 GR WCB
3	Wedge	ASTM A 216 GR WCB + 13% Cr.
4	Seat Ring	ASTM A 515 GR 70 + ST 6
5	Stem	ASTM A 276 Type 410
6	Stem Nut Retainer	ASTM A 108 GR 1020
7	Set Screw	Alloy Steel
8	Grease Fitting	Commercial Steel
9	Stem Nut	UNS C95600 or Ni-Resist
10	Eyebolt	Alloy Steel
11	Eyebolt Nut	ASTM A 307
12	Gland Flange	ASTM A 515 GR 70
13	Packing Bushing	ASTM A 108 GR 1020
14	Eyebolt Pin	Alloy Steel
15	Stem Packing	Graphite
16	Bonnet Bushing	ASTM A 276 Type 410
17	Bonnet Gasket	Graphite/Stainless 316
18	Bonnet Stud	ASTM A 193 GR B7
19	Bonnet Stud Nut	ASTM A 194 GR 2H
20	Handwheel	ASTM A 197
21	Handwheel Nut	ASTM A 108 GR 1020
*22	Set Screw	Alloy Steel
*23	Identification Plate	Stainless Steel

\*Not shown

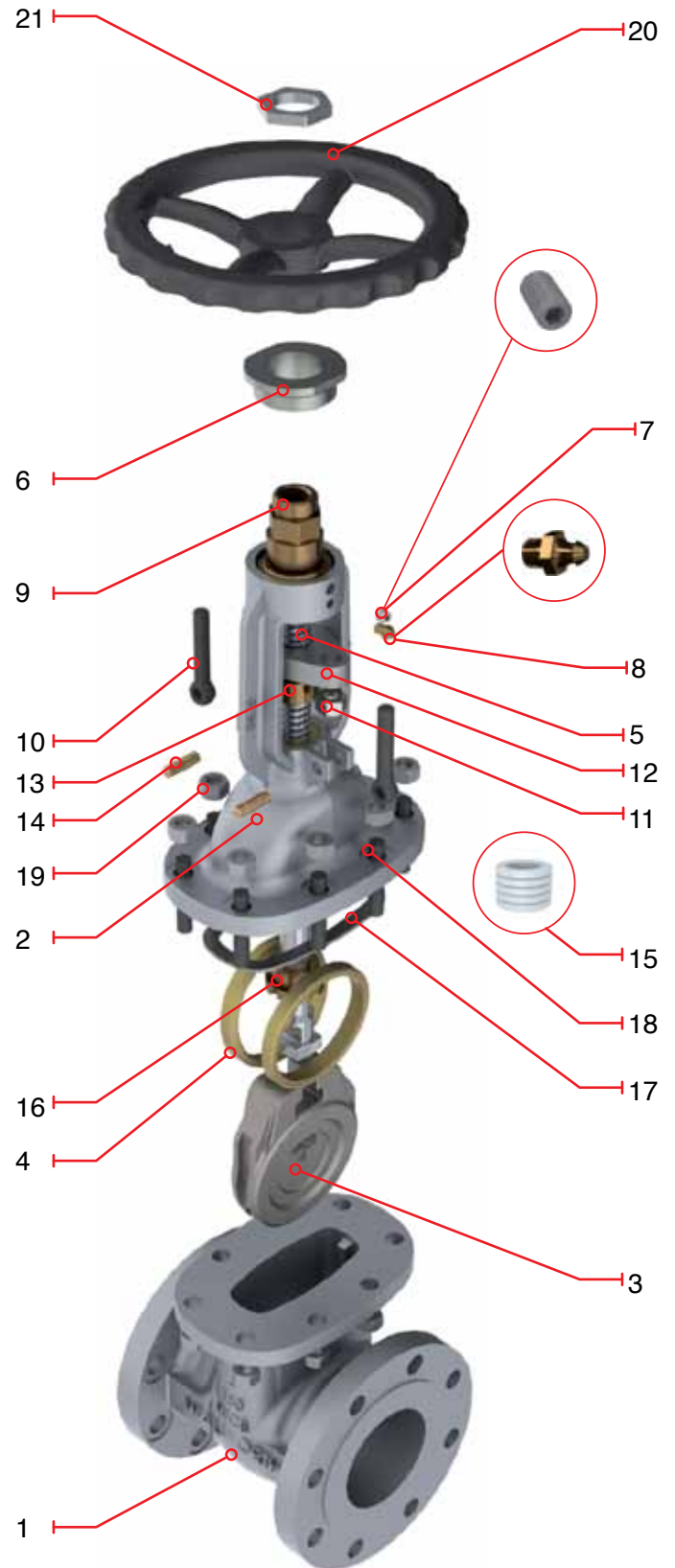

# WALWORTH CAST STEEL GATE VALVES, CLASS 150 (HANDWHEEL OPERATED)



- Design in accordance with API - 600
- Outside Screw & Yoke (OS & Y)
- Solid Wedge: 2" to 4"
- Flexible Wedge: 5" and up
- From 2" to 24" Handwheel operated as Standard.
- Flange Dimensions as per ASME B16.5
- End to end dimension as per ASME B16.10
- WE dimensions as per ASME B16.25

Catalog Figure No.	ID Plant Figure No.	Type of Ends
5202RF	5202F	Flanged Raised Face
5202RTJ	5202RJ	Flanged Ring Type Joint
5202WE	5202WE	Buttweld

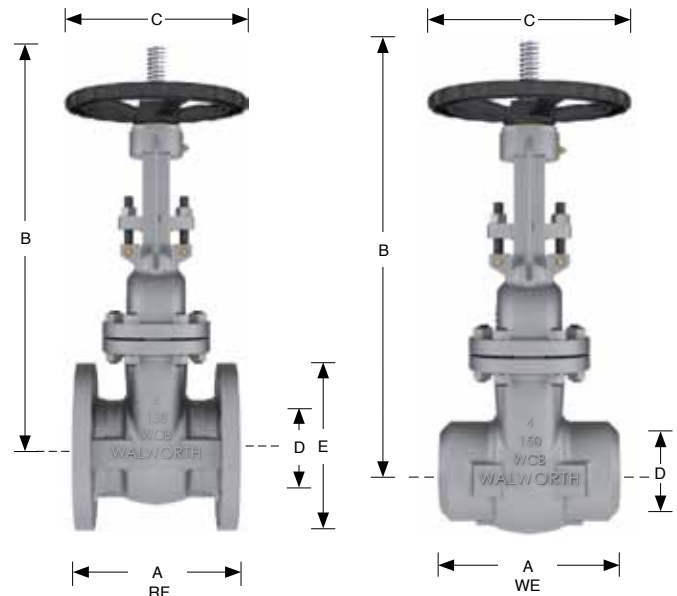

## Dimensions and Weights

D															
Nominal Diameter	mm.	51	64	76	102	127	152	203	254	305	356	406	457	508	610
	inch	2	2 1/2	3	4	5	6	8	10	12	14	16	18	20	24
A (RF)	mm.	178	191	203	229	254	267	292	330	356	381	406	432	457	508
	inch	7	7 1/2	8	9	10	10 1/2	11 1/2	13	14	15	16	17	18	20
A (WE)	mm.	216	241	283	305	381	403	419	457	502	572	610	660	711	813
	inch	8 1/2	9 1/2	11 1/8	12	15	15 7/8	16 1/2	18	19 3/4	22 1/2	24	26	28	32
B	mm.	478	483	552	675	813	830	1,062	1,253	1,461	1,661	1,835	2,027	2,265	2,711
	inch	18 13/16	19	21 3/4	26 9/16	32	32 11/16	41 13/16	49 5/16	57 1/2	65 3/8	72 1/4	79 13/16	89 3/16	106 3/4
C	mm.	203	178	254	254	305	305	356	406	508	559	660	711	762	864
	inch	8	7	10	10	12	12	14	16	20	22	26	28	30	34
E	mm.	152	178	191	229	254	279	343	406	483	533	597	635	699	813
	inch.	6	7	7 1/2	9	10	11	13 1/2	16	19	21	23 1/2	25	27 1/2	32
Weight 5202RF	kg.	19	30	32	48	71	77	132	199	271	449	541	724	1004	1522
	lb.	42	66	70	106	156	169	290	438	596	988	1190	1593	2209	3348
Weight 5202WE	kg	15	27	31	44	60	74	116	172	247	350	506	575	720	1130
	lb.	33	59	68	97	132	163	255	378	543	770	1113	1265	1584	2486

# WALWORTH CAST STEEL GATE VALVES, CLASS 150 (GEAR OPERATED)

- Design in accordance with API-600
- Outside Screw & Yoke (OS & Y)
- Flexible Wedge: 5" and up
- Size 30" up to 72", supplied with GEAR BOX as standard
- Flange dimensions as per ASME B16.47 Series A. Series B available upon request
- End to end dimensions as per ASME B16.10
- WE dimensions as per ASME B16.25

Catalog Figure No.	ID Plant Figure No.	Type of Ends
5202RF	5202F	Flanged Raised Face
5202RTJ	5202RJ	Flanged Ring Type Joint
5202WE	5202WE	Buttweld

## Regular Bill of Materials

No.	DESCRIPTION	WCB Trim UT
1	Body	ASTM A 216 GR WCB
2	Bonnet	ASTM A 216 GR WCB
3	Wedge	ASTM A 216 GR WCB + 13% Cr.
4	Seat Ring	ASTM A 515 GR 70 + ST 6
5	Stem	ASTM A 276 Type 410
6	Yoke	ASTM A 216 GR WCB
7	Stem Nut Retainer	ASTM A 36
8	Eyebolt / Gland Flange Studs	Alloy Steel
9	Eyebolt Nut	ASTM A 307
10	Gland	ASTM A 515 GR 70
11	Packing Bushing	ASTM A 108 GR 1020
12	Eyebolt Pin	Alloy Steel
13	Stem Packing	Graphite
14	Bonnet Bushing	ASTM A 276 Type 410
15	Bonnet Gasket	Graphite/Stainless 316
16	Bonnet Stud	ASTM A 193 GR B7
17	Bonnet Stud Nut	ASTM A 194 GR 2H
18	Gear Operator	as customer requirements
19	Operator Bolts	Alloy Steel
20	Yoke Stud	Alloy Steel
21	Yoke Stud Nut	ASTM A 307
22	Retainer Bolt	Alloy Steel
*23	Identification Plate	Stainless Steel

\*Not shown

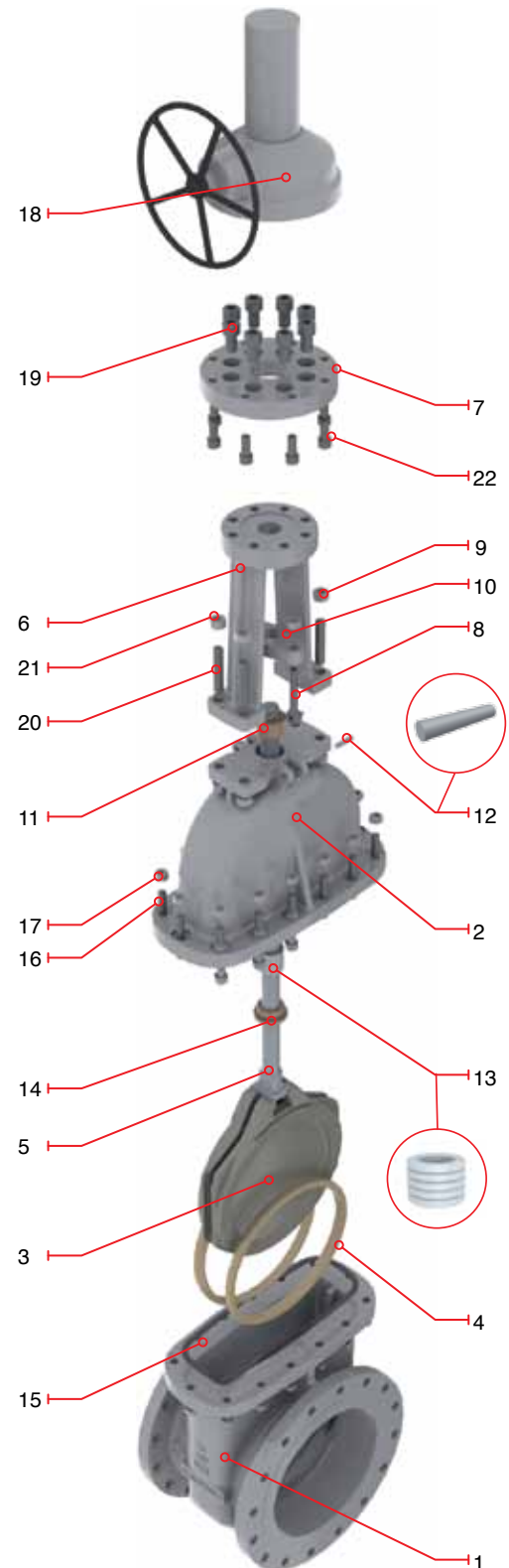

# WALWORTH CAST STEEL GATE VALVES, CLASS 150 (GEAR OPERATED)



- Design in accordance with API-600
- Outside Screw & Yoke (OS & Y)
- Flexible Wedge: 5" and up
- Size 30" up to 72", supplied with GEAR BOX as standard
- Flange dimensions as per ASME B16.47 Series A. Series B available upon request
- End to end dimensions as per ASME B16.10
- WE dimensions as per ASME B16.25

Catalog Figure No.	ID Plant Figure No.	Type of Ends
5202RF	5202F	Flanged Raised Face
5202RTJ	5202RJ	Flanged Ring Type Joint
5202WE	5202WE	Buttweld

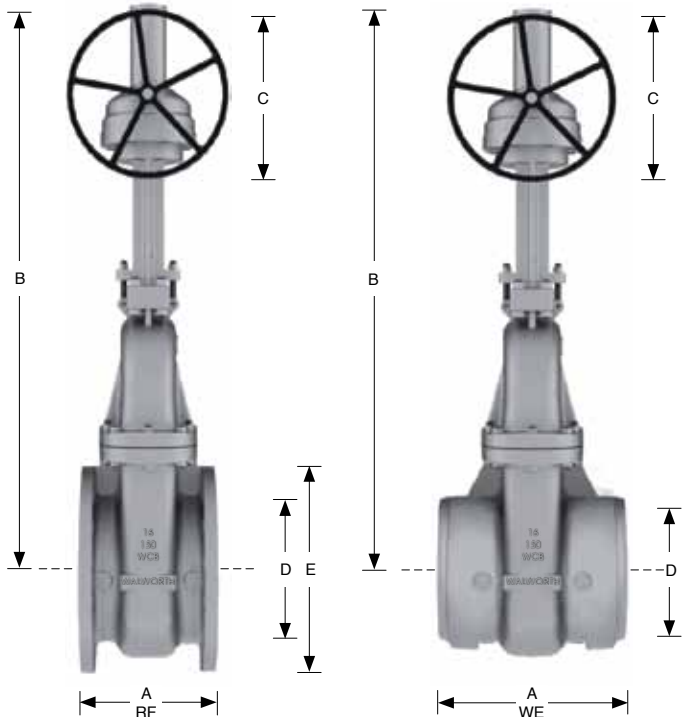

## Dimensions and Weights

D Nominal Diameter	mm. inch	762 30	914 36	1067 42	1219 48	1372 54	1524 60	1829 72
A (RF)	mm. inch	610 24	711 28	787 31	864 34	965 38	1067 42	1397 55
A (WE)	mm. inch	762 30	864 34	965 38	1016 40	1118 44	1219 48	1575 62
B	mm. inch	3,239 127 1/2	3,886 153	4,534 178 1/2	5,182 204	5,829 229 1/2	6,477 255	7,772 306
C	mm. inch	610 24	610 24	610 24	610 24	762 30	762 30	762 30
E	mm. inch	984 38 3/4	1168 46	1346 53	1511 59 1/2	1676 66	1854 73	2184 86
Weight 5202RF	kg. lb.	2242 4932	3470 7634	5300 11660	7050 15510	10310 22682	14890 32758	23200 51040
Weight 5202WE	kg. lb.	1910 4202	3198 7035.6	4880 10736	6490 14278	9490 20878	13700 30140	21350 46970

# WALWORTH CAST STEEL GATE VALVES CLASS 300

CAST STEEL GATE VALVES HANDWHEEL OR GEAR OPERATED, WITH RISING STEM AND OUT SIDE SCREW AND YOKE (OS&Y)

## DESIGN FEATURES

- Gate valves design in accordance with API-600, solid, flexible or parallel slide wedge/Disc.
- Gate valves option in accordance with API-603 only for stainless steel & nickel alloys.
- Standard manufacturing wedge from 2" to 4" solid wedge design; 5" and up flexible wedge.
- Gate and Globe valves for Cryogenic service with gas column in accordance with BS-6364 upon request.
- Flange dimensions in accordance with ASME B16.5 for valves up to 24" nominal diameter.
- Hand-wheel, impact Hand-wheel, Chain-wheel, Gear operation, Electric, Pneumatic or Hydraulic Actuation as per Customer requirements.
- By-Pass, Lantern rings, grease injectors, special connections, etc.
- Low fugitive emissions control.
- NACE Service either MR-01-75 or MR-01-03.
- Test in accordance with API-598.

① Stem Nut, replaceable in line to avoid shut down of pipe line process.

② Rising stem with precision ACME single or double thread for quick operation. Surface finish suitable to seal properly to obtain low fugitive emissions.

③ Stem Packing is designed for optimum control of fugitive emissions leakage to the atmosphere. The ultra-low emission leakage rate is assured by the polished finish stem sealing area, the reduced diametrical clearances and the stem straightness control special designed packing. Live load packing arrangement available upon request.

④ Backseat, either threaded or welded designed to relieve back pressure on the stem packing when fully seated. Replacing stem packing under pressure is not recommended. Hard faced backseat available for severe service as per customer requirements.

⑤ Stem-Gate connection designed so that under severe applied loads (stuck gate), the stem will fail outside of the stuffing box pressure boundary.

⑥ Body to Bonnet joint is designed to apply a uniform load to the gasket to assure a leak proof seal.

⑦ Seat rings are seal welded to provide a bubble tight joint.

⑧ Stellite Seat Rings provide increased resistance to wear, abrasion and erosion of the sealing surfaces.

⑨ Two pieces arrangement gland flange and stem packing bushing for self-alignment to avoid stem damage.

⑩ Gate valves supplied handwheel or gear operated.

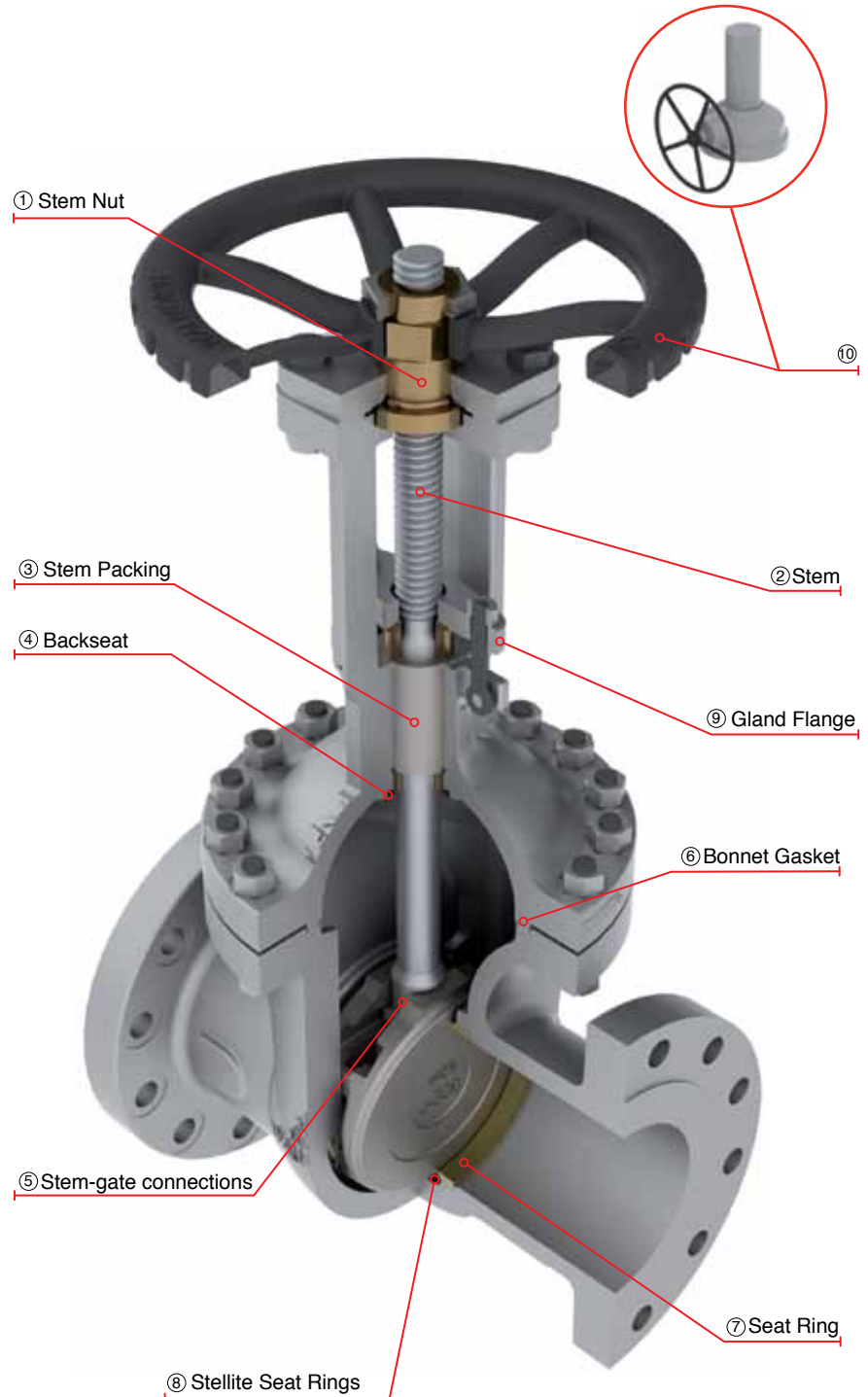



# WALWORTH CAST STEEL GATE VALVES, CLASS 300 (HANDWHEEL OPERATED)

- Design in accordance with API-600
- Outside Screw & Yoke (OS & Y)
- Solid Wedge: 2" to 4"
- Flexible Wedge : 5" and up
- From 2" to 24" Handwheel operated as Standard.
- Flange Dimensions as per ASME B16.5
- End to end dimensions as per ASME B16.10
- WE dimensions as per ASME B16.25
- Flange dimensions larger than 24" according to ASME B16.47 Series A as standard
- Flange dimensions as per ASME B16.47 Series B available upon request

Catalog Figure No.	ID Plant Figure No.	Type of Ends
5206RF	5206F	Flanged Raised Face
5206RTJ	5206RJ	Flanged Ring Type Joint
5206WE	5206WE	Buttweld

## Regular Bill of Materials

No.	DESCRIPTION	STANDARD MATERIAL
1	Body	ASTM A 216 GR WCB
2	Yoke/Bonnet	ASTM A 216 GR WCB
3	Wedge	ASTM A 216 GR WCB + 13% Cr.
4	Seat Ring	ASTM A 515 GR 70
5	Stem	ASTM A 276 Type 410
*6	Stem Nut Retainer	ASTM A 108 GR 1020
7	Stem Retainer	Alloy Steel
8	Grease Fitting	Commercial Steel
9	Stem Nut	UNS C95600 or Ni-Resist
10	Eyebolt	Alloy Steel
11	Eyebolt Nut	ASTM A 307
12	Gland Flange	ASTM A 515 GR 70
13	Packing Bushing	ASTM A 108 GR 1020
14	Eyebolt Pin	Alloy Steel
15	Stem Packing	Graphite
16	Bonnet Bushing	ASTM A 276 Type 410
17	Bonnet Gasket	Spiral Stainless 304/Graphite
18	Bonnet Stud	ASTM A 193 GR B7
19	Bonnet Stud Nut	ASTM A 194 GR 2H
20	Handwheel	ASTM A 197
21	Handwheel Nut	ASTM A 108 GR 1020
22	Set Screw	Alloy Steel
*23	Identification Plate	Stainless Steel

\*Not Shown

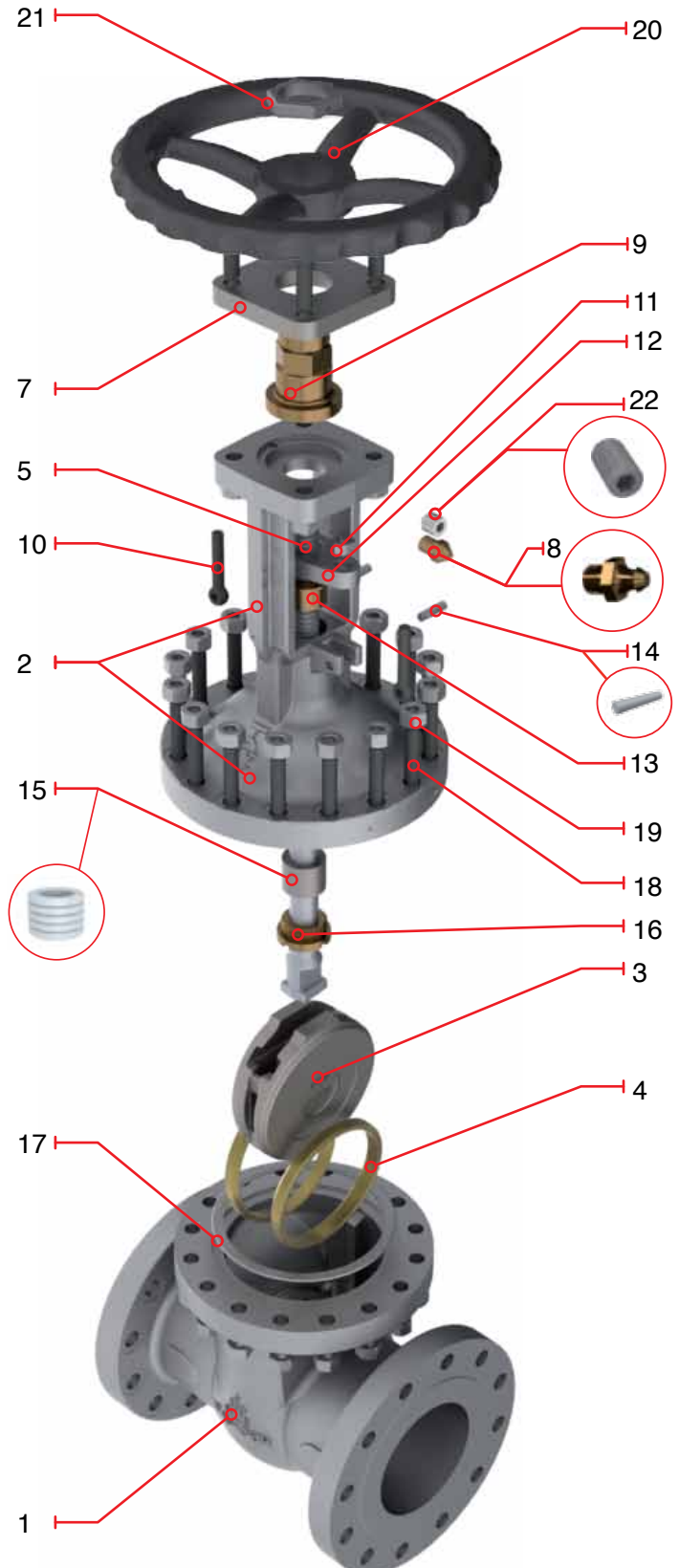

# WALWORTH CAST STEEL GATE VALVES, CLASS 300 (HANDWHEEL OPERATED)



- Design in accordance with API-600
- Solid Wedge: 2" to 4"
- Flexible wedge 5" and up
- From 2" to 24" Handwheel operated as Standard.
- Flange dimensions as per ASME B16.5
- End to end dimensions as per ASME B16.10
- WE dimensions as per ASME B16.25

Catalog Figure No.	ID Plant Figure No.	Type of Ends
5206RF	5206F	Flanged Raised Face
5206RTJ	5206RJ	Flanged Ring Type Joint
5206WE	5206WE	Buttweld

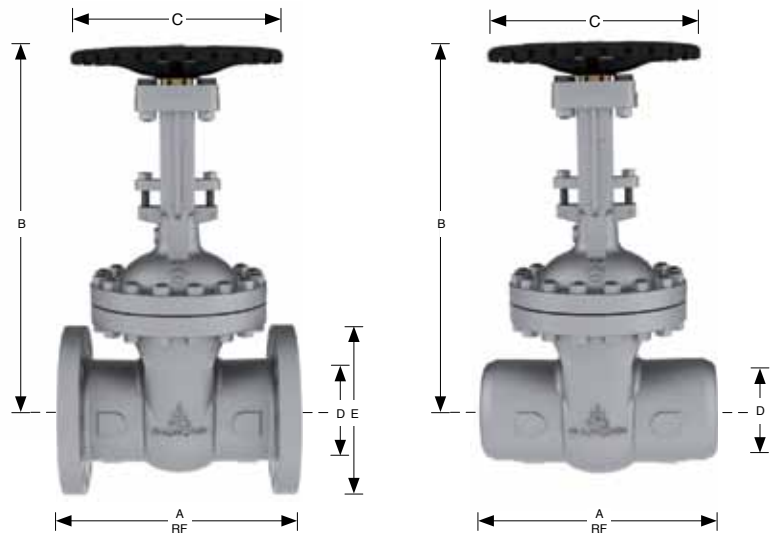

D																
Nominal Diameter	mm.	51	64	76	102	127	152	203	254	305	356	406	457	508	610	
	inch	2	2 1/2	3	4	5	6	8	10	12	14	16	18	20	24	
A (RF y WE)	mm.	216	241	283	305	381	403	419	457	502	762	838	914	991	1143	
	inch	8 1/2	9 1/2	11 1/8	12	15	15 7/8	16 1/2	18	19 3/4	30	33	36	39	45	
B	mm.	473	579	528	637	695	935	1083	1314	1594	1730	1924	2105	2334	2810	
	inch	18 5/8	22 13/16	20 25/32	25 1/16	27 3/8	36 13/16	42 5/8	51 3/4	62 3/4	68 1/8	75 3/4	82 7/8	91 7/8	110 5/8	
C	mm.	203	203	254	254	300	356	406	508	508	660	711	864	864	864	
	inch	8	8	10	10	11 13/16	14	16	20	20	26	28	34	34	34	
E	mm.	165	191	210	254	279	318	381	445	521	584	648	711	775	914	
	inch	6 1/2	7 1/2	8 1/4	10	11	12 1/2	15	17 1/2	20 1/2	23	25 1/2	28	30 1/2	36	
Weight 5206RF	kg.	25	39	43	70	92	137	222	322	470	760	1202	1633	2064	2268	
	lb.	55	86	95	154	202	301	488	708	1034	1672	2644	3593	4541	4990	
Weight 5206WE	kg.	20	38	33	51	78	129	194.6	299.9	407.3	669	1043	1383	1864	1950	
	lb.	44	83.6	72.6	112.2	172.04	283.8	428.12	659.78	896.06	1471.36	2294.6	3042.6	4100.8	4290	

# WALWORTH CAST STEEL GATE VALVES, CLASS 300 (GEAR OPERATED)

- Design in accordance with API-600
- Outside Screw & Yoke (OS & Y)
- Flexible Wedge : 5" and up
- Size 30" and up to 42", supplied with GEAR operator as standard.
- Flange dimensions as per ASME B16.47 Series A. Series B available upon request.
- End to end dimensions as per ASME B16.10
- WE dimensions as per ASME B16.25

Catalog Figure No.	ID Plant Figure No.	Type of Ends
5206RF	5206F	Flanged Raised Face
5206RTJ	5206RJ	Flanged Ring Type Joint
5206WE	5206WE	Buttweld

## Regular Bill of Materials

No.	DESCRIPTION	WCB Trim UT
1	Body	ASTM A 216 GR WCB
2	Bonnet	ASTM A 216 GR WCB
3	Wedge	ASTM A 216 GR WCB + 13% Cr.
4	Seat Ring	ASTM A 515 GR 70 + ST 6
5	Stem	ASTM A 276 Type 410
6	Yoke	ASTM A 216 GR WCB
7	Stem Nut Retainer	ASTM A 36
8	Eyebolt / Gland Flange Studs	Alloy Steel
9	Eyebolt Nut	ASTM A 307
10	Gland Flange	ASTM A 515 GR 70
11	Packing Bushing	ASTM A 108 GR 1020
12	Eyebolt Pin	Alloy Steel
13	Stem Packing	Graphite
14	Bonnet Bushing	ASTM A 276 Type 410
15	Bonnet Gasket	Graphite/Stainless 316
16	Bonnet Stud	ASTM A 193 GR B7
17	Bonnet Stud Nut	ASTM A 194 GR 2H
18	Gear Operator	as customer requirements
19	Operator Bolts	Alloy Steel
20	Yoke Stud	Alloy Steel
21	Yoke Stud Nut	ASTM A 307
22	Retainer Bolt	Alloy Steel
*23	Identification Plate	Stainless Steel

\*Not Shown

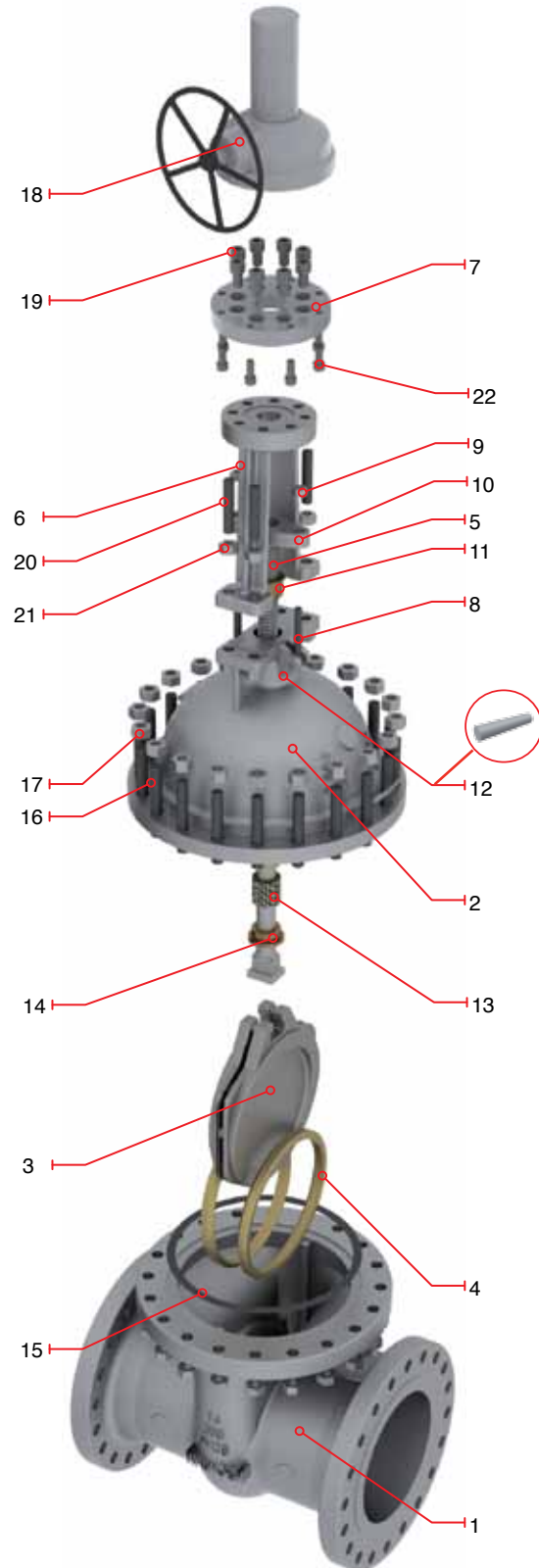

# WALWORTH CAST STEEL GATE VALVES, CLASS 300

## (GEAR OPERATED)

- Design in accordance with API-600
- Outside Screw & Yoke (OS & Y)
- Flexible Wedge : 5" and up
- Size 30" and up to 42", supplied with GEAR operator as standard.
- Flange dimensions as per ASME B16.47 Series A. Series B available upon request.
- End to end dimensions as per ASME B16.10
- WE dimensions as per ASME B16.25



Catalog Figure No.	ID Plant Figure No.	Type of Ends
5206RF	5206F	Flanged Raised Face
5206RTJ	5206RJ	Flanged Ring Type Joint
5206WE	5206WE	Buttweld

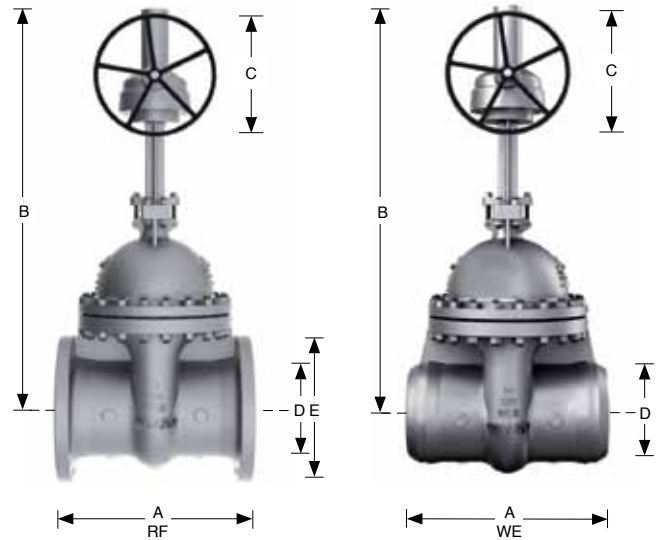

### Dimensions and Weights

D	Nominal Diameter	mm.	762	914	1067
		inch	30	36	42
A		mm.	1397	1727	2172
	(RF y WE)	inch	55	68	85 1/2
B		mm.	3277	3932	4481
		inch	129	154 13/16	176 7/16
C		mm.	762	762	762
		inch	30	30	30
E		mm.	1092	1270	1291
		inch.	43	50	50 13/16
Weight		kg.	3680	6500	11405
	5206RF	lb.	8096	14300	25091
Weight		kg	3128	5525	9494
	5206WE	lb.	6882	12155	20887

# WALWORTH CAST STEEL GATE VALVES CLASS 600

CAST STEEL GATE VALVES HANDWHEEL OR GEAR OPERATED, WITH RISING STEM AND OUT SIDE SCREW AND YOKE (OS&Y)

## DESIGN FEATURES

- Gate valves design in accordance with API-600, solid, flexible or parallel slide wedge/Disc.
- Gate valves option in accordance with API-603 only for stainless steel & nickel alloys.
- Gate and Globe valves for Cryogenic service with gas column in accordance with BS-6364 upon request.
- Flange dimensions in accordance with ASME B16.5 for valves up to 24" nominal diameter.
- Hand-wheel, impact Hand-wheel, Chain-wheel, Gear operation, Electric, Pneumatic or Hydraulic Actuation as per Customer requirements.
- By-Pass, Lantern rings, grease injectors, special connections, etc.
- Low fugitive emissions control.
- NACE Service either MR-01-75 or MR-01-03.
- Test in accordance with API-598.
- Standard manufacturing flexible wedge from 2" and up

- ① Stem Nut, replaceable in line to avoid shut down of pipe line process.
- ② Rising stem with precision ACME single or double thread for quick operation. Surface finish suitable to seal properly to obtain low fugitive emissions.
- ③ Stem Packing is designed for optimum control of fugitive emissions leakage to the atmosphere. The ultra-low emission leakage rate is assured by the polished finish stem sealing area, the reduced diametrical clearances and the stem straightness control special designed packing. Live load packing arrangement available upon request.
- ④ Backseat, either threaded or welded designed to relieve back pressure on the stem packing when fully seated. Replacing stem packing under pressure is not recommended. Hard faced backseat available for severe service as per customer requirements.
- ⑤ Stem-Gate connection designed so that under severe applied loads (stuck gate), the stem will fail outside of the stuffing box pressure boundary.
- ⑥ Body to Bonnet ring type joint is designed to apply a uniform load to the gasket to assure a leak proof seal.
- ⑦ Seat rings are seal welded to provide a bubble tight joint.
- ⑧ Stellite Seat Rings provide increased resistance to wear, abrasion and erosion of the sealing surfaces.
- ⑨ Two pieces arrangement gland flange and stem packing bushing for self-alignment to avoid stem damage.
- ⑩ Gate valves supplied handwheel or gear operated.

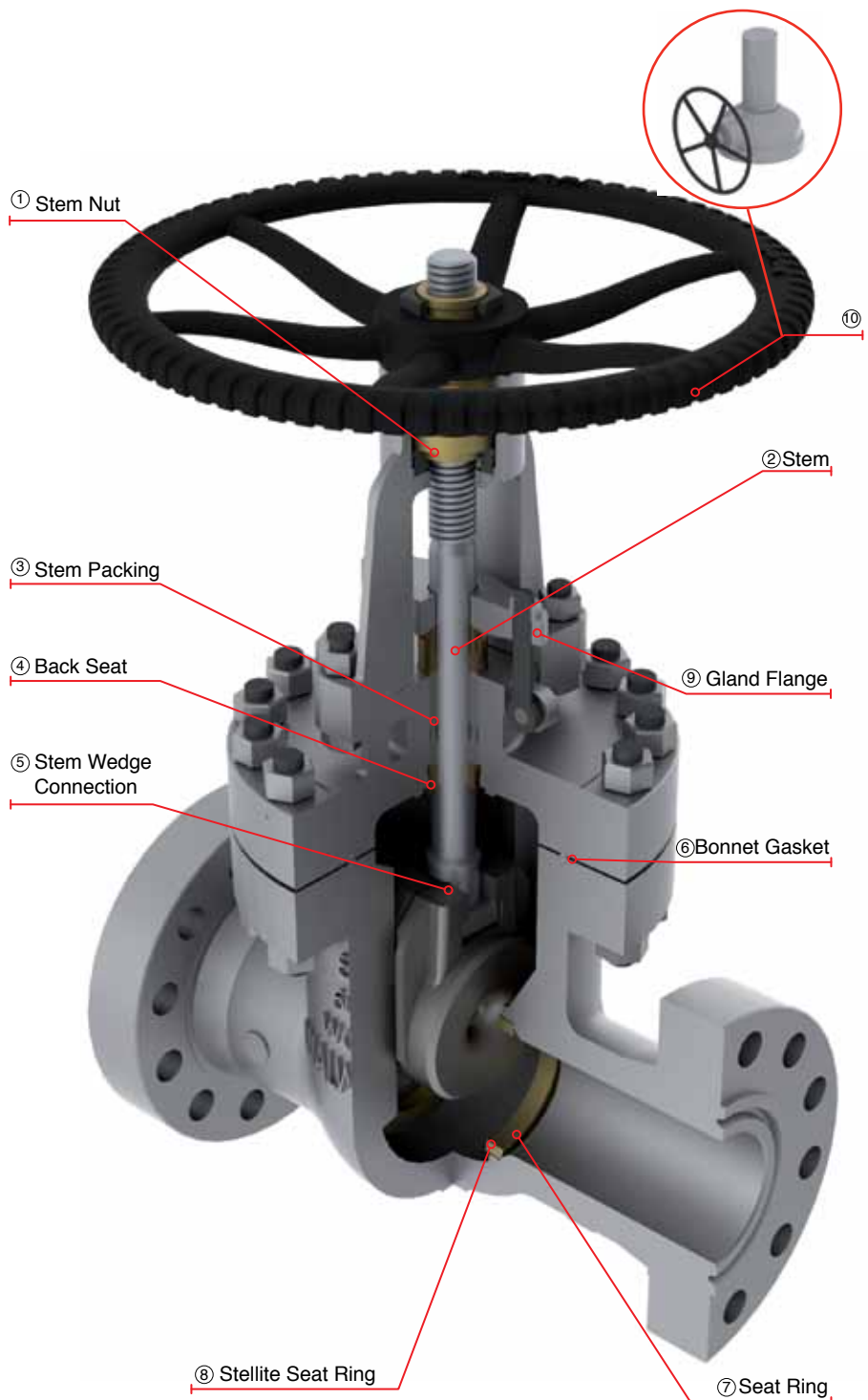

# WALWORTH CAST STEEL GATE VALVES, CLASS 600 (HANDWHEEL OPERATED)

- Design in accordance with API-600
- Outside Screw & Yoke (OS & Y)
- Flexible Wedge
- From 2" to 20" Handwheel operated as Standard.
- Flange dimensions as per ASME B16.5
- End to end dimensions as per ASME B16.10
- WE dimensions as per ASME B16.25
- Flange dimensions larger than 24" according to ASME B16.47 Series A as standard
- Flange dimensions as per ASME B16.47 Series B available upon request

Catalog Figure No.	ID Plant Figure No.	Type of Ends
5232RF	5232F	Flanged Raised Face
5232RTJ	5232RJ	Flanged Ring Type Joint
5232WE	5232WE	Buttweld

## Regular Bill of Materials

No.	DESCRIPTION	WCB Trim UT
1	Body	ASTM A 216 GR WCB
2	Bonnet	ASTM A 216 GR WCB
3	Wedge	ASTM A 216 GR WCB + 13% Cr.
4	Seat Ring	ASTM A 515 GR 70 + ST6
5	Stem	ASTM A 276 Type 410
6	Yoke	ASTM A 216 GR WCB
7	Stem Nut Retainer	ASTM A 36
8	Grease Fitting	Commercial Steel
9	Stem Nut	UNS C95600 or Ni-Resist
10	Eyebolt / Gland Flange Studs	Alloy Steel
11	Eyebolt Nut	ASTM A 307
12	Gland Flange	ASTM A 515 GR 70
13	Packing Bushing	ASTM A 108 GR 1020
14	Eye Lug Bolt / Eyebolt Pin	Alloy Steel
15	Stem Packing	Graphite
16	Bonnet Bushing	ASTM A 276 Type 410
17	Ring Type Joint Gasket	ASTM A 108 GR 1010
18	Bonnet Stud	ASTM A 193 GR B7
19	Bonnet Stud Nut	ASTM A 194 GR 2H
20	Handwheel	ASTM A 197
21	Handwheel Nut	ASTM A 108 GR 1020
22	Set Screw	Alloy Steel
23	Yoke Bolt	Alloy Steel
24	Yoke Bolt Nut	ASTM A 307
25	Stem Nut Bearing	Commercial Steel
*26	Stem Nut Oil Seal	Rubber/Commercial Steel
*27	Identification Plate	Stainless Steel

\*Not Shown

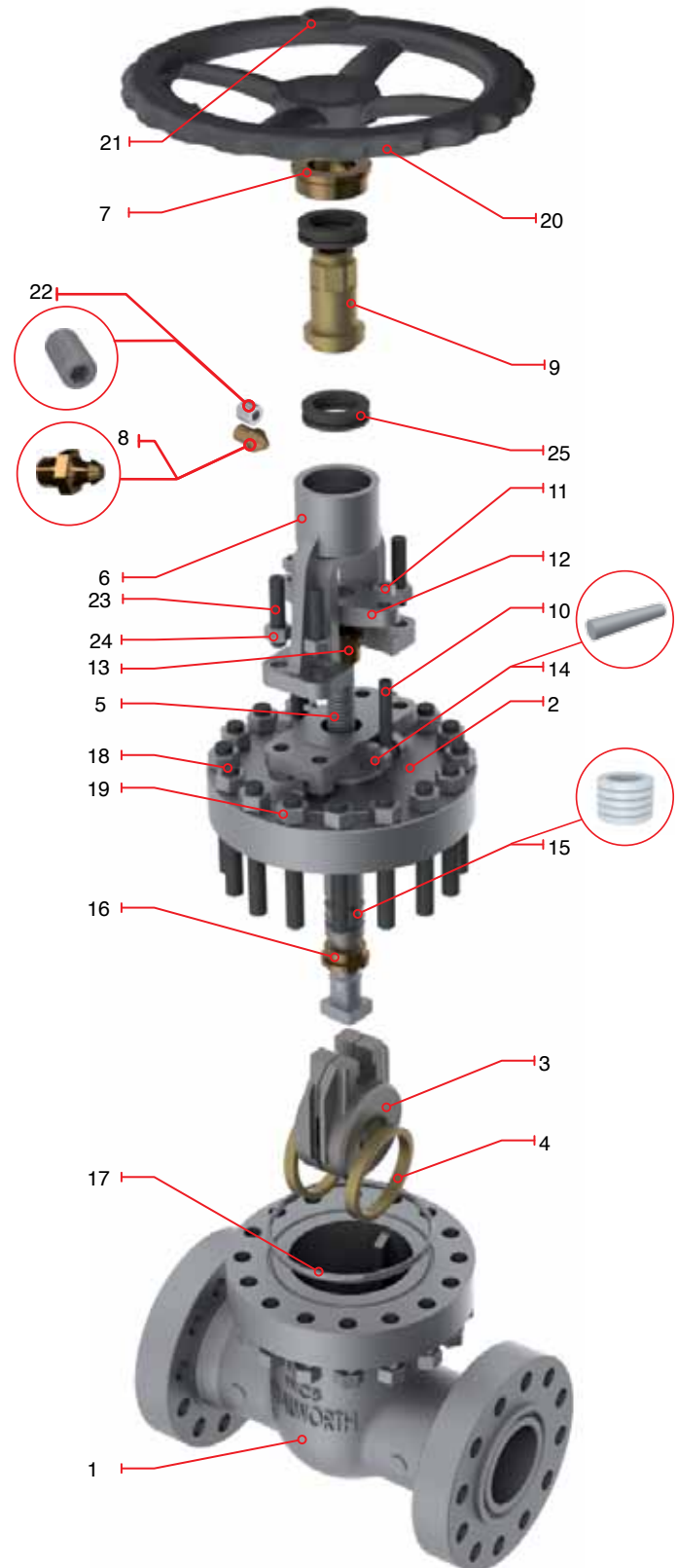

# WALWORTH CAST STEEL GATE VALVES, CLASS 600 (HANDWHEEL OPERATED)

- Design in accordance with API-600
- Outside Screw & Yoke (OS & Y)
- Flexible Wedge
- From 2" to 20" Handwheel operated as Standard.
- Flange dimensions as per ASME B16.5
- End to end dimensions as per ASME B16.10
- WE dimensions as per ASME B16.25

Catalog Figure No.	ID Plant Figure No.	Type of Ends
5232RF	5232F	Flanged Raised Face
5232RTJ	5232RJ	Flanged Ring Type Joint
5232WE	5232WE	Buttweld

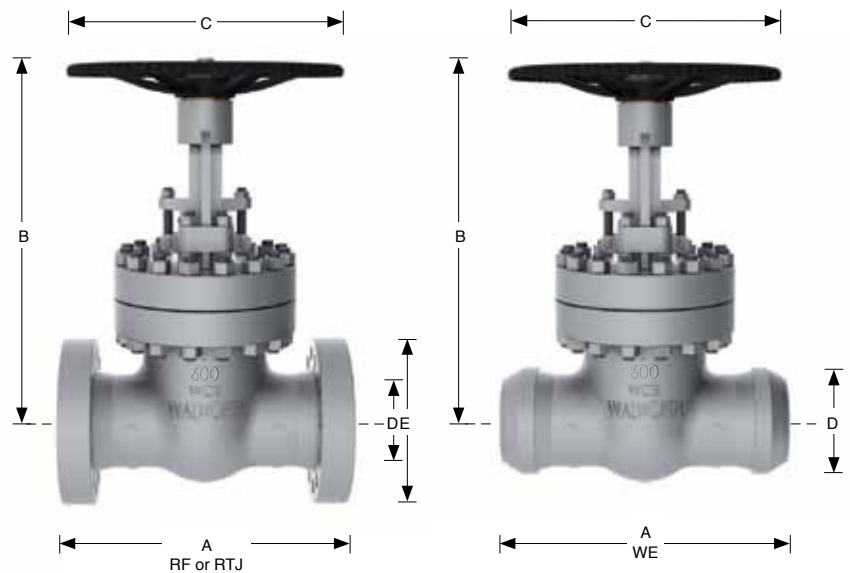

## Dimensions and Weights

D														
Nominal Diameter	mm.	51	64	76	102	152	203	254	305	356	406	457	508	
	inch	2	2 1/2	3	4	6	8	10	12	14	16	18	20	
A (RF y WE)	mm.	292	330	356	432	559	660	787	838	889	991	1,092	1,194	
	inch	11 1/2	13	14	17	22	26	31	33	35	39	43	47	
A (RTJ)	mm.	295	333	359	435	562	663	790	841	892	994	1095	1200	
	inch	11 5/8	13 1/8	14 1/8	17 1/8	22 1/8	26 1/8	31 1/8	33 1/8	35 1/8	39 1/8	43 1/8	47 1/4	
B	mm.	432	495	546	673	845	1105	1283	1461	1676	1803	1956	2286	
	inch	17	19 1/2	21 1/2	26 1/2	33 1/4	43 1/2	50 1/2	57 1/2	66	71	77	90	
C	mm.	254	254	254	305	457	508	660	660	711	711	914	914	
	inch	10	10	10	12	18	20	26	26	28	28	36	36	
E	mm.	165	191	210	273	356	419	508	559	603	686	743	813	
	inch.	6 1/2	7 1/2	8 1/4	10 3/4	14	16 1/2	20	22	23 3/4	27	29 1/4	32	
Weight 5232RF/RTJ	kg.	37	53	65	115	224	440	653	863	1141	1565	2560	3000	
	lb.	80.3	116.6	143	253	492.8	968	1436.6	1898.6	2510.2	3443	5632	6600	
Weight 5232WE	kg	35	41	63	100	195	429	568	751	993	1362	2086	2705	
	lb.	77	90.2	138.6	220.11	428.736	943.8	1249.842	1651.782	2183.874	2995.41	4589.2	5951	

# WALWORTH CAST STEEL GATE VALVES, CLASS 600 (GEAR OPERATED)

- Design in accordance with API-600
- Outside Screw & Yoke (OS & Y)
- Flexible Wedge
- Size 24" and up to 36", supplied with gear operated as standard.
- Stem Nut with bearings 6" and up
- Flange dimensions for 24" as per ASME B16.5
- End to end dimensions as per ASME B16.10
- WE dimensions as per ASME B16.25
- Flange dimensions larger than 24" in accordance with ASME B16.47 Series A
- Flange dimensions as per ASME B16.47 Series B available upon request

Catalog Figure No.	ID Plant Figure No.	Type of Ends
5232RF	5232F	Flanged Raised Face
5232RTJ	5232RJ	Flanged Ring Type Joint
5232WE	5232WE	Buttweld

## Regular Bill of Materials

No.	DESCRIPTION	WCB Trim UT
1	Body	ASTM A 216 GR WCB
2	Bonnet	ASTM A 216 GR WCB
3	Wedge	ASTM A 216 GR WCB + 13% Cr.
4	Seat Ring	ASTM A 515 GR 70 + ST6
5	Stem	ASTM A 276 Type 410
6	Yoke	ASTM A 216 GR WCB
7	Stem Nut Retainer	ASTM A 36
8	Stem Nut	ASTM B 148 UNS C95600
9	Eyebolt / Gland Flange Studs	Alloy Steel
10	Eyebolt Nut	ASTM A 307
11	Gland Flange	ASTM A 515 GR 70
12	Packing Bushing	ASTM A 108 GR 1020
13	Eye Lug Bolt / Eye Bolt Pin	Alloy Steel
14	Stem Packing	Graphite
15	Bonnet Bushing	ASTM A 276 Type 410
16	Ring Type Joint Gasket	ASTM A 108 GR 1010
17	Bonnet Stud	ASTM A 193 GR B7
18	Bonnet Stud Nut	ASTM A 194 GR 2H
19	Gear Operator	as customer requirements
20	Operator Bolts	Alloy Steel
21	Yoke Bolts	Alloy Steel
*22	Yoke Bolt Nut	ASTM A 307
*23	Identification Plate	Stainless Steel

\*Not Shown

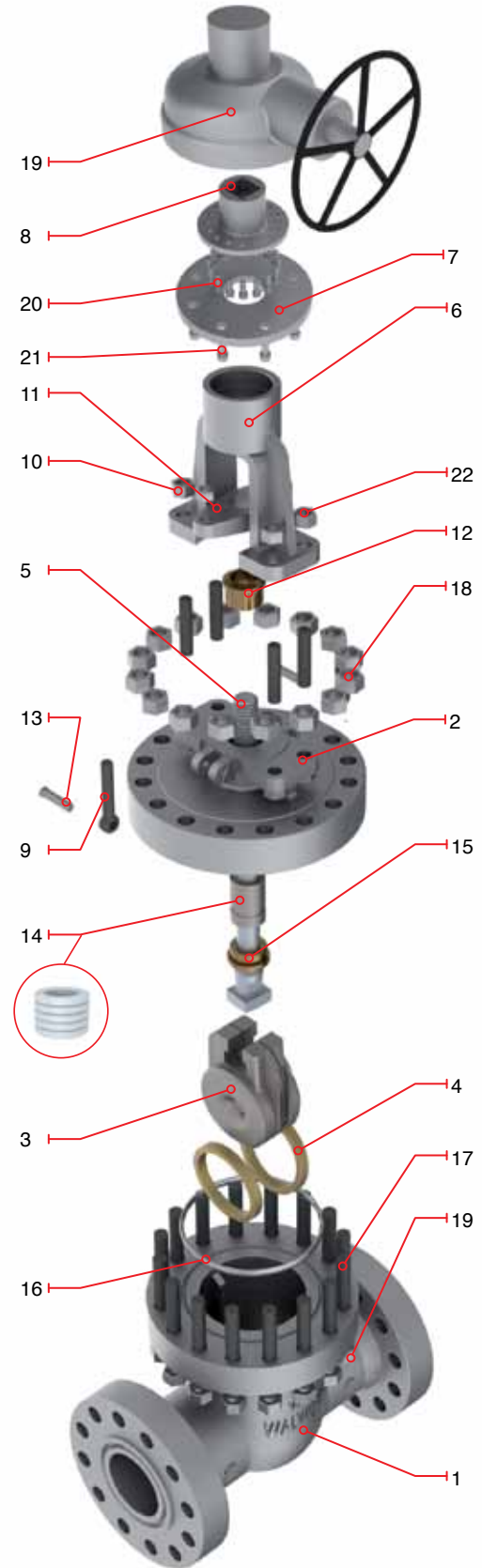



# WALWORTH CAST STEEL GATE VALVES, CLASS 600 (GEAR OPERATED)

- Design in accordance with API-600
- Outside Screw & Yoke (OS & Y)
- Flexible Wedge
- Size 24" and 36", supplied with GEAR OPERATOR as standard.
- Flange Dimensions for 24" as per ASME B16.5
- Flange dimensions larger than 24" according to ASME B16.47 Series A as standard
- Flange dimensions as per ASME B16.47 Series B available upon request



Catalog Figure No.	ID Plant Figure No.	Type of Ends
5232RF	5232F	Flanged Raised Face
5232RTJ	5232RJ	Flanged Ring Type Joint
5232WE	5232WE	Buttweld

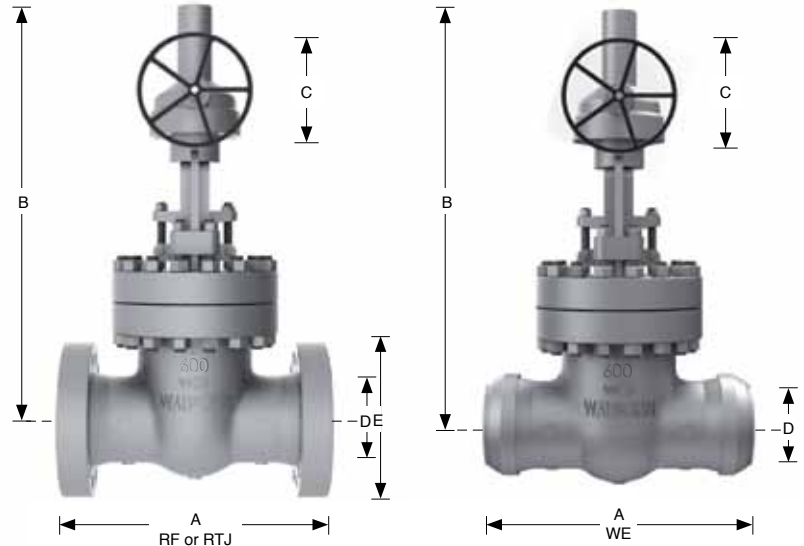

## Dimensions and Weights

D		610	762	914
Nominal Diameter	mm. inch	24	30	36
A (RF y WE)	mm.	1,397	1,651	2,083
	inch	55	65	82
A (RTJ)	mm.	1,407	1,664	2,099
	inch	55 3/8	65 1/2	82 5/8
B	mm.	2743	3429	4115
	inch	108	135	162
C	mm.	762	762	762
	inch	30	30	30
E	mm.	940	1130	1315
	inch.	37	44 1/2	51 3/4
Weight 5232RF/RTJ	kg.	4300	9890	14000
	lb.	9460	21758	30800
Weight 5232WE	kg.	3901	8406	11900
	lb.	8582	18493	26180

# WALWORTH CAST STEEL GATE VALVES CLASS 900

CAST STEEL GATE VALVES HANDWHEEL OR GEAR OPERATED, WITH RISING STEM AND OUT SIDE SCREW AND YOKE (OS&Y)

## DESIGN FEATURES

- Gate valves design in accordance with API-600, solid, flexible or parallel slide wedge/Disc.
- Gate valves option in accordance with API-603 only for stainless steel & nickel alloys.
- Gate and Globe valves for Cryogenic service with gas column in accordance with BS-6364 upon request.
- Flange dimensions in accordance with ASME B16.5 for valves up to 24" nominal diameter.
- Hand-wheel, impact Hand-wheel, Chain-wheel, Gear operation, Electric, Pneumatic or Hydraulic Actuation as per Customer requirements.
- By-Pass, Lantern rings, grease injectors, special connections, etc.
- Low fugitive emissions control.
- NACE Service either MR-01-75 or MR-01-03.
- Test in accordance with API-598.
- Standard manufacturing flexible wedge from 2" and up

- ① Stem Nut, replaceable in line to avoid shut down of pipe line process.
- ② Rising stem with precision ACME single or double thread for quick operation. Surface finish suitable to seal properly to obtain low fugitive emissions.
- ③ Stem Packing is designed for optimum control of fugitive emissions leakage to the atmosphere. The ultra-low emission leakage rate is assured by the polished finish stem sealing area, the reduced diametrical clearances and the stem straightness control special designed packing. Live load packing arrangement available upon request.
- ④ Backseat, either threaded or welded designed to relieve back pressure on the stem packing when fully seated. Replacing stem packing under pressure is not recommended. Hard faced backseat available for severe service as per customer requirements.
- ⑤ Stem-Gate connection designed so that under severe applied loads (stuck gate), the stem will fail outside of the stuffing box pressure boundary.
- ⑥ Body to Bonnet ring type joint is designed to apply a uniform load to the gasket to assure a leak proof seal.
- ⑦ Seat rings are seal welded to provide a bubble tight joint.
- ⑧ Stellite Seat Rings provide increased resistance to wear, abrasion and erosion of the sealing surfaces.
- ⑨ Two pieces arrangement gland flange and stem packing bushing for self-alignment to avoid stem damage.
- ⑩ Gate valves supplied handwheel or gear operated.

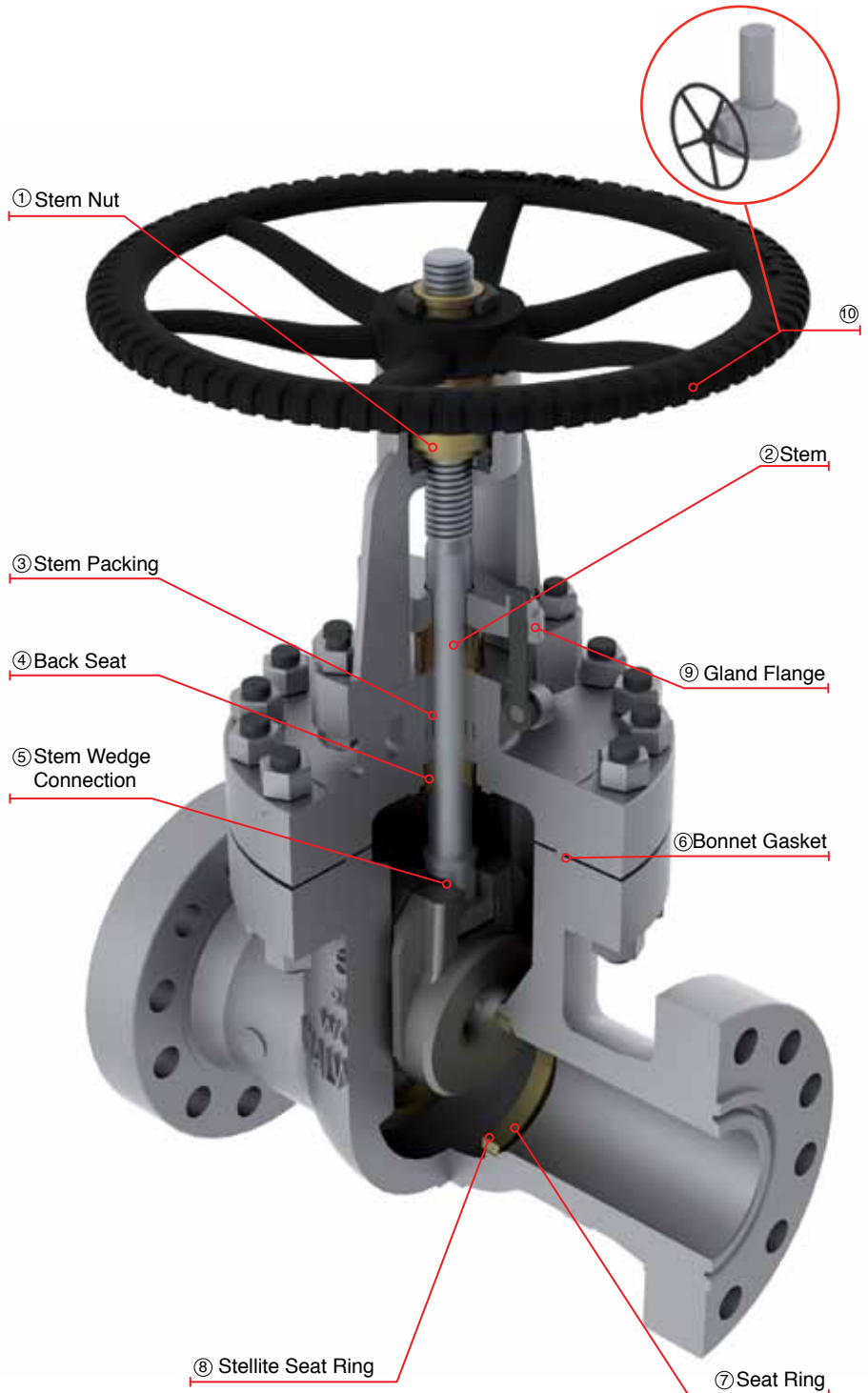

# WALWORTH CAST STEEL GATE VALVES, CLASS 900 (HANDWHEEL OPERATED)

- Design in accordance with API-600
- Outside Screw & Yoke (OS & Y)
- Flexible Wedge.
- Size 2" and 16" supplied with Handwheel as standard
- Flange dimensions as per ASME B16.5
- End to end dimensions as per ASME B16.10
- WE dimensions as per ASME B16.25
- Stem Nut with Bearing: 4" and larger

Catalog Figure No.	ID Plant Figure No.	Type of Ends
5247RF	5247F	Flanged Raised Face
5247RTJ	5247RJ	Flanged Ring Type Joint
5247WE	5247WE	Buttweld

## Regular Bill of Materials

No.	DESCRIPTION	WCB Trim UT
1	Body	ASTM A 216 GR WCB
2	Bonnet	ASTM A 216 GR WCB
3	Wedge	ASTM A 216 GR WCB + 13% Cr.
4	Seat Ring	ASTM A 515 GR 70 + ST6
5	Stem	ASTM A 276 Type 410
6	Yoke	ASTM A 216 GR WCB
7	Stem Nut Retainer	ASTM A 36
8	Grease Fitting	Commercial Steel
9	Stem Nut	UNS C95600 or Ni-Resist
10	Eyebolt / Gland Flange Studs	Alloy Steel
11	Eyebolt Nut	ASTM A 307
12	Gland Flange	ASTM A 515 GR 70
13	Packing Bushing	ASTM A 108 GR 1020
14	Eye Lug Bolt /Eyebolt pin	Alloy Steel
15	Stem Packing	Graphite
16	Bonnet Bushing	ASTM A 276 Type 410
17	Ring Type Joint Gasket	ASTM A 108 GR 1010
18	Bonnet Stud	ASTM A 193 GR B7
19	Bonnet Stud Nut	ASTM A 194 GR 2H
20	Handwheel	ASTM A 197
21	Handwheel Nut	ASTM A 108 GR 1020
22	Set Screw	Alloy Steel
23	Yoke Bolt	Alloy Steel
24	Yoke Bolt Nut	ASTM A 307
25	Stem Nut Bearing	Commercial Steel
*26	Stem Nut Oil Seal	Rubber/Commercial Steel
*27	Identification Plate	Stainless Steel

\*Not Shown

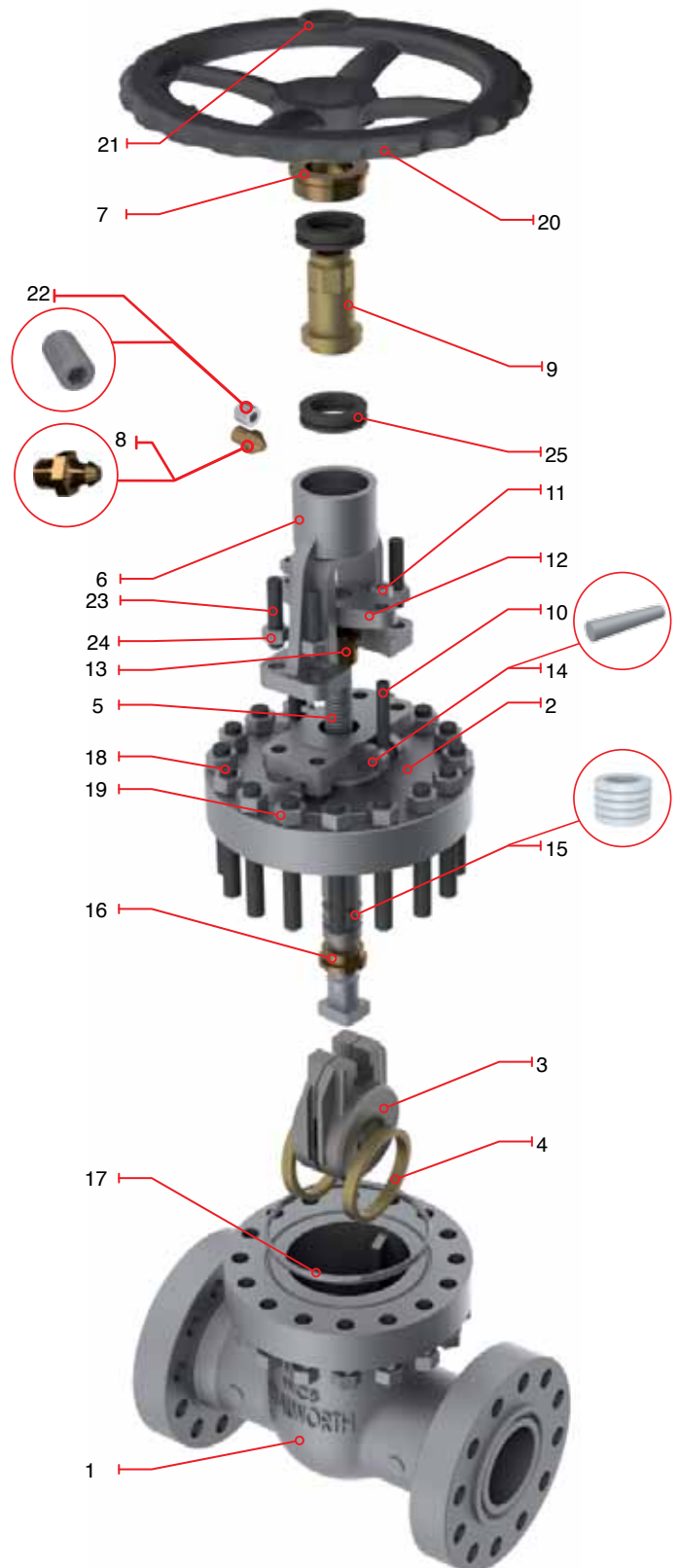

# WALWORTH CAST STEEL GATE VALVES, CLASS 900

## (HANDWHEEL OPERATED)



- Design in accordance with API-600
- Outside Screw & Yoke (OS & Y)
- Flexible Wedge
- Size 2" to 16" supplied with Handwheel as standard
- Flange dimensions as per ASME B16.5
- End to end dimensions as per ASME B16.10
- WE dimensions as per ASME B16.25
- Stem Nut with Bearing: 4" and larger

Catalog Figure No.	ID Plant Figure No.	Type of Ends
5247RF	5247F	Flanged Raised Face
5247RTJ	5247RJ	Flanged Ring Type Joint
5247WE	5247WE	Buttweld

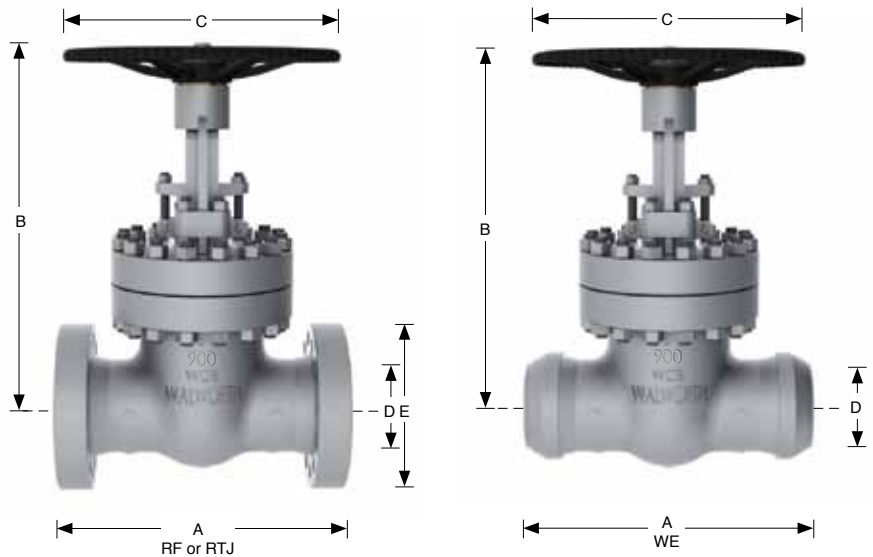

### Dimensions and Weights

D		76	102	127	152	203	254	305	356	406
Nominal Diameter	mm.	3	4	5	6	8	10	12	14	16
A	mm.	381	457	559	610	737	838	965	1029	1130
	inch	15	18	22	24	29	33	38	40 1/2	44 1/2
A	mm.	384	460	562	613	740	841	968	1038	1140
	inch	15 1/8	18 1/8	22 1/8	24 1/8	29 1/8	33 1/8	38 1/8	40 7/8	44 7/8
B	mm.	578	641	829	970	1127	1365	1727	1972	2197
	inch	22 3/4	25 1/4	32 5/8	38 3/16	44 3/8	53 3/4	68	77 5/8	86 1/2
C	mm.	406	457	508	508	610	660	914	914	914
	inch	16	18	20	20	24	26	36	36	36
E	mm.	241	292	349	381	470	546	610	641	705
	inch.	9 1/2	11 1/2	13 3/4	15	18 1/2	21 1/2	24	25 1/4	27 3/4
Weight 5247 RF/RTJ	kg.	106.5	153	367	352	542	905	1385	2778	3459
	lb.	212	336.6	807.4	774.4	1192.4	1991	3047	6111.6	7609.8
Weight 5247 WE	kg	95	136	327	313	482	805	1233	2472	3079
	lb.	209	300	719	689	1061	1772	2712	5439	6773

# WALWORTH CAST STEEL GATE VALVES, CLASS 900 (GEAR OPERATED)

- Design in accordance with API-600
- Outside Screw & Yoke (OS & Y)
- Flexible Wedge
- Size 18" to 24" supplied with Gear operator as standard
- Flange dimensions as per ASME B16.5
- End to end dimensions as per ASME B16.10
- WE dimensions as per ASME B16.25
- Stem Nut with Bearing: 4" and larger

Catalog Figure No.	ID Plant Figure No.	Type of Ends
5247RF	5247F	Flanged Raised Face
5247RTJ	5247RJ	Flanged Ring Type Joint
5247WE	5247WE	Buttweld

## Regular Bill of Materials

No.	DESCRIPTION	WCB Trim UT
1	Body	ASTM A 216 GR WCB
2	Bonnet	ASTM A 216 GR WCB
3	Wedge	ASTM A 216 GR WCB + 13% Cr.
4	Seat Ring	ASTM A 515 GR 70 + ST6
5	Stem	ASTM A 276 Type 410
6	Yoke	ASTM A 216 GR WCB
7	Stem Nut Retainer	ASTM A 36
8	Stem Nut	ASTM B 148 UNS C95600
9	Eyebolt / Gland Flange Studs	Alloy Steel
10	Eyebolt Nut	ASTM A 307
11	Gland Flange	ASTM A 515 GR 70
12	Packing Bushing	ASTM A 108 GR 1020
13	Eye Lug Bolt / Eye Bolt Pin	Alloy Steel
14	Stem Packing	Graphite
15	Bonnet Bushing	ASTM A 276 Type 410
16	Ring Type Joint Gasket	ASTM A 108 GR 1010
17	Bonnet Stud	ASTM A 193 GR B7
18	Bonnet Stud Nut	ASTM A 194 GR 2H
19	Gear Operator	as customer requirements
20	Operator Bolts	Alloy Steel
21	Yoke Bolts	Alloy Steel
*22	Yoke Bolt Nut	ASTM A 307
*23	Identification Plate	Stainless Steel

\*Not Shown

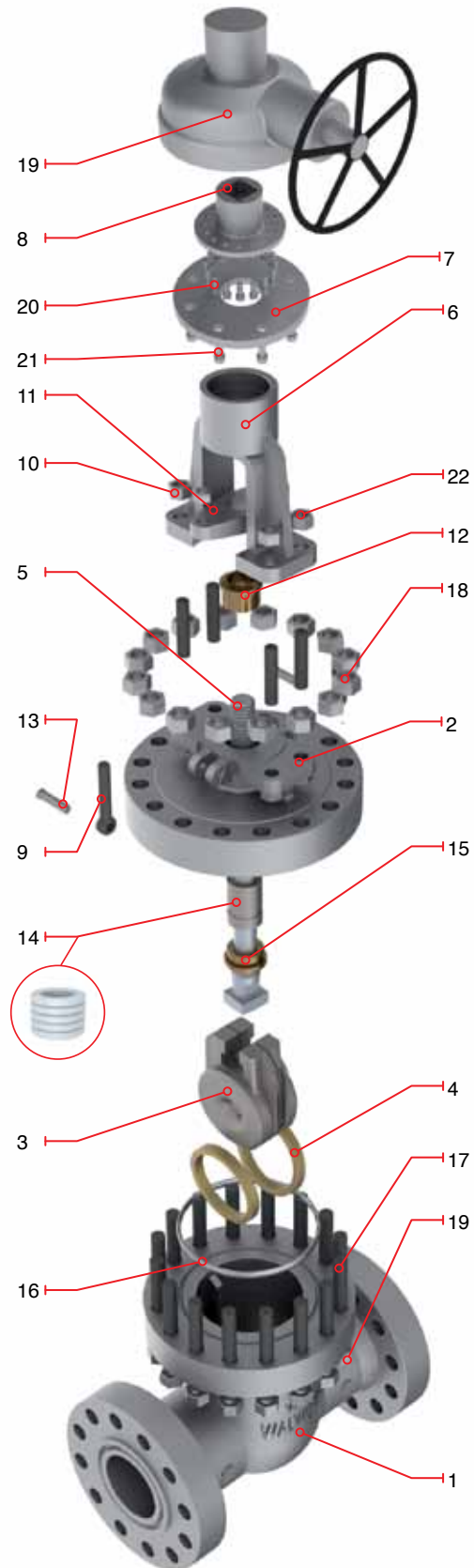

# WALWORTH CAST STEEL GATE VALVES, CLASS 900 (GEAR OPERATED)

- Design in accordance with API-600
- Outside Screw & Yoke (OS & Y)
- Flexible Wedge
- Size 18" to 24" supplied with Gear operator as standard
- Flange dimensions as per ASME B16.5
- End to end dimensions as per ASME B16.10
- WE dimensions as per ASME B16.25
- Stem Nut with Bearing: 4" and larger

Catalog Figure No.	ID Plant Figure No.	Type of Ends
5247RF	5247F	Flanged Raised Face
5247RTJ	5247RJ	Flanged Ring Type Joint
5247WE	5247WE	Buttweld

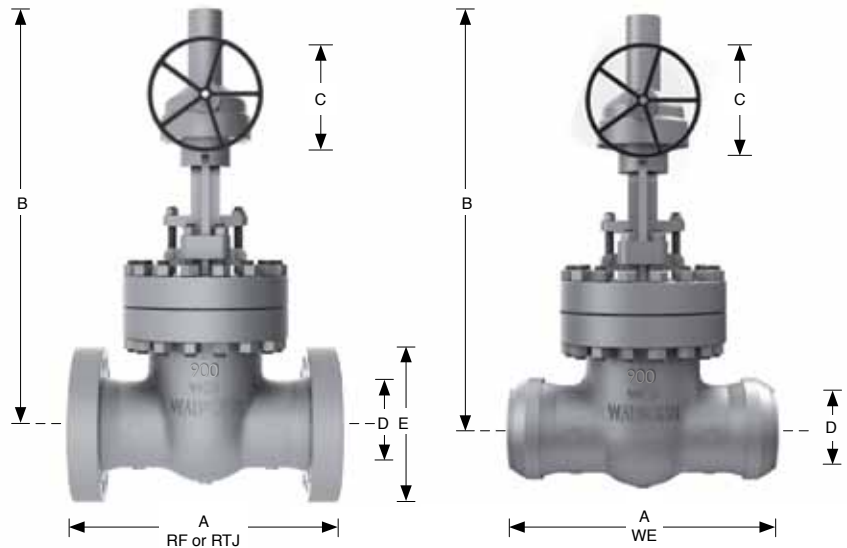
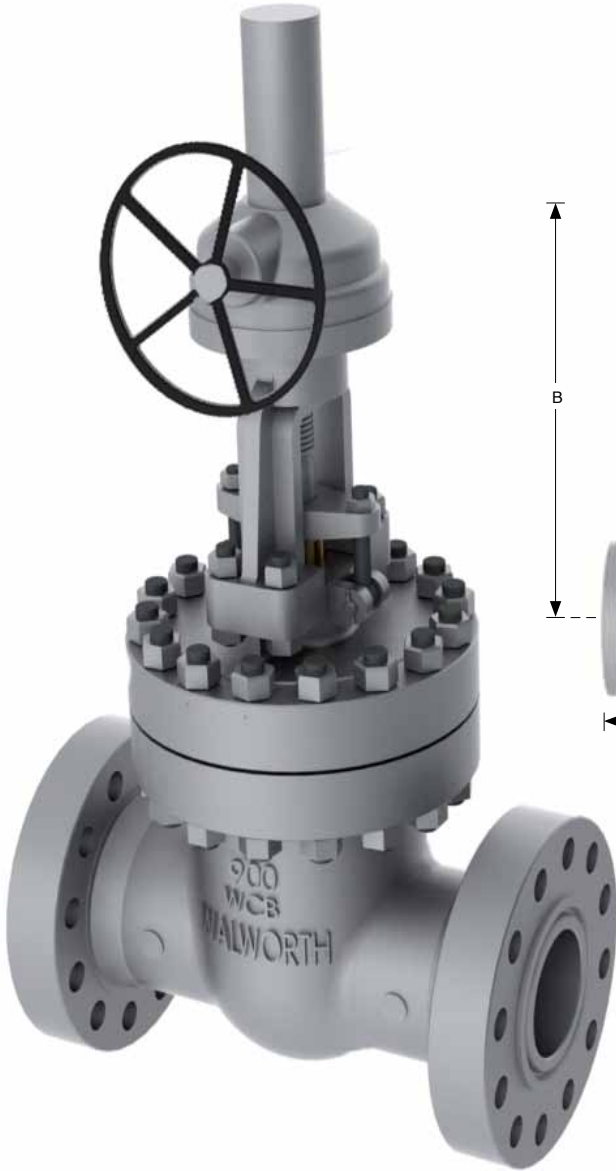

## Dimensions and Weights

D		457	508	610
Nominal	mm.	457	508	610
Diameter	inch	18	20	24
A	mm.	1219	1321	1549
	inch	48	52	61
A (RTJ)	mm.	1232	1334	1568
	inch	48.5	52.5	61.75
B	mm.	2057	2286	2743
	inch	81	90	108
C	mm.	762	762	762
	inch	30	30	30
E	mm.	787	857	1041
	inch.	31	33 3/4	41
Weight 5247RF/RTJ	kg.	4370	6300	8410
	lb.	9614	13860	18502
Weight 5247WE	kg	3889	5607	7485
	lb.	8556	12335	16467

# WALWORTH CAST STEEL GATE VALVES CLASS 1500

CAST STEEL GATE VALVES HANDWHEEL OR GEAR OPERATED, WITH RISING STEM AND OUT SIDE SCREW AND YOKE (OS&Y)

## DESIGN FEATURES

- Gate valves design in accordance with API-600, solid, flexible or parallel slide wedge/Disc.
- Gate valves option in accordance with API-603 only for stainless steel & nickel alloys.
- Gate and Globe valves for Cryogenic service with gas column in accordance with BS-6364 upon request.
- Flange dimensions in accordance with ASME B16.5 for valves up to 24" nominal diameter.
- Hand-wheel, impact Hand-wheel, Chain-wheel, Gear operation, Electric, Pneumatic or Hydraulic Actuation as per Customer requirements.
- By-Pass, Lantern rings, grease injectors, special connections, etc.
- Low fugitive emissions control.
- NACE Service either MR-01-75 or MR-01-03.
- Test in accordance with API-598.
- Standard manufacturing flexible wedge from 2" and up

- ① Stem Nut, replaceable in line to avoid shut down of pipe line process.
- ② Rising stem with precision ACME single or double thread for quick operation. Surface finish suitable to seal properly to obtain low fugitive emissions.
- ③ Stem Packing is designed for optimum control of fugitive emissions leakage to the atmosphere. The ultra-low emission leakage rate is assured by the polished finish stem sealing area, the reduced diametrical clearances and the stem straightness control special designed packing. Live load packing arrangement available upon request.
- ④ Backseat, either threaded or welded designed to relieve back pressure on the stem packing when fully seated. Replacing stem packing under pressure is not recommended. Hard faced backseat available for severe service as per customer requirements.
- ⑤ Stem-Gate connection designed so that under severe applied loads (stuck gate), the stem will fail outside of the stuffing box pressure boundary.
- ⑥ Body to Bonnet ring type joint is designed to apply a uniform load to the gasket to assure a leak proof seal.
- ⑦ Seat rings are seal welded to provide a bubble tight joint.
- ⑧ Stellite Seat Rings provide increased resistance to wear, abrasion and erosion of the sealing surfaces.
- ⑨ Two pieces arrangement gland flange and stem packing bushing for self-alignment to avoid stem damage.
- ⑩ Gate valves supplied handwheel or gear operated.

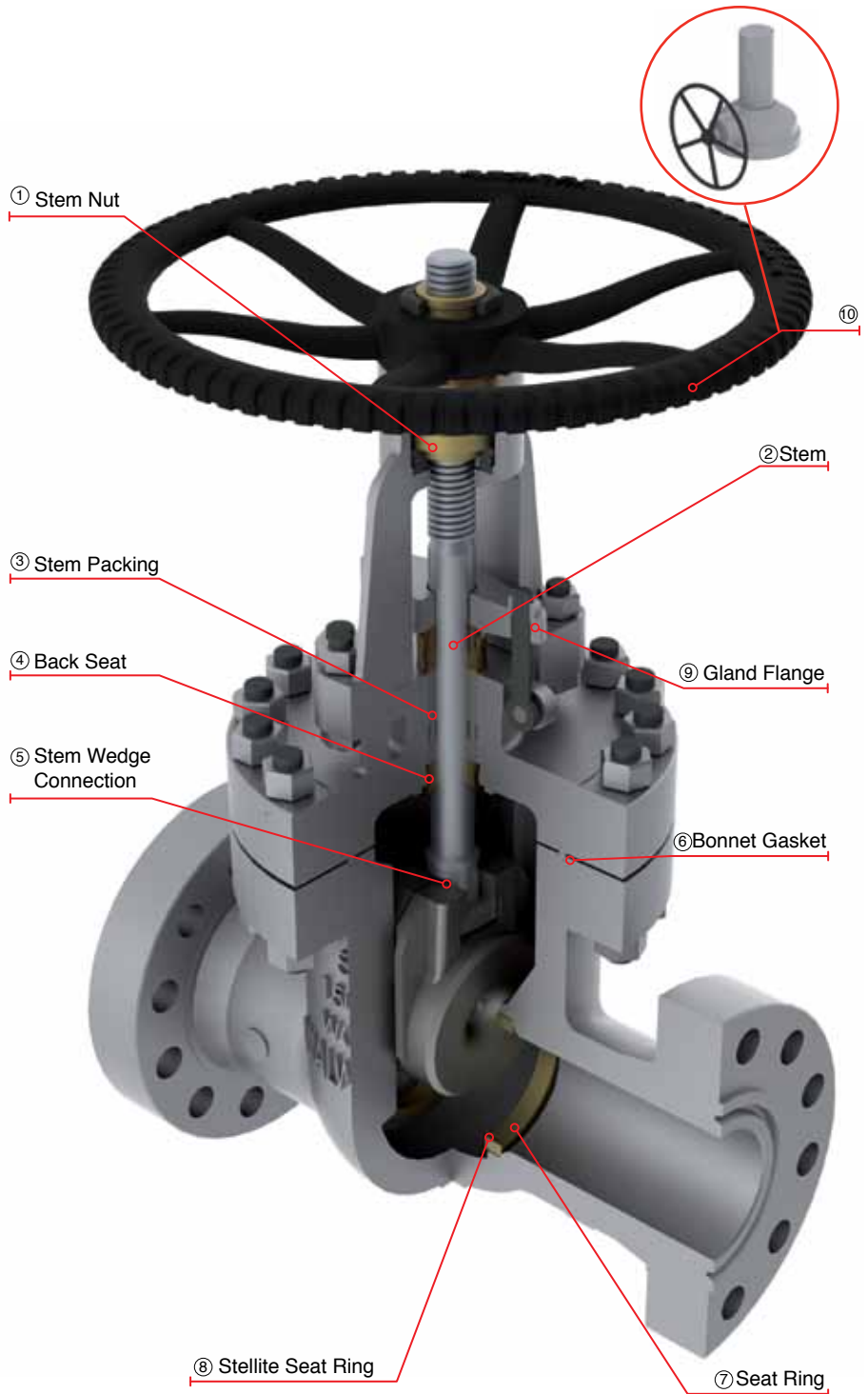

# WALWORTH CAST STEEL GATE VALVES, CLASS 1500 (HANDWHEEL OPERATED)

- Design in accordance with API-600
- Outside Screw & Yoke (OS & Y)
- Flexible Wedge
- Stem Nut with bearings -Size 4" and larger
- Size 2" to 16" Normally Supplied with Handwheel as standard
- Flange dimensions as per ASME B16.5
- End to end dimensions as per ASME B16.10
- WE dimensions as per ASME B16.25

Catalog Figure No.	ID Plant Figure No.	Type of Ends
5262RF	5262F	Flanged Raised Face
5262RTJ	5262RJ	Flanged Ring Type Joint
5262WE	5262WE	Buttweld

## Regular Bill of Materials

No.	DESCRIPTION	WCB Trim UT
1	Body	ASTM A 216 GR WCB
2	Bonnet	ASTM A 216 GR WCB
3	Wedge	ASTM A 216 GR WCB + 13% Cr.
4	Seat Ring	ASTM A 515 GR 70 + ST6
5	Stem	ASTM A 276 Type 410
6	Yoke	ASTM A 216 GR WCB
7	Stem Nut Retainer	ASTM A 36
8	Grease Fitting	Commercial Steel
9	Stem Nut	UNS C95600 or Ni-Resist
10	Eyebolt / Gland Flange Studs	Alloy Steel
11	Eyebolt Nut	ASTM A 307
12	Gland Flange	ASTM A 515 GR 70
13	Packing Bushing	ASTM A 108 GR 1020
14	Eye Lug Bolt / Eye Bolt Pin	Alloy Steel
15	Stem Packing	Graphite
16	Bonnet Bushing	ASTM A 276 Type 410
17	Ring Type Joint Gasket	ASTM A 108 GR 1010
18	Bonnet Stud	ASTM A 193 GR B7
19	Bonnet Stud Nut	ASTM A 194 GR 2H
20	Handwheel	ASTM A 197
21	Handwheel Nut	ASTM A 108 GR 1020
22	Set Screw	Alloy Steel
23	Yoke Bolt	Alloy Steel
24	Yoke Bolt Nut	ASTM A 307
25	Stem Nut Bearing	Commercial Steel
*26	Stem Nut Oil Seal	Rubber/Commercial Steel
*27	Identification Plate	Stainless Steel

\*Not Shown

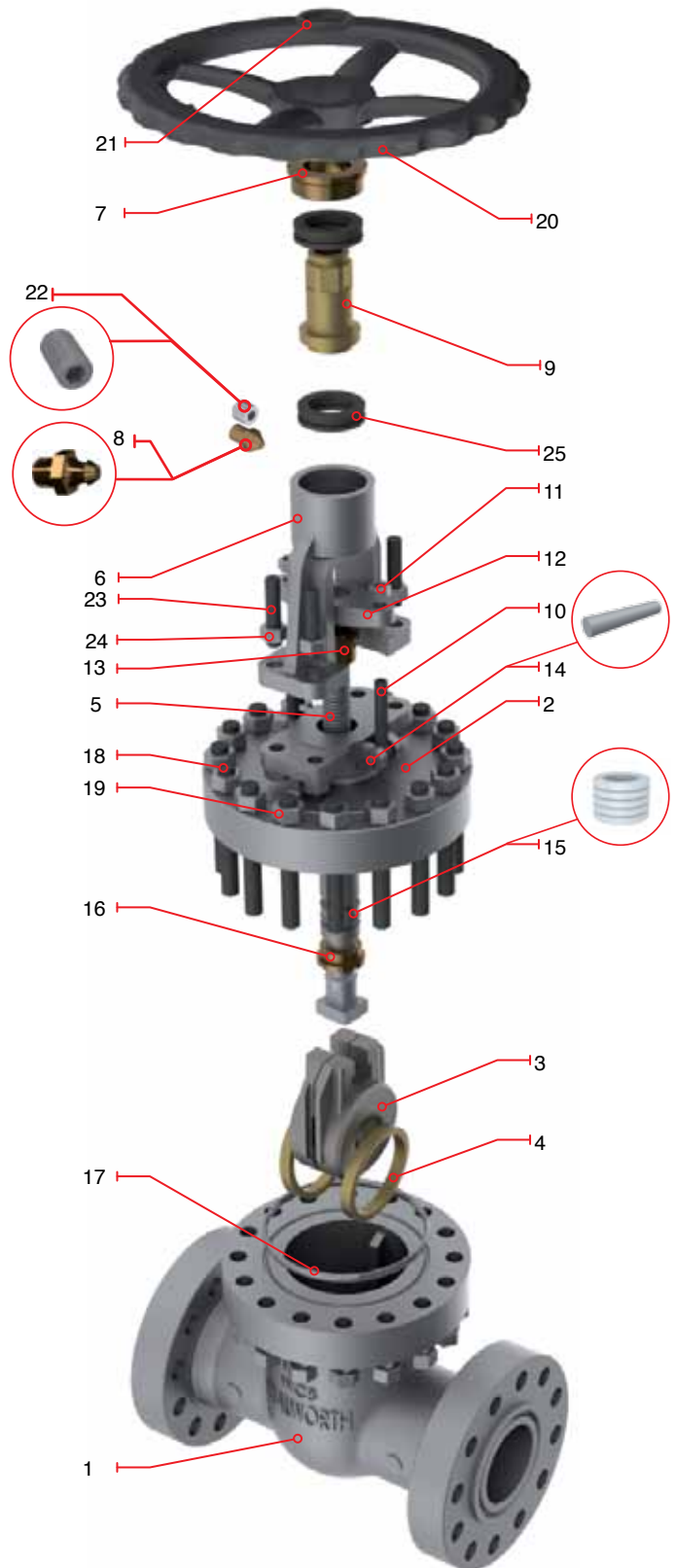



# WALWORTH CAST STEEL GATE VALVES, CLASS 1500 (HANDWHEEL OPERATED)



- Design in accordance with API-600
- Outside Screw & Yoke (OS & Y)
- Flexible Wedge
- Stem Nut with bearings: 4" and larger
- Size 2" to 16" Supplied with Handwheel as standard
- Flange dimensions as per ASME B16.5
- End to end dimensions as per ASME B16.10
- WE dimensions as per ASME B16.25

Catalog Figure No.	ID Plant Figure No.	Type of Ends
5262RF	5262F	Flanged Raised Face
5262RTJ	5262RJ	Flanged Ring Type Joint
5262WE	5262WE	Buttweld

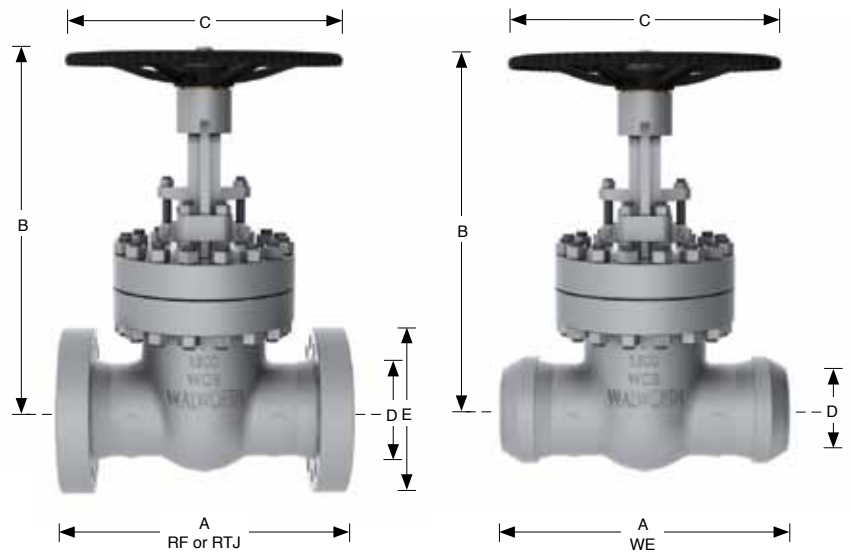

## Dimensions and Weights

D			51	64	76	102	127	152	203	254	305	356	406
Nominal Diameter	mm.	inch	2	2 1/2	3	4	5	6	8	10	12	14	16
A (RF y WE)	mm.	inch	368 14 1/2	419 16 1/2	470 18 1/2	546 21 1/2	673 26 1/2	705 27 3/4	832 32 3/4	991 39	1130 44 1/2	1257 49 1/2	1384 54 1/2
	mm.	inch	371 14 5/8	422 16 5/8	473 18 5/8	549 21 5/8	676 26 5/8	711 28	842 33 1/8	1000 39 3/8	1146 45 1/8	1276 50 1/4	1407 55 3/8
B	mm.	inch	591 23 1/4	699 27 1/2	876 34 1/2	994 39 1/8	1080 42 1/2	1191 46 7/8	1435 56 1/2	1740 68 1/2	2054 80 7/8	2172 85 1/2	2254 88 3/4
	mm.	inch	356 14	406 16	457 18	508 20	559 22	559 22	660 26	914 36	914 36	914 36	914 36
E	mm.	inch.	216 8 1/2	244 9 5/8	267 10 1/2	311 12 1/4	375 14 3/4	394 15 1/2	483 19	584 23	673 26 1/2	749 29 1/2	826 32 1/2
	Weight	kg.	78.5	99	140	209	510	523	893	2010	3080	4480	5110
5262RF/RTJ	lb.		173	218	308	460	1122	1151	1965	4422	6776	9856	11242
Weight	kg		93	130	245	319	493	635	1251	2000	2974	3990	5110
	lb.		205	286	539	702	1085	1397	2752	4400	6543	8778	11242

# WALWORTH CAST STEEL GATE VALVES. CLASS 1500 (GEAR OPERATED)

- Design in accordance with API-600
- Outside Screw & Yoke (OS & Y)
- Flexible Wedge.
- Size 18" to 24" Normally Supplied with gear box
- Flange dimensions as per ASME B16.5
- End to end dimensions as per ASME B16.10
- WE dimensions as per ASME B16.25
- Stem Nut with bearings: Size 4" and larger

Catalog Figure No.	ID Plant Figure No.	Type of Ends
5262RF	5262F	Flanged Raised Face
5262RTJ	5262RJ	Flanged Ring Type Joint
5262WE	5262WE	Buttweld

## Regular Bill of Materials

No.	DESCRIPTION	WCB Trim UT
1	Body	ASTM A 216 GR WCB
2	Bonnet	ASTM A 216 GR WCB
3	Wedge	ASTM A 216 GR WCB + 13% Cr.
4	Seat Ring	ASTM A 515 GR 70 + ST6
5	Stem	ASTM A 276 Type 410
6	Yoke	ASTM A 216 GR WCB
7	Stem Nut Retainer	ASTM A 36
8	Stem Nut	ASTM B 148 UNS C95600
9	Eyebolt /Gland Flange Studs	Alloy Steel
10	Eyebolt Nut	ASTM A 307
11	Gland Flange	ASTM A 515 GR 70
12	Packing Bushing	ASTM A 108 GR 1020
13	Eye Lug Bolt / Eye Bolt Pin	Alloy Steel
14	Stem Packing	Graphite
15	Bonnet Bushing	ASTM A 276 Type 410
16	Ring Type Joint Gasket	ASTM A 108 GR 1010
17	Bonnet Stud	ASTM A 193 GR B7
18	Bonnet Stud Nut	ASTM A 194 GR 2H
19	Gear Operator	as customer requirements
20	Operator Bolts	Alloy Steel
21	Yoke Bolts	Alloy Steel
*22	Yoke Bolt Nut	ASTM A 307
*23	Identification Plate	Stainless Steel

\*Not Shown

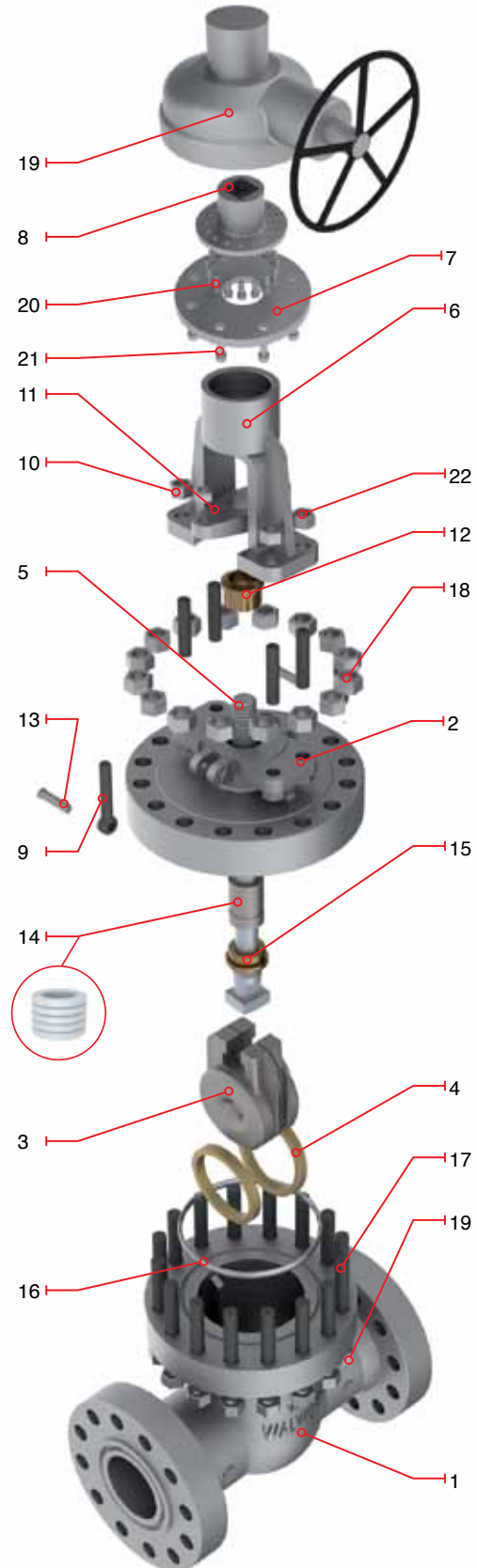

# WALWORTH CAST STEEL GATE VALVES, CLASS 1500 (GEAR OPERATED)

- Design in accordance with API-600
- Outside Screw & Yoke (OS & Y)
- Flexible Wedge
- Size 18" to 24" Normally Supplied with gear box
- Flange dimensions as per ASME B16.5
- End to end dimensions as per ASME B16.10
- WE dimensions as per ASME B16.25
- Stem Nut with bearings: Size 4" and larger

Catalog Figure No.	ID Plant Figure No.	Type of Ends
5262RF	5262F	Flanged Raised Face
5262RTJ	5262RJ	Flanged Ring Type Joint
5262WE	5262WE	Buttweld

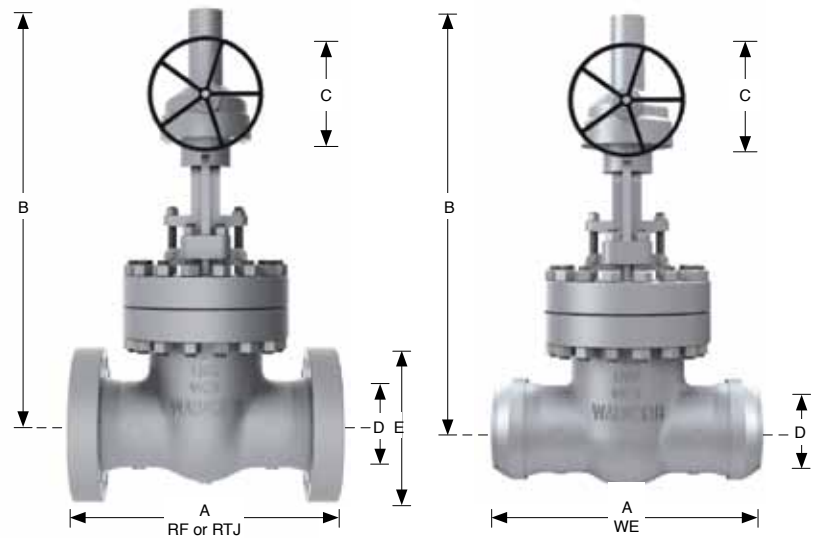

## Dimensions and Weights

D		mm.	457	508	610
Nominal Diameter		inch	18	20	24
A	mm.	1537	1664	1943	
	(RF y WE) inch	60 1/2	65 1/2	76 1/2	
A	mm.	1559	1686	1972	
	(RTJ) inch	61 3/8	66 3/8	77 5/8	
B	mm.	2057	2286	2743	
	inch	81	90	108	
C	mm.	762	762	762	
	inch	30	30	30	
E	mm.	914	984	1168	
	inch.	36	38 3/4	46	
Weight	kg.	7105	9000	11500	
	5262RF lb.	15631	19800	25300	
Weight	kg	5969	8100	10350	
	5262WE lb.	13132	17820	22770	

# WALWORTH CAST STEEL GLOBE VALVES CLASS 150

CAST STEEL GLOBE VALVES WITH RISING HANDWHEEL AND STEM.

## DESIGN FEATURES

- Globe valves design in accordance with ASME B16.34
- Globe valves option in accordance with API-603 only for stainless steel & nickel alloys.
- Gate & globe valves for cryogenic service with gas column in accordance with BS-6364 upon request
- Flange dimensions in accordance with ASME B16.5 for valves up to 24" nominal diameter
- Handwheel, handwheel impact, chain wheel, gear operation, electric, pneumatic or hydraulic actuation as per customer requirements
- By-pass, lantern rings, grease injectors, special connections, etc.
- Low fugitive emissions control
- NACE service either MR-01-75 or MR-01-03.
- Test in accordance with API-598
- Stop check design option available

① Stem Nut, replaceable in line to avoid shut down of pipe line process.

② Revolving rising stem with precision ACME single or double thread for quick operation. Surface finish suitable to seal properly to get low fugitive emissions.

③ Stem Packing is designed for optimum control of fugitive emissions leakage to the atmosphere. The ultra low emission leakage rate is assured by the fine finish in the stem, the reduced diametrical clearances and the stem straightness control special designed packing. Live load packing arrangement available upon request.

④ Backseat either threaded or welded, designed to relieve back pressure on the stem packing when fully seated. Replacing stem packing under pressure is not recommended. Hard faced backseat available for severe service as customer requirements

⑤ Body to Bonnet Joint designed to apply a uniform load to the gasket to assure a leak proof seal.

⑥ Conical Plug Type Disc, integrally guided to assure true alignment between disc and valve body. The loose disc design allows the disc and seat ring sealing surface to seat correctly without damage.

⑦ Stellited Seat Ring is seal welded to provide a increased resistance to wear, abrasion, and erosion of the sealing surfaces.

⑧ Two pieces arrangement gland flange and stem packing bushing for self-alignment to avoid stem damage.

⑨ Impact Handwheel, the mechanism is based on transmitting the momentum generated by the mass of the handwheel through the impact/impulse generated during the snap closure action of the handwheel. This type of handwheel is used when a standard handwheel cannot create enough closing force to effect a seal. Gear operated is also available.

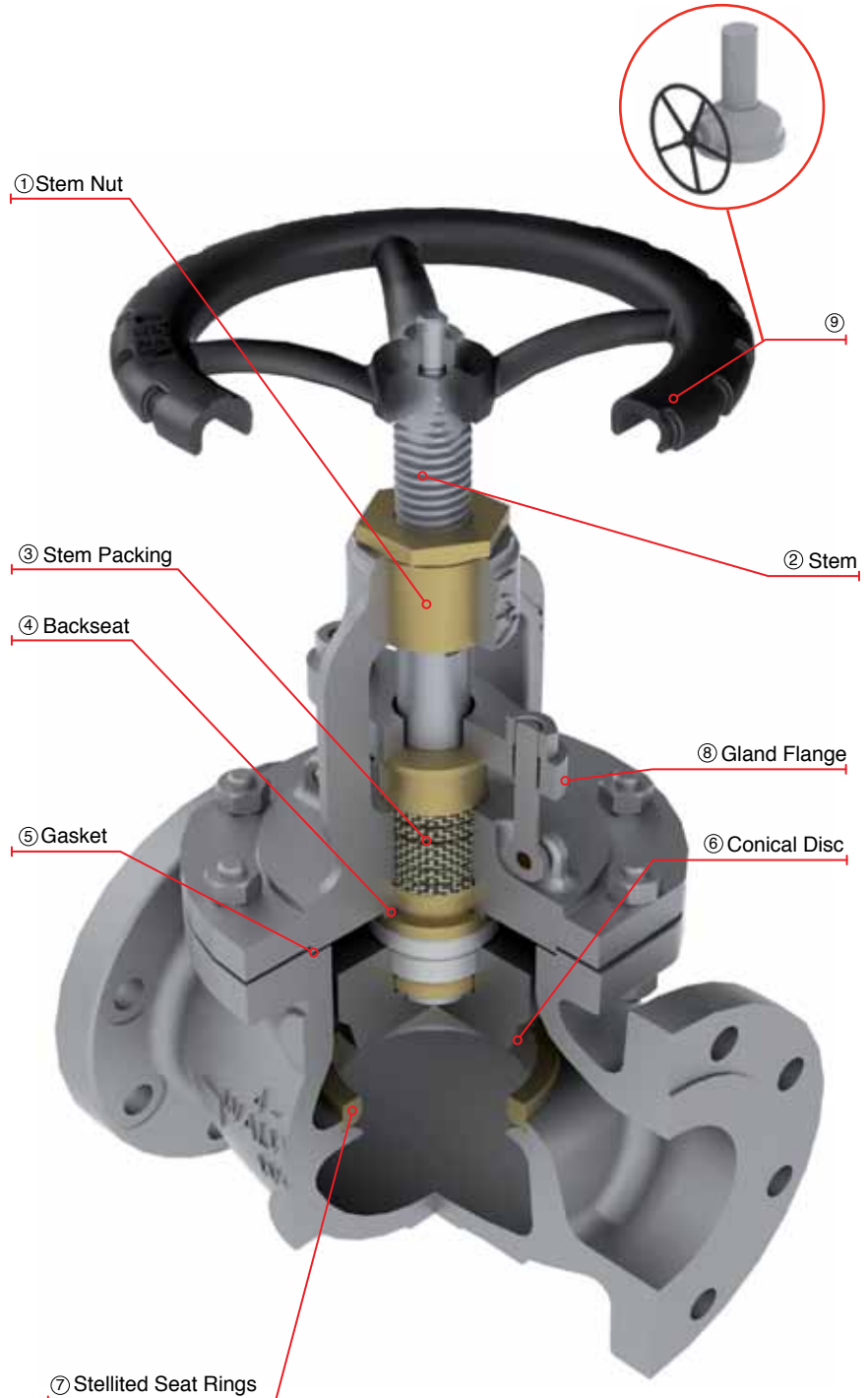

# WALWORTH CAST STEEL GLOBE VALVES, CLASS 150 (HANDWHEEL OPERATED)

- Design in accordance with ASME B 16.34
- Rising Stem and Handwheel
- Flange dimensions as per ASME B16.5
- End to end dimensions as per ASME B16.10
- WE dimensions as per ASME B 16.25
- Bonnet with Bearings: 14" and larger
- Size 2" to 12" Handwheel Operated as standard

Catalog Figure No.	ID Plant Figure No.	Type of Ends
5275RF	5275F	Flanged Raised Face
5275RTJ	5275RJ	Flanged Ring Type Joint
5275WE	5275WE	Buttweld

## Regular Bill of Materials

No.	DESCRIPTION	STANDAR MATERIAL
1	Body	ASTM A 216 GR WCB
2	Bonnet	ASTM A 216 GR WCB
3	Disc	ASTM A 276 Type 410
4	Disc Locknut	Alloy Steel
*5	Disc Washer	ASTM A 276 Type 410
6	Seat Ring	ASTM A 515 GR 70 + ST6
7	Stem	ASTM A 276 Type 410
8	Stem Nut	ASTM B 148 UNS C95600
9	Set Screw	Alloy Steel
10	Eyebolt	Alloy Steel
11	Eyebolt Nut	ASTM A 307
12	Gland Flange	ASTM A 515 GR 70
13	Packing Bushing	ASTM A 108 GR 1020
14	Eyebolt Pin	Alloy Steel
15	Bonnet Stud	ASTM A 193 GR B7
16	Bonnet Stud Nut	ASTM A 194 GR 2H
17	Bonnet Gasket	Graphite/Stainless Steel 316
18	Bonnet Bushing	ASTM A 276 Type 410
19	Stem Packing	Graphite
20	Handwheel	ASTM A 197
21	Handwheel Nut	ASTM A 307
*22	Handwheel Washer	Commercial Steel
*23	Identification Plate	Stainless Steel

\*Not shown

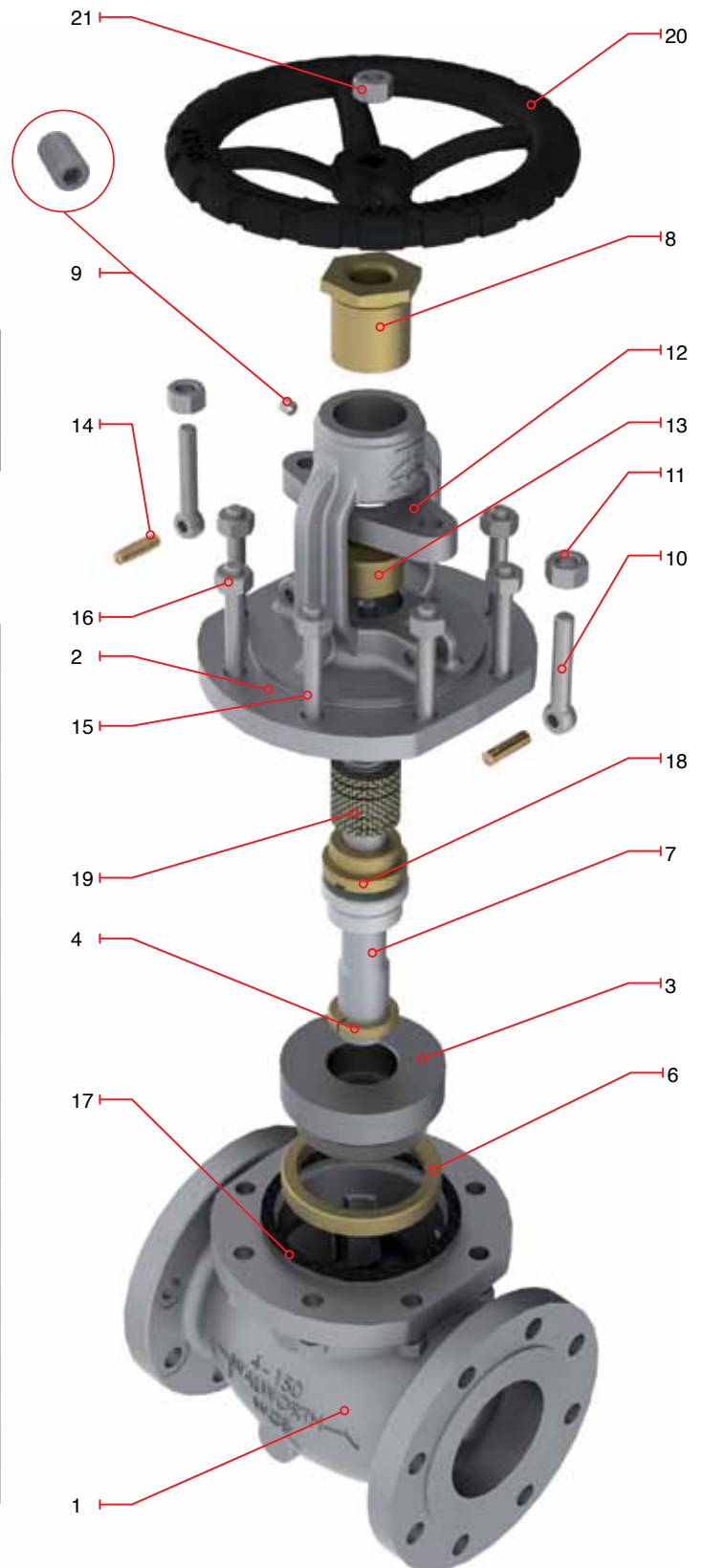

# WALWORTH CAST STEEL GLOBE VALVES, CLASS 150 (HANDWHEEL OPERATED)



- Design in accordance with ASME B 16.34
- Rising Stem and Handwheel 6" and smaller
- Rising stem and fixed handwheel 8" and up
- Flange dimensions as per ASME B16.5
- End to end dimensions as per ASME B16.10
- WE dimensions as per ASME B 16.25
- Bonnet with Bearings: 14" and larger
- Size 2" to 12" Handwheel Operated as standard

Catalog Figure No.	ID Plant Figure No.	Type of Ends
5275RF	5275F	Flanged Raised Face
5275RTJ	5275RJ	Flanged Ring Type Joint
5275WE	5275WE	Buttweld

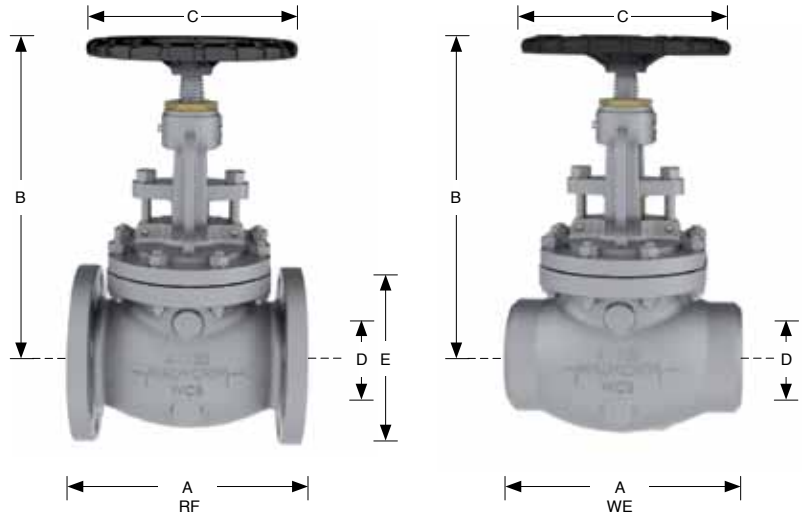

## Dimensions and Weights

D Nominal Diameter	mm. inch	51 2	64 2 1/2	76 3	102 4	127 5	152 6	203 8	254 10	305 12	356 14	406 16	457 18
A	mm.	203	216	241	292	406	495	622	699	787	914	978	978
(RF y WE)	inch	8	8 1/2	9 1/2	11 1/2	16	19 1/2	24 1/2	27 1/2	31	36	38 1/2	38 1/2
B	mm.	329	386	354	432	513	643	668	830	990	996	1327	1327
	inch	12 15/16	15 3/16	13 15/16	17	20 3/16	25 5/16	26 5/16	32 11/16	39	39 1/4	52 1/4	52 1/4
C	mm.	203	203	203	254	356	406	457	610	560	640	720	720
	inch	8	8	8	10	14	16	18	24	22	25	28	28
E	mm.	152	178	191	229	279	343	406	483	533	597	635	635
	inch.	6	7	7 1/2	9	11	13 1/2	16	19	21	23 1/2	25	25
Weight	kg.	18	29	34	55	100	186	267	399	530	678	998	998
5275RF	lb.	40	64	75	121	220	409	587	878	1166	1492	2196	2196
Weight	kg.	15	25	32	45	84	155	233	394	472	603	888	888
5275WE	lb.	33	55	70	99	185	341	513	867	1038	1328	1954	1954

For size and dimensions not shown, please contact our Sales Department.

# WALWORTH CAST STEEL GLOBE VALVES, CLASS 150 (GEAR OPERATED)

- Design in accordance with ASME B 16.34
- Rising Stem and Handwheel 6" and smaller
- Flange dimensions as per ASME B16.5
- End to end dimensions as per ASME B16.10
- WE dimensions as per ASME B 16.25
- Bonnet with Bearings: 14" and larger
- Size 2" to 12" Handwheel Operated as standard

Catalog Figure No.	ID Plant Figure No.	Type of Ends
5275RF	5275F	Flanged Raised Face
5275RTJ	5275RJ	Flanged Ring Type Joint
5275WE	5275WE	Buttweld

## Regular Bill of Materials

No.	DESCRIPTION	STANDAR MATERIAL
1	Body	ASTM A 216 GR WCB
2	Bonnet	ASTM A 216 GR WCB
3	Disc	ASTM A 276 Type 410
4	Disc Locknut	Alloy Steel
*5	Disc Washer	ASTM A 276 Type 410
6	Seat Ring	ASTM A 515 GR 70 + ST6
7	Stem	ASTM A 276 Type 410
8	Stem Nut	ASTM B 148 UNS C95600
9	Set Screw	Alloy Steel
10	Eyebolt	Alloy Steel
11	Eyebolt Nut	ASTM A 307
12	Gland Flange	ASTM A 515 GR 70
13	Packing Bushing	ASTM A 108 GR 1020
14	Eyebolt Pin	Alloy Steel
15	Bonnet Stud	ASTM A 193 GR B7
16	Bonnet Stud Nut	ASTM A 194 GR 2H
17	Bonnet Gasket	Graphite/Stainless Steel 316
18	Bonnet Bushing	ASTM A 276 Type 410
19	Stem Packing	Graphite
20	Gear Operator	as customer requirements
*21	Operator Bolts	Alloy Steel
*22	Identification Plate	Stainless Steel

\*Not shown

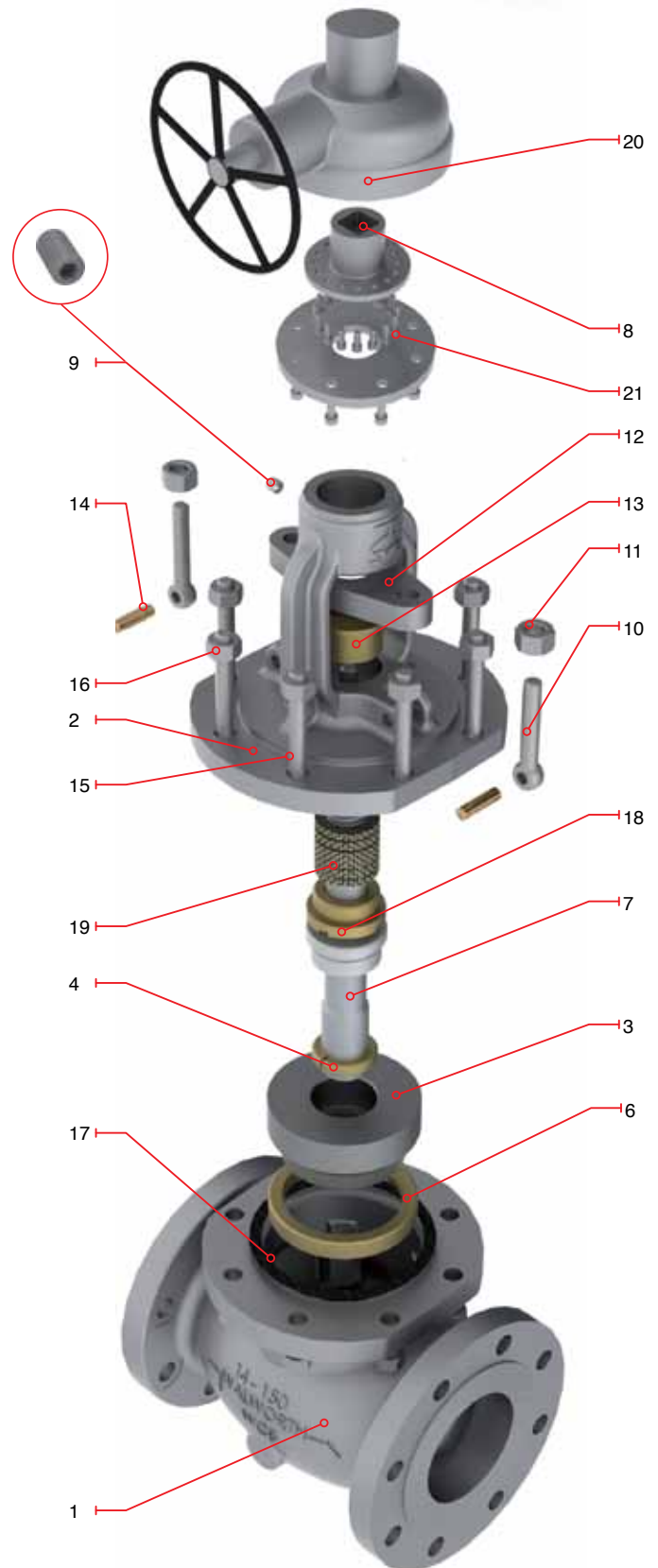

# WALWORTH CAST STEEL GLOBE VALVES, CLASS 150 (GEAR OPERATED)

- Design in accordance with ASME B 16.34
- Rising Stem and Handwheel 6" and smaller
- Flange dimensions as per ASME B16.5
- End to end dimensions as per ASME B16.10
- WE dimensions as per ASME B 16.25
- Bonnet with Bearings: 14" and larger
- Size 14" and up gear operated as standard

Catalog Figure No.	ID Plant Figure No.	Type of Ends
5275RF	5275F	Flanged Raised Face
5275RTJ	5275RJ	Flanged Ring Type Joint
5275WE	5275WE	Buttweld

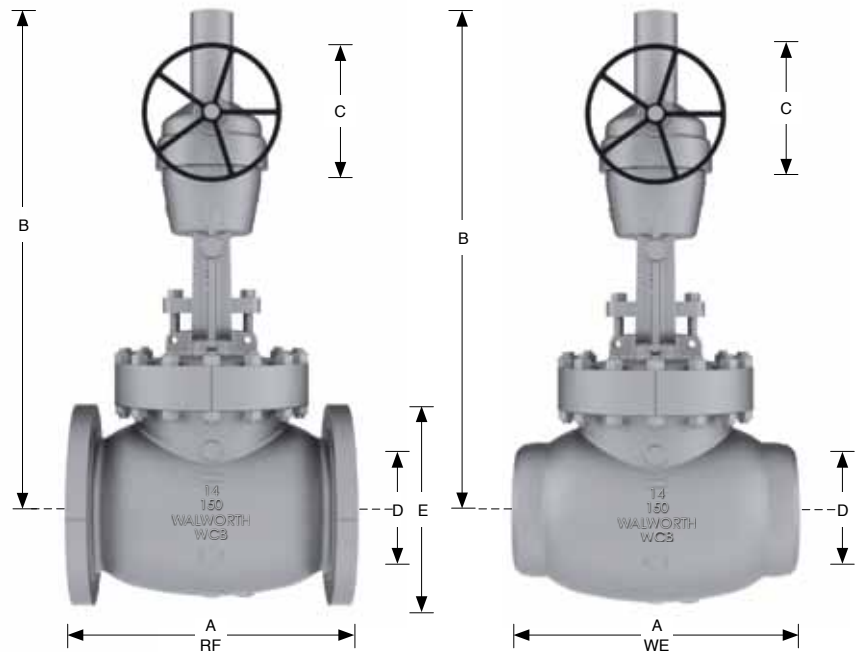

## Dimensions and Weights

D	Nominal Diameter	mm.	508	610
		inch	20	24
A	(RF y WE)	mm.	978	1295
		inch	38 1/2	51
B		mm.	1230	1500
		inch	48 3/8	59
C		mm.	530	600
		inch	21	23 1/2
E		mm.	699	813
		inch	27 1/2	32
Weight		mm.	1097	1613
5275RF		inch.	2413.4	3548.6
Weight		kg.	976	1436
5275WE		lb.	2148	3158

For size and dimensions not shown, please contact our Sales Department.



# WALWORTH CAST STEEL GLOBE VALVES CLASS 300

CAST STEEL GLOBE VALVES WITH RISING HANDWHEEL AND STEM.

## DESIGN FEATURES

- Globe valves design in accordance with ASME B16.34
- Globe valves option in accordance with API-603 only for stainless steel & nickel alloys.
- Gate & globe valves for cryogenic service with gas column in accordance with BS-6364 upon request
- Flange dimensions in accordance with ASME B16.5 for valves up to 24" nominal diameter
- Handwheel, handwheel impact, chain wheel, gear operation, electric, pneumatic or hydraulic actuation as per customer requirements
- By-pass, lantern rings, grease injectors, special connections, etc.
- Low fugitive emissions control
- NACE service either MR-01-75 or MR-01-03.
- Test in accordance with API-598
- Stop check design option available

- ① Stem Nut, replaceable in line to avoid shut down of pipe line process.
- ② Revolving rising stem with precision ACME single or double thread for quick operation. Surface finish suitable to seal properly to get low fugitive emissions.
- ③ Stem Packing is designed for optimum control of fugitive emissions leakage to the atmosphere. The ultra low emission leakage rate is assured by the fine finish in the stem, the reduced diametrical clearances and the stem straightness control special designed packing. Live load packing arrangement available upon request.
- ④ Backseat either threaded or welded, designed to relieve back pressure on the stem packing when fully seated. Replacing stem packing under pressure is not recommended. Hard faced backseat available for severe service as customer requirements
- ⑤ Body to Bonnet Joint designed to apply a uniform load to the gasket to assure a leak proof seal.
- ⑥ Conical Plug type Disc, integrally guided to assure true alignment between disc and valve body. The loose disc design allows the disc and seat ring sealing surface to seat correctly without damage.
- ⑦ Stellite Seat Ring is seal welded to provide a increased resistance to wear, abrasion, and erosion of the sealing surfaces.
- ⑧ Two pieces arrangement gland flange and stem packing bushing for self-alignment to avoid stem damage.
- ⑨ Impact Handwheel, the mechanism is based on transmitting the momentum generated by the mass of the handwheel through the impact/impulse generated during the snap closure action of the handwheel. This type of handwheel is used when a standard handwheel cannot create enough closing force to effect a seal. Gear operated is also available.

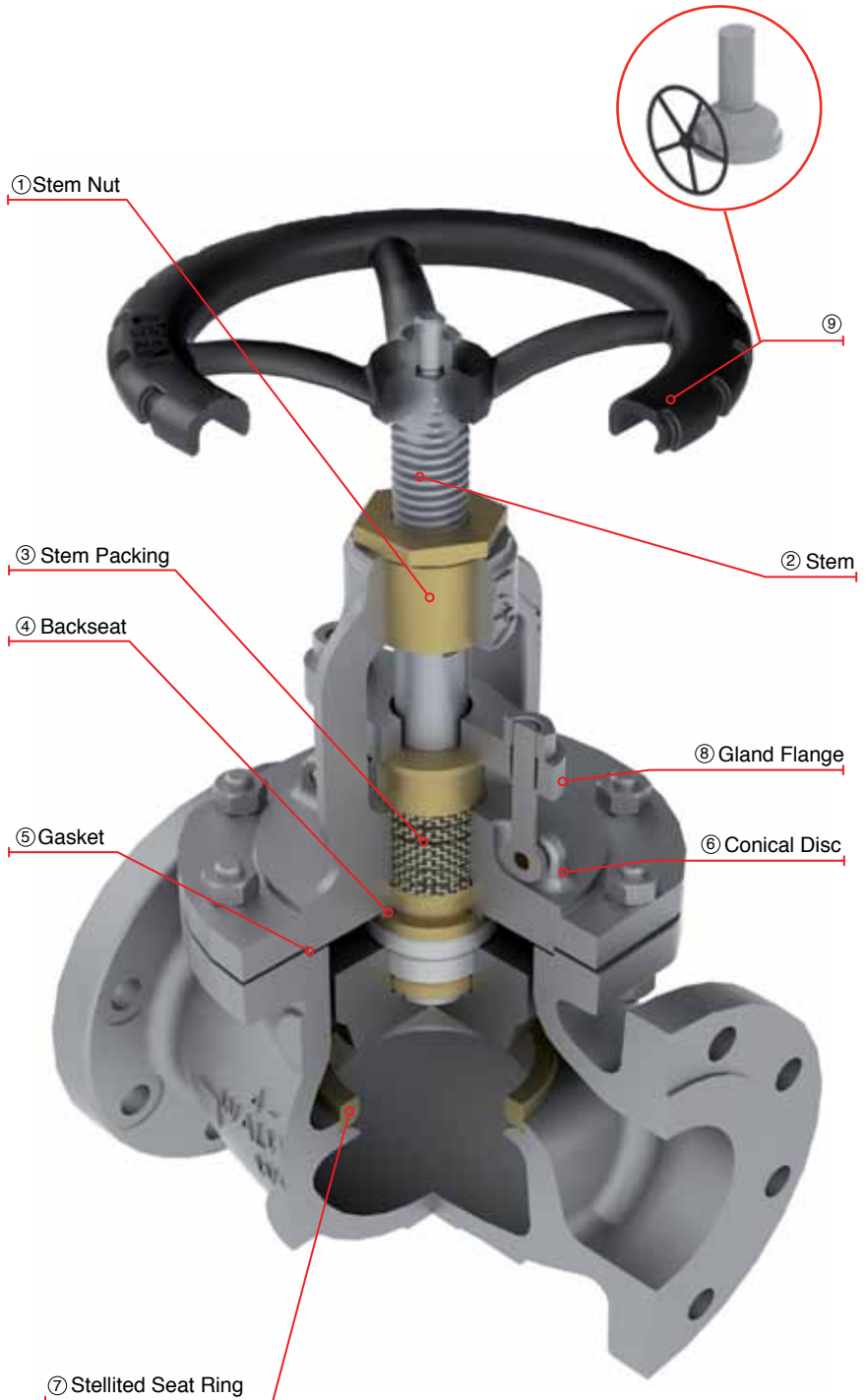

# WALWORTH CAST STEEL GLOBE VALVES, CLASS 300 (HANDWHEEL OPERATED)

- Design in accordance with ASME B 16.34
- Rising Stem and Handwheel: 6" and smaller
- Rising Stem and Fixed Handwheel: 8" and up
- Flange dimensions as per ASME B16.5
- End to end dimensions as per ASME B16.10
- WE dimensions as per ASME B 16.25
- Bonnet with Bearings: 8" and larger
- Size 2" to 12" Handwheel operated as standard

Catalog Figure No.	ID Plant Figure No.	Type of Ends
5281RF	5281F	Flanged Raised Face
5281RTJ	5281RJ	Flanged Ring Type Joint
5281WE	5281WE	Buttweld

## Regular Bill of Materials

No.	DESCRIPTION	STANDARD MATERIAL
1	Body	ASTM A 216 GR WCB
2	Bonnet	ASTM A 216 GR WCB
3	Disc	ASTM A 276 Type 410
4	Disc Lock Nut	Alloy Steel
*5	Disc Washer	ASTM A 276 Type 410
6	Seat Ring	ASTM A 515 GR 70 + ST6
7	Stem	ASTM A 276 Type 410
8	Stem Nut	ASTM B 148 UNS C95600
9	Screw	Alloy Steel
10	Eyebolt	Alloy Steel
11	Eyebolt Nut	ASTM A 307
12	Gland Flange	ASTM A 515 GR 70
13	Packing Bushing	ASTM A 108 GR 1020
14	Eyebolt Pin	Alloy Steel
15	Bonnet Stud	ASTM A 193 GR B7
16	Bonnet Stud Nut	ASTM A 194 GR 2H
17	Bonnet Gasket	Spiral Stainless 304/Graphite
18	Bonnet Bushing	ASTM A 276 Type 410
19	Stem Packing	Graphite
20	Handwheel	ASTM A 197
21	Handwheel Washer	Commercial Steel
22	Handwheel Nut	ASTM A 307
*23	Identification Plate	Stainless Steel

\*Not Shown

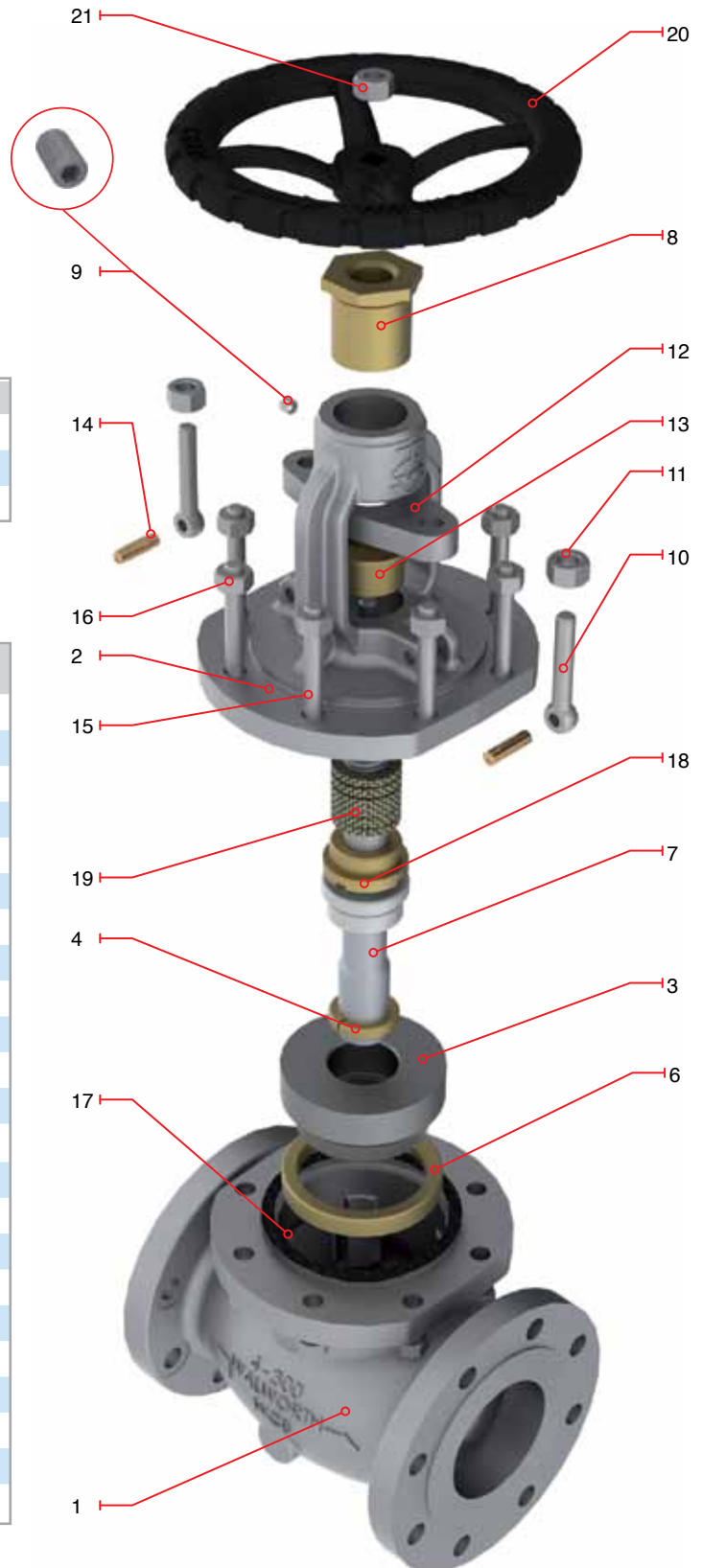

# WALWORTH CAST STEEL GLOBE VALVES, CLASS 300 (HANDWHEEL OPERATED)



- Design in accordance with ASME B 16.34
- Rising Stem and Handwheel: 6" and smaller
- Rising Stem and Fixed Handwheel: 8" and up
- Flange dimensions as per ASME B16.5
- End to end dimensions as per ASME B16.10
- WE dimensions as per ASME B 16.25
- Bonnet with Bearings: 8" and larger
- Size 2" to 12" Handwheel operated as standard

Catalog Figure No.	ID Plant Figure No.	Type of Ends
5281RF	5281F	Flanged Raised Face
5281RTJ	5281RJ	Flanged Ring Type Joint
5281WE	5281WE	Buttweld

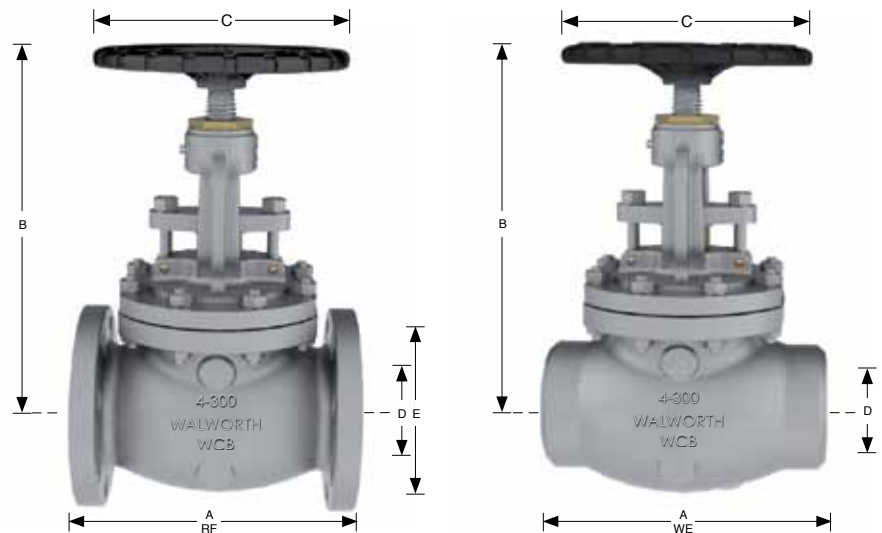

## Dimensions and Weights

D												
Nominal Diameter	mm.	51	64	76	102	152	203	254	305	356	406	
	inch.	2	2 1/2	3	4	6	8	10	12	14	16	
A (RF y WE)	mm.	267	292	318	356	445	559	622	711	838	864	
	inch	10 1/2	11 1/2	12 1/2	14	17 1/2	22	24 1/2	28	33	34	
B	mm.	360	505	418	511	621	854	1000	1180	1037	1173	
	inch	14 3/16	19 7/8	16 7/16	20 1/8	24 7/16	33 5/8	39 3/8	46 7/16	40 7/8	46 1/8	
C	mm.	203	254	254	356	457	610	762	965	640	640	
	inch	8	10	10	14	18	24	30	38	25	25	
E	mm.	165	191	210	254	318	381	445	521	584	648	
	inch.	6 1/2	7 1/2	8 1/4	10	12 1/2	15	17 1/2	20 1/2	23	25 1/2	
Weight 5281RF	kg.	26	43	50	78	154	294	461	675	787	1097	
	lb.	57.2	94.6	110	171.6	338.8	646.8	1014.2	1485	1731.4	2413.4	
Weight 5281WE	kg.	20	35	40	62	148	254	381	574	669	932	
	lb.	44	77	88	136	326	559	838	1262	1472	2051	

For size and dimensions not shown, please contact our Sales Department.

# WALWORTH CAST STEEL GLOBE VALVES, CLASS 300 (GEAR OPERATED)

- Design in accordance with ASME B 16.34
- Rising Stem
- Flange dimensions as per ASME B16.5
- End to end dimensions as per ASME B16.10
- WE dimensions as per ASME B 16.25
- Bonnet with Bearings: 8" and larger
- Size 14" and up Gear operated as standard

Catalog Figure No.	ID Plant Figure No.	Type of Ends
5281RF	5281F	Flanged Raised Face
5281RTJ	5281RJ	Flanged Ring Type Joint
5281WE	5281WE	Buttweld

## Regular Bill of Materials

No.	DESCRIPTION	STANDAR MATERIAL
1	Body	ASTM A 216 GR WCB
2	Bonnet	ASTM A 216 GR WCB
3	Disc	ASTM A 276 Type 410
4	Disc Locknut	Alloy Steel
*5	Disc Washer	ASTM A 276 Type 410
6	Seat Ring	ASTM A 515 GR 70 + ST6
7	Stem	ASTM A 276 Type 410
8	Stem Nut	ASTM B 148 UNS C95600
9	Set Screw	Alloy Steel
10	Eyebolt	Alloy Steel
11	Eyebolt Nut	ASTM A 307
12	Gland Flange	ASTM A 515 GR 70
13	Packing Bushing	ASTM A 108 GR 1020
14	Eyebolt Pin	Alloy Steel
15	Bonnet Stud	ASTM A 193 GR B7
16	Bonnet Stud Nut	ASTM A 194 GR 2H
17	Bonnet Gasket	Graphite/Stainless Steel 316
18	Bonnet Bushing	ASTM A 276 Type 410
19	Stem Packing	Graphite
20	Gear Operator	as customer requirements
21	Operator Bolts	Alloy Steel
*22	Identification Plate	Stainless Steel

\*Not Shown

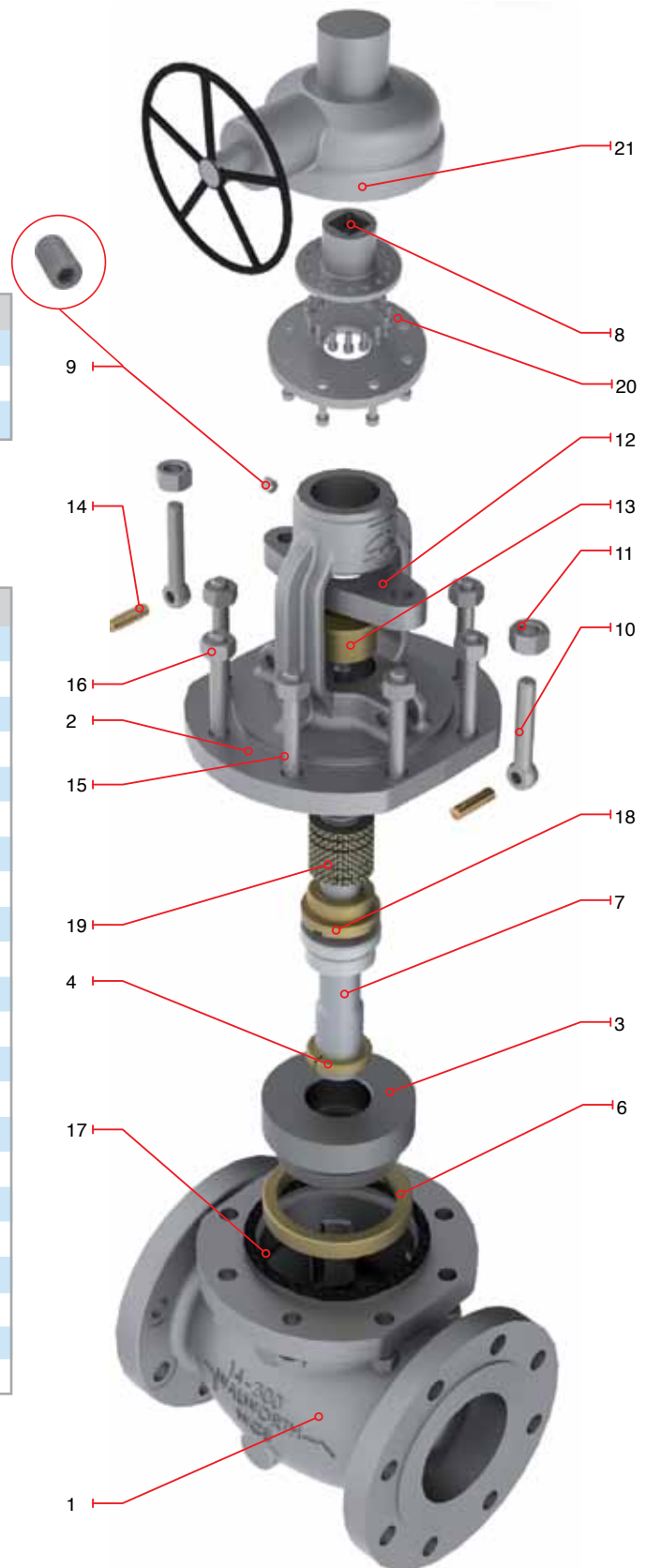

# WALWORTH CAST STEEL GLOBE VALVES, CLASS 300 (GEAR OPERATED)

- Design in accordance with ASME B 16.34
- Rising Stem
- Flange dimensions as per ASME B16.5
- End to end dimensions as per ASME B16.10
- WE dimensions as per ASME B 16.25
- Bonnet with Bearings: 8" and larger
- Size 14" and up Gear operated as standard

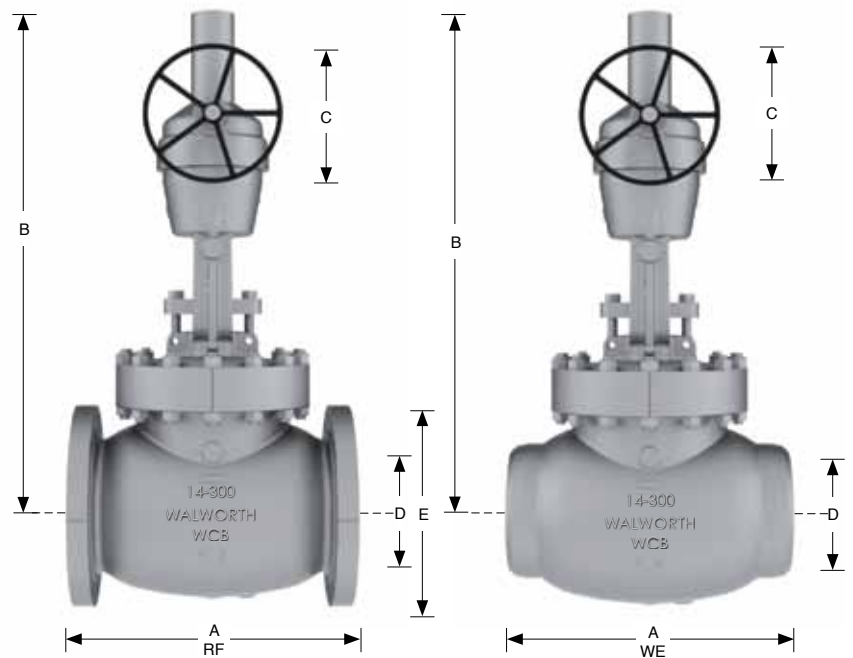

## Dimensions and Weights

D		457	508	610
Nominal Diameter	mm. / inch.	18	20	24
A	mm.	977	1016	1346
	inch.	38 1/2	40	53
B	mm.	1135	1500	1730
	inch.	44 5/8	59	68 1/8
C	mm.	600	600	600
	inch.	23 5/8	23 5/8	23 5/8
E	mm.	711	775	914
	inch.	28	30 1/2	36
Weight	kg.	1907	2119	2338
	lb.	4195	4662	5144
Weight	kg.	1678	1865	2057
	lb.	3692	4102	4526

For size and dimensions not shown, please contact our Sales Department.

# WALWORTH CAST STEEL GLOBE VALVES CLASS 600

CAST STEEL GLOBE VALVES WITH RISING HANDWHEEL AND STEM.

## DESIGN FEATURES

- Globe valves design in accordance with ASME B16.34
- Globe valves option in accordance with API-603 only for stainless steel & nickel alloys.
- Gate & globe valves for cryogenic service with gas column in accordance with BS-6364 upon request
- Flange dimensions in accordance with ASME B16.5 for valves up to 24" nominal diameter
- Handwheel, handwheel impact, chain wheel, gear operation, electric, pneumatic or hydraulic actuation as per customer requirements
- By-pass, lantern rings, grease injectors, special connections, etc.
- Low fugitive emissions control
- NACE service either MR-01-75 or MR-01-03.
- Test in accordance with API-598
- Stop check design option available

① Stem Nut, replaceable in line to avoid shut down of pipe line process.

② Revolving rising stem with precision ACME single or double thread for quick operation. Surface finish suitable to seal properly to get low fugitive emissions.

③ Stem Packing is designed for optimum control of fugitive emissions leakage to the atmosphere. The ultra low emission leakage rate is assured by the fine finish in the stem, the reduced diametrical clearances and the stem straightness control special designed packing. Live load packing arrangement available upon request.

④ Backseat either threaded or welded, designed to relieve back pressure on the stem packing when fully seated. Replacing stem packing under pressure is not recommended. Hard faced backseat available for severe service as customer requirements

⑤ Body to Bonnet Ring Type Joint designed to apply a uniform load to the gasket to assure a leak proof seal.

⑥ Conical Plug type Disc, integrally guided to assure true alignment between disc and valve body. The loose disc design allows the disc and seat ring sealing surface to seat correctly without damage.

⑦ Stellited Seat Ring is seal welded to provide a increased resistance to wear, abrasion, and erosion of the sealing surfaces.

⑧ Two pieces arrangement gland flange and stem packing bushing for self-alignment to avoid stem damage.

⑨ Impact Handwheel, the mechanism is based on transmitting the momentum generated by the mass of the handwheel through the impact/impulse generated during the snap closure action of the handwheel. This type of handwheel is used when a standard handwheel cannot create enough closing force to effect a seal. Gear operated is also available.

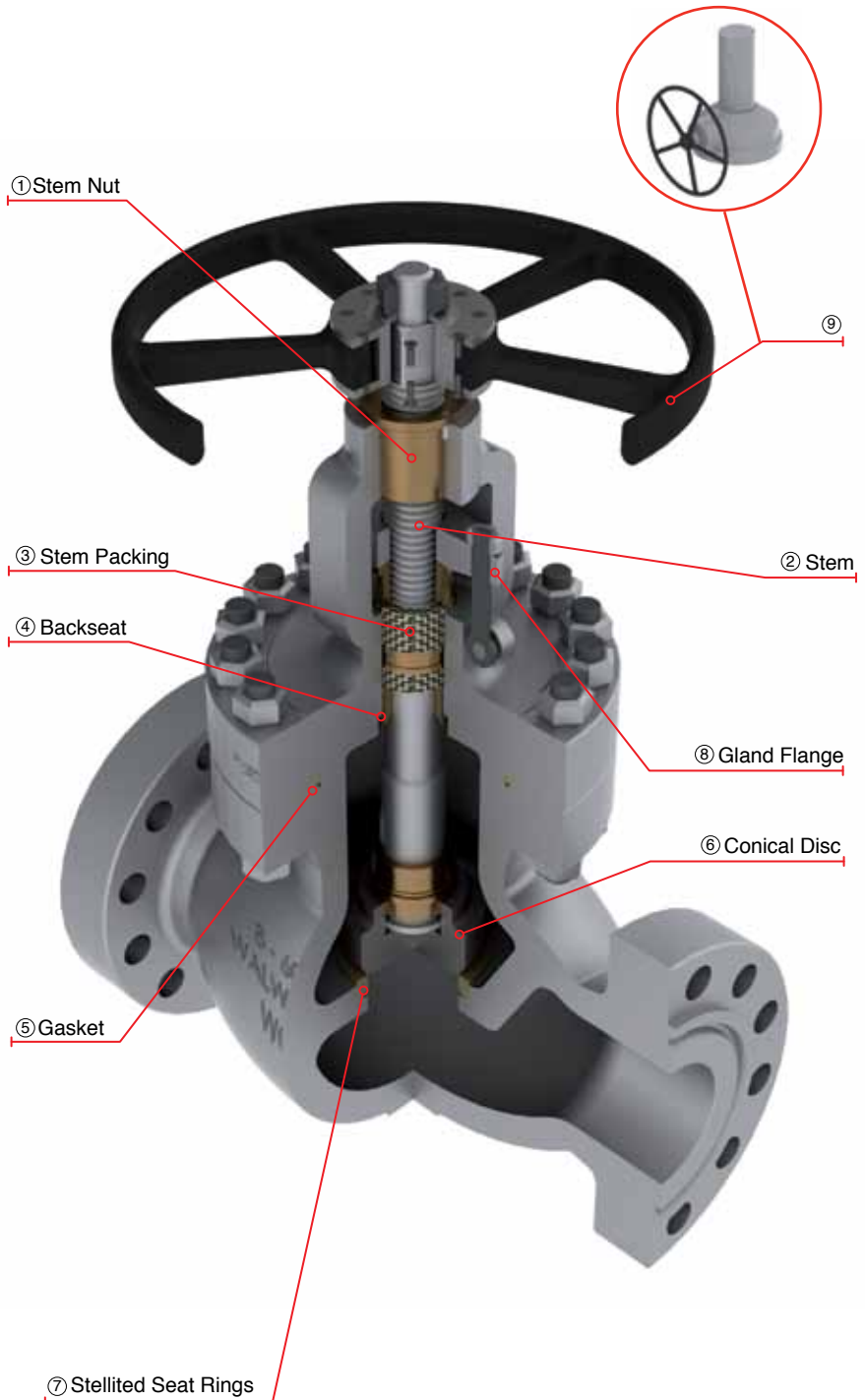

# WALWORTH CAST STEEL GLOBE VALVES, CLASS 600 (HANDWHEEL OPERATED)

- Design in accordance with ASME B 16.34
- Rising Stem and Handwheel: 2" to 6"
- Rising Stem and fixed handwheel 8" and up
- Flange dimensions as per ASME B16.5
- End to end dimensions as per ASME B16.10
- WE dimensions as per ASME B 16.25
- Bonnet with Bearings: 8" and larger
- Size 2" and 8" Handwheel operated as standard

Catalog Figure No.	ID Plant Figure No.	Type of Ends
5295RF	5295F	Flanged Raised Face
5295RTJ	5295RJ	Flanged Ring Type Joint
5295WE	5295WE	Buttweld

## Regular Bill of Materials

No.	DESCRIPTION	STANDAR MATERIAL
1	Body	ASTM A 216 GR WCB
2	Bonnet	ASTM A 216 GR WCB
3	Disc	ASTM A 276 Type 410
4	Disc Lock Nut	Alloy Steel
5	Seat Ring	ASTM A 515 GR 70 + ST6
6	Stem	ASTM A 276 Type 410
7	Stem Nut	ASTM B 148 UNS C95600
8	Eyebolt	Alloy Steel
9	Eyebolt Nut	ASTM A 307
10	Gland Flange	ASTM A 515 GR 70
11	Packing Bushing	ASTM A 108 GR 1020
12	Eyebolt Pin	Alloy Steel
13	Bonnet Stud	ASTM A 193 GR B7
14	Bonnet Stud Nut	ASTM A 194 GR 2H
15	Stem Packing	Graphite
16	Ring type Joint Gasket	ASTM A 108 GR 1010
17	Bonnet Bushing	ASTM A 276 Type 410
18	Handwheel	ASTM A 197
19	Handwheel Nut	ASTM A 307
20	Clamp	Commercial Steel
21	Impact Bushing	ASTM A 216 GR WCB
22*	Stem Nut Set Screw	Alloy Steel
23*	Identification Plate	Stainless Steel

\*Not Shown

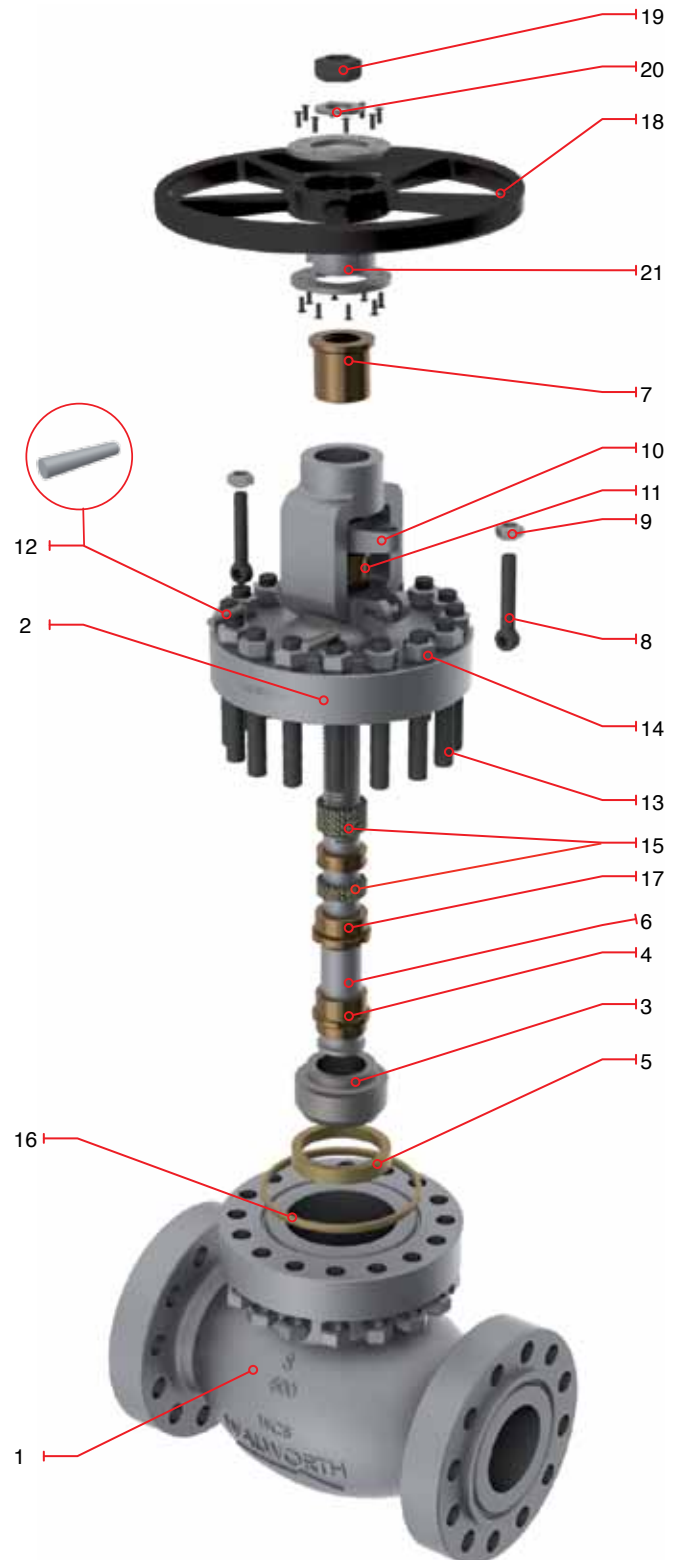

# WALWORTH CAST STEEL GLOBE VALVES, CLASS 600 (HANDWHEEL OPERATED)

- Design in accordance with ASME B 16.34
- Rising Stem and Handwheel: 2" to 6"
- Rising stem and fixed handwheel 8"
- Flange dimensions as per ASME B16.5
- End to end dimensions as per ASME B16.10
- WE dimensions as per ASME B 16.25
- Bonnet with Bearings: 8" and larger
- Size 2" and 8" Handwheel operated as standard



Catalog Figure No.	ID Plant Figure No.	Type of Ends
5295RF	5295F	Flanged Raised Face
5295RTJ	5295RJ	Flanged Ring Type Joint
5295WE	5295WE	Buttweld

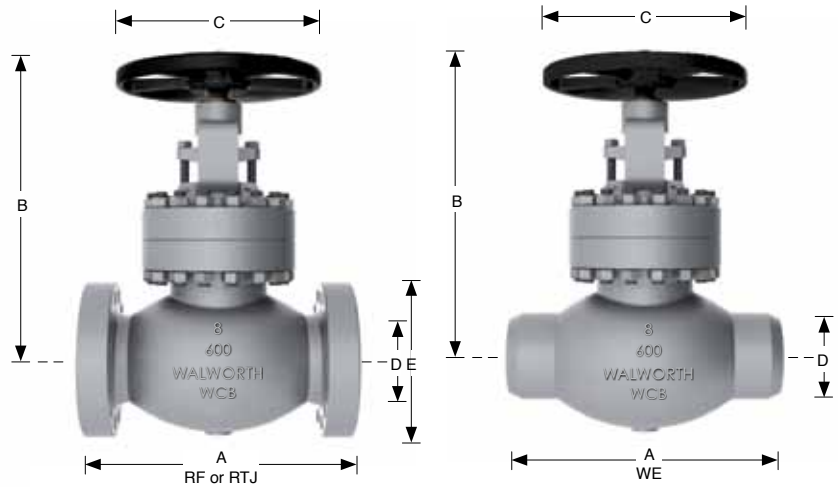

## Dimensions and Weights

D										
Nominal Diameter	mm.	51	64	76	102	152	200	254	305	
	inch	2	2 1/2	3	4	6	8	10	12	
A (RF y WE)	mm.	292	330	356	432	559	660	787	838	
	inch	11 1/2	13	14	17	22	26	31	33	
A* (RTJ)	mm.	295	333	359	435	562	663	790	841	
	inch	11 5/8	13 1/8	14 1/8	17 1/8	22 1/8	26 1/8	31 1/8	33 1/8	
B	mm.	400	501	493	582	783	925	994	1122	
	inch	15 3/4	19 3/4	19 1/2	22 7/8	30 7/8	36 3/8	39 1/8	44 1/8	
C	mm.	250	300	350	400	500	560	640	700	
	inch	10	12	14	16	20	22	25	28	
E	mm.	165	190	210	273	356	419	508	559	
	inch.	6 1/2	7 1/2	8 1/4	10 3/4	14	16 1/2	20	22	
Weight 5295RF	kg.	36	63	66	120	278	429	737	1194	
	lb.	79	139	145	264	611	944	1621	2627	
Weight 5295WE	kg.	30	52	55	102	236	365	649	1051	
	lb.	66	115	121	224	519	802	1427	2312	

For size and dimensions not shown, please contact our Sales Department.



# WALWORTH CAST STEEL GLOBE VALVES, CLASS 600 (GEAR OPERATED)

- Design in accordance with ASME B 16.34
- Rising stem
- Flange dimensions as per ASME B16.5
- End to end dimensions as per ASME B16.10
- WE dimensions as per ASME B 16.25
- Bonnet with Bearings: 8" and larger
- Size 10" and up Gear operated as standard

Catalog Figure No.	ID Plant Figure No.	Type of Ends
5295RF	5295F	Flanged Raised Face
5295RTJ	5295RJ	Flanged Ring Type Joint
5295WE	5295WE	Buttweld

## Regular Bill of Materials

No.	DESCRIPTION	STANDAR MATERIAL
1	Body	ASTM A 216 GR WCB
2	Bonnet	ASTM A 216 GR WCB
3	Disc	ASTM A 276 Type 410
4	Disc Lock Nut	Alloy Steel
5	Seat Ring	ASTM A 515 GR 70 + ST6
6	Stem	ASTM A 276 Type 410
*7	Stem Nut	ASTM B 148 UNS C95600
8	Eyebolt	Alloy Steel
9	Eyebolt Nut	ASTM A 307
10	Gland Flange	ASTM A 515 GR 70
11	Packing Bushing	ASTM A 108 GR 1020
12	Eyebolt Pin	Alloy Steel
13	Bonnet Stud	ASTM A 193 GR B7
14	Bonnet Stud Nut	ASTM A 194 GR 2H
15	Stem Packing	Graphite
16	Rising type Joint Gasket	ASTM A 108 GR 1010
17	Bonnet Bushing	ASTM A 276 Type 410
18	Gear Operator	as customer requirements
*19	Operator Bolts	Alloy Steel
*20	Identification Plate	Stainless Steel

\*Not Shown

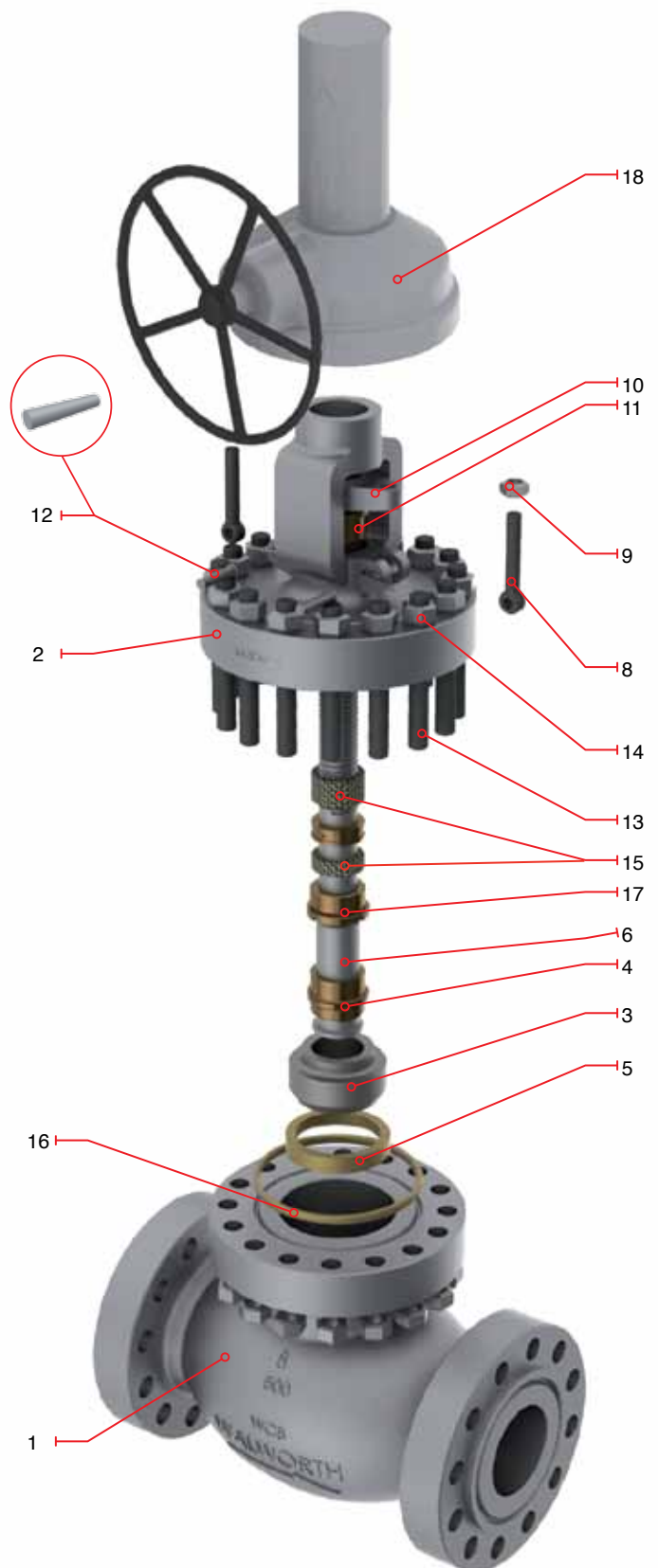

# WALWORTH CAST STEEL GLOBE VALVES, CLASS 600 (GEAR OPERATED)



- Design in accordance with ASME B 16.34
- Rising Stem
- Flange dimensions as per ASME B16.5
- End to end dimensions as per ASME B16.10
- WE dimensions as per ASME B 16.25
- Bonnet with Bearings: 8" and larger
- Size 10" and up Gear operated as standard

Catalog Figure No.	ID Plant Figure No.	Type of Ends
5295RF	5295F	Flanged Raised Face
5295RTJ	5295RJ	Flanged Ring Type Joint
5295WE	5295WE	Buttweld

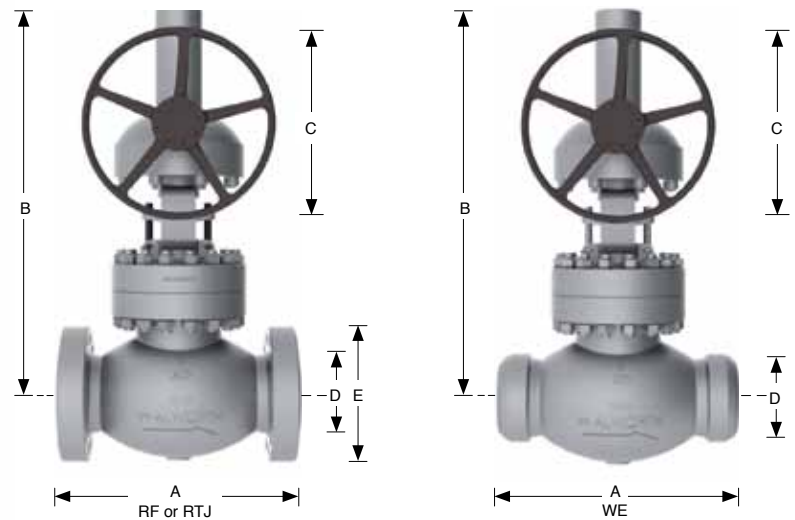

## Dimensions and Weights

D		356		406		457		508		610	
Nominal Diameter		mm.		inch		mm.		inch		mm.	
A	mm.	889	991	POA	POA	POA	POA	POA	POA	POA	POA
(RF y WE)	inch	35	39	POA	POA	POA	POA	POA	POA	POA	POA
A*	mm.	892	994	POA	POA	POA	POA	POA	POA	POA	POA
(RTJ)	inch	35 1/8	39 1/8	POA	POA	POA	POA	POA	POA	POA	POA
B	mm.	1196	1327	POA	POA	POA	POA	POA	POA	POA	POA
	inch	47 1/8	52 1/4	POA	POA	POA	POA	POA	POA	POA	POA
C	mm.	600	600	POA	POA	POA	POA	POA	POA	POA	POA
	inch	23 5/8	23 5/8	POA	POA	POA	POA	POA	POA	POA	POA
E	mm.	603	686	745	815	940					
	inch.	23 3/4	27	29 1/4	32	37					
Weight	kg.	1421	1899	POA	POA	POA	POA	POA	POA	POA	POA
5295RF	lb.	3126	4178	POA	POA	POA	POA	POA	POA	POA	POA
Weight	kg.	1322	1766	-	-	-	-	-	-	-	-
5295WE	lb.	2907	3885	-	-	-	-	-	-	-	-

For size and dimensions not shown, please contact our Sales Department.

# WALWORTH CAST STEEL GLOBE VALVES CLASS 900

CAST STEEL GLOBE VALVES WITH RISING HANDWHEEL AND STEM.

## DESIGN FEATURES

- Globe valves design in accordance with ASME B16.34
- Globe valves option in accordance with API-603 only for stainless steel & nickel alloys.
- Gate & globe valves for cryogenic service with gas column in accordance with BS-6364 upon request
- Flange dimensions in accordance with ASME B16.5 for valves up to 24" nominal diameter
- Handwheel, handwheel impact, chain wheel, gear operation, electric, pneumatic or hydraulic actuation as per customer requirements
- By-pass, lantern rings, grease injectors, special connections, etc.
- Low fugitive emissions control
- NACE service either MR-01-75 or MR-01-03.
- Test in accordance with API-598
- Stop check design option available

- ① Stem Nut, replaceable in line to avoid shut down of pipe line process.
- ② Revolving rising stem with precision ACME single or double thread for quick operation. Surface finish suitable to seal properly to get low fugitive emissions.
- ③ Stem Packing is designed for optimum control of fugitive emissions leakage to the atmosphere. The ultra low emission leakage rate is assured by the fine finish in the stem, the reduced diametrical clearances and the stem straightness control special designed packing. Live load packing arrangement available upon request.
- ④ Backseat either threaded or welded, designed to relieve back pressure on the stem packing when fully seated. Replacing stem packing under pressure is not recommended. Hard faced backseat available for severe service as customer requirements
- ⑤ Body to Bonnet Ring Type Joint designed to apply a uniform load to the gasket to assure a leak proof seal.
- ⑥ Conical Plug type Disc, integrally guided to assure true alignment between disc and valve body. The loose disc design allows the disc and seat ring sealing surface to seat correctly without damage.
- ⑦ Stellite Seat Rings is seal welded to provide a increased resistance to wear, abrasion, and erosion of the sealing surfaces.
- ⑧ Two pieces arrangement gland flange and stem packing bushing for self-alignment to avoid stem damage.
- ⑨ Impact Handwheel, the mechanism is based on transmitting the momentum generated by the mass of the handwheel through the impact/impulse generated during the snap closure action of the handwheel. This type of handwheel is used when a standard handwheel cannot create enough closing force to effect a seal. Gear operated is also available.

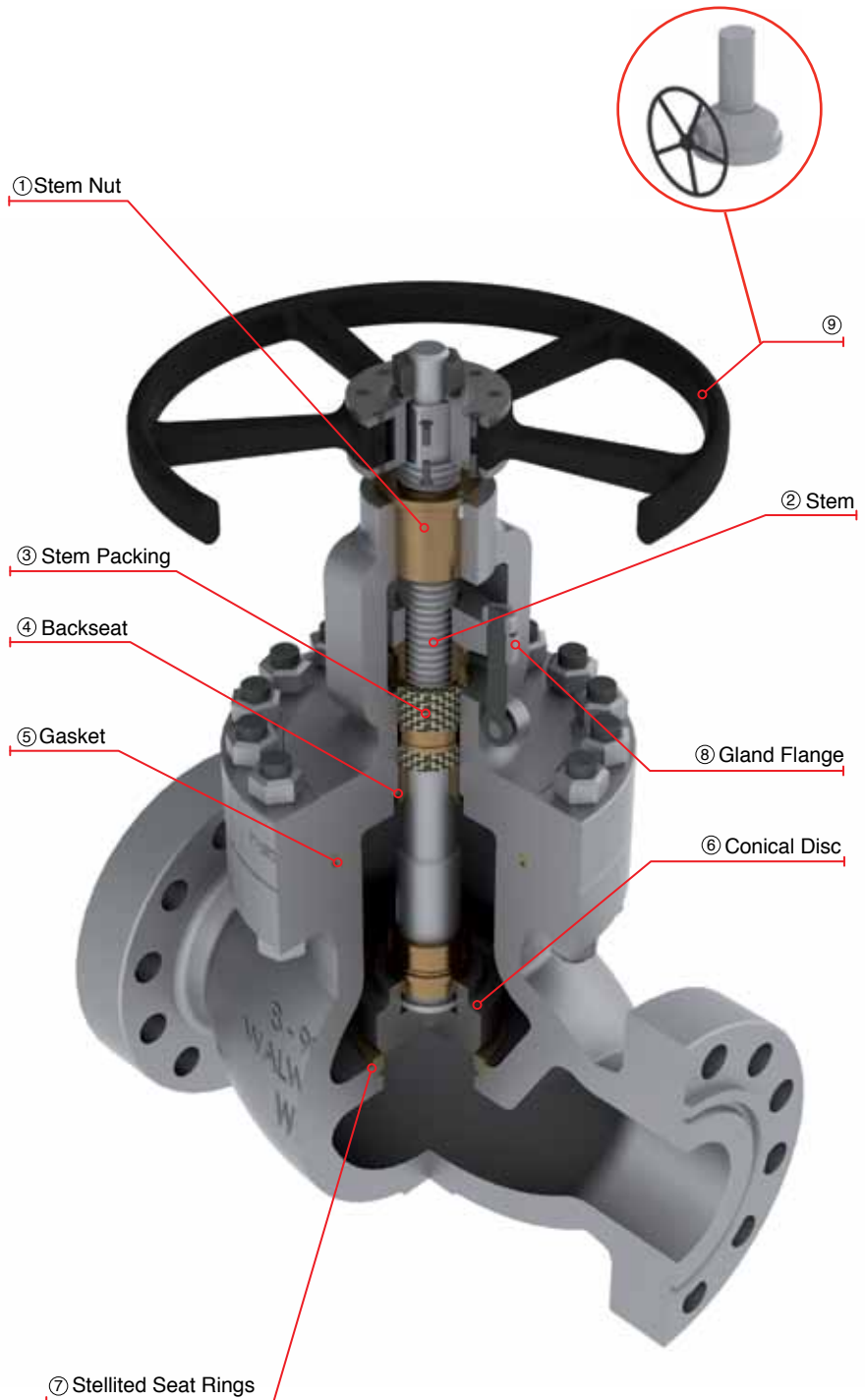

# WALWORTH CAST STEEL GLOBE VALVES, CLASS 900 (HANDWHEEL OPERATED)

- Design in accordance with ASME B 16.34
- Rising Stem and Handwheel: 2" to 3"
- Rising Stem and Fixed Handwheel: 4" and up
- Flange dimensions as per ASME B16.5
- End to end dimensions as per ASME B16.10
- WE dimensions as per ASME B 16.25
- Bonnet with bearings 4" and larger
- Size 2" to 6" Handwheel operated as standard

Catalog Figure No.	ID Plant Figure No.	Type of Ends
5301RF	5301F	Flanged Raised Face
5301RTJ	5301RJ	Flanged Ring Type Joint
5301WE	5301WE	Buttweld

## Regular Bill of Materials

No.	DESCRIPTION	STANDAR MATERIAL
1	Body	ASTM A 216 GR WCB
2	Bonnet	ASTM A 216 GR WCB
3	Disc	ASTM A 276 Type 410
4	Disc Lock Nut	Alloy Steel
5	Seat Ring	ASTM A 515 GR 70 + ST6
6	Stem	ASTM A 276 Type 410
7	Stem Nut	ASTM B 148 UNS C95600
8	Eyebolt	Alloy Steel
9	Eyebolt Nut	ASTM A 307
10	Gland Flange	ASTM A 515 GR 70
11	Packing Bushing	ASTM A 108 GR 1020
12	Eyebolt Pin	Alloy Steel
13	Bonnet Stud	ASTM A 193 GR B7
14	Bonnet Stud Nut	ASTM A 194 GR 2H
15	Stem Packing	Graphite
16	Ring type Joint Gasket	ASTM A 108 GR 1010
17	Bonnet Bushing	ASTM A 276 Type 410
18	Handwheel	ASTM A 197
19	Handwheel Nut	ASTM A 307
20	Clamp	Commercial Steel
21	Impact Bushing	ASTM A 216 GR WCB
22*	Stem Nut Set Screw	Alloy Steel
23*	Identification Plate	Stainless Steel

\*Not Shown

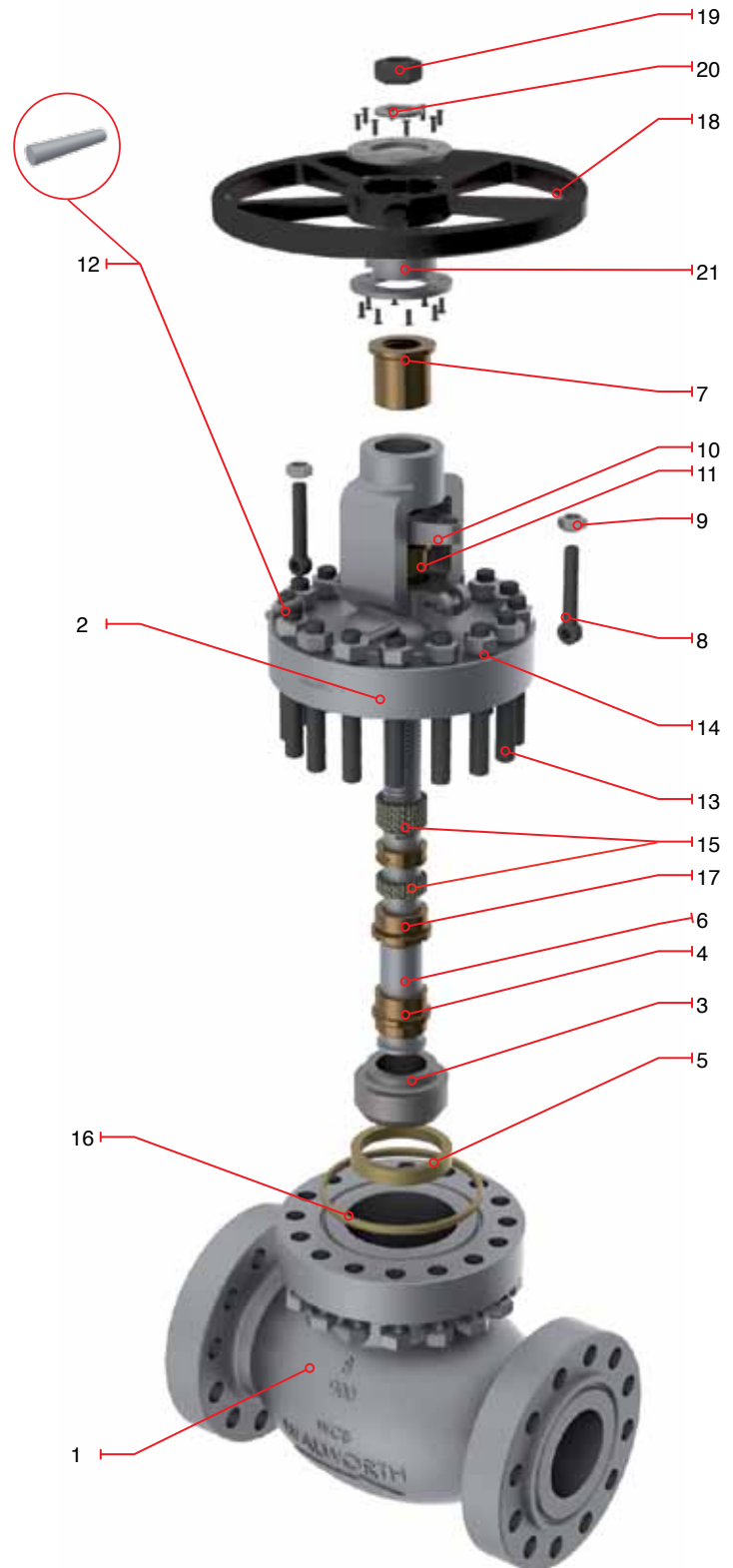

# WALWORTH CAST STEEL GLOBE VALVES, CLASS 900 (HANDWHEEL OPERATED)

- Design in accordance with ASME B 16.34
- Rising Stem and Handwheel: 2" to 3"
- Rising Stem and Fixed Handwheel: 4" and up
- Flange dimensions as per ASME B16.5
- End to end dimensions as per ASME B16.10
- WE dimensions as per ASME B 16.25
- Bonnet with bearings 4" and larger
- Size 2" to 6" Handwheel operated as standard

Catalog Figure No.	ID Plant Figure No.	Type of Ends
5301RF	5301F	Flanged Raised Face
5301RTJ	5301RJ	Flanged Ring Type Joint
5301WE	5301WE	Buttweld

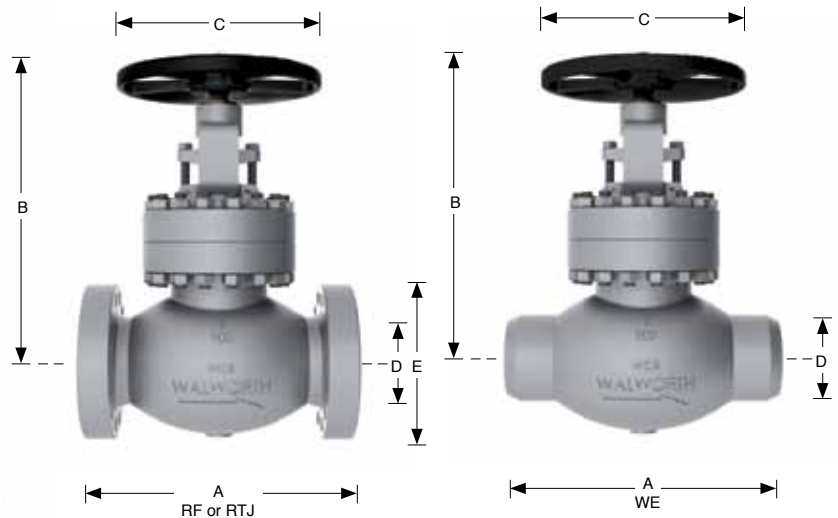

## Dimensions and Weights

D		76	102	152	203
Nominal Diameter	mm. inch.	3	4	6	8
A	mm.	381	457	610	737
(RF y WE)	inch	15	18	24	29
A*	mm.	384	460	613	740
(RTJ)	inch	15 1/8	18 1/8	24 1/8	29 1/8
B	mm.	573	738	854	907
	inch	22 1/2	29	33 5/8	35 3/4
C	mm.	400	450	560	640
	inch	16	18	22	25
E	mm.	241	292	381	470
	inch.	9 1/2	11 1/2	15	18 1/2
Weight	kg.	113	206	328	593
5301RF	lb.	249	453	722	1305
Weight	kg.	94	175	279	504
5301WE	lb.	206	385	613	1109

For size and dimensions not shown, please contact our Sales Department.

# WALWORTH CAST STEEL GLOBE VALVES, CLASS 900 (GEAR OPERATED)

- Design in accordance with ASME B16.34
- Rising stem
- Flange dimensions as per ASME B16.5
- End to end dimensions as per ASME B16.10
- WE dimensions as per ASME B 16.25
- Size 8" and up Gear operated as standard

Catalog Figure No.	ID Plant Figure No.	Type of Ends
5301RF	5301F	Flanged Raised Face
5301RTJ	5301RJ	Flanged Ring Type Joint
5301WE	5301WE	Buttweld

## Regular Bill of Materials

No.	DESCRIPTION	STANDAR MATERIAL
1	Body	ASTM A 216 GR WCB
2	Bonnet	ASTM A 216 GR WCB
3	Disc	ASTM A 276 Type 410
4	Disc Lock Nut	Alloy Steel
5	Seat Ring	ASTM A 515 GR 70 + ST6
6	Stem	ASTM A 276 Type 410
*7	Stem Nut	ASTM B 148 UNS C95600
8	Eyebolt	Alloy Steel
9	Eyebolt Nut	ASTM A 307
10	Gland Flange	ASTM A 515 GR 70
11	Packing Bushing	ASTM A 108 GR 1020
12	Eyebolt Pin	Alloy Steel
13	Bonnet Stud	ASTM A 193 GR B7
14	Bonnet Stud Nut	ASTM A 194 GR 2H
15	Stem Packing	Graphite
16	Ring type Joint Gasket	ASTM A 108 GR 1010
17	Bonnet Bushing	ASTM A 276 Type 410
18	Gear Operator	as customer requirements
*19	Operator Bolts	Alloy Steel
*20	Identification Plate	Stainless Steel

\*Not Shown

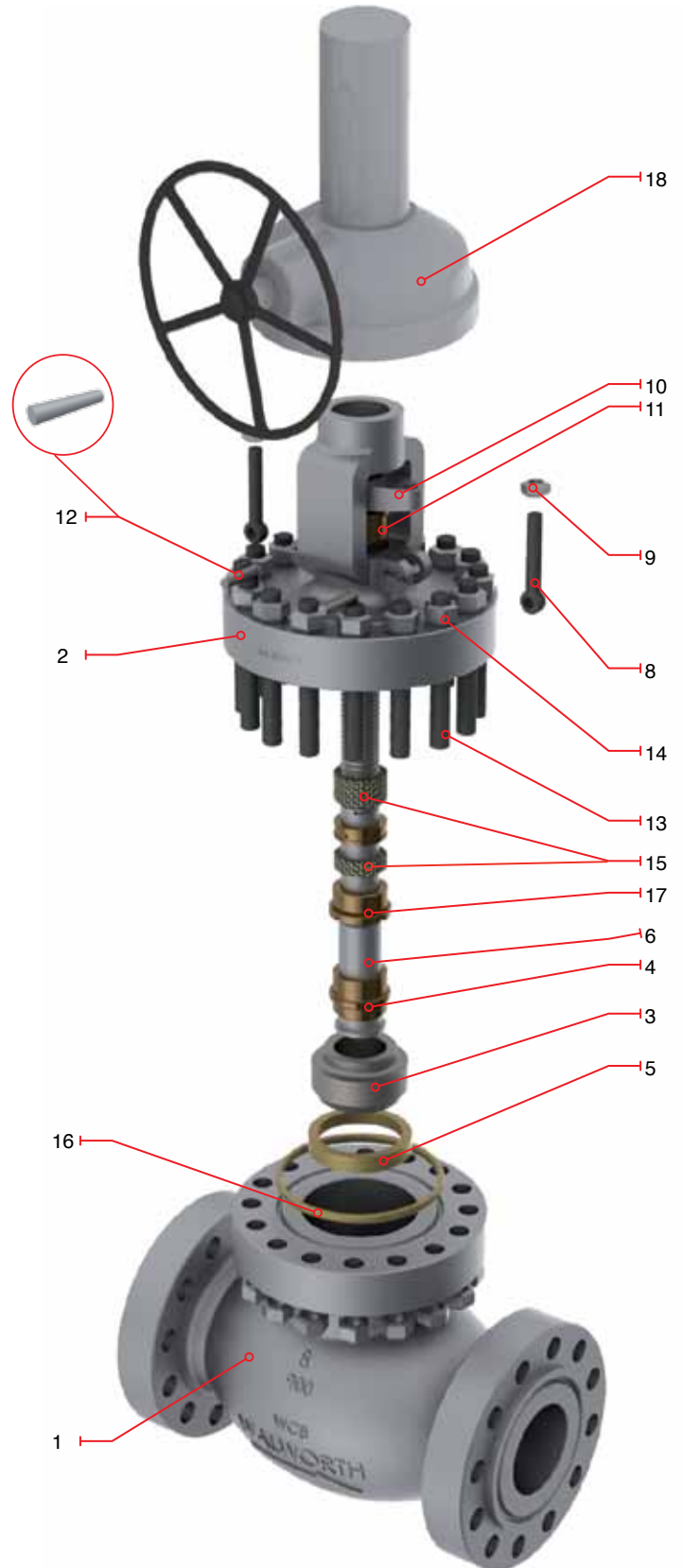

# WALWORTH CAST STEEL GLOBE VALVES, CLASS 900 (GEAR OPERATED)



- Design in accordance with ASME B16.34
- Rising stem
- Size 8" and up Gear operated as standard
- Flange dimensions as per ASME B16.5
- End to end dimensions as per ASME B16.10
- WE dimensions as per ASME B 16.25

Catalog Figure No.	ID Plant Figure No.	Type of Ends
5301RF	5301F	Flanged Raised Face
5301RTJ	5301RJ	Flanged Ring Type Joint
5301WE	5301WE	Buttweld

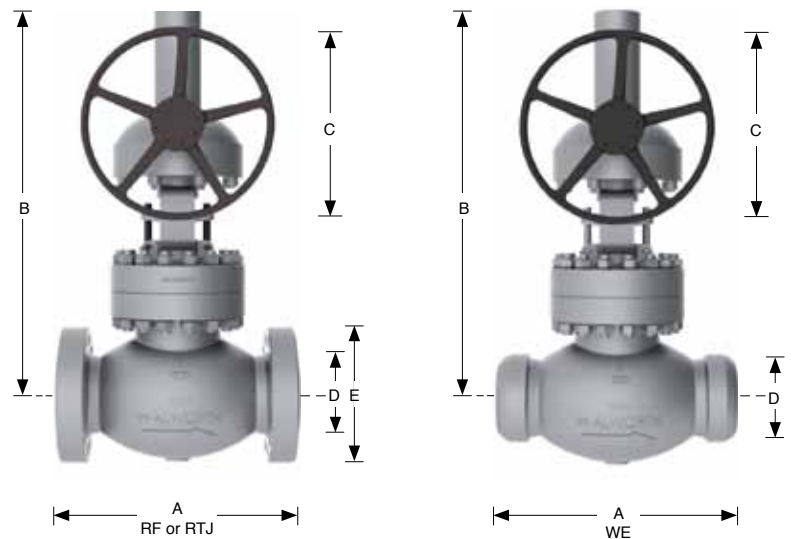

## Dimensions and Weights

D		254	305	356	406	457	508	610
Nominal Diameter	mm. inch	10	12	14	16	18	20	24
A	mm.	838	965	1029	POA	POA	POA	POA
(RF y WE)	inch	33	38	40 1/2	POA	POA	POA	POA
A*	mm.	841	968	1038	POA	POA	POA	POA
(RTJ)	inch	33 1/8	38 1/8	40 7/8	POA	POA	POA	POA
B	mm.	980	1286	2083	POA	POA	POA	POA
	inch	38 5/8	50 5/8	82	POA	POA	POA	POA
C	mm.	530	600	956	POA	POA	POA	POA
	inch	20 7/8	23 5/8	38	POA	POA	POA	POA
E	mm.	545	610	640	705	785	855	1040
	inch.	21 1/2	24	25 1/4	27 3/4	31	33 3/4	41
Weight	kg.	1850	2998	2900	POA	POA	POA	POA
5301RF	lb.	4070	6596	6380	POA	POA	POA	POA
Weight	kg.	1721	2788	2697	POA	POA	POA	POA
5301WE	lb.	3785	6134	5933	POA	POA	POA	POA

For size and dimensions not shown, please contact our Sales Department.

# WALWORTH CAST STEEL GLOBE VALVES CLASS 1500

CAST STEEL GLOBE VALVES WITH RISING HANDWHEEL AND STEM.

## DESIGN FEATURES

- Globe valves design in accordance with ASME B16.34
- Globe valves option in accordance with API-603 only for stainless steel & nickel alloys.
- Gate & globe valves for cryogenic service with gas column in accordance with BS-6364 upon request
- Flange dimensions in accordance with ASME B16.5 for valves up to 24" nominal diameter
- Handwheel, handwheel impact, chain wheel, gear operation, electric, pneumatic or hydraulic actuation as per customer requirements
- By-pass, lantern rings, grease injectors, special connections, etc.
- Low fugitive emissions control
- NACE service either MR-01-75 or MR-01-03.
- Test in accordance with API-598
- Stop check design option available

- ① Stem Nut, replaceable in line to avoid shut down of pipe line process.
- ② Revolving rising stem with precision ACME single or double thread for quick operation. Surface finish suitable to seal properly to get low fugitive emissions.
- ③ Stem Packing is designed for optimum control of fugitive emissions leakage to the atmosphere. The ultra low emission leakage rate is assured by the fine finish in the stem, the reduced diametrical clearances and the stem straightness control special designed packing. Live load packing arrangement available upon request.
- ④ Backseat either threaded or welded, designed to relieve back pressure on the stem packing when fully seated. Replacing stem packing under pressure is not recommended. Hard faced backseat available for severe service as customer requirements
- ⑤ Body to Bonnet Joint designed to apply a uniform load to the gasket to assure a leak proof seal.
- ⑥ Conical Plug type Disc, integrally guided to assure true alignment between disc and valve body. The loose disc design allows the disc and seat ring sealing surface to seat correctly without damage.
- ⑦ Stellite Seat Ring is seal welded to provide an increased resistance to wear, abrasion, and erosion of the sealing surfaces.
- ⑧ Two pieces arrangement gland flange and stem packing bushing for self-alignment to avoid stem damage.
- ⑨ Impact Handwheel, the mechanism is based on transmitting the momentum generated by the mass of the handwheel through the impact/impulse generated during the snap closure action of the handwheel. This type of handwheel is used when a standard handwheel cannot create enough closing force to effect a seal. Gear operated is also available.

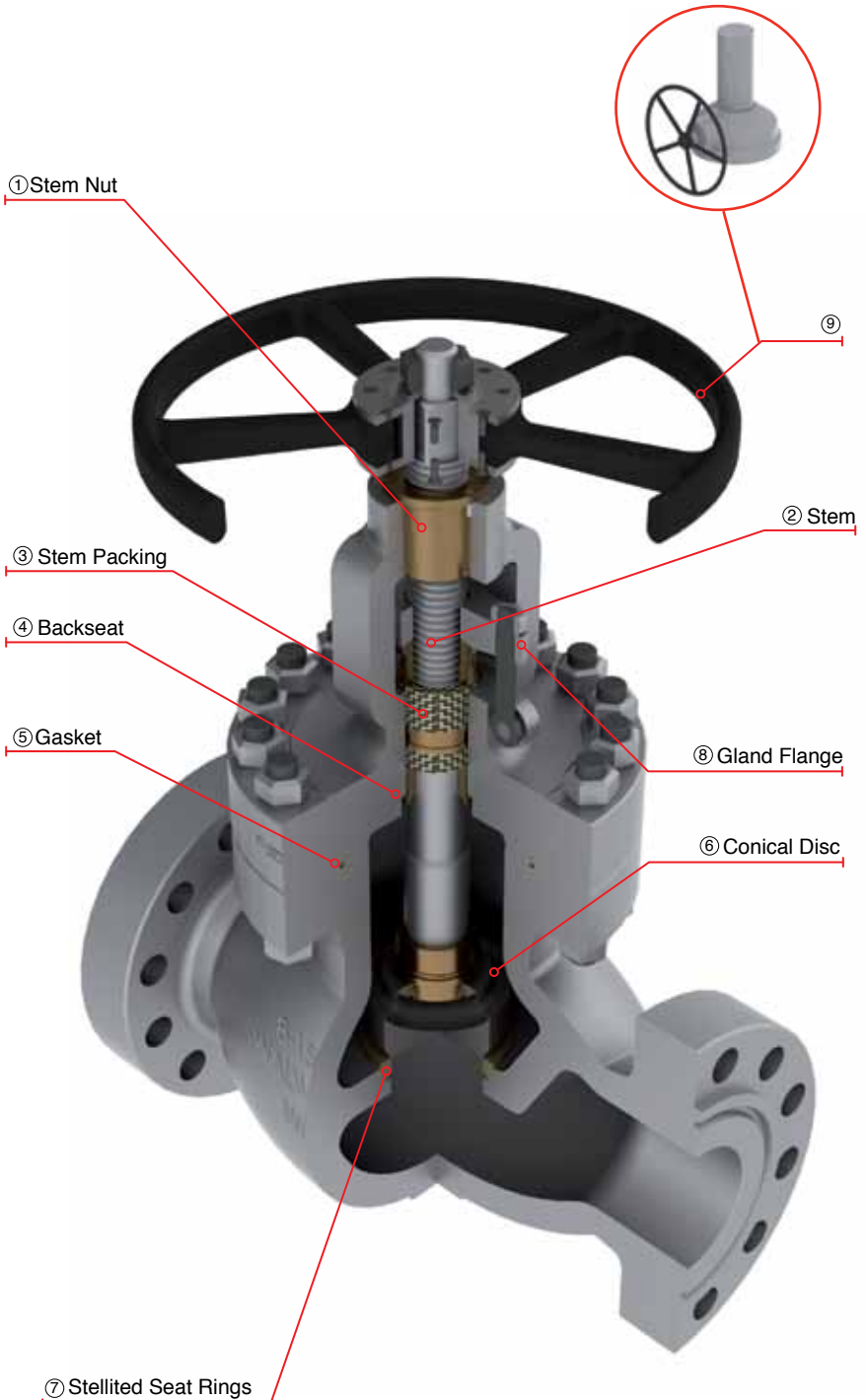



# WALWORTH CAST STEEL GLOBE VALVES, CLASS 1500 (HANDWHEEL OPERATED)

- Design in accordance with ASME B16.34
- Rising Stem and Handwheel: 2" and 2 1/2"
- Rising Stem and Fixed Handwheel: 3" and up
- Flange dimensions as per ASME B16.5
- End to end dimensions as per ASME B16.10
- WE dimensions as per ASME B 16.25
- Yoke with Bearings: 3" and larger
- Size 2" to 6" Handwheel operated as standard

Catalog Figure No.	ID Plant Figure No.	Type of Ends
5308RF	5308F	Flanged Raised Face
5308RTJ	5308RJ	Flanged Ring Type Joint
5308WE	5308WE	Buttweld

## Regular Bill of Materials

No.	DESCRIPTION	STANDAR MATERIAL
1	Body	ASTM A 216 GR WCB
2	Bonnet	ASTM A 216 GR WCB
3	Disc	ASTM A 276 Type 410
4	Disc Lock Nut	Alloy Steel
5	Seat Ring	ASTM A 515 GR 70 + ST6
6	Stem	ASTM A 276 Type 410
7	Stem Nut	ASTM B 148 UNS C95600
8	Eyebolt	Alloy Steel
9	Eyebolt Nut	ASTM A 307
10	Gland Flange	ASTM A 515 GR 70
11	Packing Bushing	ASTM A 108 GR 1020
12	Eyebolt Pin	Alloy Steel
13	Bonnet Stud	ASTM A 193 GR B7
14	Bonnet Stud Nut	ASTM A 194 GR 2H
15	Stem Packing	Graphite
16	Ring type Joint Gasket	ASTM A 108 GR 1010
17	Bonnet Bushing	ASTM A 276 Type 410
18	Handwheel	ASTM A 197
19	Handwheel Nut	ASTM A 307
20	Clamp	Commercial Steel
21	Impact Bushing	ASTM A 216 GR WCB
22*	Stem Nut Set Screw	Alloy Steel
23*	Identification Plate	Stainless Steel

\*Not Shown

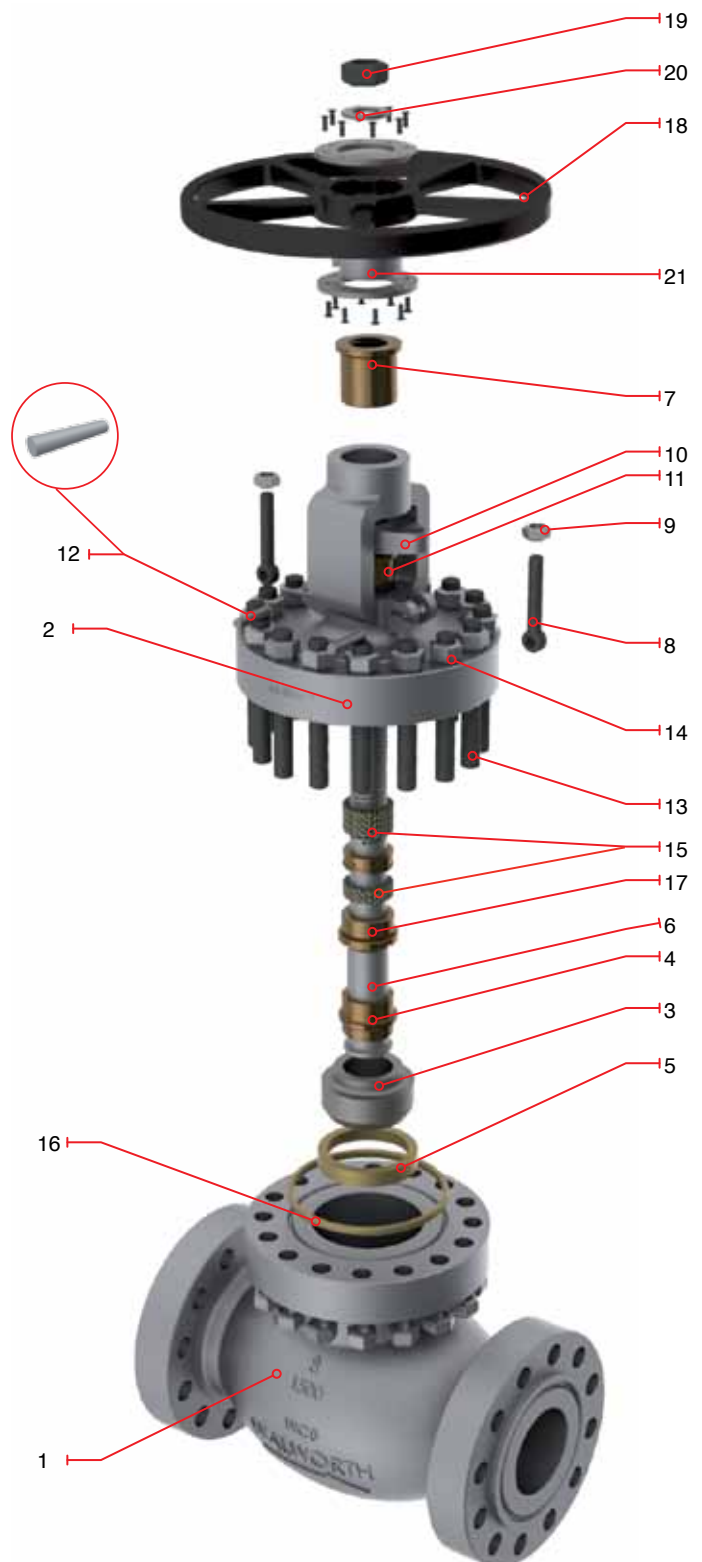

# WALWORTH CAST STEEL GLOBE VALVES, CLASS 1500 (HANDWHEEL OPERATED)

- Design in accordance with ASME B16.34
- Rising Stem and Handwheel: 2" and 2 1/2"
- Rising Stem and Fixed Handwheel: 3" and up
- Flange dimensions as per ASME B16.5
- End to end dimensions as per ASME B16.10
- WE dimensions as per ASME B 16.25
- Yoke with Bearings: 3" and larger
- Size 2" to 6" Handwheel operated as standard



Catalog Figure No.	ID Plant Figure No.	Type of Ends
5308RF	5308F	Flanged Raised Face
5308RTJ	5308RJ	Flanged Ring Type Joint
5308WE	5308WE	Buttweld

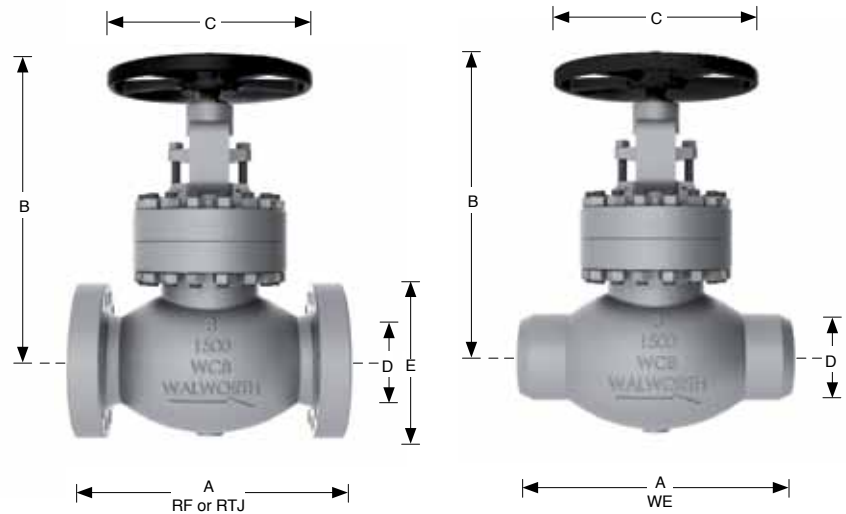

## Dimensions and Weights

D		Nominal Diameter		51	64	76	102	152	203
		mm.	inch	2	2 1/2	3	4	6	8
A	mm.	368	419	470	546	705	832		
	inch	14 1/2	16 1/2	18 1/2	21 1/2	27 3/4	32 3/4		
A*	mm.	371	422	473	549	711	842		
	inch	14 5/8	16 5/8	18 5/8	21 5/8	28	33 1/8		
B	mm.	477	537	622	733	933	1029		
	inch	18 3/4	21 1/4	24 1/2	28 7/8	36 3/4	40 1/2		
C	mm.	350	350	450	450	640	640		
	inch	14	14	18	18	25	25		
E	mm.	216	244	267	311	394	483		
	inch.	8 1/2	9 5/8	10 1/2	12 1/4	15 1/2	19		
Weight	kg.	82	121	161	252	574	949		
	lb.	180	266	354	554	1262	2088		
Weight	kg.	68	100	134	214	487	807		
	lb.	150	221	294	471	1072	1775		

For size and dimensions not shown, please contact our Sales Department.

# WALWORTH CAST STEEL GLOBE VALVES, CLASS 1500 (GEAR OPERATED)

- Design in accordance with ASME B16.34
- Rising stem
- Flange dimensions as per ASME B16.5
- End to end dimensions as per ASME B16.10
- WE dimensions as per ASME B 16.25
- Yoke with Bearings: 3" and larger
- Size 8" and up Gear operated as standard

Catalog Figure No.	ID Plant Figure No.	Type of Ends
5308RF	5308F	Flanged Raised Face
5308RTJ	5308RJ	Flanged Ring Type Joint
5308WE	5308WE	Buttweld

## Regular Bill of Materials

No.	DESCRIPTION	STANDAR MATERIAL
1	Body	ASTM A 216 GR WCB
2	Bonnet	ASTM A 216 GR WCB
3	Disc	ASTM A 276 Type 410
4	Disc Lock Nut	Alloy Steel
5	Seat Ring	ASTM A 515 GR 70 + ST6
6	Stem	ASTM A 276 Type 410
*7	Stem Nut	ASTM B 148 UNS C95600
8	Eyebolt	Alloy Steel
9	Eyebolt Nut	ASTM A 307
10	Gland Flange	ASTM A 515 GR 70
11	Packing Bushing	ASTM A 108 GR 1020
12	Eyebolt Pin	Alloy Steel
13	Bonnet Stud	ASTM A 193 GR B7
14	Bonnet Stud Nut	ASTM A 194 GR 2H
15	Stem Packing	Graphite
16	Ring type Joint Gasket	ASTM A 108 GR 1010
17	Bonnet Bushing	ASTM A 276 Type 410
18	Gear Operator	as customer requirements
*19	Operator Bolts	Alloy Steel
*20	Identification Plate	Stainless Steel

\*Not Shown

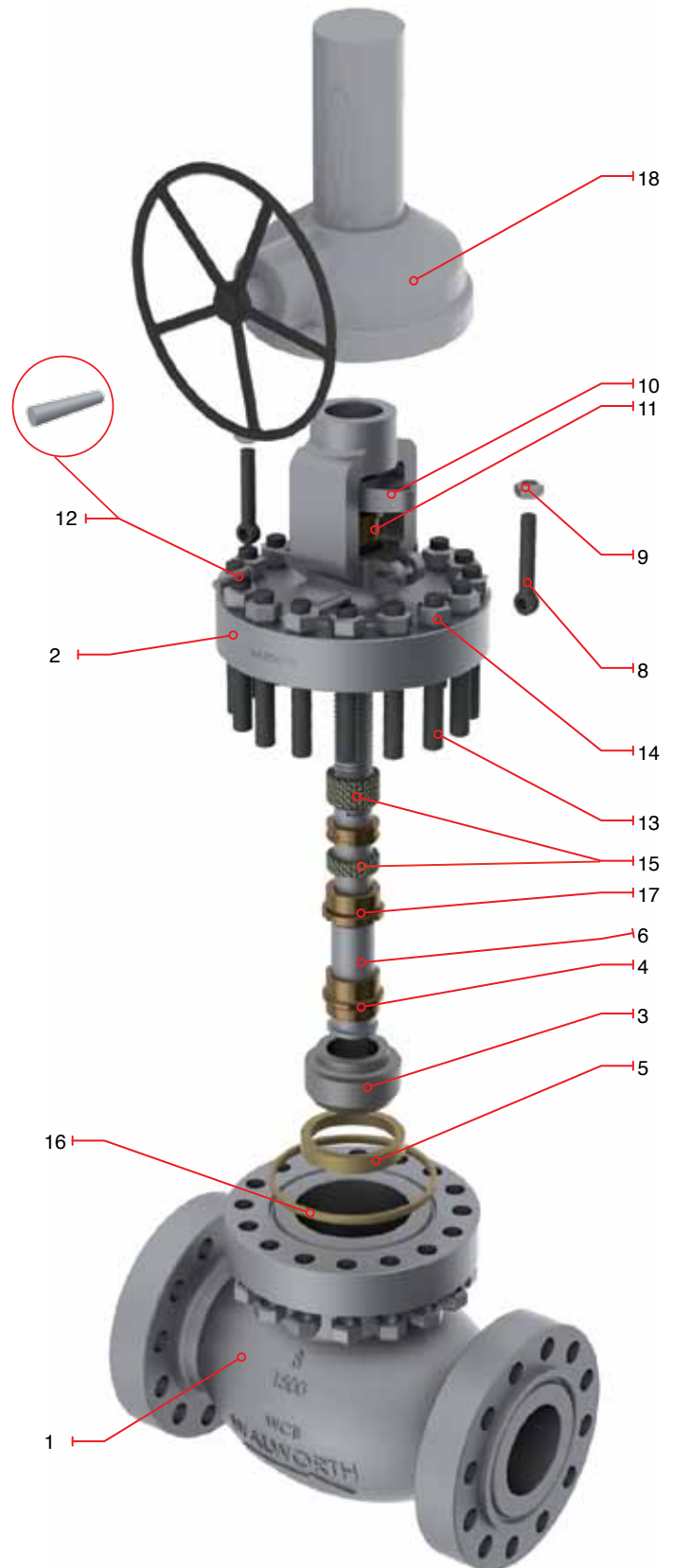

# WALWORTH CAST STEEL GLOBE VALVES, CLASS 1500

- Design in accordance with ASME B16.34
- Rising stem
- Flange dimensions as per ASME B16.5
- End to end dimensions as per ASME B16.10
- WE dimensions as per ASME B 16.25 Yoke with Bearings:
- Yoke with Bearings: 3" and larger
- Size 8" and up to 24" Gear operated as standard



Catalog Figure No.	ID Plant Figure No.	Type of Ends
5308RF	5308F	Flanged Raised Face
5308RTJ	5308RJ	Flanged Ring Type Joint
5308WE	5308WE	Buttweld

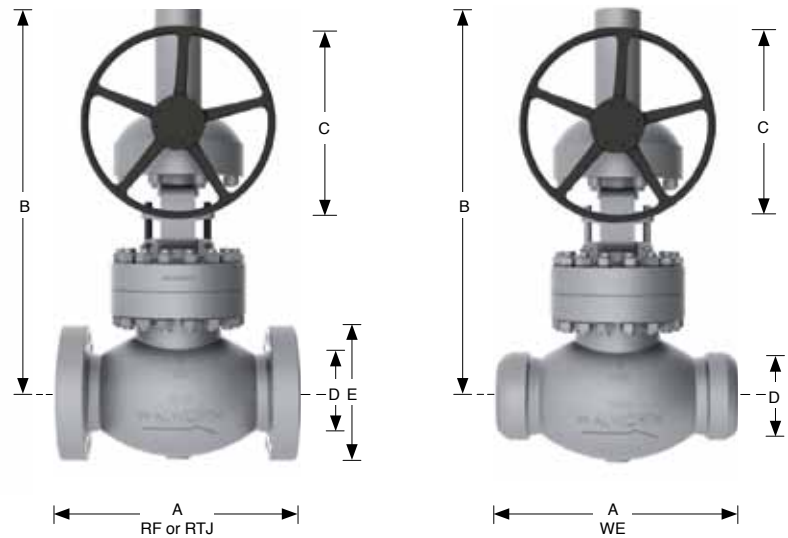

## Dimensions and Weights

D		254	305	356	406	457	508	610
Nominal Diameter	mm. inch	10	12	14	16	18	20	24
A (RF y WE)	mm.	991	1130	1257	POA	POA	POA	POA
	inch	39	44 1/2	49 1/2	POA	POA	POA	POA
A* (RTJ)	mm.	1001	1146	1276	POA	POA	POA	POA
	inch	39 3/8	45 1/8	50 1/4	POA	POA	POA	POA
B	mm.	1618	1675	1800	POA	POA	POA	POA
	inch	63 3/4	66	70 3/4	POA	POA	POA	POA
C	mm.	600	600	600	POA	POA	POA	POA
	inch	23 5/8	23 5/8	23 5/8	POA	POA	POA	POA
E	mm.	585	673	750	825	915	985	1170
	inch.	23	26 1/2	29 1/2	32 1/2	36	38 3/4	46
Weight 5308RF	kg.	2238	3308	4678	POA	POA	POA	POA
	lb.	4924	7278	10292	POA	POA	POA	POA
Weight 5308WE	kg.	2081	3076	4351	POA	POA	POA	POA
	lb.	4579	6768	9571	POA	POA	POA	POA

For size and dimensions not shown, please contact our Sales Department.

# WALWORTH CAST STEEL SWING CHECK VALVES CLASS 150

## CAST STEEL SWING CHECK VALVES

### DESIGN FEATURES

- Swing check valves design in accordance with API-6D & ASME B16.34.
- Swing check valves option in accordance with API-603 only for stainless steel & Nickel alloys.
- Swing check valves for cryogenic service in accordance with BS-6364.
- Flange dimensions in accordance with ASME B16.5 for valves up to 24" nominal diameter.
- Damper & Counter weight options.
- Drain connections as per Customer request.
- Low fugitive emissions control.
- NACE service either MR-01-75 or MR-01-03.
- Test in accordance with API-598.

- ① Body to Cover Joint designed to apply a uniform load to the gasket to assure a leak proof seal.
- ② Disc to Hanger connection allows the disc a controlled movement independent of the hanger to assure proper disc alignment with the seat at closure.
- ③ The connection is secured by a welded disc nut to prevent disassembly due to vibration and closure impact.
- ④ Stellite Seat Ring provides increased resistance to wear abrasion and erosion of the sealing surface.
- ⑤ For 8" and up, WALWORTH check valves have cover lug for easy installation
- ⑥ Body with heavy wall thickness as per ASME B16.34 for maximum service life. Provided with bosses for optional drains.

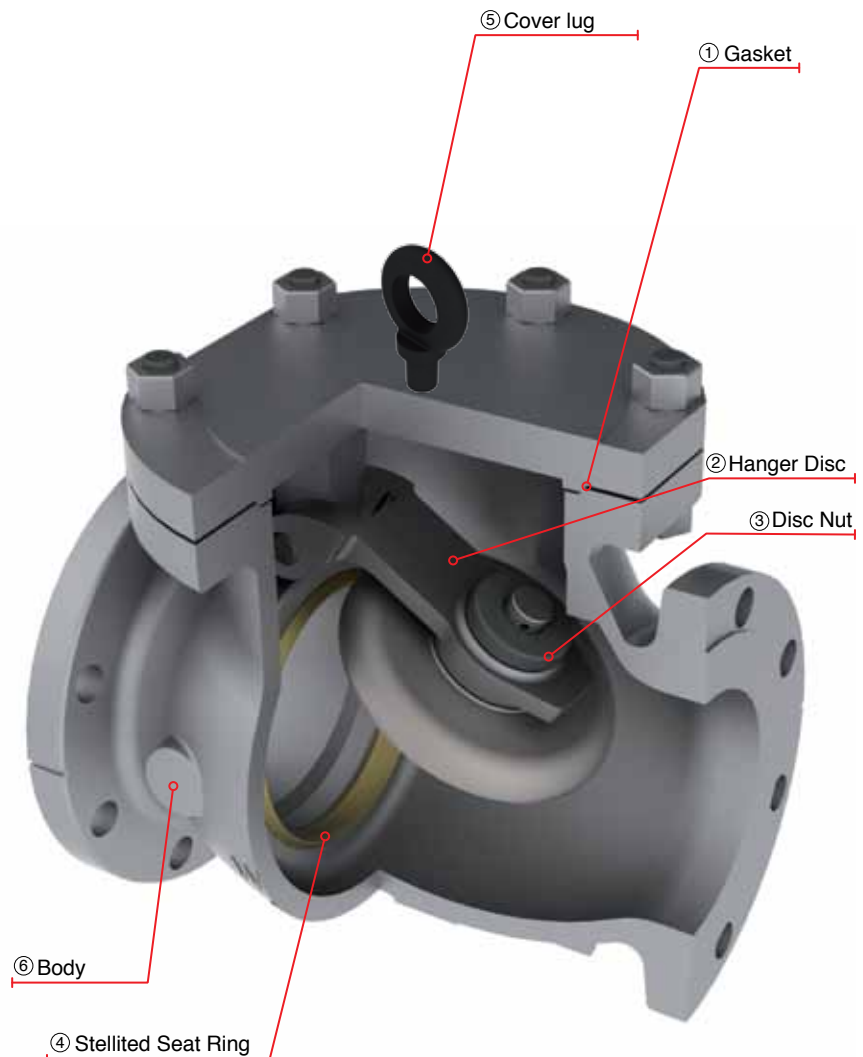

# WALWORTH CAST STEEL SWING CHECK VALVES, CLASS 150

- Design in accordance with API-6D & ASME B16.34
- Flange dimensions as per ASME B16.5
- End to end dimensions as per ASME B16.10
- WE dimensions as per ASME B 16.25
- Flange dimensions larger than 24" according to ASME B16.47 Series A as standard
- Flange dimensions as per ASME B16.47 Series B available upon request

Catalog Figure No.	ID Plant Figure No.	Type of Ends
5341RF	5341F	Flanged Raised Face
5341RTJ	5341RJ	Flanged Ring Type Joint
5341WE	5341WE	Buttweld

## Regular Bill of Materials

No.	DESCRIPTION	STANDARD MATERIAL
1	Body	ASTM A 216 GR WCB
2	Cover	ASTM A 216 GR WCB
3	Disc	A 216 GR WCB + 13% Cr.
4	Seat Ring	ASTM A 515 GR 70 + ST 6
5	Hanger	ASTM A 216 GR WCB
6	Hanger Pin	ASTM A 276 Type 410
7	Cover Gasket	Graphite/Stainless 316
8	Cover Stud	ASTM A 193 GR B7
9	Cover Stud Nut	ASTM A 194 GR 2H
10	Disc Nut	Alloy Steel
*11	Body Plug	Alloy Steel
*12	Identification Plate	Stainless Steel
**13	Coverlug	Commercial Steel

\*Not shown \*\*Only from 8" and up

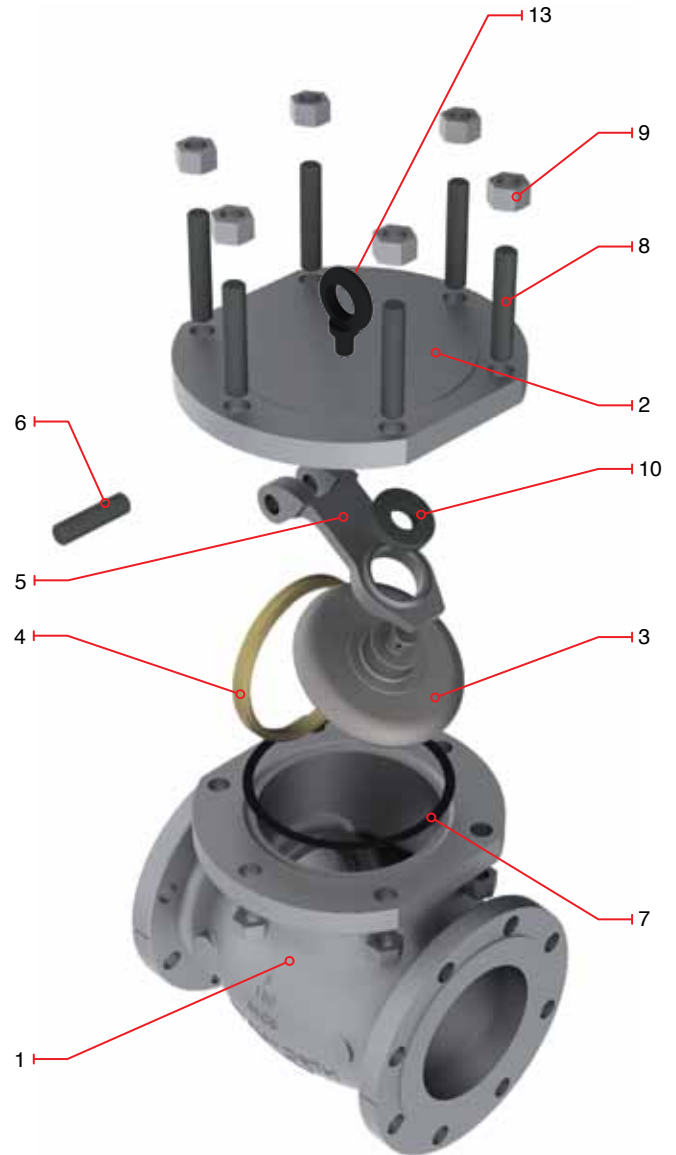

# WALWORTH CAST STEEL SWING CHECK VALVES, CLASS 150



- Design in accordance with API-6D & ASME B16.34
- Flange dimensions as per ASME B16.5
- End to end dimensions as per ASME B16.10
- WE dimensions as per ASME B 16.25
- Flange dimensions larger than 24" according to ASME B16.47 Series A as standard
- Flange dimensions as per ASME B16.47 Series B available upon request

Catalog Figure No.	ID Plant Figure No.	Type of Ends
5341RF	5341F	Flanged Raised Face
5341RTJ	5341RJ	Flanged Ring Type Joint
5341WE	5341WE	Buttweld

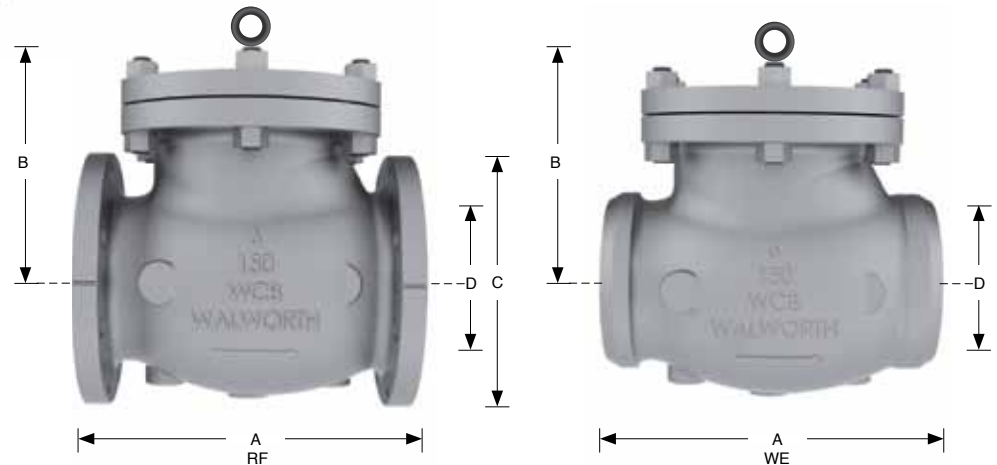

## Dimensions and Weights

D		51	64	76	102	152	203	254	305	356	406	457	508	610	762	914	1067	1219
Nominal Diameter	mm.	51	64	76	102	152	203	254	305	356	406	457	508	610	762	914	1067	1219
	inch	2	2 1/2	3	4	6	8	10	12	14	16	18	20	24	30	36	42	48
A (RF y WE)	mm.	203	216	241	292	356	495	622	699	787	864	978	978	1295	1524	1956	POA	POA
	inch	8	8 1/2	9 1/2	11 1/2	14	19 1/2	24 1/2	27 1/2	31	34	38 1/2	38 1/2	51	60	77	POA	POA
B	mm.	134	156	162	205	238	291	349	381	457	502	573	606	702	1003	1118	POA	POA
	inch	5 9/32	6 1/8	6 3/8	8 1/16	9 3/8	11 7/16	13 3/4	15	18	19 3/4	22 9/16	23 7/8	27 5/8	39.5	44	-	-
C	mm.	152	178	191	229	279	343	406	483	533	597	635	699	813	984	1168	1346	1511
	inch	6	7	7 1/2	9	11	13 1/2	16	19	21	23 1/2	25	27 1/2	32	38.75	46	53	59.5
Weight 5341RF	kg.	15	21	27	40	69	172	266	399	388	510	600	918	1160	1816	3632	POA	POA
	lb.	33	46.2	59.4	88	151.8	378.4	585.2	877.8	853.6	1122	1320	2019.6	2552	4000	8000	POA	POA
Weight 5341WE	kg.	13	19	17	36	64	132	210	305	318	418	492	753	951	1489	2978	POA	POA
	lb.	28.6	41.8	37.4	79.2	140.8	290.4	462	671	700	920	1082	1656	2093	3276	6552	POA	POA

# WALWORTH CAST STEEL SWING CHECK VALVES CLASS 300

## CAST STEEL SWING CHECK VALVES

### DESIGN FEATURES

- Swing check valves design in accordance with API-6D & ASME B16.34.
- Swing check valves option in accordance with API-603 only for stainless steel & Nickel alloys.
- Swing check valves for cryogenic service in accordance with BS-6364.
- Flange dimensions in accordance with ASME B16.5 for valves up to 24" nominal diameter.
- Damper & Counter weight options.
- Drain connections as per Customer request.
- Low fugitive emissions control.
- NACE service either MR-01-75 or MR-01-03.
- Test in accordance with API-598.

① Body to Cover Joint designed to apply a uniform load to the gasket to assure a leak proof seal.

② Disc to Hanger connection allows the disc a controlled movement independent of the hanger to assure proper disc alignment with the seat at closure.

③ The connection is secured by a welded disc nut to prevent disassembly due to vibration and closure impact.

④ Stellite Seat Ring provides increased resistance to wear abrasion and erosion of the sealing surface.

⑤ From 8" and up, WALWORTH check valves have coverlug for easy installation

⑥ Body with heavy wall thickness as per ASME B16.34 for maximum service life. Provided with bosses for optional drains.

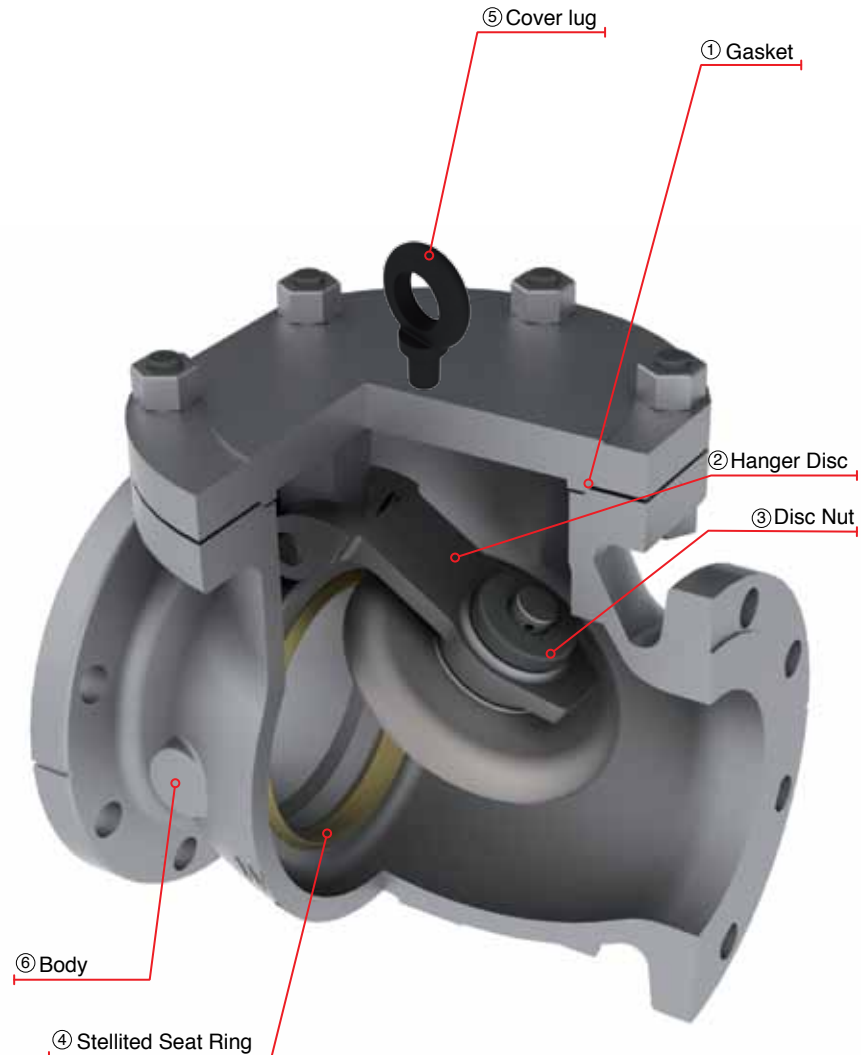



# WALWORTH CAST STEEL SWING CHECK VALVES CLASS 300

- Design in accordance with API-6D & ASME B16.34
- Flange dimensions as per ASME B16.5
- End to end dimensions as per ASME B16.10
- WE dimensions as per ASME B 16.25
- Flange dimensions larger than 24" according to ASME B16.47 Series A as standard
- Flange dimensions as per ASME B16.47 Series B available upon request

Catalog Figure No.	ID Plant Figure No.	Type of Ends
5344RF	5344F	Flanged Raised Face
5344RTJ	5344RJ	Flanged Ring Type Joint
5344WE	5344WE	Buttweld

## Regular Bill of Materials

No.	DESCRIPTION	STANDARD MATERIAL
1	Body	ASTM A 216 GR WCB
2	Cover	ASTM A 216 GR WCB
3	Disc	ASTM A 216 GR WCB + 13% Cr.
4	Seat Ring	ASTM A 515 GR 70 + ST 6
5	Hanger	ASTM A 216 GR WCB
6	Hanger Pin	ASTM A 276 Type 410
7	Cover Gasket	Spiral Stainless 304/Graphite
8	Cover Stud	ASTM A 193 GR B7
9	Cover Stud Nut	ASTM A 194 GR 2H
10	Disc Nut	Alloy Steel
*11	Body Plug	Alloy Steel
*12	Identification Plate	Stainless Steel
**13	Cover lug	Commercial Steel

\*Not Shown \*\* Only from 8" an up

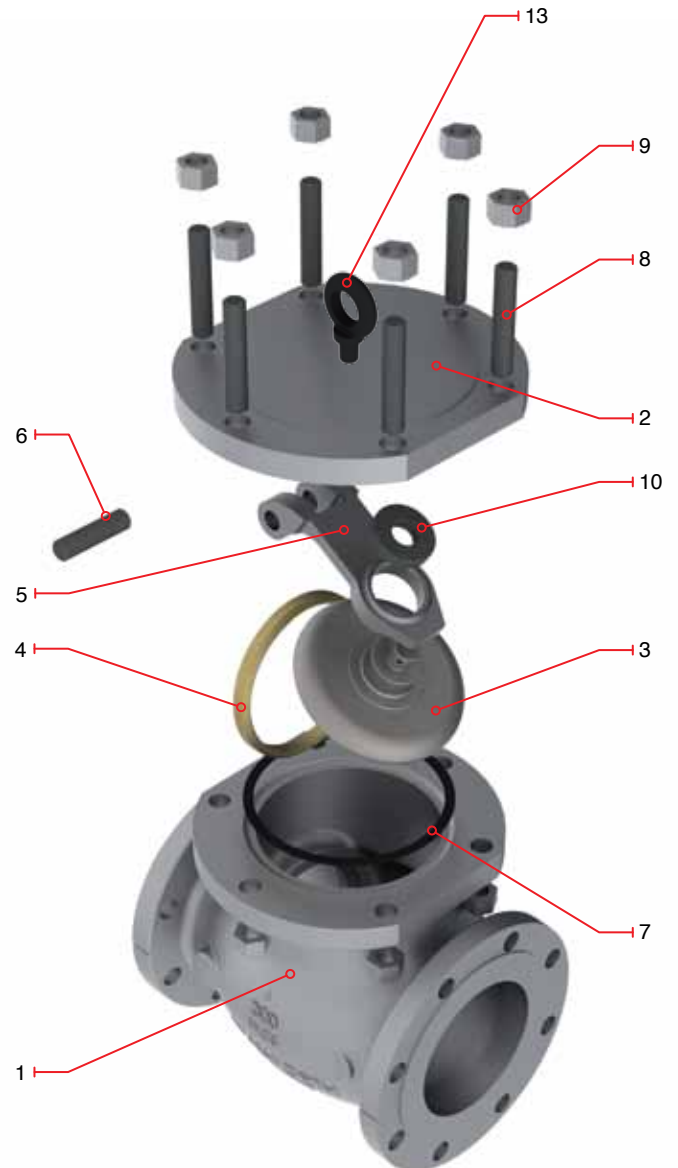

# WALWORTH CAST STEEL SWING CHECK VALVES CLASS 300



- Design in accordance with API-6D & ASME B16.34
- Flange dimensions as per ASME B16.5
- End to end dimensions as per ASME B16.10
- WE dimensions as per ASME B 16.25
- Flange dimensions larger than 24" according to ASME B16.47 Series A as standard
- Flange dimensions as per ASME B16.47 Series B available upon request

Catalog Figure No.	ID Plant Figure No.	Type of Ends
5344RF	5344F	Flanged Raised Face
5344RTJ	5344RJ	Flanged Ring Type Joint
5344WE	5344WE	Buttweld



## Dimensions and Weights

D																	
Nominal Diameter	mm.	51	64	76	102	152	203	254	305	356	406	457	508	610	762	914	
	inch	2	2 1/2	3	4	6	8	10	12	14	16	18	20	24	30	36	
A (RF y WE)	mm.	267	292	318	356	445	533	622	711	838	864	978	1016	1346	1594	2083	
	inch	10 1/2	11 1/2	12 1/2	14	17 1/2	21	24 1/2	28	33	34	38 1/2	40	53	62 3/4	82	
B	mm.	144	179	184	221	260	348	395	456	495	630	680	710	787	1029	1219	
	inch	5 11/16	7 1/16	7 1/4	8 11/16	10 1/4	13 11/16	15 9/16	17 15/16	19 1/2	24 13/16	26 3/4	27 15/16	31	40 1/2	48	
C	mm.	165	191	210	254	318	381	445	521	584	648	711	775	914	1092	1270	
	inch	6 1/2	7 1/2	8 1/4	10	12 1/2	15	17 1/2	20 1/2	23	25 1/2	28	30 1/2	36	43	50	
Weight	kg.	22	27	42	63	129	235	358	544	577	768	990	1136	2180	3000	5400	
5344RF	lb.	48	59	92	139	284	517	788	1197	1269	1690	2178	2499	4796	6600	11880	
Weight	kg.	19	25	31	58	95	159	305	470	531	707	911	1045	2006	2760	4968	
5344WE	lb.	41.8	54.648	68.2	127.6	209	349.8	671	1034	1168	1554	2004	2299	4412	6072	10930	

# WALWORTH CAST STEEL SWING CHECK VALVES CLASS 600

## CAST STEEL SWING CHECK VALVES

### DESIGN FEATURES

- Swing check valves design in accordance with API-6D & ASME B16.34.
- Swing check valves option in accordance with API-603 only for stainless steel & Nickel alloys.
- Swing check valves for cryogenic service in accordance with BS-6364.
- Flange dimensions in accordance with ASME B16.5 for valves up to 24" nominal diameter.
- Damper & Counter weight options.
- Drain connections as per Customer request.
- Low fugitive emissions control.
- NACE service either MR-01-75 or MR-01-03.
- Test in accordance with API-598.

- ① Body to Cover Joint designed to apply a uniform load to the gasket to assure a leak proof seal.
- ② Disc to Hanger connection allows the disc a controlled movement independent of the hanger to assure proper disc alignment with the seat at closure.
- ③ The connection is secured by a welded disc nut to prevent disassembly due to vibration and closure impact.
- ④ Stellite Seat Ring provides increased resistance to wear abrasion and erosion of the sealing surface.
- ⑤ From 8" and up, WALWORTH check valves have cover lug for easy installation
- ⑥ Body with heavy wall thickness as per ASME B16.34 for maximum service life. Provided with bosses for optional drains.

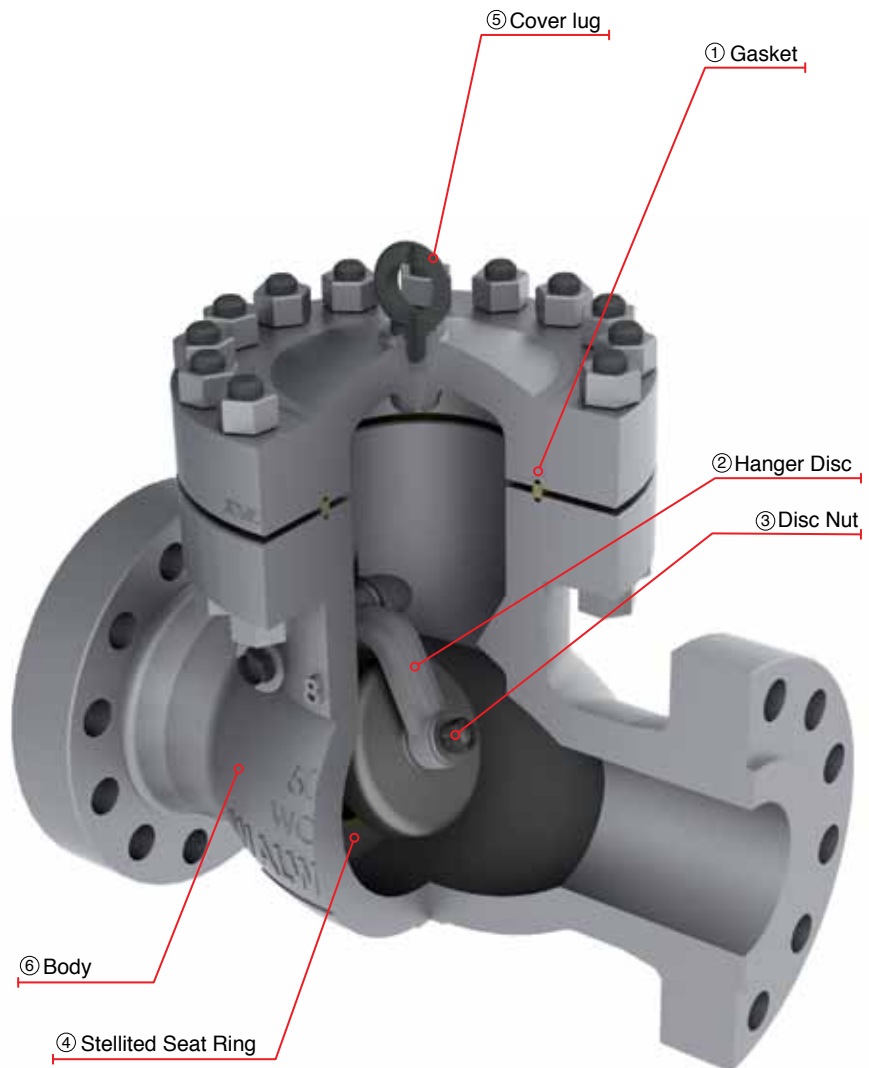

# WALWORTH CAST STEEL SWING CHECK VALVES CLASS 600

- Design in accordance with API-6D & ASME B16.34
- Flange dimensions as per ASME B16.5
- End to end dimensions as per ASME B16.10
- WE dimensions as per ASME B 16.25
- Flange dimensions larger than 24" according to ASME B16.47 Series A as standard
- Flange dimensions as per ASME B16.47 Series B available upon request

Catalog Figure No.	ID Plant Figure No.	Type of Ends
5350RF	5350F	Flanged Raised Face
5350RTJ	5350RJ	Flanged Ring Type Joint
5350WE	5350WE	Buttweld

## Regular Bill of Materials

No.	DESCRIPTION	WCB Trim UT
1	Body	ASTM A 216 GR WCB
2	Cover	ASTM A 216 GR WCB
3	Disc	ASTM A 216 GR WCB + 13% Cr.
4	Seat Ring	ASTM A 515 GR 70 + ST 6
5	Hanger	ASTM A 216 GR WCB
6	Hanger Pin	ASTM A 276 Type 410
7	Ring Type Joint Gasket	ASTM A 108 GR 1010
8	Cover Stud	ASTM A 193 GR B7
9	Cover Stud Nut	ASTM A 194 GR 2H
10	Disc Washer	ASTM A 276 Type 410
11	Disc Nut	Alloy Steel
12	Body Plug	Alloy Steel
*13	Identification Plate	Stainless Steel
14	Hanger retainer	Stainless Steel
15	Coverlug	Commercial Steel

\*Not Shown

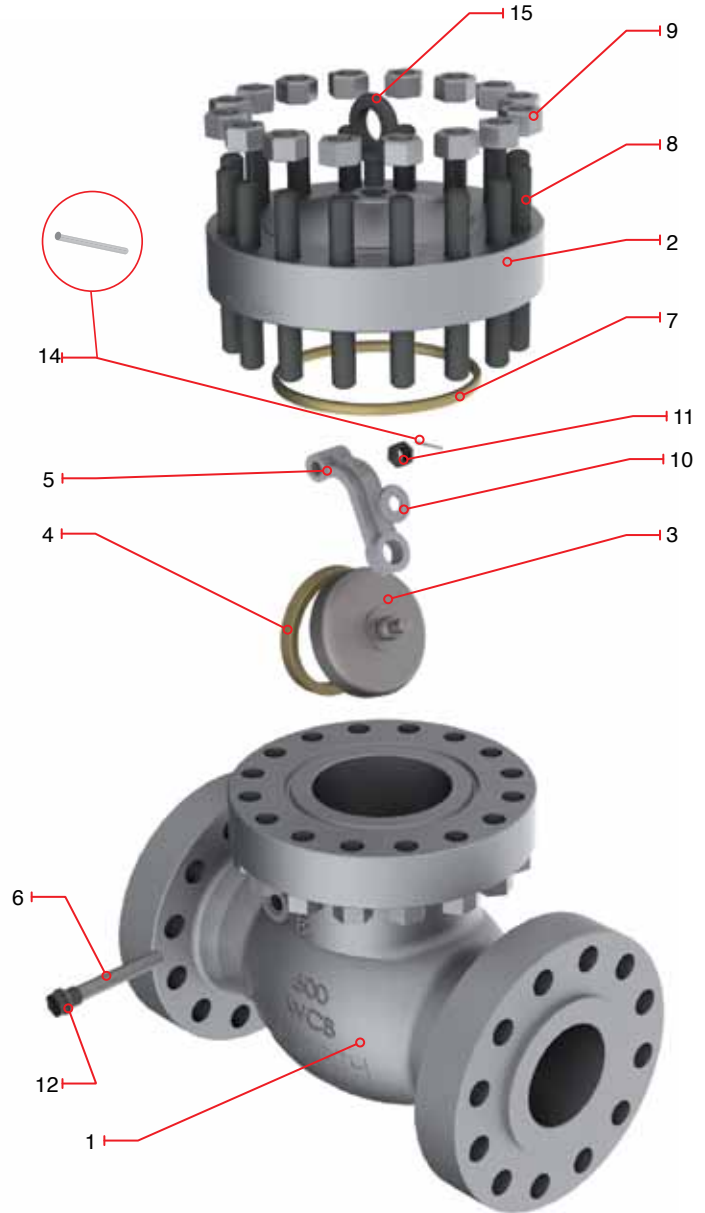

# WALWORTH CAST STEEL SWING CHECK VALVES CLASS 600



- Design in accordance with API-6D & ASME B16.34
- Flange dimensions as per ASME B16.5
- End to end dimensions as per ASME B16.10
- WE dimensions as per ASME B 16.25
- Flange dimensions larger than 24" according to ASME B16.47 Series A as standard
- Flange dimensions as per ASME B16.47 Series B available upon request

Catalog Figure No.	ID Plant Figure No.	Type of Ends
5350RF	5350F	Flanged Raised Face
5350RTJ	5350RJ	Flanged Ring Type Joint
5350WE	5350WE	Buttweld

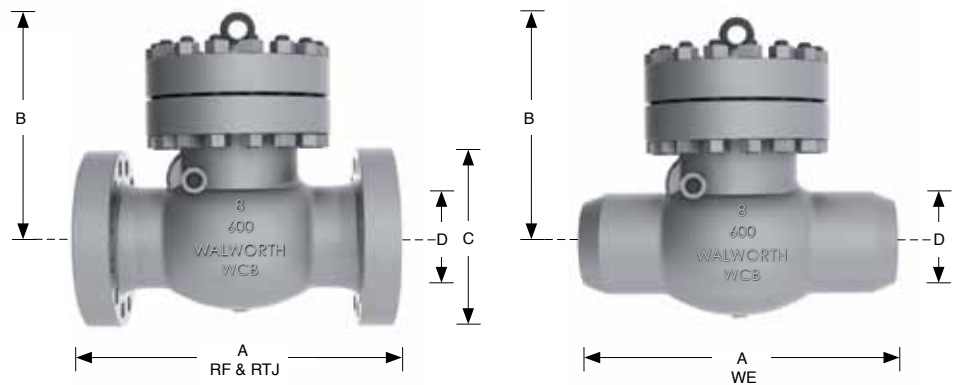

## Dimensions and Weights

D																		
Nominal Diameter	mm.	51	64	76	102	152	203	254	305	356	406	457	508	610	762	914		
	inch	2	2 1/2	3	4	6	8	10	12	14	16	18	20	24	30	36		
A (RF y WE)	mm.	292	330	356	432	559	660	787	838	889	991	1092	1194	1397	1651	2083		
	inch	11 1/2	13	14	17	22	26	31	33	35	39	43	47	55	65	82		
A* (RTJ)	mm.	295	333	359	435	562	663	790	841	892	994	1095	1200	1407	1664	POA		
	inch	11 5/8	13 1/8	14 1/8	17 1/8	22 1/8	26 1/8	31 1/8	33 1/8	35 1/8	39 1/8	43 1/8	47 1/4	55 3/8	65 1/2	POA		
B	mm.	147	182	177	241	344	435	512	575	576	653	752	715	787	1092	1422		
	inch	5 3/4	7 3/16	6 15/16	9 1/2	13 9/16	17 1/8	20 3/16	22 5/8	22 11/16	25 11/16	29 5/8	28 1/8	31	43	56		
C	mm.	165	191	210	273	356	419	508	559	603	686	743	813	940	1130	1314		
	inch	6 1/2	7 1/2	8 1/4	10 3/4	14	16 1/2	20	22	23 3/4	27	29 1/4	32	37	44 1/2	51 3/4		
Weight	kg.	25	40	46	85	173	383	567	770	1250	1735	2006	2780	4310	5800	10500		
5350RF	lb.	55	88	101.2	187	380.6	842.6	1247.4	1694	2750	3817	4413.2	6116	9482	12760	23100		
Weight	kg.	21	34	39	72	147	337	499	678	1125	1562	1805	2502	3879	5220	9450		
5350WE	lb.	47	75	86	159	324	741	1098	1491	2475	3435	3972	5504	8534	11484	20790		

# WALWORTH CAST STEEL SWING CHECK VALVES CLASS 900

## CAST STEEL SWING CHECK VALVES

### DESIGN FEATURES

- Swing check valves design in accordance with API-6D & ASME B16.34.
- Swing check valves option in accordance with API-603 only for stainless steel & Nickel alloys.
- Swing check valves for cryogenic service in accordance with BS-6364.
- Flange dimensions in accordance with ASME B16.5 for valves up to 24" nominal diameter.
- Damper & Counter weight options.
- Drain connections as per Customer request.
- Low fugitive emissions control.
- NACE service either MR-01-75 or MR-01-03.
- Test in accordance with API-598.

- ① Body to Cover Joint designed to apply a uniform load to the gasket to assure a leak proof seal.
- ② Disc to Hanger connection allows the disc a controlled movement independent of the hanger to assure proper disc alignment with the seat at closure.
- ③ The connection is secured by a welded disc nut to prevent disassembly due to vibration and closure impact.
- ④ Stellite Seat Ring provides increased resistance to wear abrasion and erosion of the sealing surface.
- ⑤ From 8" and up, WALWORTH check valves have coverlug for easy installation
- ⑥ Body with heavy wall thickness as per ASME B16.34 for maximum service life. Provided with bosses for optional drains.

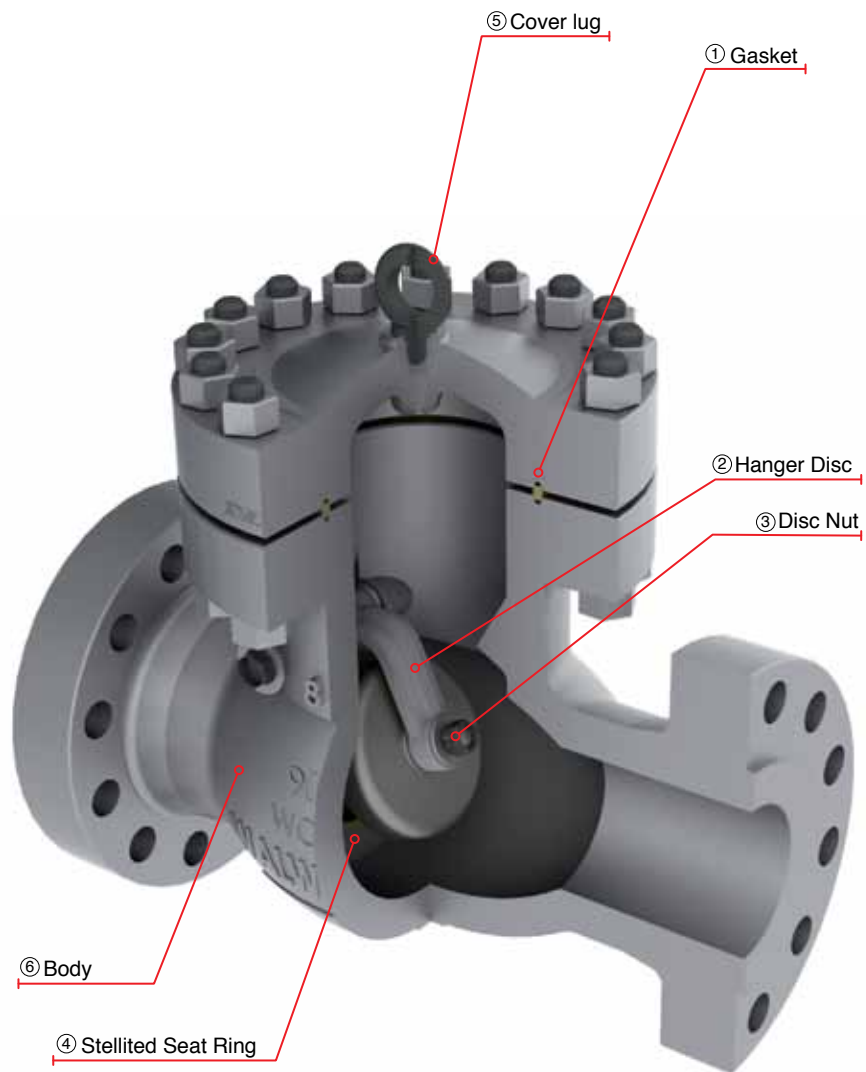

# WALWORTH CAST STEEL SWING CHECK VALVES CLASS 900

- Design in accordance with API-6D & ASME B16.34
- Flange dimensions as per ASME B16.5
- End to end dimensions as per ASME B16.10
- WE dimensions as per ASME B 16.25
- Flange dimensions larger than 24" according to ASME B16.47 Series A as standard
- Flange dimensions as per ASME B16.47 Series B available upon request

Catalog Figure No.	ID Plant Figure No.	Type of Ends
5353RF	5353F	Flanged Raised Face
5353RTJ	5353RJ	Flanged Ring Type Joint
5353WE	5353WE	Buttweld

## Regular Bill of Materials

No.	DESCRIPTION	WCB Trim UT
1	Body	ASTM A 216 GR WCB
2	Cover	ASTM A 216 GR WCB
3	Disc	ASTM A 216 GR WCB + 13% Cr.
4	Seat Ring	ASTM A 515 GR 70 + ST 6
5	Hanger	ASTM A 216 GR WCB
6	Hanger Pin	ASTM A 276 Type 410
7	Ring Type Joint Gasket	ASTM A 108 GR 1010
8	Cover Stud	ASTM A 193 GR B7
9	Cover Stud Nut	ASTM A 194 GR 2H
10	Disc Washer	ASTM A 276 Type 410
11	Disc Nut	Alloy Steel
12	Body Plug	Alloy Steel
*13	Identification Plate	Stainless Steel
14	Hanger retainer	Stainless Steel
15	Cover lug	Commercial Steel

\*Not Shown

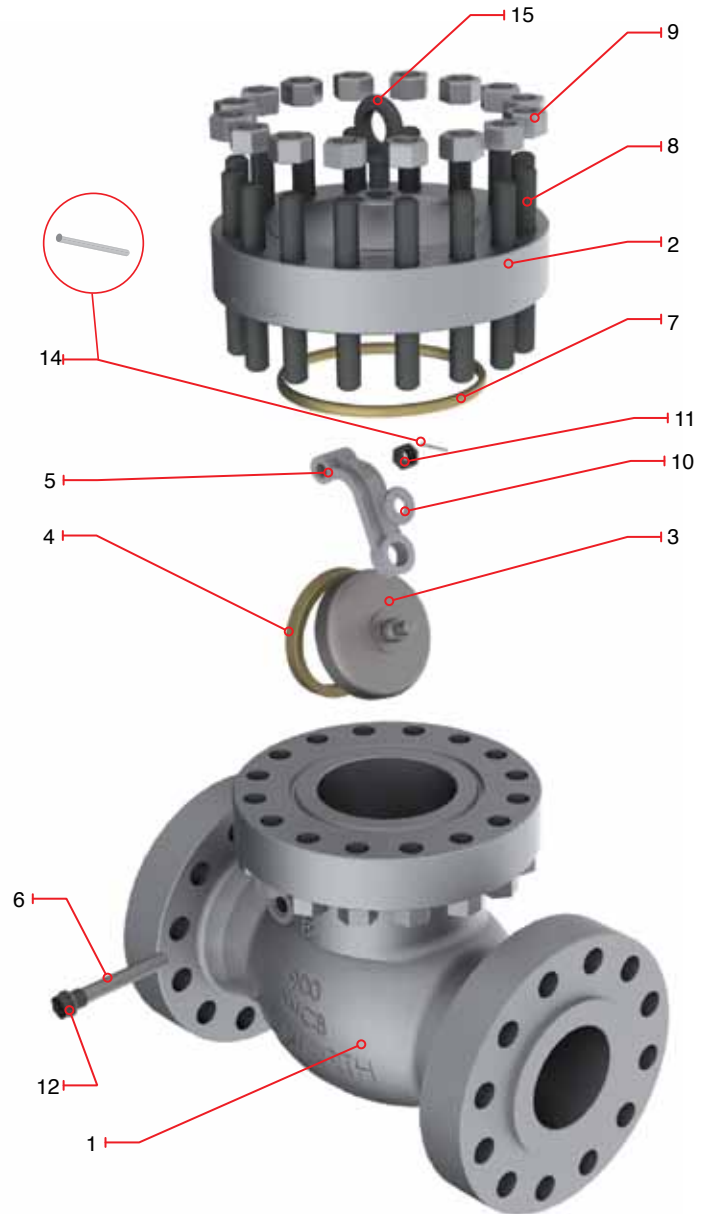

# WALWORTH CAST STEEL SWING CHECK VALVES CLASS 900



- Design in accordance with API-6D & ASME B16.34
- Flange dimensions as per ASME B16.5
- End to end dimensions as per ASME B16.10
- WE dimensions as per ASME B 16.25
- Flange dimensions larger than 24" according to ASME B16.47 Series A as standard
- Flange dimensions as per ASME B16.47 Series B available upon request

Catalog Figure No.	ID Plant Figure No.	Type of Ends
5353RF	5353F	Flanged Raised Face
5353RTJ	5353RJ	Flanged Ring Type Joint
5353WE	5353WE	Buttweld

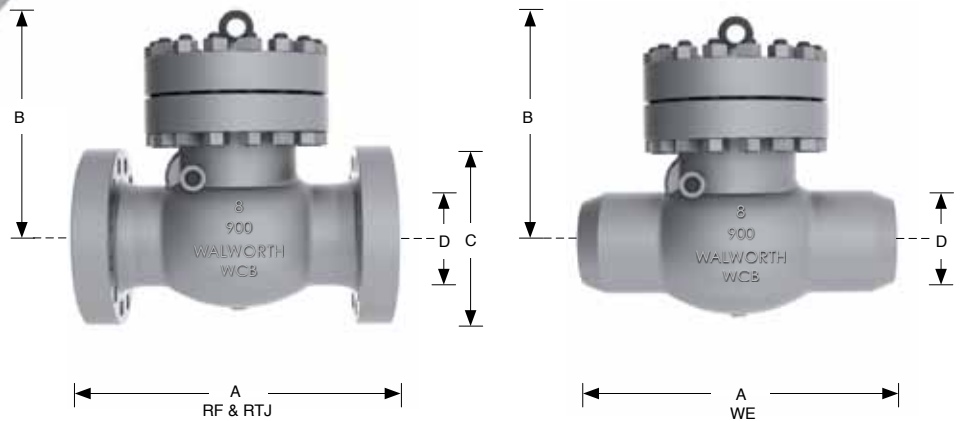

## Dimensions and Weights

D													
Nominal Diameter	mm.	51	76	102	152	203	254	305	356	406	457	508	610
	inch	2	3	4	6	8	10	12	14	16	18	20	24
A (RF y WE)	mm.	368	381	457	610	737	838	965	1029	1130	1219	1321	1549
	inch	14 1/2	15	18	24	29	33	38	40 1/2	44 1/2	48	52	61
A* (RTJ)	mm.	371	384	460	613	740	841	968	1038	1140	1232	1334	1568
	inch	14 5/8	15 1/8	18 1/8	24 1/8	29 1/8	33 1/8	38 1/8	40 7/8	44 7/8	48 1/2	52 1/2	61 3/4
B	mm.	255	266	292	396	545	528	595	635	POA	POA	POA	POA
	inch	10	10 1/2	11 1/2	15 9/16	21 7/16	20 13/16	23 7/16	25	POA	POA	POA	POA
C	mm.	216	241	292	381	470	546	610	641	705	787	857	1041
	inch	8 1/2	9 1/2	11 1/2	15	18 1/2	21 1/2	24	25 1/4	27 3/4	31	33 3/4	41
Weight		64	93	127	263	505	1235	1450	1480	POA	POA	POA	POA
5353RF	kg.	141	205	279	579	1111	2717	3190	3256	POA	POA	POA	POA
Weight	kg.	54	79	108	224	429	1087	1276	1285	POA	POA	POA	POA
5353WE	lb.	120	174	237	492	944	2391	2807	2827	POA	POA	POA	POA



# WALWORTH CAST STEEL SWING CHECK VALVES CLASS 1500

## CAST STEEL SWING CHECK VALVES

### DESIGN FEATURES

- Swing check valves design in accordance with API-6D & ASME B16.34.
- Swing check valves option in accordance with API-603 only for stainless steel & Nickel alloys.
- Swing check valves for cryogenic service in accordance with BS-6364.
- Flange dimensions in accordance with ASME B16.5 for valves up to 24" nominal diameter.
- Damper & Counter weight options.
- Drain connections as per Customer request.
- Low fugitive emissions control.
- NACE service either MR-01-75 or MR-01-03.
- Test in accordance with API-598.

① Body to Cover Joint designed to apply a uniform load to the gasket to assure a leak proof seal.

② Disc to Hanger connection allows the disc a controlled movement independent of the hanger to assure proper disc alignment with the seat at closure.

③ The connection is secured by a welded disc nut to prevent disassembly due to vibration and closure impact.

④ Stellite Seat Ring provides increased resistance to wear abrasion and erosion of the sealing surface.

⑤ From 8" and up, WALWORTH check valves have coverlug for easy installation

⑥ Body with heavy wall thickness as per ASME B16.34 for maximum service life. Provided with bosses for optional drains.

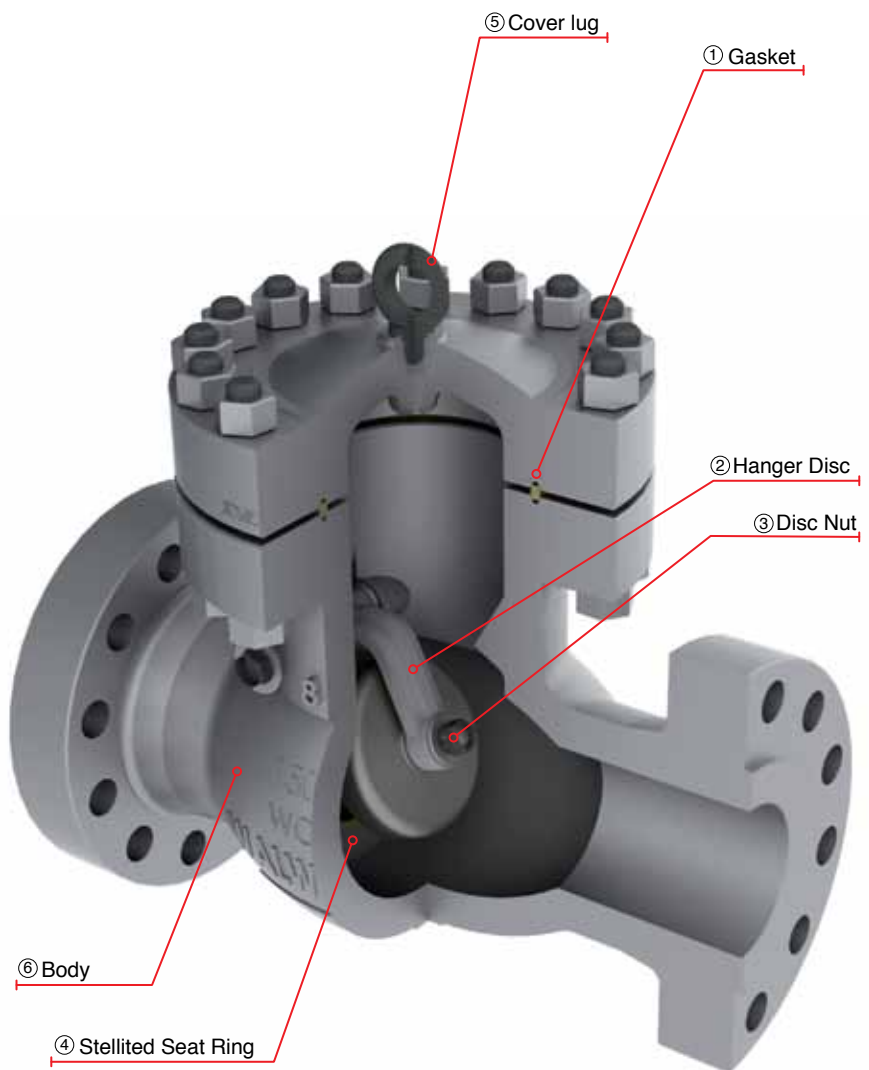

# WALWORTH CAST STEEL SWING CHECK VALVES CLASS 1500

- Design in accordance with API-6D & ASME B16.34.
- Flange dimensions as per ASME B16.5
- End to end dimensions as per ASME B16.10
- WE dimensions as per ASME B 16.25
- Flange dimensions larger than 24" according to ASME B16.47 Series A as standard
- Flange dimensions as per ASME B16.47 Series B available upon request

Catalog Figure No.	ID Plant Figure No.	Type of Ends
5356RF	5356F	Flanged Raised Face
5356RTJ	5356RJ	Flanged Ring Type Joint
5356WE	5356WE	Buttweld

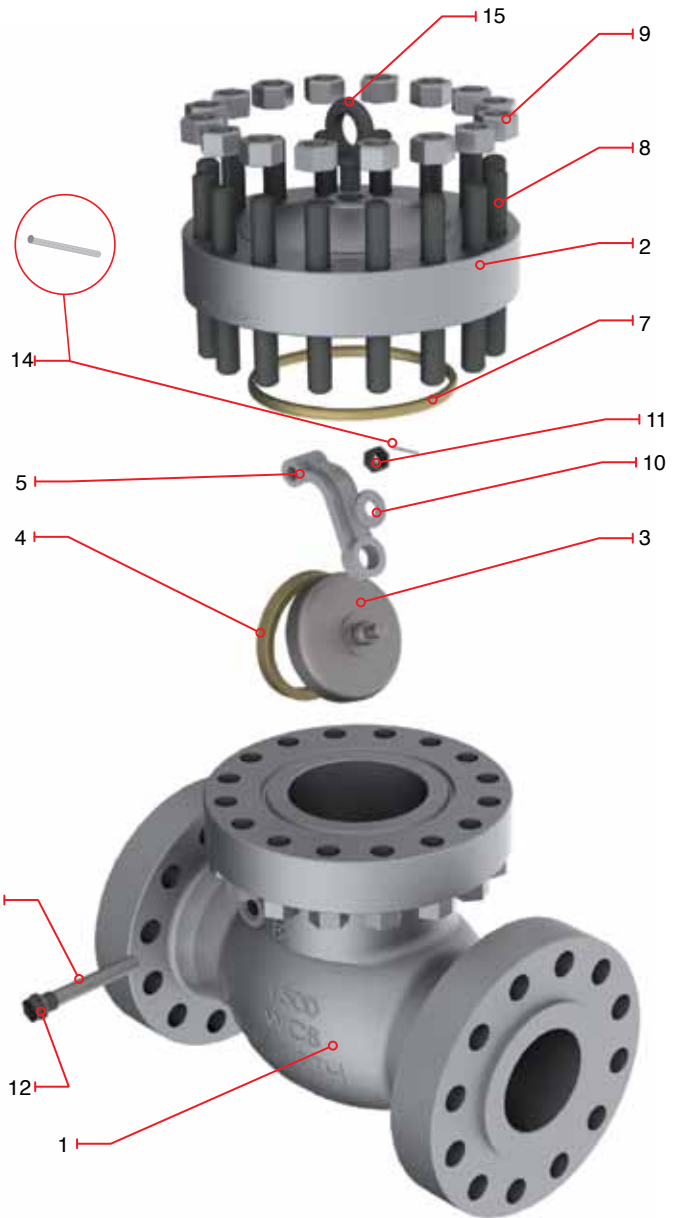

## Regular Bill of Materials

No.	DESCRIPTION	WCB Trim UT
1	Body	ASTM A 216 GR WCB
2	Cover	ASTM A 216 GR WCB
3	Disc	ASTM A 216 GR WCB + 13% Cr.
4	Seat Ring	ASTM A 515 GR 70 + ST 6
5	Hanger	ASTM A 216 GR WCB
6	Hanger Pin	ASTM A 276 Type 410
7	Ring Type Joint Gasket	ASTM A 108 GR 1010
8	Cover Stud	ASTM A 193 GR B7
9	Cover Stud Nut	ASTM A 194 GR 2H
10	Disc Washer	ASTM A 276 Type 410
11	Disc Nut	Alloy Steel
12	Body Plug	Alloy Steel
*13	Identification Plate	Stainless Steel
14	Hanger retainer	Stainless Steel
15	Cover lug	Commercial Steel

\*Not Shown

# WALWORTH CAST STEEL SWING CHECK VALVES, CLASS 1500



- Design in accordance with API-6D & ASME B16.34
- Flange dimensions as per ASME B16.5
- End to end dimensions as per ASME B16.10
- WE dimensions as per ASME B 16.25

Catalog Figure No.	ID Plant Figure No.	Type of Ends
5356RF	5356F	Flanged Raised Face
5356RTJ	5356RJ	Flanged Ring Type Joint
5356WE	5356WE	Buttweld

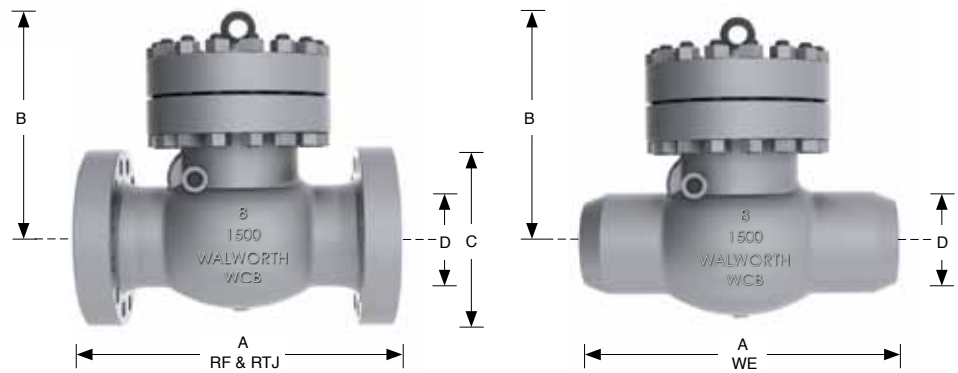

## Dimensions and Weights

D															
Nominal Diameter	mm. / inch	51	64	76	102	152	203	508	305	356	406	457	508	610	
		2	2 1/2	3	4	6	8	10	12	14	16	18	20	24	
A (RF y WE)	mm.	368	419	470	546	705	832	991	1130	1257	1384	1537	1664	1943	
	inch	14 1/2	16 1/2	18 1/2	21 1/2	27 3/4	32 3/4	39	44 1/2	49 1/2	54 1/2	60 1/2	65 1/2	76 1/2	
A* (RTJ)	mm.	371	422	473	549	711	842	1000	1146	1276	1407	1559	1686	1972	
	inch	14 5/8	16 5/8	18 5/8	21 5/8	28	33 1/8	39 3/8	45 1/8	50 1/4	55 3/8	61 3/8	66 3/8	77 5/8	
B	mm.	255	297	297	336	328	563	605	730	857	883	1022	1162	POA	
	inch	10	11 11/16	11 11/16	13 1/4	12 15/16	22 3/16	23 13/16	28 3/4	33 3/4	34 3/4	40 1/4	45 3/4	POA	
C	mm.	216	244	267	311	394	483	584	673	749	826	914	984	1168	
	inch	8 1/2	9 5/8	10 1/2	12 1/4	15 1/2	19	23	26 1/2	29 1/2	32 1/2	36	38 3/4	46	
Weight 5356RF	kg.	64	127	127	211	418	777	1550	2100	2358	3400	4350	5500	POA	
	lb.	141	279	279	464	920	1709	3410	4620	5188	7480	9570	12100	POA	
Weight 5356WE	kg.	54	108	108	179	355	660	1318	1785	2004	2890	3698	4675	POA	
	lb.	120	237	237	395	782	1453	2899	3927	4409	6358	8135	10285	POA	

# TECHNICAL INFORMATION

## WEDGE DESIGNS

### Flexible wedge characteristics:

- Provides resistance to possible wedge/seat sticking from high temperature to low temperature fluctuations by compensating for the resulting small body/seat movement.
- Facilitates seating and sealing and assures a long wear life.
- Susceptible to build-up when used with fluids having high solids content.



### Solid wedge characteristics:

- More susceptible to wedge/seat “sticking” and difficulty in opening when closed hot and allowed to cool due to the resulting small body/seat movement.
- Less able to compensate for the normal wedge/seat wear over the long term.
- Will handle fluids with high solids content without difficulty.



## TECHNICAL INFORMATION

### LANTERN RING-CONDENSING CHAMBER

Walworth® API 600 valves can be provided with a stem packing/lantern ring combination of packing above and below the lantern ring to provide the ability to condense/vent material being processed.

The system can be utilized to lubricate the packing or to drain/purge the stem area to a leakage recovery system when liquids/gasses cannot be released to the atmosphere.

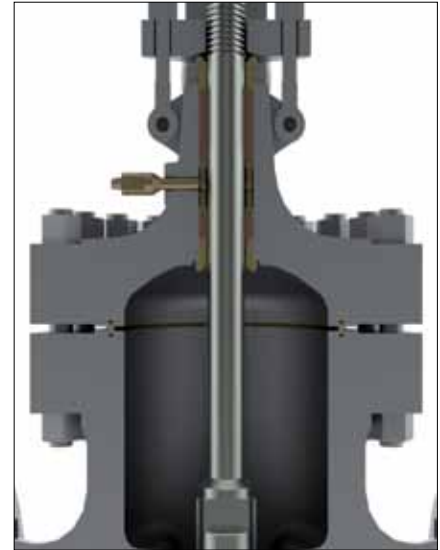

### NACE SERVICE VALVES

The National Association of Corrosion Engineers (NACE) establishes standards for materials resistant to Sulfide Stress Cracking (SSC) to be used in hydrogen sulfide (H<sub>2</sub>S) bearing hydrocarbon service.

NACE standard MR0175 defines a sulfide stress cracking region based on the relationship of H<sub>2</sub>S present to the total operating pressure.

This must be considered when specifying valves for service where H<sub>2</sub>S is present as proper selection of materials is a customer responsibility.

Sulfide stress cracking in materials not suitable for H<sub>2</sub>S service can result in a sudden failure with damage to equipment and harm to personnel.

#### Important considerations when specifying NACE service

1. Hydrogen ion concentration (Ph).
2. Concentration and total pressure of the hydrogen sulfide (H<sub>2</sub>S).
3. Concentration of water, carbon dioxide (CO<sub>2</sub>) and chlorides.
4. Service temperature.

The customer can select valves made of alloy/carbon steel material with controlled hardness and/or a stainless steel material depending on the severity of the fluid. Valves having a body/bonnet with a controlled hardness of Rc 22 and studs/nuts of B7M/2HM can be combined with a customer selected trim and manufactured to meet NACE MR0175 requirements.

# TECHNICAL INFORMATION

## STEM PACKING

Walworth® valves are designed, manufactured and tested to meet 50 PPM VOC fugitive emission leak rate as a standard off the shelf valve. This applies to all gate and globe valves, both Cast Steel and Forged Steel, without a requirement for a “special order”.

Walworth® uses a stem packing of flexible graphite incorporating a passive corrosion inhibitor in a combination of high and low density sealing rings with anti-extrusion end rings reinforced with Inconel wire.

The long term low emission stem sealing ability of Walworth® packing is enhanced by reduced diametral clearances and close control of stem straightness and packing sealing surface finish.

Walworth® can also provide gate and globe valves with a stem packing live loading system for installations requiring frequent valve operation and/or having large variations in temperature/pressure or where it is desirable to eliminate the need for occasional adjustment of the packing to compensate for the variations in operation. Live loading will provide a constant compression against the packing to maintain the optimum seal over a long period of time and variations in the operating conditions.

Walworth® can also supply valves with stem packing of different types and materials to meet the customer requirements.

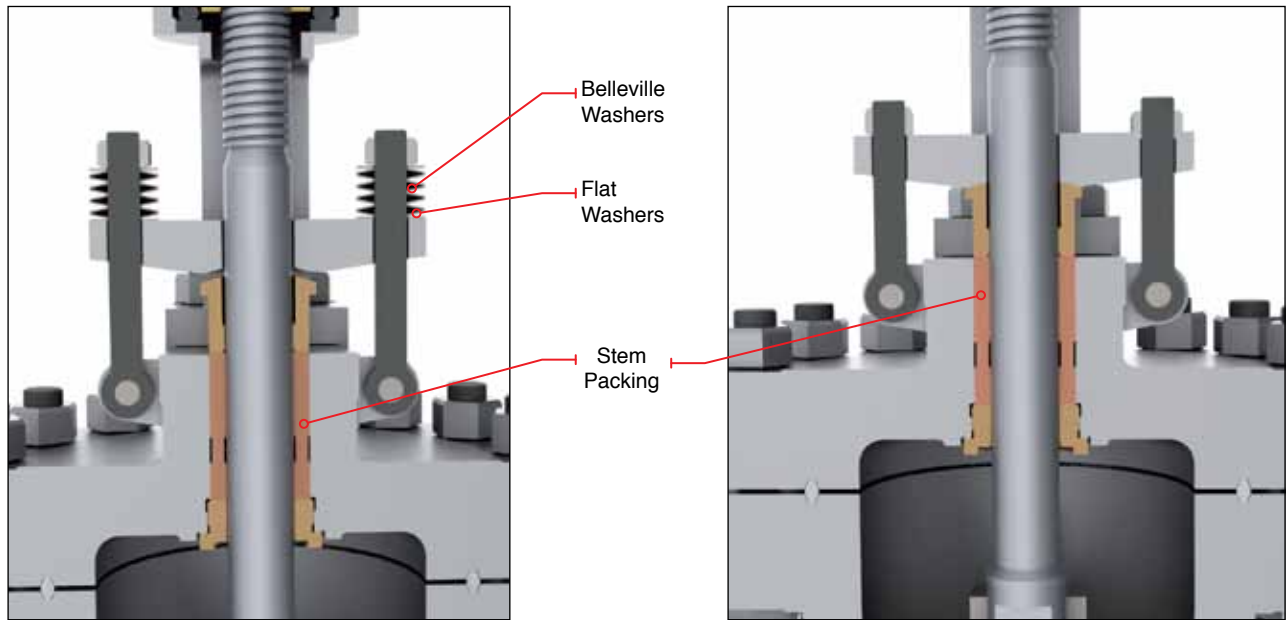

**Live Loading Stem Packing System**

**Standard Stem Packing System**

# TECHNICAL INFORMATION

## BODY AND BONNET JOINT SEAL GASKETS

Walworth® cast steel standard valves are supplied with the types of body/bonnet gaskets shown in the table. For special service conditions, Walworth® valves can also be supplied with special shapes on joints and special materials, to comply with specific requirements of the customer.

VALVE	CLASS				
	150	300	600	900	1500
GATE	1	2	3	3	3
GLOBE	1	2	3	3	3
CHECK	1	2	3	3	3

### FLAT GASKET



1.- FLAT GASKET: Graphite with 316 Stainless Steel Core



### SPIROLASTIC GASKET



1.- SPIROLASTIC GASKET: Stainless Steel / Graphite Filled



### RING GASKET



1.- FLAT GASKET: Oval or Octagonal shape. Soft or Stainless Steel

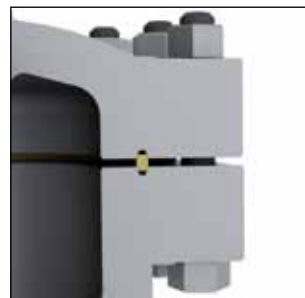

# TECHNICAL INFORMATION

## TYPES OF END CONNECTIONS

Walworth® cast steel valves can be supplied with flanged ends in raised face, flat faces or ring joint type as well as in welding ends (buttweld). They can also be supplied with combined ends, such as flanged by weld, in accordance to customer requirements.

The buttweld ends in standard valves are machined in accordance with ASME B 16.25 and are supplied to meet the following pipe schedules:

Valve Pressure Class	Weld End Pipe Schedule
150/300	Schedule 40 – 2" to 10" Standard Wall – 12" to 24"
600	Schedule 80
900	Schedule 160 – 2" to 3" Schedule 120 – 4" and Larger
1500	Schedule 160

The customer must clearly specify the pipe wall thickness and type of pipe to be welded to the valves for schedules different than the above.

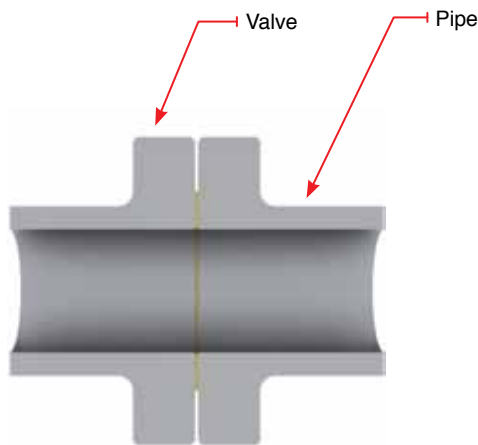

Flanged Ends  
Flat Face

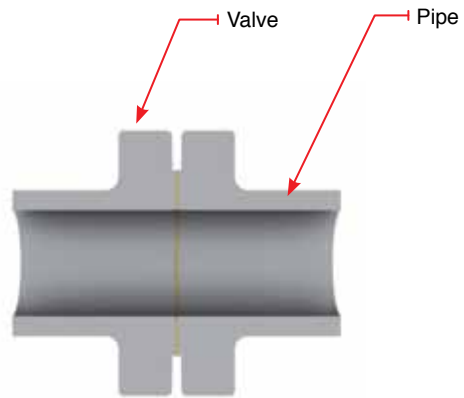

Flanged Ends  
Raised Face

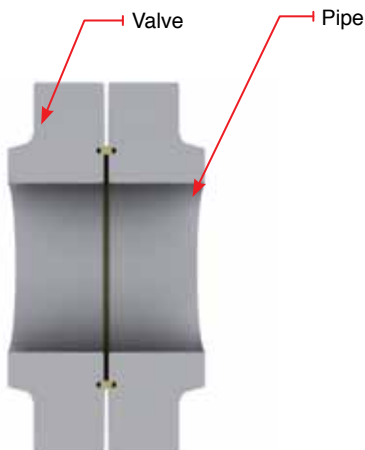

Flanged Ends  
Ring Type Joint

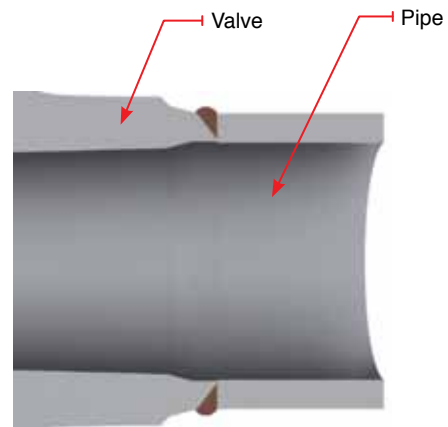

Weld Ends Buttweld



# TECHNICAL INFORMATION

## TYPE OF OPERATIONS

The Walworth® standard cast steel product line includes many different valves designed to meet most applications.

Special adaptations can be made to meet specific customer requirements. Valves can be supplied with manual handwheel/gear operation, chain wheel, as well as electric, pneumatic and hydraulic actuators.

This makes it possible for Walworth® to furnish valves adapted to the customers special needs such as controlled opening/closing and remote installation.

Valves can also be supplied with a bypass, drain or vent connection, stem extension, position indicators, floor stand mounting as well as a lever and weight system for swing check valves.

### Gear Operators

A manual gear operator is designed with a bevel gear and pinion ratio sized to transmit the required opening/closing torque with normal operator effort on the handwheel. They can be supplied as waterproof units and/or for underground installation with a square operating nut.



### Chain Wheel Operation

Chain Wheels are designed for operating valves installed in remote or inaccessible locations. They can (PHOTO) be furnished with roller guides to prevent the chain from jumping off the wheel. Impact type chain wheels are also available to assist in unseating a tightly closed valve



### Actuators

Valves can be furnished with either electric, pneumatic or hydraulic actuators. The actuators can be furnished as either waterproof and/or explosion proof. The customer must specify such things as open-close speed, maximum differential pressure, service temperature, type of voltage-phase-frequency, air or gas pressure for pneumatic actuators and flow characteristics for hydraulic actuators to be assured of correct performance.



# TECHNICAL INFORMATION

## ACCESSORIES

### Bypass, Drain and Vent Connections

A bypass line can be furnished with Walworth® cast steel valves for equalizing pressure around the main valve or for warming up the line before opening the main valve. Drain connections are normally located in the valve body to drain the valve when internal inspection or maintenance is required.

A vent connection can be located in the valve bonnet to relieve an over-pressure that could occur due to an expansion of trapped liquid. MSS SP-45 lists the standard locations and connection sizes for gate, globe and check valves



Nominal Size of Valve	2" to 4"	6" to 8"	10" and larger
Size of Bypass-Drain-Vent	1/2"	3/4"	1"

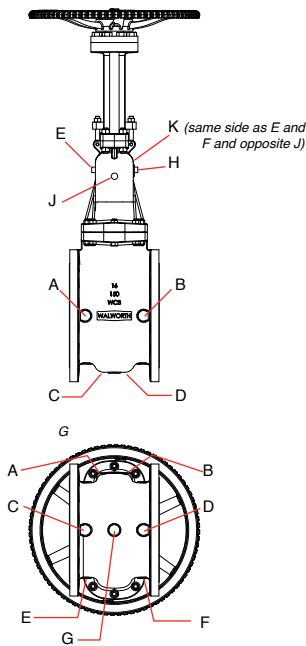

**Gate Valve**

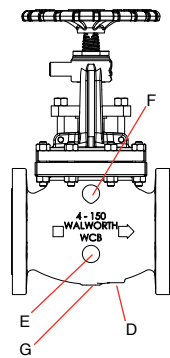
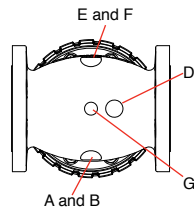

**Globe Valve**

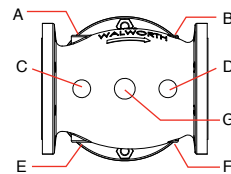
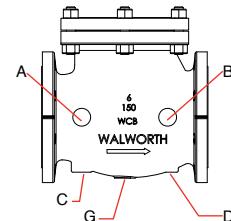
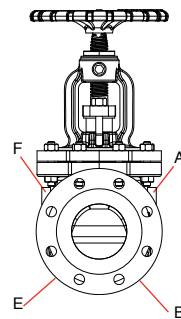

**Check Valve**

Bosses and drain connection positions in accordance with MSS-SP-45 & ASME B16.34 Standards

# TECHNICAL INFORMATION

## ACCESORIES

### Stem Extensions and Floor Stands

Stem extensions and floor stands are used to facilitate operation of a valve installed either underground, in a vault, or on a platform. These arrangements are available for either handwheel,

chainwheel or gear operation. The distance from the center of the valve port to the top of the stem or center line of the gear operator must be specified for stem extensions. The distance from the center of the valve port to the floor level must be specified for a floor stand mounting.

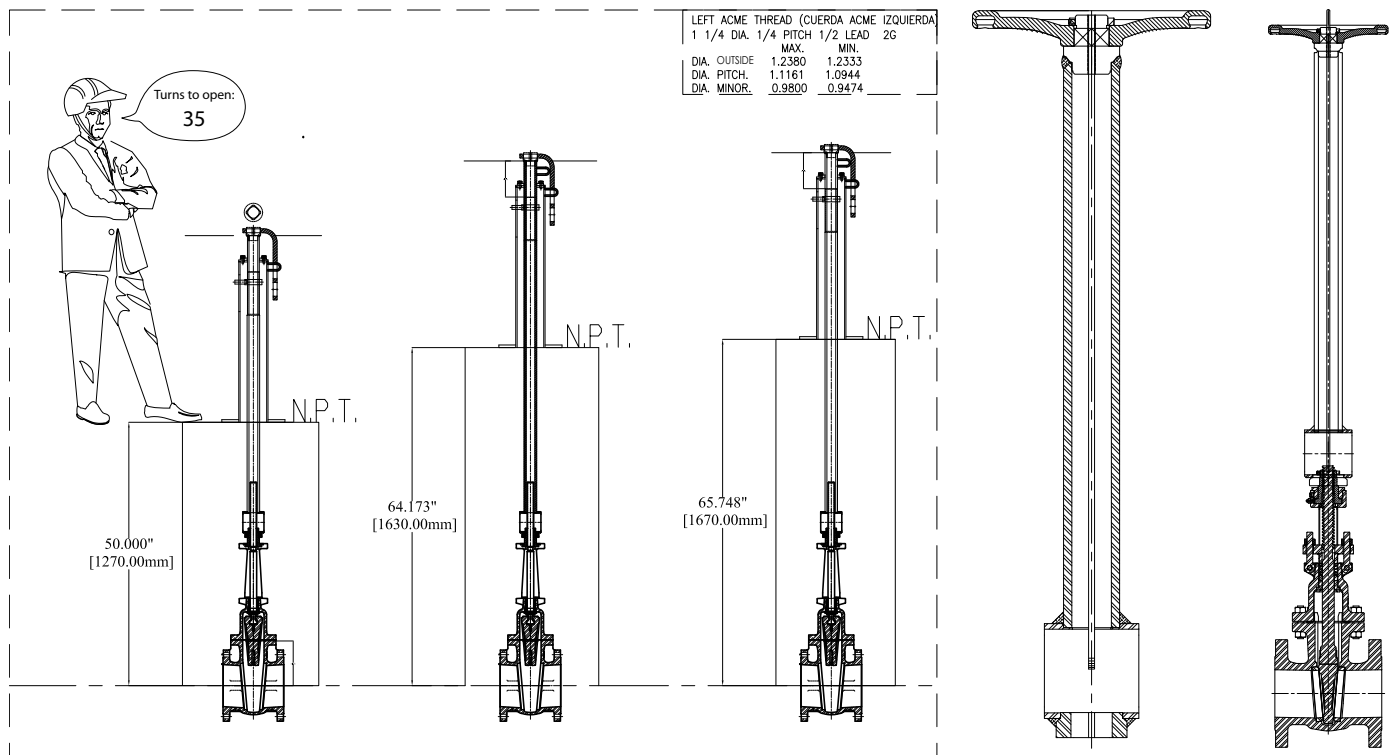

### Lever and Counter Weight

A lever and counter weight is used on a swing check valve to help control the valve opening under variable flow conditions to prevent disc flutter and also to assist/control the disc closing under a rapid flow reversal condition to prevent disc/seat damage. A spring can also be used with a lever to provide a more rapid closing as can a dash pot or snubber to soften the closing seat contact during a flow reversal.



# PRESSURE-TEMPERATURE RATINGS

## CAST STEEL ASTM A 216 GR WCB

°F Temperature °C		MAXIMUM ALLOWABLE NON-SHOCK WORKING PRESSURE IN PSIG BY CLASS						
		150	300	400	600	900	1500	2500
-20 to 100	-29 to 38	285	740	990	1,480	2,220	3,705	6,170
200	93	260	675	900	1,350	2,025	3,375	5,625
300	149	230	655	875	1,315	1,970	3,280	5,470
400	204	200	635	845	1,270	1,900	3,170	5,280
500	260	170	600	800	1,200	1,795	2,995	4,990
600	316	140	550	730	1,095	1,640	2,735	4,560
650	343	125	535	715	1,075	1,610	2,685	4,475
700	371	110	535	710	1,065	1,600	2,665	4,440
750	399	95	505	670	1,010	1,510	2,520	4,200
800	427	80	410	550	825	1,235	2,060	3,430
850	454	65	270	355	535	805	1,340	2,230
900	482	50	170	230	345	515	860	1,430
950	510	35	105	140	205	310	515	860
1000	538	20	50	70	105	155	260	430

(\*) For welding ends valves only. Flanged ends ratings terminate at 1000°F (538°C).

## CAST STEEL ASTM A 352 GR LCB

°F Temperature °C		MAXIMUM ALLOWABLE NON-SHOCK WORKING PRESSURE IN PSIG BY CLASS						
		150	300	400	600	900	1500	2500
-20 to 100	-29 to 38	265	695	925	1,390	2,085	3,470	5,785
200	93	250	655	875	1,315	1,970	3,280	5,470
300	149	230	640	850	1,275	1,915	3,190	5,315
400	204	200	620	825	1,235	1,850	3,085	5,145
500	260	170	585	775	1,165	1,745	2,910	4,850
600	316	140	535	710	1,065	1,600	2,665	4,440
650	343	125	525	695	1,045	1,570	2,615	4,355
700	371	110	520	690	1,035	1,555	2,590	4,320
750	399	95	475	630	945	1,420	2,365	3,945
800	427	80	390	520	780	1,175	1,955	3,260
850	454	65	270	355	535	805	1,340	2,230
900	482	50	170	230	345	515	860	1,430
950	510	35	105	140	205	310	515	860

(\*) For welding ends valves only. Flanged ends ratings terminate at 1000°F (538°C).

# PRESSURE-TEMPERATURE RATINGS

## CAST STEEL ASTM A 217 GR C5

°F Temperature °C		MAXIMUM ALLOWABLE NON-SHOCK WORKING PRESSURE IN PSIG BY CLASS						
		150	300	400	600	900	1500	2500
-20 to 100	-29 to 38	290	750	1,000	1,500	2,250	3,750	6,250
200	93	260	745	995	1,490	2,235	3,725	6,205
300	149	230	715	955	1,430	2,150	3,580	5,965
400	204	200	705	940	1,410	2,115	3,530	5,880
500	260	170	665	885	1,330	1,995	3,325	5,540
600	316	140	605	805	1,210	1,815	3,025	5,040
650	343	125	590	785	1,175	1,765	2,940	4,905
700	371	110	570	755	1,135	1,705	2,840	4,730
750	399	95	530	705	1,055	1,585	2,640	4,400
800	427	80	510	675	1015	1,525	2,540	4,230
850	454	65	485	645	965	1450	2,415	4,030
900	482	50	370	495	740	1110	1850	3,085
950	510	35	275	365	550	825	1370	2285
1000	538	20	200	365	400	595	995	1655
1050	566	20 (*)	145	190	290	430	720	1200
1100	593	20 (*)	100	135	200	300	495	830
1150	621	20 (*)	60	80	125	185	310	515
1200	649	15 (*)	35	45	70	105	170	285

(\*) For welding ends valves only. Flanged ends ratings terminate at 1000°F (538°C).

## CAST STEEL ASTM A 217 GR C12

°F Temperature °C		MAXIMUM ALLOWABLE NON-SHOCK WORKING PRESSURE IN PSIG BY CLASS						
		150	300	400	600	900	1500	2500
-20 to 100	-29 to 38	290	750	1,000	1,500	2,250	3,750	6,250
200	93	260	750	1,000	1,500	2,250	3,750	6,250
300	149	230	730	970	1,455	2,185	3,640	6,070
300	204	200	705	940	1,410	2,115	3,530	5,880
500	260	170	665	885	1,330	1,995	3,325	5,540
600	316	140	605	805	1,210	1,815	3,025	5,040
650	343	125	590	785	1,175	1,765	2,940	4,905
700	371	110	570	755	1,135	1,705	2,840	4,730
700	399	95	530	710	1,065	1,595	2,660	4,430
800	427	80	510	675	1015	1,525	2,540	4,230
850	454	65	485	650	975	1460	2,435	4,060
900	482	50	450	600	900	1350	2245	3,745
950	510	35	375	505	755	1130	1885	3145
1000	538	20	255	340	505	760	1270	2115
1050	566	20 (*)	170	230	345	515	855	1430
1100	593	20 (*)	115	150	225	340	565	945
1150	621	20 (*)	75	100	150	225	375	630
1200	649	20 (*)	50	70	105	155	255	430

(\*) For welding ends valves only. Flanged ends ratings terminate at 1000°F (538°C).

# PRESSURE-TEMPERATURE RATINGS

## CAST STEEL ASTM A 351 GR CF8

°F Temperature °C		MAXIMUM ALLOWABLE NON-SHOCK WORKING PRESSURE IN PSIG BY CLASS						
		150	300	400	600	900	1500	2500
-20 to 100	-29 to 38	275	720	960	1440	2160	3600	6,000
200	93	230	600	800	1200	1800	3000	5,000
300	149	205	540	720	1080	1620	2700	4,500
400	204	190	495	660	995	1490	2485	4,140
500	260	170	465	620	930	1395	2330	3,880
600	316	140	435	580	875	1310	2185	3,640
650	343	125	430	575	860	1290	2150	3,580
700	371	110	425	565	850	1275	2125	3,540
750	399	95	415	555	830	1245	2075	3,460
800	427	80	405	540	805	1210	2015	3,360
850	454	65	395	530	790	1190	1980	3,300
900	482	50	390	520	780	1165	1945	3,240
950	510	35	380	510	765	1145	1910	3,180
1000	538	20	320	430	640	965	1605	2,675
1050	566	20(*)	310	410	615	925	1545	2,570
1100	593	20(*)	255	345	515	770	1285	2,145
1150	621	20(*)	200	265	400	595	995	1,655
1200	649	20(*)	155	205	310	465	770	1,285
1250	677	20(*)	115	150	225	340	565	945
1300	704	20(*)	85	115	170	255	430	715
1350	732	20(*)	60	80	125	185	310	515
1400	760	20(*)	50	65	95	145	240	400
1450	788	15(*)	35	45	70	105	170	285
1500	816	10(*)	25	35	55	80	135	230

(\*) For welding ends valves only. Flanged ends ratings terminate at 1000°F (538°C).

## CAST STEEL ASTM A 351 GR CF8 M

°F Temperature °C		MAXIMUM ALLOWABLE NON-SHOCK WORKING PRESSURE IN PSIG BY CLASS						
		150	300	400	600	900	1500	2500
-20 to 100	-29 to 38	275	720	960	1440	2160	3600	6,000
200	93	230	600	800	1200	1800	3000	5,000
300	149	205	540	720	1080	1620	2700	4,500
400	204	190	495	660	995	1490	2485	4,140
500	260	170	465	620	930	1395	2330	3,880
600	316	140	435	580	875	1310	2185	3,640
650	343	125	430	575	860	1290	2150	3,580
700	371	110	425	565	850	1275	2125	3,540
750	399	95	415	555	830	1245	2075	3,460
800	427	80	405	540	805	1210	2015	3,360
850	454	65	395	530	790	1190	1980	3,300
900	482	50	390	520	780	1165	1945	3,240
950	510	35	380	510	765	1145	1910	3,180
1000	538	20	320	430	640	965	1605	2,675
1050	566	20(*)	310	410	615	925	1545	2,570
1100	593	20(*)	255	345	515	770	1285	2,145
1150	621	20(*)	200	265	400	595	995	1,655
1200	649	20(*)	155	205	310	465	770	1,285
1250	677	20(*)	115	150	225	340	565	945
1300	704	20(*)	85	115	170	255	430	715
1350	732	20(*)	60	80	125	185	310	515
1400	760	20(*)	50	65	95	145	240	400
1450	788	15(*)	35	45	70	105	170	285
1500	816	10(*)	25	35	55	80	135	230

(\*) For welding ends valves only. Flanged ends ratings terminate at 1000°F (538°C).

# PRESSURE-TEMPERATURE RATINGS

## CAST STEEL ASTM A 217 GR WC6

°F Temperature °C		MAXIMUM ALLOWABLE NON-SHOCK WORKING PRESSURE IN PSIG BY CLASS						
		150	300	400	600	900	1500	2500
-20 to 100	-29 to 38	290	750	1,500	2,250	3,750	6,250	11,250
200	93	260	750	1,500	2,250	3,750	6,250	11,250
300	149	230	720	1,445	2,165	3,610	6,015	10,830
400	204	200	695	1,385	2,080	3,465	5,775	10,400
500	260	170	665	1,330	1,995	3,325	5,540	9,965
600	316	140	605	1,210	1,815	3,025	5,040	9,070
650	343	125	590	1,175	1,765	2,940	4,905	8,825
700	371	110	570	1,135	1,705	2,840	4,730	8,515
750	399	95	530	1,065	1,595	2,660	4,430	7,970
800	427	80	510	1,015	1,525	2,540	4,230	7,610
850	454	65	485	975	1,460	2,435	4,060	7,305
900	482	50	450	900	1,350	2,245	3,745	6,740
950	510	35	320	640	955	1,595	2,655	4,785
1,000	538	20	215	430	650	1,080	1,800	3,240
1,050	566	20(a)	145	290	430	720	1,200	2,160
1,100	593	20(a)	95	190	290	480	800	1,440
1,150	621	20(a)	65	130	195	325	545	975
1,200	649	15(a)	40	80	125	205	345	615

(a) Flanged-end valve ratings terminat at 1,000°F.

## CAST STEEL ASTM A 217 GR WC9

°F Temperature °C		MAXIMUM ALLOWABLE NON-SHOCK WORKING PRESSURE IN PSIG BY CLASS						
		150	300	600	900	1500	2500	4500
-20 to 100	-29 to 38	290	750	1,500	2,250	3,750	6,250	11,250
200	93	260	750	1,500	2,250	3,750	6,250	11,250
300	149	230	730	1,455	2,185	3,640	6,070	10,925
400	204	200	705	1,410	2,115	3,530	5,880	10,585
500	260	170	665	1,330	1,995	3,325	5,540	9,965
600	316	140	605	1,210	1,815	3,025	5,040	9,070
650	343	125	590	1,175	1,765	2,940	4,905	8,825
700	371	110	570	1,135	1,705	2,840	4,730	8,515
750	399	95	530	1,065	1,595	2,660	4,430	7,970
800	427	80	510	1,015	1,525	2,540	4,230	7,610
850	454	65	485	975	1,460	2,435	4,060	7,305
900	482	50	450	900	1,350	2,245	3,745	6,740
950	510	35	385	755	1,160	1,930	3,220	5,795
1,000	538	20	265	535	800	1,335	2,230	4,010
1,050	566	20(a)	175	350	525	875	1,455	2,625
1,100	593	20(a)	110	220	330	550	915	1,645
1,150	621	20(a)	70	135	205	345	570	1,030
1,200	649	15(a)	40	80	125	205	345	615

(a) Flanged-end valve ratings terminat at 1,000°F.

## DESIGN BASIS

All of **WALWORTH**'s Valve Designs, when applicable, follow one or more of the following standards.

- API** American Petroleum Institute.  
**6D** Steel gate, ball and plug valves for pipeline service.  
**6FA** Specification for Fire Test for Valves.
- ASME/ANSI** American National Standard Institute:  
**B2.1** Pipe threads.  
**B16.5** Steel pipe Flanges and flanged fittings.  
**B16.10** Length of ferrous flanged and welding end valves.  
**B16.25** Butt-welding ends.  
**B18.2** Square and hexagon bolts and nuts.  
**B16.47** Large Diameter Steel Flanges
- ASTM** American Society for Testing and Materials:  
**A-193** Alloy steel bolting material for high temperature service.  
**A-194** Carbon and alloy steel nuts for high pressure and high temperature service, class2.  
**A-216** Standard specification for steel castings, Carbon, Suitable for Fusion Welding, for High-temperature Service.
- MSS** Manufactures Standardization Society of the Valve and Fittings:  
**SP-25** Standard marking system for valves, fittings, flanges and unions.  
**SP-44** Steel pipe line flanges.  
**SP-47** Limiting dimensions of raised face flange gaskets.  
**SP-61** Pressure testing of steel valves.
- ASME** American Society of Mechanical Engineers:  
**Section II** Part A, B and C.  
**Section V** Non-destructive Tests.  
**Section VIII** Boiler and Pressure Vessel Code for Unfired Pressure Vessels, Divisions 1 and 2.  
**Section IX** Welding Qualifications.





# HOW TO ORDER

WALWORTH valves are designed by a catalog figure number which describe their main characteristics. The valve identification system shown herein is intended to assist our Customers to specify the valve required and avoid mistakes during manufacturing.

10"-5202-RF-UT-WCB-GO-NACEMR01-75



SIZE (INCH)	TYPE OF VALVE & PRESSURE CLASS	ENDS	TRIM ARRANGEMENTS	BASE MATERIAL ASTM
2"	5202= GATE 150#	RF= RAISED FACE	18-8= API No. 2	<b>CARBON STEELS:</b>
2 1/2"	5206= GATE 300#	RTJ= RING TYPE JOINT	310= API No. 3	A216-WCB (C-Si)
3"	5232= GATE 600#	WE=BUTTWELD	HF= API No. 5	A216-WCC (C-Si)
4"	5247= GATE 900#		AAA= API No. 6	LOW ALLOY STEELS:
5"	5262= GATE 1500#		UT= API No. 8	A217-WC1 (C-1/2Mo)
6"	5275= GLOBE 150#		A= API No. 9	A217-WC5 (Cr-Mo)
8"	5281= GLOBE 300#		18-8smo= API No. 10	A217-WC6 (1 1/4%Cr-1/2Mo)
10"	5295= GLOBE 600#		AHF= API No. 11	ASTM A217-WC9(2 1/4 % Cr-1%Mo)
12"	5301= GLOBE 900#		3HF= API No. 12	ASTM A217-C5(5% Cr-1/2Mo)
14"	5308= GLOBE 1500#		A20= API No. 13	ASTM A217-C12(9%Cr-1%Mo)
16"	5341= CHECK 150#		A20H= API No. 14	ASTM A217-C12-A(9%Cr-1%Mo-V-N)
18"	5344= CHECK 300#		NUC= 410 + NUCALLOY	<b>LOW CARBON AUSTENITIC STAINLESS STEELS:</b>
20"	5350= CHECK 600#		4HF= 304+304+ST6	ASTM A351-CF3(18%Cr-8%Ni-0.03%C)
22"	5353= CHECK 900#		4HF+HF= 304+ST6+ST6	ASTM A351-CF3M(18%Cr-12%Ni-2%Mo-0.03%C)
24"	5356= CHECK 1500#		304L= 304L+304L+304L	ASTM A351-CG3M(18%Cr-12%Ni-3%Mo-0.03%C)
28"			1HF= 316+ST21+ST21	<b>AUSTENITIC STAINLESS STEELS:</b>
30"			3HF+HF= 316+ST6+ST6	ASTM A351-CF8(18%Cr-8%Ni-0.08%C)
36"			3TC= 316/TC+TC+ST6 NOTE: TC= Tungsten Carbide.	ASTM A351-CF8M(18%Cr-12%Ni-2%Mo-0.08%C)
42"			316L= 316+316+316	ASTM A351-CF10(18%Cr-8%Ni-0.08%C)
48"			3LHF= 316L+316L+ST6	ASTM A351-CG8M(19%Cr-10%Ni-3%Mo-0.08%C)
54"			3HFL= 316L+ST6+ST6	ASTM A351-CF8C(18%Cr-10%Ni-Cb-0.08%C)
60"			21HF= 317+ST6+ST6	ASTM A351-CT15C(19%Cr-32%Ni-0.05A 0.15%C)
72"			317= 317+317+317	<b>SUPER AUSTENITIC STAINLESS STEELS:</b>
			317H= 317+317+ST6	ASTM A351-CK20(25%Cr-20%Ni-0.04A 0.2%C)
			31L= 317L+317L+317L	ASTM A351-CN7M(28%Ni-19%Cr-Cu-Mo- 0.7%C)
			317LS= 317L+317L+ST6	ASTM A351-CN3M(21%Cr-8%Ni-6.5%Mo)
			2HF= 321+321+ST6	ASTM A351-CN3MN(24%Ni-21%Cr-6%Mo-Cu-N-0.03%C)
			321F= 321+ST6+ST6	ASTM A351-CD4MCu(25.5%Cr-5.5%Ni-2%Mo)
			321= 321+321+321	ASTM A351-CN2MCuN(.02C;19-23Cr;23-28Ni;4-5Mo;1-2Cu)
			347HF= 347+ ST6+ST6	<b>LOW TEMPERATURE SERVICE CARBON STEELS:</b>
			347= 347+347+347	ASTM A352-LCB(0.03%C-0.6%Si-1%Mn)
			347= 347+347+ST6	ASTM A352-LCC(0.025%C-0.6%Si-1%Mn)
			254HF= 31254+ST6+ST6	<b>LOW TEMPERATURE SERVICE LOW ALLOYS STEELS:</b>
			51H= 31803+ST6+ST6	ASTM A352-LC2(0.025%C-2.5%Ni-0.65%Mn)
			31803H= 31803+31803+ST6	ASTM A352-LC3(0.15%C-3.5%Ni-0.65%Mn)
			T9= 17-4pH+TRIBALLOY 900+ TRIBALLOY 900	<b>MARTENSITIC STAINLESS STEELS:</b>
			HC= Hc-276+Hc-276+Hc-276	ASTM A487-CA6NM(12.75%Cr-4%Ni-0.7%Mo)
			HCH= Hc-276+Hc-276+ST6	ASTM A487-CA15(12.75%Cr-1%Ni-1%Mo)
			UOP= MONELK500+MONEL 400+MONEL 400	<b>NICKEL ALLOYS:</b>
			625= INCONEL 625+INCONEL 625+INCONEL 625	ASTM A494-M30C(67%Ni-30%Cu)
			625HF= INCONEL 625+ST6+ST6	ASTM A494-M35-1(67%Ni-30%Cu)
			8367HF+HF= AL6XN+ST6+ST6	ASTM A494-CZ100(95%Ni)
			810T= INCOLOY 800H+INCOLOY 800H+INCOLOY800H	ASTM A494-CY40(75%Ni-15%Cr-8%Fe)
			825= INCOLOY 825+INCOLOY825+INCOLOY 825	ASTM A494-CW2M(61%Ni-16%Mo-16%Cr)
			23HF= INCOLOY 825+ST6+ST6	ASTM A494-N12MV(62%Ni-28%Mo-5%Fe)
			HB= HASTELLOY B2+HASTELLOB2+HASTELLOY B2	ASTM A494-CW12MW(56%Ni-18%Mo-17%Cr-6%Fe)
			HB= HASTELLOY B2+HASTELLOB2+HASTELLOY B2	ASTM A494-CW6M(56%Ni-19%Mo-18%Cr-2%Fe)
			<b>NOTE: ADDITIONAL BASE MATERIALS &amp; TRIMS ARE AVAILABLE UPON REQUEST.</b>	ASTM A494-CU5MCuC(42%Ni-21.5%Cr-3%Mo-2.3%Cu)
				ASTM A494-N7M(65%Ni-28%Mo-2%Fe)
				ASTM A494-CW6MC(60%Ni-22%Cr-9%Mo-3.5%Cb)
				<b>DUPLEX STAINLESS STEELS:</b>
				ASTM A351-CD7MCuN(20.5%Cr-29%Ni-2.5%Mo)
				ASTM A890 1A; CD4MCu(25.5%Cr-5.5%Ni-2%Mo)
				ASTM A890 2A; CE8MN(24%Cr-9.5%Ni-4%Mo)
				ASTM A890 3A; CD6MN(25.5%Cr-5%Ni-2.25%Mo)
				ASTM A890 3A; CD3MN(22%Cr-5%Ni-3%Mo-N)

SUPPLEMENTARY REQUIREMENTS
GO= Gear operator.
CW=Chainwheel operator.
BS=Bare stem prepared for actuator.
MOV= Motor operated valve.
POV= Pneumatic operated valve.
LD= Locking device.
NACEMR-01-75.
NACEMR-01-03
SP= Special Paint.
SG= Special gasket.
SPK= Special packing.
VOC= Certification of volatile organic compounds.
BP=By-Pass
LL=Live Load Packing
LR=Lantern Ring
LCW=Lever & Counter Weight
SE=Stem extensions
FS=Floor atands
XX= Additional requirements.

# THE WALWORTH COMPANY GENERAL TERMS AND CONDITIONS

**ACCEPTANCE:** All quotations are for acceptance within 30 days from date of quotation unless extended in writing. In the event a purchase order is placed after this period of time, The Walworth Company reserves the right to requote base prices of all valves offered. All orders and contracts are subject to credit approval and acceptance by the Walworth Company.

**FREIGHT:** When prices are f.o.b. point of shipment –no freight allowance, we will attempt to route shipments in the method which will result in the lowest cost unless otherwise instructed. All shipments will be freight charges collect except when stipulated on the purchase order, in which case you will be invoiced for all transportation charges. Delivery of material to a common carrier shall be considered to be delivery to Buyer and shall be at Buyer's risk thereafter. Claims of loss of or damage to material in transit shall be filed by the Buyer directly with the carrier.

**PRICES:** There will be added to all prices quoted sales, use, occupation or any other excise or similar tax which Seller may be required to pay or collect on or in connection with the sale. Seller shall be established by Federal, State or other government regulation with respect to the product(s) covered by the order which shall be lower than the price(s) specified in the order.

**ESCALATION TERMS:** Prices shown in this price schedule reflect the costs in effect at the time of publication. These prices will remain firm on all products with a quoted delivery of twenty-six (26) weeks or less. On products which have a scheduled delivery of more than twenty-six (26) weeks, the goods will be invoiced based on the applicable price sheet in effect at the time of shipment. In no event will the invoiced price be less than the price originally quoted.

**PURCHASED COMPONENTS:** (i.e. motors, gearing, etc.) Prices are quoted on supplier price in effect at time of quotation. Actual invoice Price will be adjusted in accordance with the supplier's escalation policy.

**DEFERRED SHIPMENTS:** If for any reason the customer desires to delay shipments more than 30 days after manufacturing is complete or to place a hold or stop to the order during the manufacturing cycle, The Walworth Company reserves the right to consider the order cancelled and to invoke cancellation charges per the schedule below.

**CANCELLATION:** After order acceptance by Walworth, items or completed orders may be cancelled and buyer will be charged for work performed, based on the following schedule:

- Five (5%) percent of prices of stock items.
- Ten (10%) percent of price of stock items ordered in quantities which exceed normal inventory levels.
- Five (5%) percent of prices prior to drawing submittal on made-to-order items.
- 15% after drawing approval, but prior to the start of castings.
- 30% to 50% during casting cycle, depending on the state of completion.
- 55% to 75% during machining and assembly operations, depending on the state of completion.
- 100% after final assembly and test.

**REMITTANCES:** Remittances must be made to the address indicated on the invoice.

**CREDIT TERMS:** As quoted. Invoices on balances overdue will be subject to a service charge of 11/2 % per month on such indebtedness.

**DELIVERIES:** Shipments and deliveries shall at all times be subject to the approval of Seller's Credit Department. If the Buyer shall fail to make any payments according to the terms of the contract, Seller may, in addition to and not in limitation of its other rights and remedies, at its option, cancel all or any part of Buyer's incomplete contracts with Seller or may defer shipments of deliveries under Buyer's contracts with Seller except upon receipt of satisfactory security or for cash shipment.

All schedule of shipments are estimated as closely as possible and Seller will use its best efforts to ship within the time scheduled, but does not guarantee to do so. Schedules commence with the date Seller receives authorization to proceed with order, subject to the provisions of the next sentence. The order will not be released for manufacture until complete specifications and approved drawings (if drawing approval is required) are received at the plant of manufacture and the estimated schedule of shipment will commence with the date of such receipt.

Seller shall not be liable for any direct, indirect or consequential damage or loss caused by any delay in delivery, regardless of the cause of delay.

Without limiting the generality of the foregoing, Seller assumes no responsibility for delays in delivery resulting from fire, flood, accidents, riots, strikes, transportation delays, labor or material shortages, existing or future laws, acts of any governmental authority, or any other cause beyond Seller's control. Items offered from stock are subject to prior sale.

**INSPECTION:** Final inspection and acceptance of products must be made at the plant of manufacture, unless otherwise provided in the order and/ or in agreed upon specifications. Prices do not include charges for special tests or inspections performed at the request of the Buyer, unless called for in the order and/or in agreed upon specifications.

**RETURNS:** Permission in writing and return tagging instructions must be obtained from Seller before any goods returned for credit or adjustment will be acceptance. Where returned goods are accepted, a minimum charge of 25% of the invoice price will be made, plus freight from both directions and costs of reconditioning the material for resale as new.

**WARRANTY:** Seller will replace without charge or refund the purchase price of products manufactured by Seller which prove to be defective in the material or workmanship, provided in each case that the product is properly installed and is used in the service for which Seller recommends it and that written claim, specifying the alleged defect, is presented to Seller shall in no event be responsible for (a) claims for labor, expenses or other damages occasioned by defective products or (b) for consequences or secondary damages. **THE WARRANTY STATED IN THIS PARAGRAPH IS IN LIEU OF ALL OTHER WARRANTIES, EITHER EXPRESSED OR IMPLIED. WITH RESPECT TO WARRANTIES THIS PARAGRAPH STATES BUYER'S EXCLUSIVE REMEDY AND SELLER'S EXCLUSIVE LIABILITY.**

**DESIGN, ETC:** Seller reserves the right to change design, materials or specifications without notice. There will be a charge for modifying an order after it has been entered when such change or modification results in additional engineering or clerical work for either The Walworth Company or our suppliers.

**MINIMUM CHARGE:** Orders totaling less than \$100.00 net will be billed at a minimum charge of \$100.00. Repair parts will be billed at a minimum charge of \$50.00.

**NOTE:** We reserve the right to correct obvious clerical errors in quotations, invoices, and other contracts.





# **WALWORTH**®

*Since 1842*



Visit our website for more detail information  
[www.walworthmx.com](http://www.walworthmx.com)

## **MEXICO**

Industrial de Válvulas, S.A. de C.V.  
Av. de la Industria Lote 16  
Frac. Industrial El Trébol, C.P. 54600  
Tepetzotlán, Estado de México

Phone: (52 55) 5899 1700  
Fax: (52 55) 5876 0156

e-mail: [info@walworth.com.mx](mailto:info@walworth.com.mx)

## **USA**

TWC The Valve Company  
Authorized Distributor  
13641 Dublin Court, Stafford, Texas 77477

Phone: (713) 996 9696  
Toll Free: (1 800) 697 1842  
Fax: (713) 996 9669

e-mail: [info@twcousa.com](mailto:info@twcousa.com)  
[www.twcousa.com](http://www.twcousa.com)