

## Resilient Seated Butterfly Valves: 2"-20"

Wafer/Lug High Pressure–Bonded Seats

500  
SERIES  
522

Ultraflo is proud to offer a line of economical, high pressure butterfly valves that meet today's industrial process requirements.

### FEATURES

- 500 Series Wafer and 522 Series Lug style cast iron bodies are offered. Lug bodies are drilled and tapped to meet ANSI Class 125/150 flanges.
- Disc is spherically machined and hand polished to provide a bubble tight shut-off, with minimum torque and extended life.
- Stem to disc connection features a taper pin design for high pressure requirements.
- Unique "tongue and groove" seat design is designed to seal with slip-on or weld-neck flanges. Seat totally encases the valve interior to isolate the body from the line media. In addition, all 500 Series seats are bonded for increased pressure rating.
- Molded seat O-ring provides seal between valve and pipe flanges. Flange gaskets should not be used with this valve.
- Primary and secondary seals are interference fits between seat and disc hub, and stem and seat stem hole respectively.



- Corrosion resistant, heavy duty acetal bushing absorbs side thrusts.
- Stem packing gland is a self-adjusting double "U" cup design and gives positive sealing in both directions, preventing external substances from entering the stem bore.

- Mounting flange meets ISO 5211 and allows direct mounting of Ultraflo manual operators and power actuators.

**ultraflo**®

# 500/522 SERIES

## Dimensions

Valve Size		A	B	C	D	E	F	G	H	Q	R	S	T	U	Lug Data		
ins	mm														BC	Holes	Tap
2	50	4.0	.375	.563	1.25	5.50	3.69	2.00	1.62	1.32	3.25	.44	2.76	.375	4.75	4	5/8-11
2 1/2	65	4.0	.375	.563	1.25	6.00	4.19	2.50	1.75	1.91	3.25	.44	2.76	.375	5.50	4	5/8-11
3	75	4.0	.375	.563	1.25	6.30	4.88	3.00	1.75	2.55	3.25	.44	2.76	.375	6.00	4	5/8-11
4	100	4.0	.438	.625	1.25	7.00	6.06	4.00	2.00	3.57	3.25	.44	2.76	.375	7.50	8	5/8-11
5	125	4.0	.500	.750	1.25	7.50	7.12	5.00	2.12	4.63	3.25	.44	2.76	.375	8.50	8	3/4-10
6	150	4.0	.500	.750	1.25	8.00	8.12	5.75	2.12	5.45	3.25	.44	2.76	.375	9.50	8	3/4-10
8	200	6.0	.625	.875	1.25	9.50	10.50	7.75	2.50	7.45	5.00	.56	4.02	.438	11.75	8	3/4-10

Valve Size		A	C	D	E	F	G	H	Q	Key Way	R	S	T	U	Lug Data		
ins	mm														BC	Holes	Tap
10	250	6.0	1.125	2.0	10.75	12.75	9.75	2.50	9.53	.25 x .25	5.00	.56	4.02	.438	14.25	12	7/8-9
12	300	6.0	1.125	2.0	12.25	14.88	11.75	3.00	11.47	.25 x .25	5.00	.56	4.02	.438	17.00	12	7/8-9
14	350	5.9	1.38	2.0	13.62	16.94	13.25	3.00	13.04	.39 x .39	4.92	.56	—	—	18.75	12	1-8
16	400	5.9	1.38	2.0	14.75	19.06	15.25	4.00	14.85	.39 x .39	4.92	.56	—	—	21.25	16	1-8
18	450	8.3	1.97	2.5	16.00	21.12	17.25	4.25	16.85	.39 x .47	6.50	.81	—	—	22.75	16	1 1/8-7
20	500	8.3	1.97	2.5	17.25	23.25	19.25	5.00	18.73	.39 x .47	6.50	.81	—	—	25.00	20	1 1/8-7

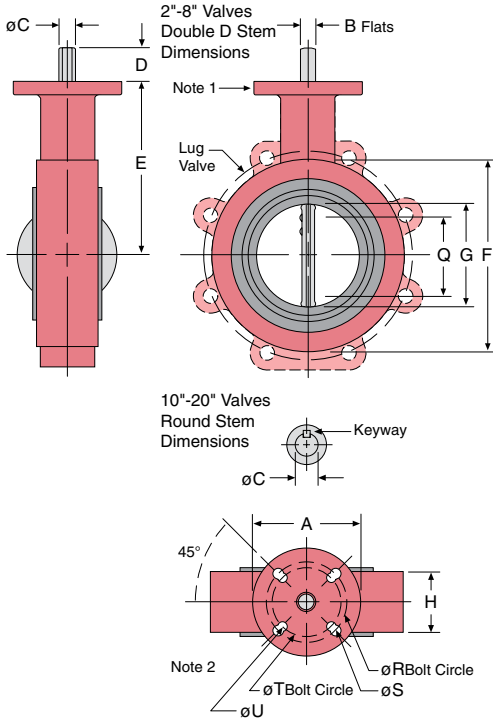

## C<sub>v</sub> Values—Valve Sizing Coefficient

Valve Size		Disc Position (degrees)								
ins	mm	90°	80°	70°	60°	50°	40°	30°	20°	10°
2	50	144	114	84	61	43	27	16	7	1
2 1/2	65	282	223	163	107	67	43	24	11	1.5
3	80	461	364	267	154	96	61	35	15	2
4	100	841	701	496	274	171	109	62	27	3
5	125	1376	1146	775	428	268	170	98	43	5
6	150	1850	1542	1025	567	354	225	129	56	6
8	200	3316	2842	1862	1081	680	421	241	102	12
10	250	5430	4525	2948	1710	1076	667	382	162	19
12	300	8077	6731	4393	2563	1594	1005	555	235	27
14	350	10538	8874	5939	3384	2149	1320	756	299	34
16	400	13966	11761	7867	4483	2847	1749	1001	397	45
18	450	17214	14496	10065	5736	3643	2237	1281	507	58
20	500	22339	18812	12535	7144	4536	2786	1595	632	72

C<sub>v</sub> is defined as the volume of water in U.S.G.P.M. that will flow through a given restriction or valve opening with a pressure drop of one (1) p.s.i. at room temperature. Recommended control angles are between 25°–70° open. Preferred angle for control valve sizing is 60°–65° open.

### Pressure Ratings

For bidirectional and dead end service, bubble-tight shut off, disc in closed position, 500 & 522 Series: 2"-20" 250 psi Tested to 110% of pressure rating.

**Velocity Limits** For On/Off Services:  
Fluids – 30 ft/sec Gases – 175 ft/sec

### Temperature Range of Seats

Aerospace-Bonded Food Grade  
EPDM: -40°F to 250°F  
Buna N: 0°F to 212°F

### Materials of Construction

- Bodies:** Polyester coated Cast Iron, A126 Class B
- Seats:** Food Grade EPDM & Buna N
- Discs:**
  - 316 Stainless Steel, A351 Gr. CF8M
  - Aluminum Bronze, B148-953
  - Ductile Iron (Phosphate Coated), A536 Gr. 65-45-12
- Stems:** Type 416 Stainless Steel, A582 Cond.T
- Taper Pins:** 17-4 PH, A564 Type 630, HT 1075

Please refer to Ultraflo's website periodically to ensure this brochure is the latest version.

The data represented in this brochure is for general information only. Manufacturer is not responsible for acceptability of these products in relation to system requirements. Consult your Ultraflo representative for specific performance data and proper materials selection for your particular application.

© 2009 Ultraflo Corporation. All rights reserved.  
L-4500\_EN\_S500-522-2009-08



**Ultraflo Corporation**  
A Subsidiary of Bray International, Inc.  
8 Trautman Industrial Drive  
Ste. Genevieve MO 63670  
800.950.1762 Fax 573.883.8882  
www.ultraflovalve.com