



Innovators in Flow Technology



Drum and Container Pumps

New!

with even more powerful
drum pump motor FEM 4070

FLUX Pumps: Perfection in Pumping

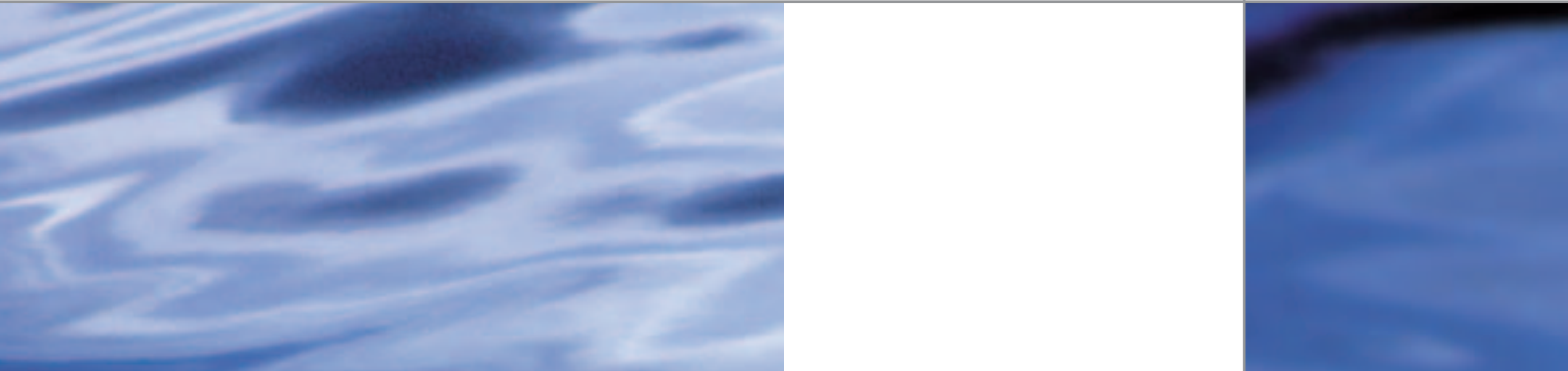

Do you want to transfer differing liquids quickly and economically?

Do you want to measure out varying quantities?

Do you want to ensure total safety for the operator or the environment when pumping hazardous products?

Do you want a pump which can cope even with peak loadings?

Barrel and Container Pumps are used in almost every sector of the processing and manufacturing industries.

Initially designed for decanting and transfer operations of differing liquids from barrels and containers, current production time scales are now requiring these pumps to be used on applications with extended run times and frequent stopping and starting.

Whenever liquids are pumped out of a drum or container, FLUX can supply a unit of unsurpassed quality: all FLUX pumps are available in different materials. You can choose between a pump with a mechanical seal or a sealless version. One of the unique features of both, the Polypropylene and the PVDF mechanical seal version, is the steel cored inner tube providing, through increased lateral stability, a longer service life. Both, mixed centrifugal and axial impellers are available to suit differing head and flow applications. And if you want to combine the pumping and mixing operation FLUX also have the pump you need.

Another feature is the FLUX quick assembly system. This allows for simple and speedy pump strip down.

Of course, FLUX pumps require a powerful and reliable drive motor. A wide range of electric or compressed air motors provides a matched power unit throughout the pump range – even in hazardous locations or when pumping highly flammable liquids. To complete the comprehensive FLUX program, a wide range of top class accessories is available – from protection against emission of noxious vapours through to the volumetric measurement of liquids.



For further information to our pre-configured drum-pump kits see page 34

Table of Contents



New! Compact! Safe!

The drum pump motor FEM 4070 with

- Variable speed
 - Overload protection
 - Ergonomically designed handle
 - Low noise level
 - Advanced flow rate
- and much more ...
see page 24



Which material goes best with which liquid	4
Design concepts of FLUX drum and container pumps	5 – 9
FLUX drum pumps (pump tube sets) in Stainless Steel (S), Aluminium Alloy (AL) and Hastelloy C (HC) in detail, together with performance charts	10 – 13
FLUX drum pumps (pump tube sets) in Polypropylene (PP) and Polyvinylidene fluoride (PVDF) in detail, together with performance charts	14 – 17
FLUX container pump (pump tube set) in Polypropylene (PP) in detail, together with performance chart	18
FLUX drum and container pumps for horizontal use FLUX quick action coupling	19
FLUX motor data in detail	20 – 27
Summary of FLUX motor – pump combination	28 – 29
Outline of FLUX drum and container pumps with accessories	30 – 31
Dimensions of FLUX drum pumps and drive motors	32 – 33
The great range of FLUX pumps	34 – 35

FLUX Drum and Container Pumps – which material goes best with which liquid

Stainless Steel 1.4571/316 Ti (S) up to 212 °F

Suitable for highly flammable liquids (up to temperatures of class T4) as well as for all neutral and non-flammable, thin liquids like solvents, organic acids, dilute anorganic acids and alkalis.

Certified for use in Zone 0*

Examples of suitable liquids: acetone, alcohol, ammonia, petrol, flammable solvents, nitrocellulose varnishes, perchlorethylene, trichlorethylene, toluene, potassic alkali, soda alkali, phosphoric acid (up to 60 %), sulphuric acid (up to 7,5 % and more than 96 %), fruit juices, milk, salad oil and all liquids listed for aluminium alloy.

Hastelloy C (HC) up to 248 °F

Specially designed for pumping alternatively highly flammable and chemically aggressive liquids.

Certified for use in Zone 0*

Examples of suitable liquids: hydrofluoric acid, aqua regia, oleum, hydrochloric acid (up to 30 %), sulphuric acid, various mixed acids and all liquids listed for aluminium alloy and Stainless Steel.

Aluminium alloy AlMg5 (AL) up to 212 °F

Suitable for neutral, hardly flammable liquids.

Examples of suitable liquids: drilling emulsion, diesel oil, fuel oil, hydraulic oil, non-flammable solvents, liquid soap, liquid wax, water.

Polypropylene (PP) up to 122 °F

Suitable for both, chemically aggressive and neutral liquids, together with hardly flammable liquids such as acids and alkalis.

Examples of suitable liquids: formic acid, ammonia, boric acid, chromic acid (up to 10 %), liquid fertilizers, acetic acid, photo developers, hydrofluoric acid (up to 70 %), fruit acids, potassic alkali, copper chloride, lactic acid, soda alkali, phosphoric acid, hydrochloric acid, sulphuric acid (up to 80 %), distilled water.

Polyvinylidene fluoride (PVDF) up to 212 °F

Suitable for both, chemically aggressive and neutral liquids, together with hardly flammable liquids such as acids and alkalis.

Examples of suitable liquids: hydrobromic acid, chromic acid, chloric acid, hydrofluoric acid, sodium hypochlorite, nitric acid (up to 75 %), sulphuric acid and all liquids listed for polypropylene (except soda alkali).

***Zone 0**



Area in which a hazardous and explosive atmosphere of gases, vapours or fogs exists permanently or for a long period of time. In general such conditions exist inside of drums or containers only.

The following pump models are tested and certified according to ATEX-Directive 94/9/EC, category 1/2, for transferring highly flammable liquids out of portable drums or containers in hazardous areas:

**F 424 S – EC Type examination certificate
PTB 00 ATEX 4108 X**

**F 425 S – EC Type examination certificate
PTB 99 ATEX 4001 X**

**F 426 S – EC Type examination certificate
PTB 00 ATEX 4109 X**

**F 430 S – EC Type examination certificate
PTB 00 ATEX 4110 X**

**F 430 HC – EC Type examination certificate
PTB 00 ATEX 4110 X**

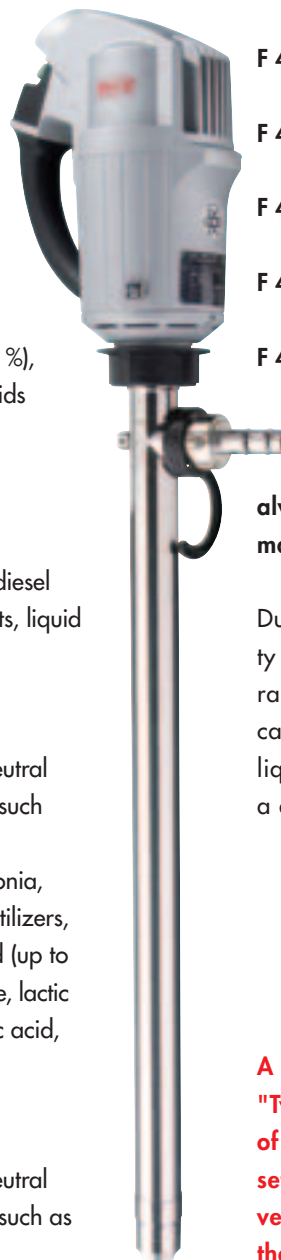

In selecting a pump model, please always check material of pump and material of seals for compatibility.

Due to the enormous variety and complexity of industrial chemicals, together with the range and variation of FLUX products, we can only list some of all the suitable liquids. But we would be glad to send you a detailed Resistance Chart.

A FLUX drum pump is always a "Two-Component-Team" consisting of a drive motor and a pump (tube set). Both component parts are universally interchangeable. For further details please see page 10 onwards.

In good contact with the liquids: The sealless FLUX Pump F 424



The liquids to be pumped are abrasive, but they do not leave any deposits. Dry running of the pump must not cause any problems. You are looking for a lightweight, general purpose pump in Stainless Steel, Polypropylene or Polyvinylidene fluoride.

The inner tube supports the pump shaft, which is lubricated by the liquid. The level of the liquid in the inner tube always corresponds to that in the drum or container.

Special advantages:

- Safe dry running of the pump
- No wearing of seals
- The liquid being pumped is not contaminated by the shaft lubricant
- Inner tube and helix shaped support bearings completely self-draining

Here a FLUX pump in sealless version is your pump.

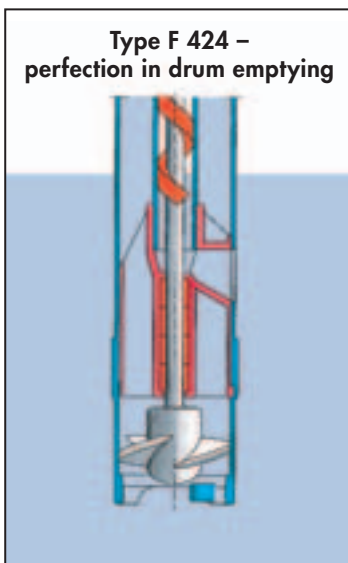

Flexible coupling between motor and pump

O-ring to seal between inner and outer tube (not in the liquid section)

Radial shaft seals to prevent liquid and/or vapours entering the coupling area

Non-metallic helix shaped shaft support bearing

Pressure relief ports

Bottom bearing assembly which centers the shaft within the inner tube

Impeller in ETFE

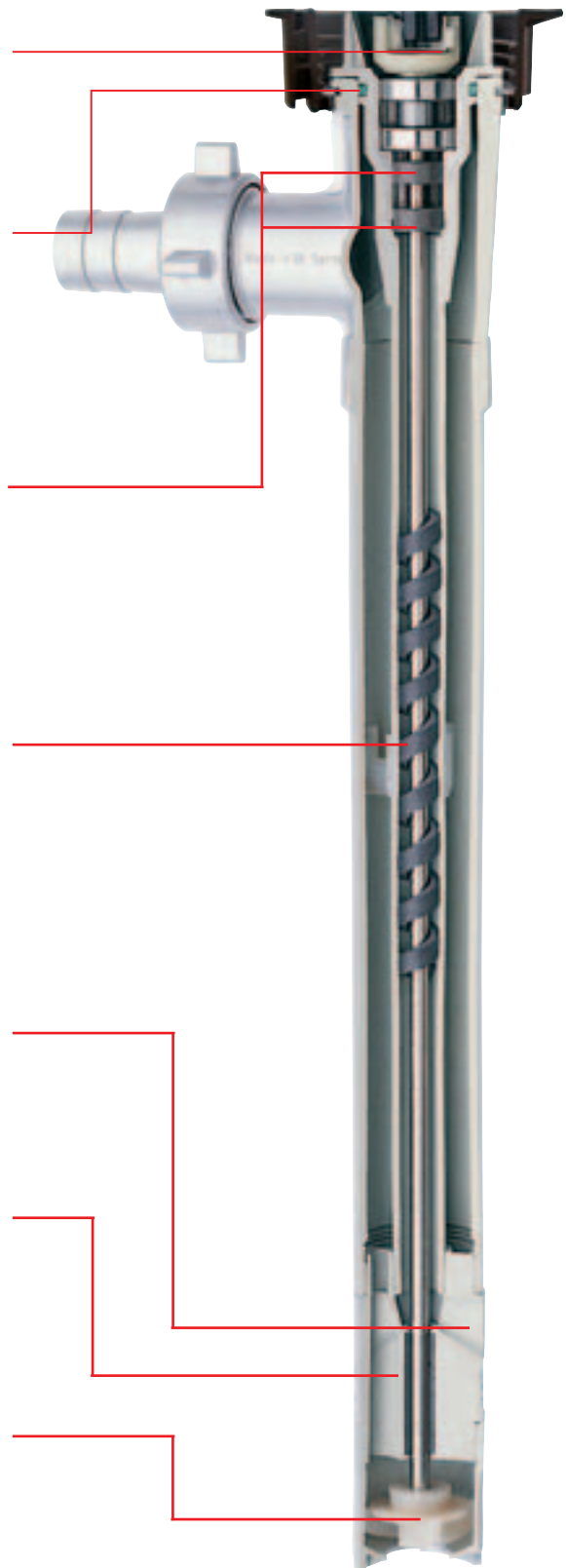

Note: All FLUX drum pumps are stripped for cleaning with a minimum of effort.

A shaft in a shell: The FLUX Pump F 430 with mechanical seal

Flexible coupling
between motor and
pump

Steel cored inner tube
in PP and PVDF pro-
vides the ultimate in
stability. This core
prevents elongation
of the plastics at high
temperatures. This
results in an extended
service life of the
mechanical seal

Packaging of the
mechanical seal and
rotary shaft seal
adjacent to each
other ensures the
maximum integrity of
the sealed inner tube

Impeller in ETFE



The pump must be used with many varying liquids, consequently the smallest residual left within the pump is unacceptable. You want to pump adhesive substances like paints or liquids which tend to crystallize or harden.

The inner tube houses the shaft. It is sealed at the bottom by a mechanical seal through which the shaft passes. Consequently the shaft does not come into contact with the liquid except for the small section between the impeller and seal.

Special advantages:

- The shaft support bearings are isolated from the liquid
- Steel cored inner tube in PP and PVDF pumps. This prevents elongation of the plastics, even at high temperatures
- Extended service life through well proven seal design

Here is the FLUX pump with mechanical seal the best choice.

Type F 430 – perfection in drum emptying

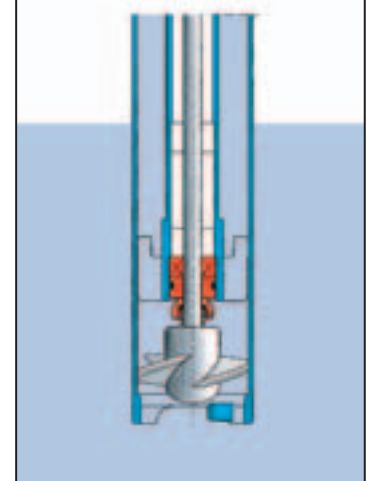

Note: For all other applications both designs – F 424 and F 430 – are equally suitable.

Most economical delivery: The FLUX Pump F 425 for emptying drums up to 99,98 %



Flexible coupling between pump and motor

Operating levers to close/open the flowback stop valve

Packaging of the mechanical seal and rotary shaft seal adjacent to each other ensures the maximum integrity of the sealed inner tube

Impeller in ETFE

Flowback stop valve

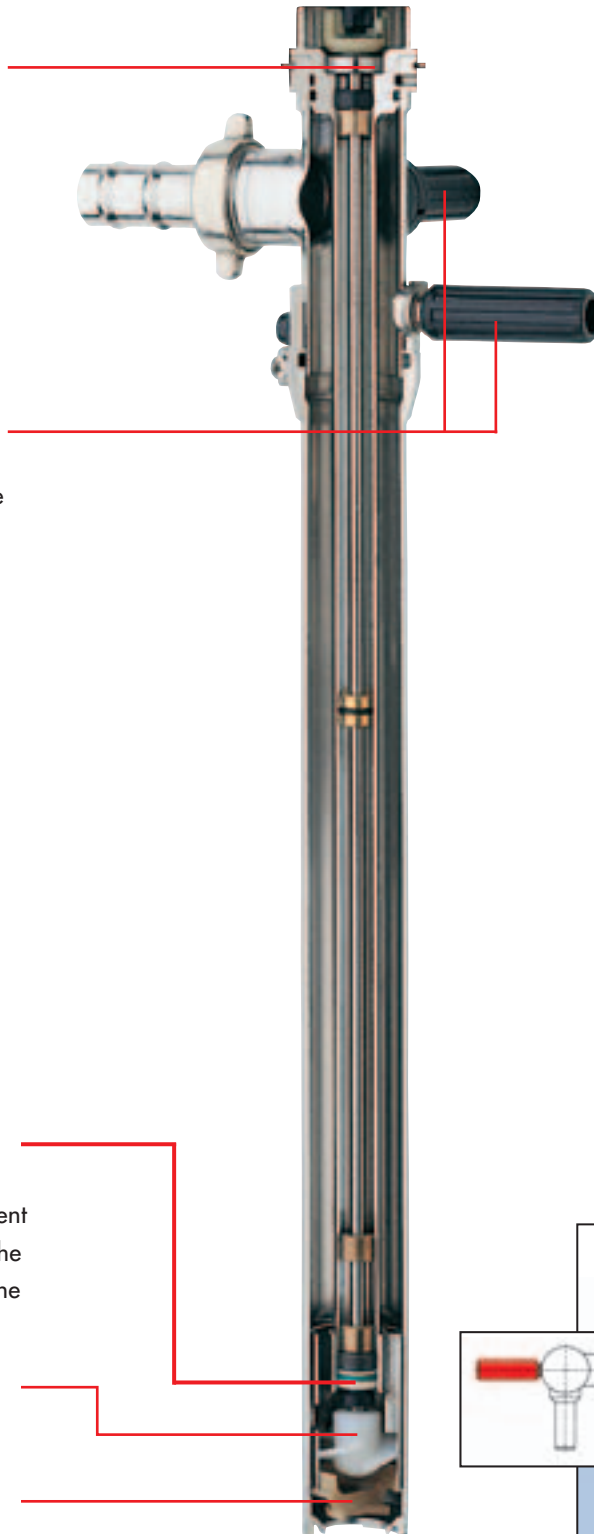

You are not prepared to accept any residual liquid in the drum in order to avoid problems and costs of disposal or to avoid losing high value liquids.

Before the motor is switched off, the flowback stop valve at the pump inlet must be closed by operating the lever. This prevents the liquid flowing back into the empty drum.

Special advantages:

- Especially easy operating of the pump
- Optimum use of the liquids
- Remains of less than 0,05 l

Here the FLUX Pump F 425 for emptying drums up to 99,98 % is your pump.

Note: All FLUX drum pumps are stripped for cleaning with a minimum of effort.

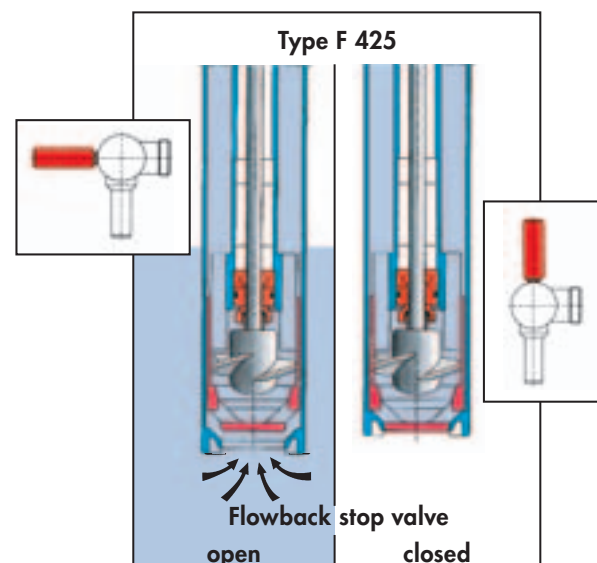

An excellent mixture: The FLUX mixing Pump F 426

Flexible coupling
between pump and
motor

Adjusting lever to set
the pump to mixing or
discharge

Mixing openings

Packaging of the
mechanical seal and
rotary shaft seal adja-
cent to each other
ensures the maximum
integrity of the sealed
inner tube

Impeller in ETFE

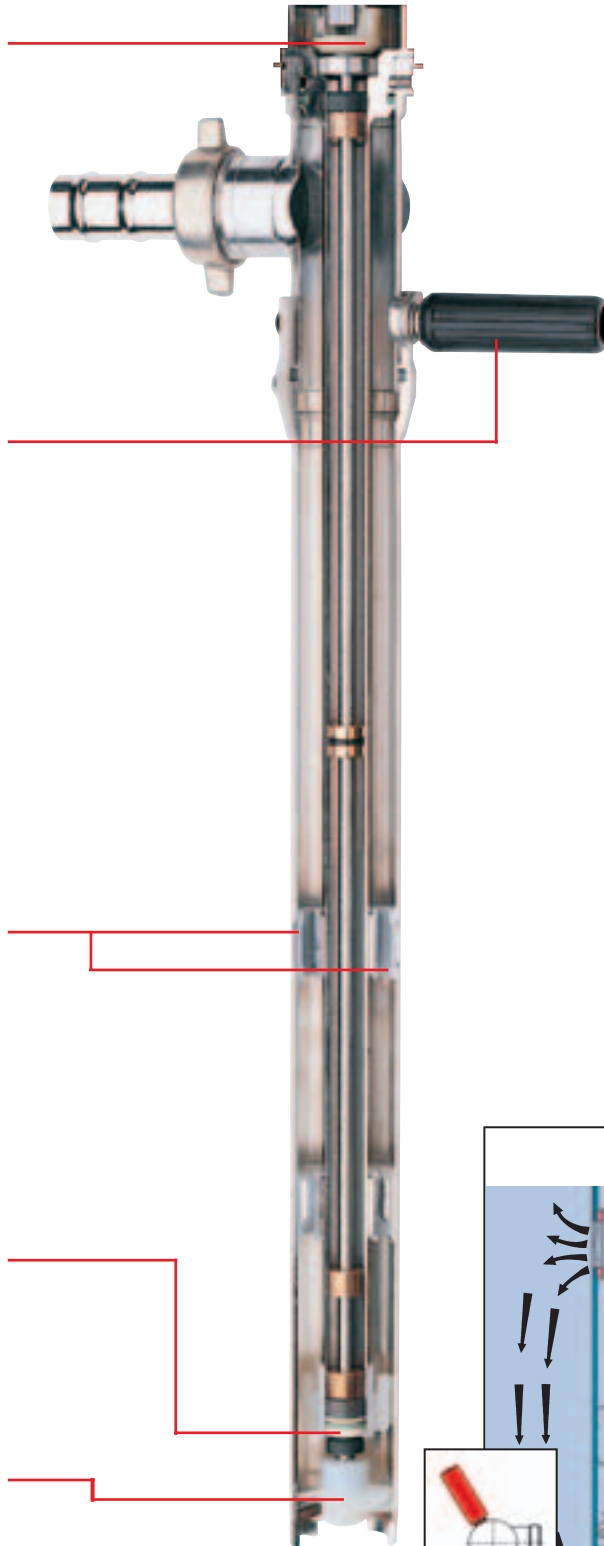

You want to mix and pump
liquids within a closed drum or
an open container.

By turning the adjusting lever, the
pump can either mix or pump.
Liquids can also be mixed even
when being transferred to
another container.

Special advantages:

- No changes in the outer diameter of the pump tube in Stainless Steels as the pump works without any additional components
- Light and handy design
- Pump/drum connection glands are also in vapour-proof version available

Here the FLUX mixing pump is
the right pump for you.

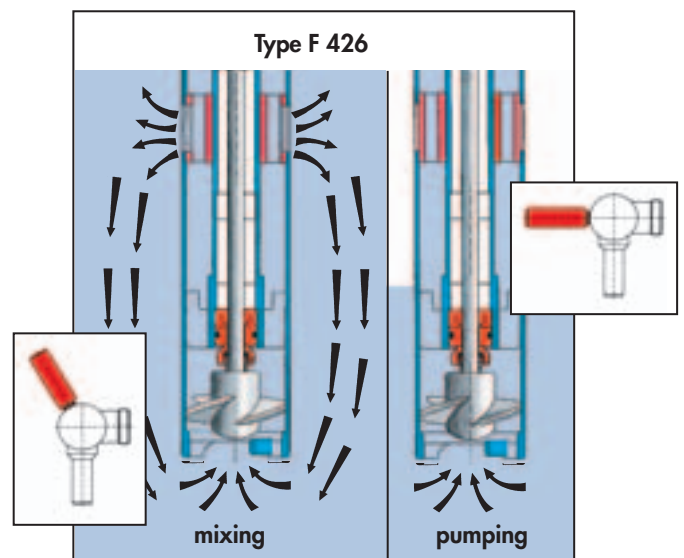

Note: All FLUX drum pumps
are stripped for cleaning
with a minimum of effort.

Pure culture in pumping: The FLUX sanitary Pump F 427



For use with all FLUX models:

Quick Action Coupling SSK 400 allows a quick assembly/disassembly of motor and pump (not included with the pump – see page 19)

Shaft seal to prevent liquids and/or vapours entering the coupling area

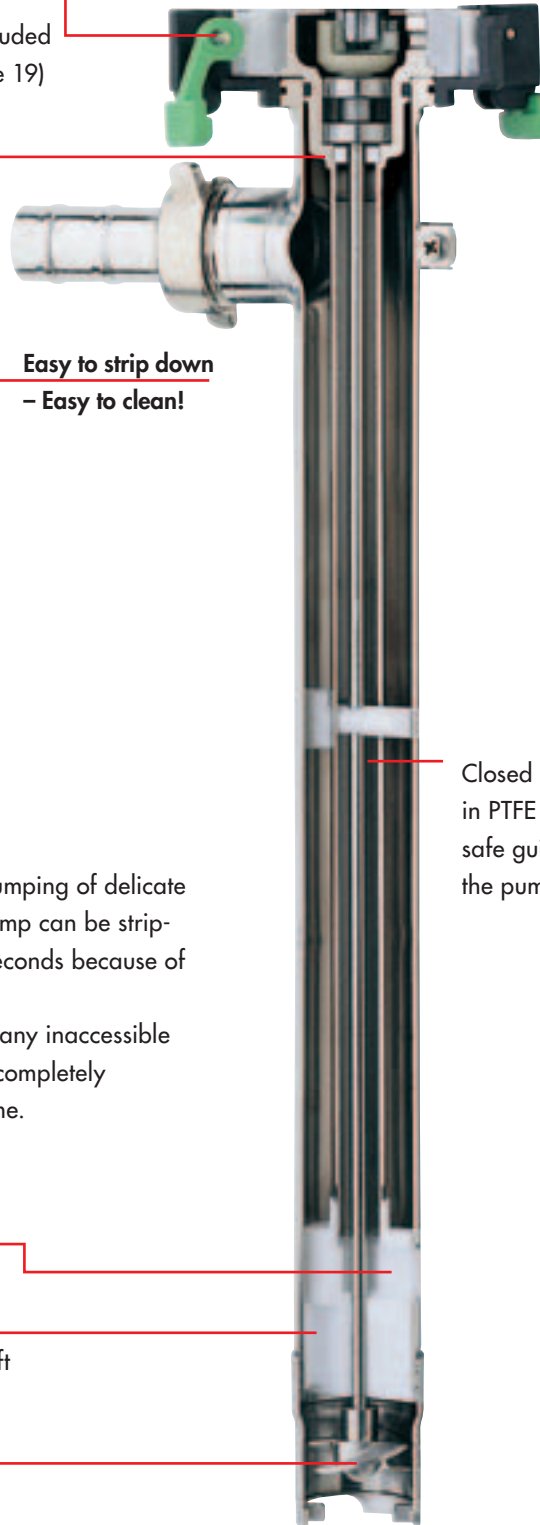

**Easy to strip down
– Easy to clean!**

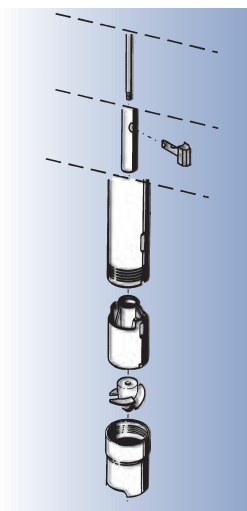

Closed bearing in PTFE assures safe guiding of the pump

FLUX facilitates aseptic pumping of delicate products. The sanitary pump can be stripped down within a few seconds because of its ingenious design.

The F 427 does not have any inaccessible voids. This allows you to completely clean the pump at any time.

Pressure relief ports

Bottom bearing assembly which centers the shaft within the inner tube

Impeller in ETFE or in stainless steel

You want a safe pumping of food, cosmetic or pharmaceutical products. The operating conditions require an easy and quick cleaning or sterilization of the pump at regular intervals to avoid any contamination of the product, e.g. when pumping varying liquids or different colours as well as quick-drying or film forming liquids.

The efficient FLUX sanitary pump has been especially designed for aseptic applications.

Special advantages:

- All wetted parts are made of Stainless Steel, PTFE or ETFE
- The pump can be quickly stripped down for cleaning or sterilization
- Negligible wear by friction on seals and bearings

Here a FLUX sanitary pump is your pump.

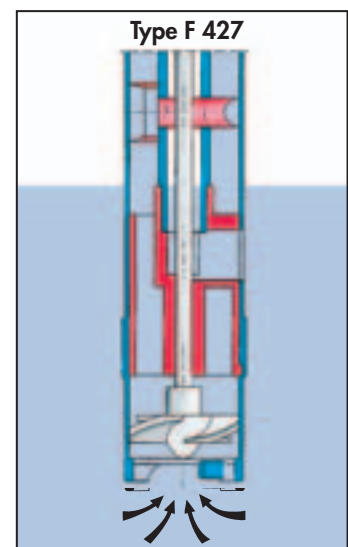

Note: All FLUX drum pumps are stripped for cleaning with a minimum of effort.

FLUX drum Pumps in Stainless Steel

FLUX drum pumps in Stainless Steel 316 Ti – except sanitary pump F 427 S – are approved according to ATEX-Directive 94/9/EC for use in Zone 0, temperature class T4, for transferring highly flammable liquids out of portable drums or containers.

With the help of the performance charts you can compare the delivery rates achieved by each pump model powered by the various FLUX motors. Detailed motor data are shown on pages 21 to 29.

When using the pump with a discharge hose (of approx. 6,5 ft) and a hand nozzle, the delivery rate will be approx. 18 GPM. Depending on the motor type a 55 GAL drum can be emptied within 3 – 4 minutes. The delivery rates shown in the performance charts are obtained at the outlet connection of the pump.

Special version for horizontal use on request.



F 424 S -43/38



FBM 4000 Ex



F 460 Ex
F 460 Ex EL
F 460-1 Ex



F 416 Ex

F 416-2 Ex



F 458
F 458 EL
F 458-1



F 414



F 457
F 457 EL



FEM 4070

↑ This pump version will achieve a higher delivery rate!

↑ This pump version will achieve a higher delivery head!

Max. viscosity per pump and motor, please see pages 28 and 29.

Motor FBM 4000 Ex

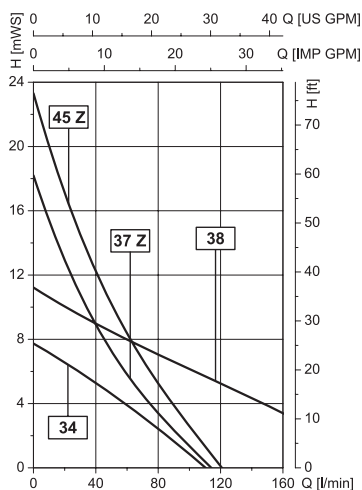

Motor F 416 Ex, F 416-1 Ex or F 416-2 Ex

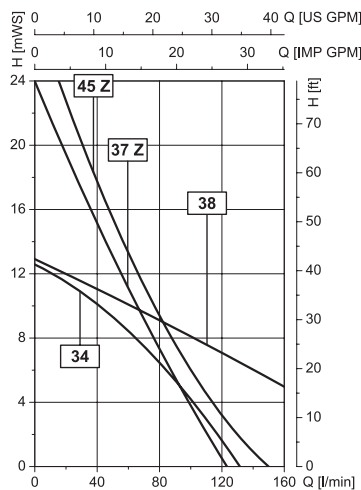

Motor FEM 4070

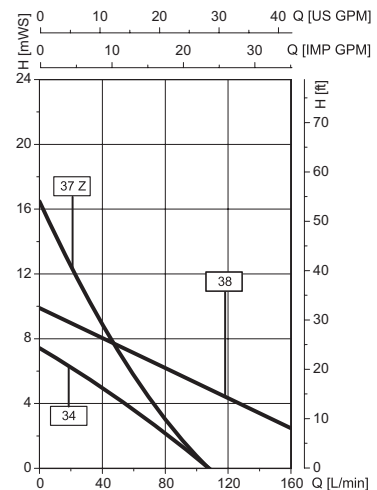

Drum Pump (tube set) in Stainless Steel, thread on outlet G 1¼ A (BSP 1¼" male), motors on page 21

Type/Curve	F 424 S-43/38	F 424 S-43/37 Z	F 424 S-50/45 Z
Version	↗	↗	↗
Seal type	sealless		
Material	shaft in Stainless Steel 316 Ti, impeller in ETFE, o-ring in FKM		
Max. temperature	212 °F		
Outer Ø	1 11/16"	1 11/16"	2"
Part No./Weight			
Immersion length 27"	424 20 007 / 4,85 lbs	424 20 107 / 4,85 lbs	424 20 207 / 6,61 lbs
Immersion length 39"	424 20 010 / 6,39 lbs	424 20 110 / 6,39 lbs	424 20 210 / 8,81 lbs
Immersion length 47"	424 20 012 / 7,27 lbs	424 20 112 / 7,27 lbs	424 20 212 / 10,6 lbs

Type/Curve	F 425 S-41/34*	F 426 S-41/38	F 427 S3-43/38
Version	99,98 % drum emptying	Mixing pump	Sanitary pump
Seal type	mechanical seal in ceramic oxide, PTFE/carbon, o-rings in FKM		sealless
Material	shaft in Stainless Steel 316 Ti, seal in FKM, impeller in ETFE		shaft in Stainless Steel 316 Ti, impeller in ETFE, o-ring in NBR
Max. temperature	212 °F		
outer Ø	1 19/32"	1 19/32"	1 11/16"
Part No./Weight			
Immersion length 27"	425 20 008 / 6,61 lbs	–	427 20 307 / 6,61 lbs
Immersion length 39"	425 20 011 / 8,37 lbs	426 20 010 / 8,37 lbs	427 20 310 / 6,39 lbs
Immersion length 47"	425 20 013 / 9,70 lbs	426 20 012 / 9,70 lbs	427 20 312 / 7,27 lbs

Type/Curve	F 430 S-41/38	F 430 S-41/37 Z	F 430 S-50/45 Z	F 430 S-50/38
Version	↗	↗	↗	↗
Seal type	mechanical seal in ceramic oxide, PTFE/carbon, o-rings in FKM			
Material	shaft in Stainless Steel 316 Ti, seal in FKM, impeller in ETFE			
Max. temperature	212 °F			
Outer-Ø	1 19/32"	1 19/32"	2"	2"
Part No./Weight				
Immersion length 27"	430 20 107 / 5,29 lbs	430 20 407 / 5,29 lbs	430 20 207 / 7,49 lbs	430 20 307 / 7,49 lbs
Immersion length 39"	430 20 110 / 6,61 lbs	430 20 410 / 6,61 lbs	430 20 210 / 9,92 lbs	430 20 310 / 9,92 lbs
Immersion length 47"	430 20 112 / 7,93 lbs	430 20 412 / 7,93 lbs	430 20 212 / 11,46 lbs	430 20 312 / 11,46 lbs

Pump models in immersion lengths of 8 – 118" (in steps of 4") on request *Model for higher delivery head on request.

Motor F 457 or F 457 EL

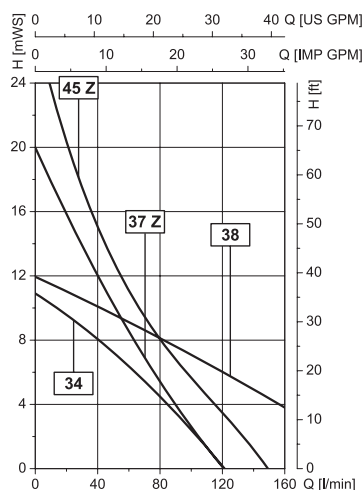

Motor F 458, F 458 EL, F 460 Ex or F 460 Ex EL

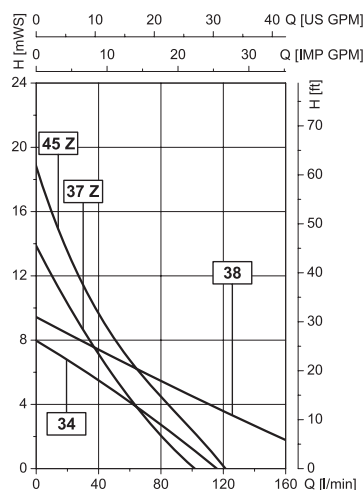

Motor F 458-1 or F 460-1 Ex

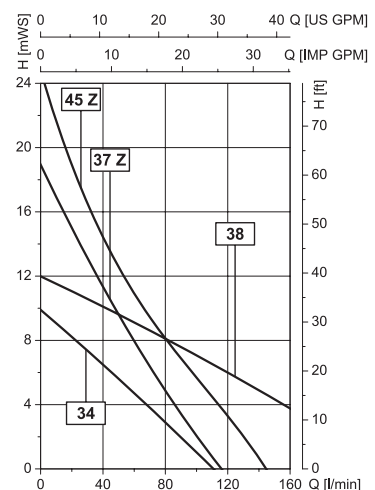

Values ± 10% with water (68 °F) and a voltage of 230 Volt.

FLUX drum Pumps in Aluminium Alloy and Hastelloy C

FLUX drum pumps in aluminium alloy ALMg5 are suitable for transferring neutral, hardly flammable liquids.

FLUX drum pumps in Hastelloy C are approved according to ATEX-Directive 94/9/EC for use in Zone 0, temperature class T4, for transferring highly flammable liquids out of portable drums or containers. In addition, Hastelloy C is chemically resistant to most of acids and alkalis, allowing the most universal use of this pump type.

With the help of the performance charts you can compare the delivery rates achieved by each pump model powered by the various FLUX motors. Detailed motor data are shown on pages 21 to 29.

When using the pump with a discharge hose (of approx. 6,5 ft) and a hand nozzle, the delivery rate will be approx. 18 GPM. Depending on the motor type a 55 GAL drum can be emptied within 3 – 4 minutes.

The delivery rates shown in the performance charts are obtained at the outlet connection of the pump.



Motor FBM 4000 Ex

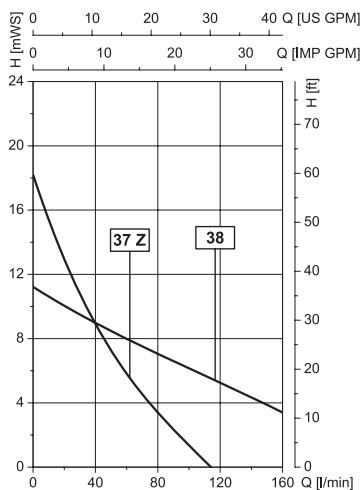

**Motor F 416 Ex, F 416-1 Ex
or F 416-2 Ex**

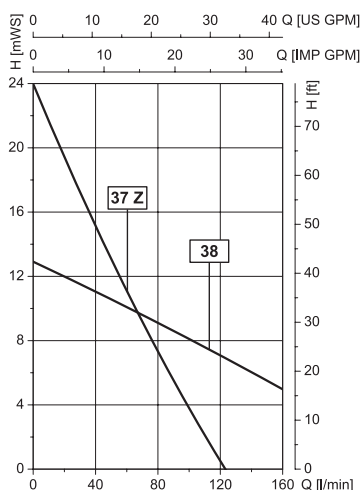

Motor FEM 4070

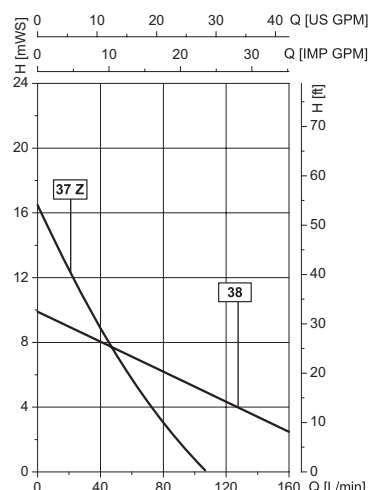

Drum Pump (tube set) in Aluminium Alloy, thread on outlet G 1¼ A (BSP 1¼" male), motors on page 21

Type/Curve	F 430 AL-41/38	F 430 AL-41/37 Z	F 430 AL-50/38
Version	↗	↗	↗
Seal type	mechanical seal in ceramic oxide, PTFE/carbon, o-rings in NBR		
Material	shaft in Stainless Steel 316 Ti, seal in NBR, impeller in ETFE		
Max. temperature	212 °F (for short periods)		
Outer-Ø	1 1/32"	1 1/32"	2"
Part No. / Weight			
Immersion length 27"	430 10 107 / 2,64 lbs	430 10 407 / 2,64 lbs	430 10 307 / 3,30 lbs
Immersion length 39"	430 10 110 / 3,30 lbs	430 10 410 / 3,30 lbs	430 10 310 / 3,96 lbs
Immersion length 47"	430 10 112 / 3,74 lbs	430 10 412 / 3,74 lbs	430 10 312 / 4,63lbs

Pump models in immersion lengths of 8 – 78" (in steps of 4") on request.

Drum pump (tube set) in Hastelloy C, thread on outlet G 1¼ A, (BSP 1¼" male), without motor

Type/Curve	F 430 HC-40/38
Version	↗
Seal type	mechanical seal in ceramic oxide, PTFE/carbon, o-rings in FFKM
Material	shaft in Hastelloy C, seal in FFKM, impeller in ETFE
Max. temperature	248 °F
Outer-Ø	1 1/16"
Part No. / Weight	
Immersion length 27"	430 30 107 / 5,07 lbs
Immersion length 39"	430 30 110 / 6,61 lbs
Immersion length 47"	430 30 112 / 7,71 lbs

Other immersion lengths on request.



This pump version will achieve a higher delivery rate!



This pump version will achieve a higher delivery head!

Max. viscosity per pump and motor, please see pages 28 and 29.

Motor F 457 or F 457 EL

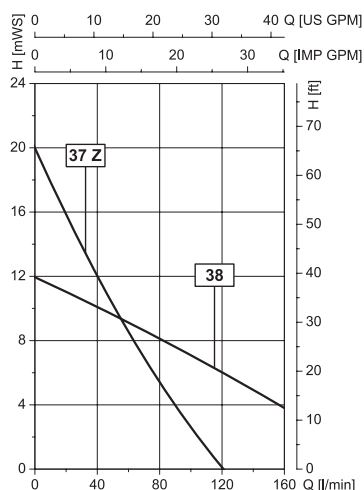

Motor F 458, F 458 EL, F 460 Ex or F 460 Ex EL

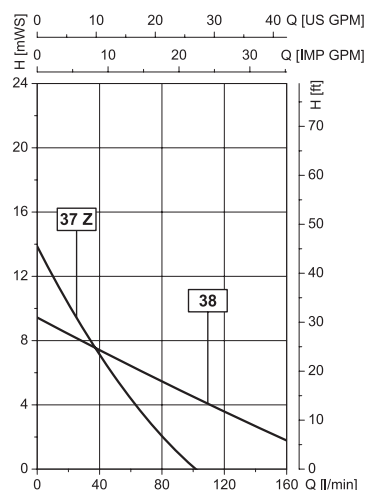

Motor F 458-1 or F 460-1 Ex

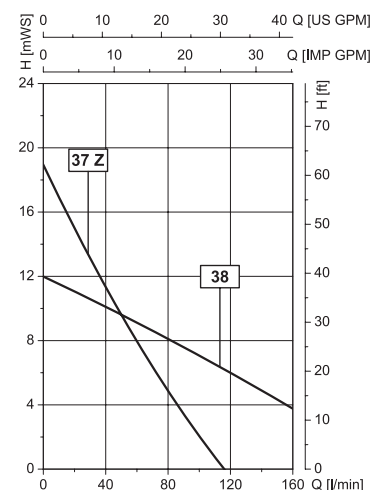

Values ± 10% with water (68 °F) and a voltage of 230 Volt.

FLUX drum Pumps in Polypropylene

FLUX drum pumps in Polypropylene are used for both chemically aggressive and hardly flammable liquids such as acids and alkalis, together with most thin and neutral liquids.

With the help of the performance charts you can compare the delivery rates achieved by each pump model powered by the various FLUX motors. Detailed motor data are shown on pages 21 to 29.

When using the pump with a discharge hose (of approx. 6,5 ft) and a hand nozzle, the delivery rate will be approx. 18 GPM. Depending on the motor type a 55 GAL drum can be emptied within 3 – 4 minutes. The delivery rates shown in the performance charts are obtained at the outlet connection of the pump.

Special version for horizontal use on request.

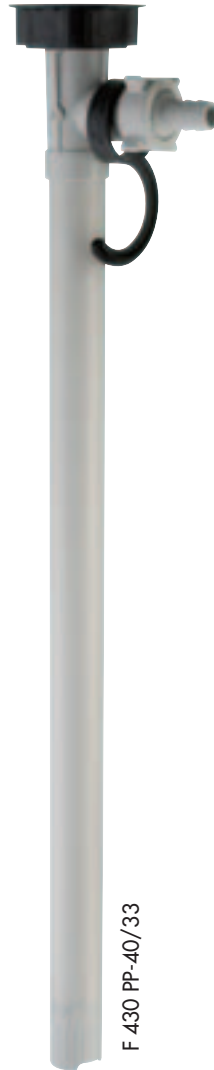

New



FEM 4070



F 457
F 457 EL



F 458
F 458 EL
F 458-1



F 414



FBM 4000 Ex



F 460 Ex
F 460 Ex EL
F 460-1 Ex

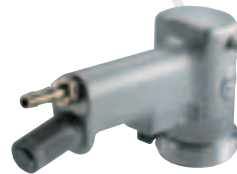

F 416 Ex

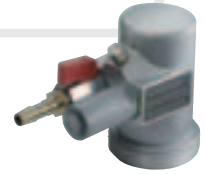

F 416-2 Ex

↑ This pump version will achieve a higher delivery rate!

↑ This pump version will achieve a higher delivery head!

Max. viscosity per pump and motor, please see pages 28 and 29.

Motor FBM 4000 Ex

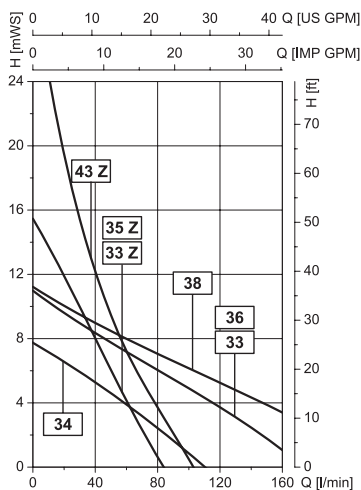

Motor F 416 Ex, F 416-1 Ex or F 416-2 Ex

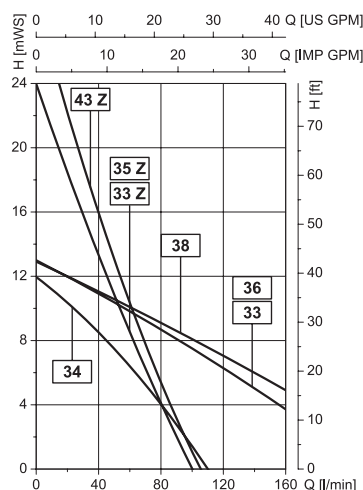

Motor FEM 4070

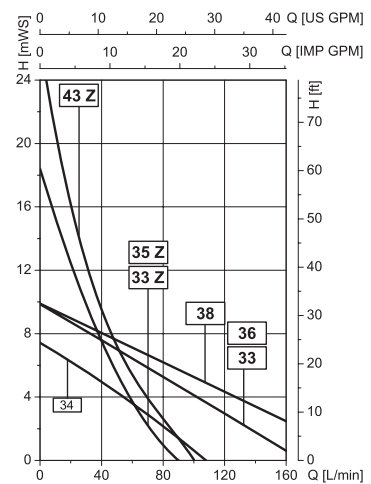

Drum Pump (tube set) in Polypropylene, thread on outlet G 1¼ A (BSP 1¼" male), motors on page 21

Type/Courbe	F 424 PP-41/36	F 424 PP-41/35 Z	F 424 PP-50/38	F 424 PP-50/43 Z
Version				
Seal type	sealless within the liquid section			
Material	shaft in Hastelloy C, impeller in ETFE, o-ring in FKM			
Max. temperature	122 °F			
Outer-Ø	1 1/32"	1 1/32"	2"	2"
Part No. / Weight				
Immersion length 27"	424 40 007 / 1,76 lbs	424 40 107 / 1,76 lbs	424 40 207 / 1,98 lbs	424 40 307 / 1,98 lbs
Immersion length 39"	424 40 010 / 2,20 lbs	424 40 110 / 2,20 lbs	424 40 210 / 2,86 lbs	424 40 310 / 2,86 lbs
Immersion length 47"	424 40 012 / 2,64 lbs	424 40 112 / 2,64 lbs	424 40 212 / 3,53 lbs	424 40 312 / 3,53 lbs
Type/Courbe	F 425 PP-50/34		F 426 PP-50/33	
Version	99,98 % drum emptying		mixing pump	
Seal type	mechanical seal in ceramic oxide, PTFE/carbon, o-rings in FKM			
Material	shaft in Hastelloy C, seal in FKM, impeller in ETFE			
Max. temperature	122 °F			
Outer-Ø	2"		2"	
Part No. / Weight				
Immersion length 27"	425 40 048 / 3,53 lbs		-	
Immersion length 39"	425 40 051 / 4,41 lbs		426 40 001 / 3,97 lbs	
Immersion length 47"	425 40 053 / 5,07 lbs		426 40 002 / 4,63 lbs	
Type/Courbe	F 430 PP-40/33	F 430 PP-40/33 Z	F 430 PP-50/43 Z	F 430 PP-50/38
Version				
Seal type	mechanical seal in ceramic oxide, PTFE/carbon, o-rings in FKM			
Material	shaft in Hastelloy C, seal in FKM, impeller in ETFE			
Max. temperature	122 °F			
Outer-Ø	1 1/16"	1 1/16"	2"	2"
Part No. / Weight				
Immersion length 27"	430 40 107 / 2,42 lbs	430 40 407 / 2,42 lbs	430 40 207 / 2,42 lbs	430 40 307 / 2,42 lbs
Immersion length 39"	430 40 110 / 3,08 lbs	430 40 410 / 3,08 lbs	430 40 210 / 3,30 lbs	430 40 310 / 3,30 lbs
Immersion length 47"	430 40 112 / 3,53 lbs	430 40 412 / 3,53 lbs	430 40 212 / 3,75 lbs	430 40 312 / 3,75 lbs
Accessories	Hose connection complete with nut G 1¼ DN 19 Part No. 959 04 053		DN 25 Part No. 959 04 052	

Pump models in immersion lengths of 8 – 118" mm (in steps of 4") on request.

Motor F 457 or F 457 EL

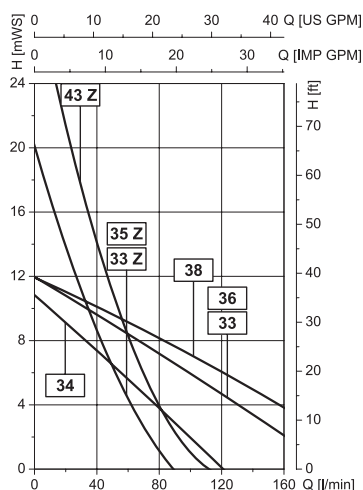

Motor F 458, F 458 EL, F 460 Ex or F 460 Ex EL

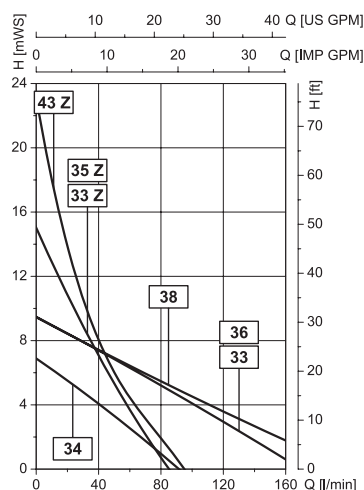

Motor F 458-1 or F 460-1 Ex

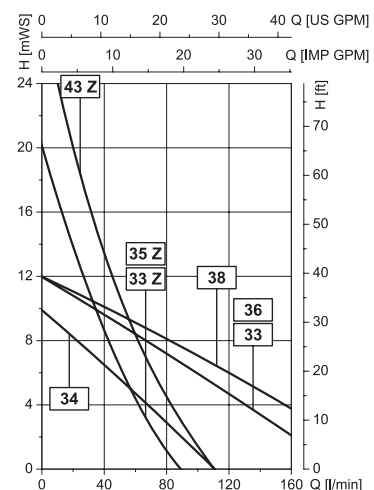

Values ± 10% with water (68 °F) and a voltage of 230 Volt.

FLUX drum Pumps in Polyvinylidene fluoride

FLUX drum pumps in Polyvinylidene fluoride are used for both chemically aggressive and hardly flammable liquids such as acids and alkalis, together with most thin and neutral liquids.

With the help of the performance charts you can compare the delivery rates achieved by each pump model powered by the various FLUX motors. Detailed motor data are shown on pages 21 to 29.

When using the pump with a discharge hose (of approx. 6,5 ft) and a hand nozzle, the delivery rate will be approx. 18 GPM. Depending on the motor type a 55 GAL drum can be emptied within 3 – 4 minutes. The delivery rates shown in the performance charts are obtained at the outlet connection of the pump.



New



FEM 4070



F 457
F 457 EL



F 458
F 458 EL
F 458-1



F 414



FBM 4000 Ex



F 460 Ex
F 460 Ex EL
F 460-1 Ex

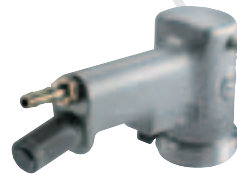

F 416 Ex

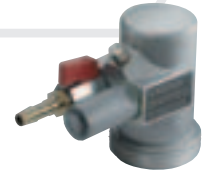

F 416-2 Ex

↖ This pump version will achieve a higher delivery rate!

↖ This pump version will achieve a higher delivery head!

Max. viscosity per pump and motor, please see pages 28 and 29.

Motor FBM 4000 Ex

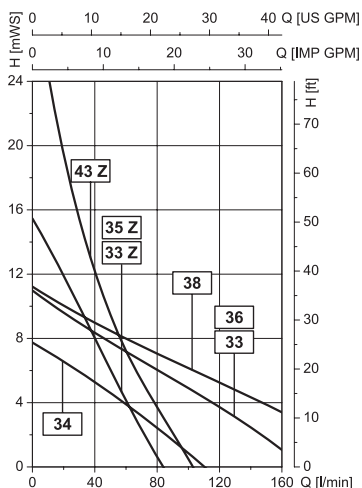

Motor F 416 Ex, F 416-1 Ex or F 416-2 Ex

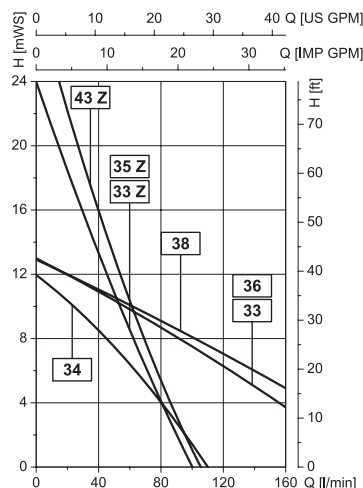

Motor FEM 4070

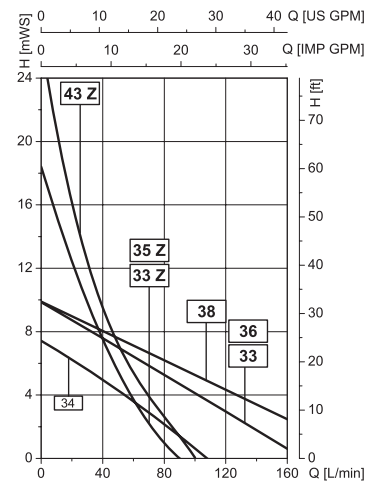

Drum Pump (tube set) in Polyvinylidene fluoride, thread on outlet, G 1¼ A (BSP 1¼" male), motors on page 21

Type/Curve	F 424 PVDF-41/36	F 424 PVDF-41/35 Z	F 424 PVDF-50/38	
Version				
Seal type	sealless			
Material	shaft in Hastelloy C, impeller in ETFE, o-ring in FKM			
Max. temperature	176 °F			
Outer-Ø	1 19/32"	1 19/32"	2"	
Part No. / Weight				
Immersion length 27"	424 60 007 / 2,42 lbs	424 60 107 / 2,42 lbs	424 60 207 / 3,08 lbs	
Immersion length 39"	424 60 010 / 3,08 lbs	424 60 110 / 3,08 lbs	424 60 210 / 4,18 lbs	
Immersion length 47"	424 60 012 / 3,53 lbs	424 60 112 / 3,53 lbs	424 60 212 / 4,85 lbs	

Type/Curve	F 430 PVDF-40/33	F 430 PVDF-40/33 Z	F 430 PVDF-50/43 Z	F 430 PVDF-50/38
Version				
Seal type	mechanical seal in ceramic oxide, PTFE/carbon, o-rings in FKM			
Material	shaft in Hastelloy C, seal in FKM, impeller in ETFE			
Max. temperature	176 °F			
Outer-Ø	1 1/16"	1 1/16"	2"	2"
Part No. / Weight				
Immersion length 27"	430 60 107 / 3,08 lbs	430 60 407 / 3,08 lbs	430 60 207 / 3,08 lbs	430 60 307 / 3,75 lbs
Immersion length 39"	430 60 110 / 3,75 lbs	430 60 410 / 3,75 lbs	430 60 210 / 3,75 lbs	430 60 310 / 4,63 lbs
Immersion length 47"	430 60 112 / 4,41 lbs	430 60 412 / 4,41 lbs	430 60 212 / 4,41 lbs	430 60 312 / 5,51 lbs

Accessories Hose connection with nut G 1¼ DN 19 Part No. 959 04 101 DN 25 Part No. 959 04 102

Pump models in immersion lengths of 8 – 118" (in steps of 4") on request.

Motor F 457 or F 457 EL

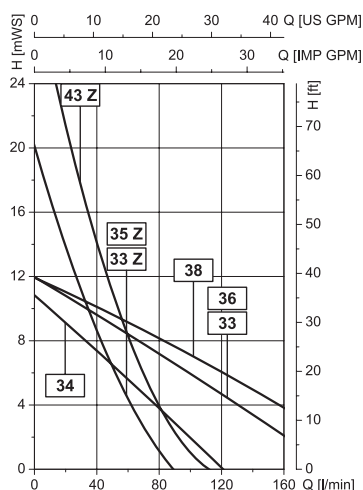

Motor F 458, F 458 EL, F 460 Ex or F 460 Ex EL

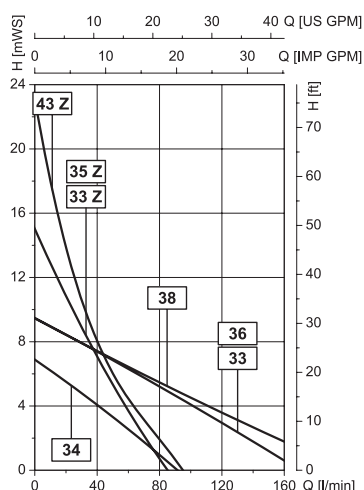

Motor F 458-1 or F 460-1 Ex

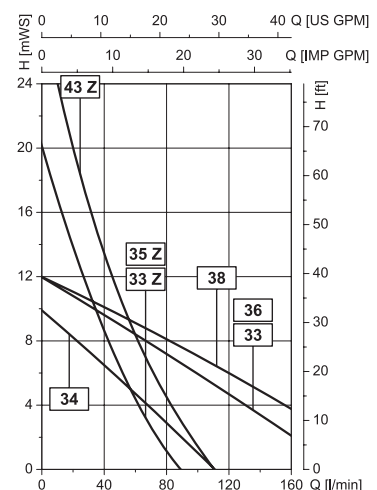

Values ± 10% with water (68 °F) and a voltage of 230 Volt.

FLUX Container Pump in Polypropylene in detail

The powerful, extremely lightweight and easy-to-handle solution for transferring corrosive acids and alkalis and almost every thin and hardly flammable liquid out of larger containers: FLUX container pump type F 430 PP-100/50 in Polypropylene. Especially designed for emptying 250 GAL-Containers, this pump provides the high safety and ease of handling you do appreciate on FLUX drum pumps.

The use of this pump allows to dispense with floor drains, to minimize leakage risks and to eliminate residual liquid within suction pipes and subsequent handling cost. A compression gland or a vapor-proof gland always secures the pump in a vertical position within the dome of the container.

Depending on the motor type, this pump will achieve a maximum delivery rate of 28 GPM and a maximum delivery head of 105 ft liquid column in transferring liquids up to a maximum viscosity

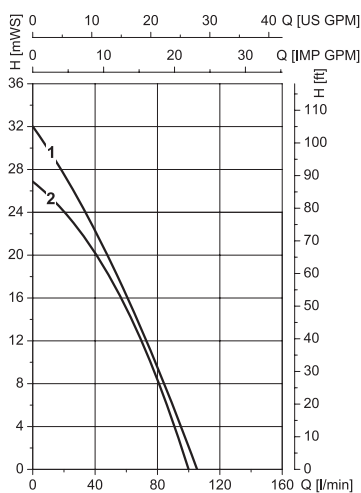

**FLUX Container Pump
F 430 PP-100/50
in combination with**

- 1 = Commutator motor
Type F 457/F 458-1**
- 2 = Three-phase gearmotor
Type F 414**

Detailed motor data
see pages 21 to 29

Values ± 10% with water (68 °F) and a voltage of 230 Volt.

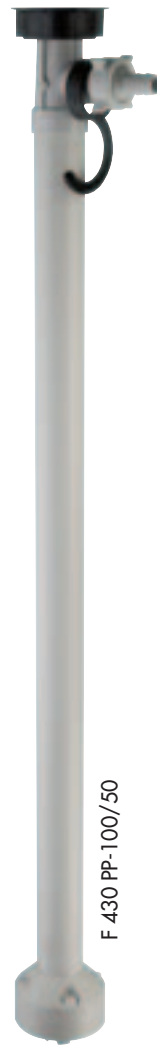

Container pump (tube set) in Polypropylene, thread on outlet G 1/4 A (BSP 1/4" male), motors on page 21

Type	F 430 PP-100/50
Version	with impeller
Seal type	mechanical seal in ceramic oxide, PTFE/carbon, o-rings in FKM
Material	shaft in Hastelloy C, seal in FKM, impeller in Polypropylene
Max. temperature	122 ° F
Outer-Ø	4" on the pump body
Part No./Weight	
Immersion length 39"	430 40 510 / 5 lbs
Immersion length 47"	430 40 512 / 5 lbs
Immersion length 60"	430 40 515 / 6 lbs
Accessories	Hose connection with nut G 1/4 DN 25 Part No. 959 04 052 DN 32 Part No. 959 04 054

Centrifugal Pumps for horizontal and vertical use		
Type	F 430 S-41/38 TR	F 430 PP-40/33 TR
Seal type	mechanical seal in ceramic oxide, PTFE/carbon, o-rings in FKM	mechanical seal in ceramic oxide, PTFE/carbon, o-rings in FKM
Material	Stainless Steel 316 Ti, seal in FKM, impeller in ETFE	Polypropylene, shaft in Hastelloy C, seal in FKM, impeller in ETFE
Dimensions	see dimensional drawing	
Max. temperature	212 °F	122 °F
Outer-Ø	1 13/32"	1 7/16"
Part No. / Weight	430 20 002 / 3 lbs	430 40 002 / 1,3 lbs
Hose connections complete for inlet		
Material	Stainless Steel 316 Ti with brass nut G 2	Polypropylene with nut G 2
DN 32	959 04 059	959 04 010
DN 38	959 04 060	959 04 011

You will find the suitable motors and performance charts for the pump F 430 S-41/38 TR on page 10 and 11, for the pump F 430 PP-40/38 TR on page 14 and 15.

Dimensions

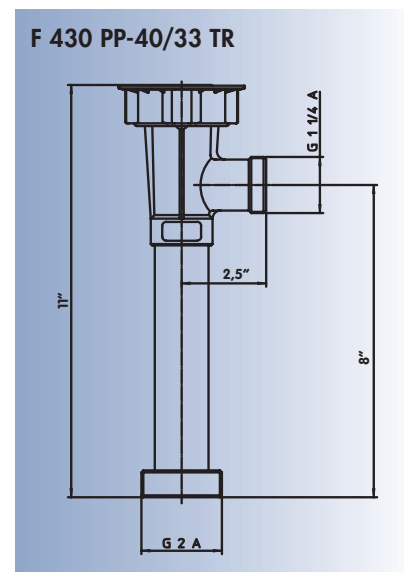
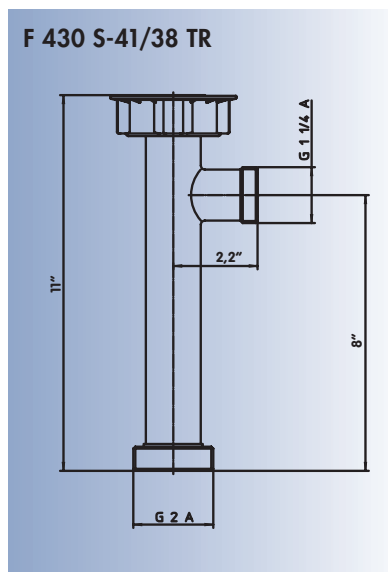

FLUX quick action coupling SSK 400

FLUX Quick Action Coupling Type SSK 400 suits all FLUX drum and container pumps Type F 424, F 425, F 426, F 427 and F 430 and allows a quick assembly/disassembly of pump and motor within a few seconds only. This allows the use of several pump tube sets with one drive motor only. The quick action coupling SSK 400 consists of a clamping element which is mounted onto the pump tube set and a threaded ring which is screwed onto the drive motor.

Type		Part No.
Quick Action Coupling SSK 400 complete	consisting of threaded ring (motor side) and clamping element (pump side)	001 10 802
or as individual parts:		
Threaded ring	to be screwed onto the drive motor	001 10 800
Clamping element	to be mounted onto the pump tube set	001 10 804





The brushless motor Type FBM 4000 Ex is featuring a compact design, a robust double shell housing in aluminium and a very low noise level. The explosion-proof motor is tested and certified according to the latest ATEX-Directive 94/9/EC.

EC-Type-Examination Certificate PTB 03 ATEX 1042.

The combined on/off switch and easy to use speed controller allow precise dispensing operations.

Electronic monitoring of speed, voltage and temperature.

An integral no-volt release monitors the power and prevents unintentional re-start of the pump. This feature ensures additional safety for the user.

Due to negligible wear, the brushless motor design guarantees lowest cost of ownership, even with continuous use.



Brushless motor, explosion-proof to II 2 G EEx de IIC T5, protection class I. Jet-proof according to IP 55. With power supply cable, 16" long, with safety plug (not explosion-proof).

Type	Capacity	Voltage	Frequency	Weight	Part No. Version
					with no-volt release safety circuit
FBM 4000 Ex	600 W	230 V	50 – 60 Hz	13,66 lbs	400 01 000
Accessories					Part No.
Carrying handle	allowing easy immersion and removal of the pump				001 10 557

FLUX commutator motor F 460 Ex in detail

Explosion-proof commutator motor Type F 460 Ex featuring a compact design, a robust double shell housing in aluminium and a very low noise level. Tested and certified according to ATEX-Directive 94/9/EC.

Type F 460 Ex EL, 230 Volt, with infinitely variable speed control included in the switch knob for an easy control of the delivery rate.

EC-Type-Examination Certificate PTB 97 ATEX 1035.

An improved ventilation system provides optimal cooling and ensures an extended service life.

Additional safety by an integral no-volt release to prevent from any unintentional re-starting after a voltage discontinuity.

The commutator motor Type F 460-1 Ex is identical with Type F 460 Ex, but has a considerably higher capacity of 700 Watt. This model is recommended for applications requiring a higher delivery rate or when transferring medium viscosity products or liquids with a higher density.

120 V, 60 Hz version UL-listed, File No. E67399, class I, group C + D.



F 460 Ex (pict)
F 460 Ex EL
F 460-1 Ex

Commutator motor, explosion-proof to II 2 G EEx de IIC T6, protection class I in 230, 240 or 110 Volt, protection class III in 42, 24 or 12 Volt. Jet-proof according to IP 55, version with no-volt release, with power supply cable, 16" long, with safety plug (not explosion-proof). – 42, 24 and 12 Volt version without plug.

Type	Capacity	Voltage	Frequency	Weight	Part No. Version	
					with variable speed control	without variable speed control
						
F 460 Ex UL	460 W	120 V	60 Hz	11,24 lbs	–	460 00 031
F 460 Ex	460 W	230 V	50 – 60 Hz	11,24 lbs	–	460 00 026
F 460 Ex	410 W	24 V	DC	11,24 lbs	–	460 00 003
F 460 Ex	230 W	12 V	DC	11,24 lbs	–	460 00 004
F 460 Ex EL	230 W	230 V	50 Hz	11,24 lbs	460 00 028	–
F 460-1 Ex UL	700 W	120 V	60 Hz	13,00 lbs	–	460 01 024
F 460-1 Ex	700 W	230 V	50 – 60 Hz	13,00 lbs	–	460 01 001
Accessories					Part No.	
Earth (ground) wire with crocodile clip	6,6 ft long 6,6 ft long, reinforced version 9,8 ft long				931 90 008 931 90 015 931 90 013	
Carrying handle	allowing easy immersion and removal of the pump in combination with commutator motors Type F 460 Ex, F 460 Ex EL, F 460-1 Ex or FBM 4000 Ex.				001 10 557	

FLUX commutator motor F 458 in detail



Commutator motor Type F 458 featuring a compact design, a robust double shell housing in aluminium and a very low noise level.

Type F 458 EL, 230 Volt, with infinitely variable speed control included in the switch knob for an easy control of the delivery rate. An improved ventilation system provides optimal cooling and ensures an extended service life. Totally enclosed, fan cooled motor design and special corrosion resistant painting, making these models particularly suitable for use in corrosive, vapour laden atmospheres.

Additional safety by an integral no-volt release to prevent from any unintentional re-starting after a voltage discontinuity.

The commutator motor Type F 458-1 is identical with Type F 458, but has a considerably higher capacity of 700 Watt. This model is recommended for applications requiring a higher delivery rate or when transferring products with a medium viscosity or liquids with a higher density.

120 V, 60 Hz version approved to CSA standards, File No. LR 39984-7.



F 458 (pict)
F 458 EL
F 458-1

Commutator motor, special corrosion-resistant painting, protection class I in 240, 230 and 110 Volt. Protection class III in 24 or 12 Volt, Jet-proof according to IP 55, with no-volt release, power supply cable, 16" long, and safety plug. – 24 and 12 Volt version without plug.

Type	Capacity	Voltage	Frequency	Weight	Part No. Version	
					with variable speed control	without variable speed control
F 458 CSA	460 W	120 V	60 Hz	11,24 lbs	–	458 00 026
F 458	460 W	230 V	50 – 60 Hz	11,24 lbs	–	458 00 025
F 458	410 W	24 V	DC	11,24 lbs	–	458 00 003
F 458	230 W	12 V	DC	11,24 lbs	–	458 00 004
F 458 EL	460 W	230 V	50 Hz	11,24 lbs	458 00 027	–
F 458-1 CSA	700 W	120 V	60 Hz	13,00 lbs	–	458 01 021
F 458-1	700 W	230 V	50 – 60 Hz	13,00 lbs	–	458 00 020
Accessories					Part No.	
Carrying handle	allowing easy immersion and removal of the pump in combination with commutator motors Type F 458, F 458 EL or F 458-1				001 10 557	

Note: For transferring highly flammable liquids and for use in hazardous areas explosion-proof motors must be used.

FLUX commutator motors FEM 4070 and F 457 in detail

New

The new fully electronic adjustable drum pump motor FEM 4070 with integrated no-volt release ensures optimum safety during the filling process. The 500 Watt power pack is equipped with 4 speed ranges. The ergonomically designed handle ensures a safe one-handed operation of the rotary switch for starting the pump and choosing the speed ranges via the touch button.

Additional benefits for the new FEM 4070:

- Electronic adjustable, complete overload protection in all 4 speed ranges
- Motor with no-volt release, thus ensuring optimum safety during the filling process
- 500 Watt electronic adjustable power pack with 4 speed ranges
- Preset speed range remains in case of a re-start
- Lifting eye for use with inertia hoist
- Automatically filling process within defined flow rates in conjunction with our FLUX flow meters
- Speed range adjustment via touch button
- Compact design
- Low noise level
- High durability
- Modern, application-oriented design
- Safe starting by rotary switch
- Favourable efficiency weight
- Advanced flow rate
- The motor can be combined with Stainless steel, Aluminium, Hastelloy C, Polypropylene and PVDF pumps
- For transferring neutral, aggressive, non flammable liquids



FEM 4070



F 457 (pict)
F 457 EL

Powerful commutator motor Type F 457 featuring a compact design, an optimal cooling system, a low noise level and an extended service life.

Extremely light-weight and easy to handle, allowing a most universal use with neutral, corrosive, hardly flammable liquids.

Type F 457 EL with infinitely variable speed control device for an easy control of the delivery rate.

Commutator motor FEM 4070

double isolated according to protection class II, IP 24 splash-proof, with electronic and thermal overload protection, electronic adjustable power pack with 4 speed ranges, 16" cable and plug.

Type	Capacity	Voltage	Frequency	Weight	Part No. Version	
					with no-volt release	without no-volt release
FEM 4070	500 W	120 V	60 Hz	5,8 lbs	407 01 012	407 01 013
FEM 4070	500 W	230 V	50 – 60 Hz	5,8 lbs	407 01 023	–

Commutator motor F 457

double isolated according to protection class II, IP 24 splash-proof, with power supply cable, 16" long and 2-pole plug.

Type	Capacity	Voltage	Frequency	Weight	Part No. Version	
					with no-volt release, with variable speed control	with no-volt release, without variable speed control
F 457	800 W	120 V	60 Hz	8,82 lbs	–	457 01 000
F 457 EL	800 W	120 V	60 Hz	8,82 lbs	457 01 001	–
F 457	800 W	230 V	50 – 60 Hz	8,82 lbs	–	457 01 037
F 457 EL	800 W	230 V	50 – 60 Hz	8,82 lbs	457 01 003	–

Other voltages and/or frequencies on request.

Accessories		Part No.
Carrying handle	allowing an easy immersion and removal of the pump. In combination with commutator motor F 457 or F 457 EL	001 10 533

Note: For transferring highly flammable liquids and for use in hazardous areas explosion-proof motors must be used.

FLUX three-phase gearmotor F 414 in detail

The robust three-phase gearmotor F 414 is especially designed for extreme operating conditions and extended operating periods.



F 414

Three-phase Gearmotor, protection class I, jet-proof to IP 55, available with motor protection switch or with cable terminal box, without power supply cable.

Type	Capacity	Voltage	Frequency	Range of setting motor protection switch	Weight	Part No. Version	
						with motor protection switch, mounted on the motor	without motor protection switch, with cable terminal box
F 414	0,55 kW	230/400 V	50 Hz	0,9 – 1,6 A	19/18 lbs	414 01 112	414 01 110
F 414	0,75 kW	230/400 V	50 Hz	1,5 – 2,5 A	25/23 lbs	414 01 123	414 01 122
F 414	1,1 kW	230/400 V	50 Hz	2,4 – 3,5 A	28/26 lbs	414 01 131	414 01 130

Accessories:		Part No.
Carrying handle	allowing an easy immersion and removal of the pump in combination with the Three-phase Gearmotor F 414	001 10 582
Power supply cable	16 ft long, complete with Cekon plug, 5-pole	934 08 020
Power supply cable	16 ft long, without plug	934 08 025
Power supply cable	yard ware	934 08 901
Cekon plug	5-pole	937 01 014

Motor F 414 in combination with drum pump in Stainless steel

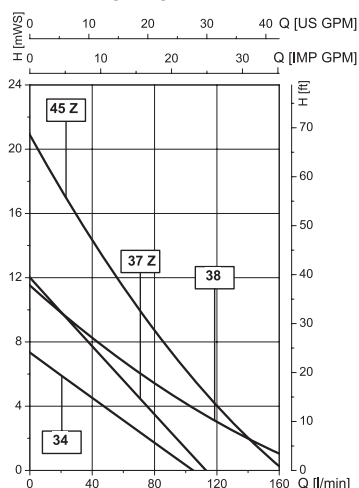

Motor F 414 in combination with drum pump in Aluminium and Hastelloy C

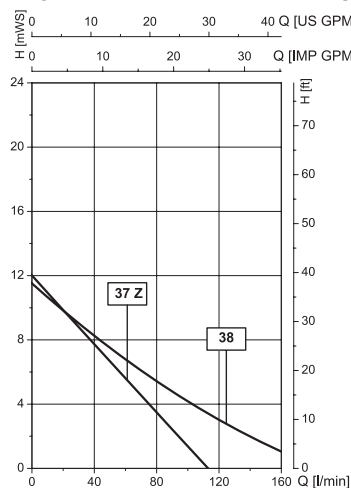

Motor F 414 in combination with drum pump in PP and PVDF

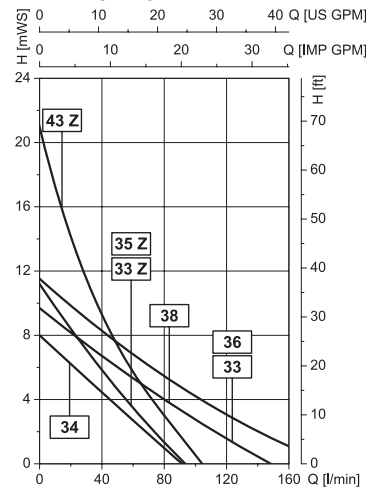

Values ± 10% with water (68 °F) and a voltage of 230 Volt.

In combination with air motors FLUX drum and container pumps are very lightweight, easy to handle and extremely powerful at the same time.

FLUX air motors are explosion-proof according to ATEX-Directive 94/9/EC. PTB Registration No. 02 ATEX D022.

These motors are recommended for transferring highly flammable liquids and are particularly suitable for applications requiring a powerful and easy to adjust motor.

The speed can be adjusted via the filter-regulator-lubricator unit on models F 416 Ex and F 416-1 Ex or on a ball valve on model F 416-2 Ex.

Power at 86 psi operating pressure – 470 Watt.

Power at 43 psi operating pressure – 170 Watt.

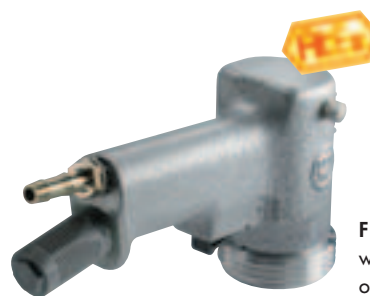

F 416 Ex
with trigger
operated valve

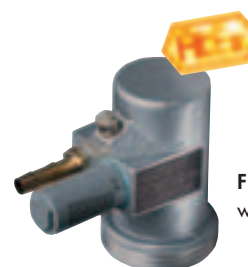

F 416-1 Ex
without valve

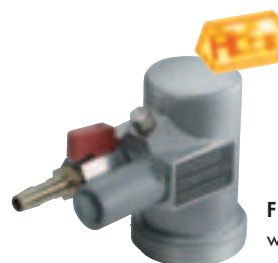

F 416-2 Ex
with ball valve

Air Motor, explosion-proof to II 2 G cp IIC T6, easily variable speed control by adjusting either the air supply pressure or volume, motor overload-proof, air connection G ¼ (BSP ¼" female).

Type	Capacity	Operating pressure max.	Air consumption	Version	Weight	Part No.
F 416 Ex	470 W	86 psi	17 cfm	with trigger operated valve	3,10 lbs	416 00 122
F 416-1 Ex	470 W	86 psi	17 cfm	without valve	2,00 lbs	416 00 125
F 416-2 Ex	470 W	86 psi	17 cfm	with ball valve	2,20 lbs	416 00 030

Other voltages and/or frequencies on request.

Accessories:		Part No.
Filter-regulator-lubricator unit	consisting of water separator, pressure gauge and lubricator. Thread on inlet and outlet BSP ¼" female	001 10 100
Compressed air hose	DN 10, electrically conductive (blue)	001 10 098
Hose coupling	brass, spring-actuated, with hose nozzle DN 10 for compressed air hose	959 13 066
Nipple	brass, DN 10 – BSP ¼" male for hose coupling	959 13 065
Hose nozzle	brass, DN 10 – BSP ¼" male for compressed air hose	959 05 022
Earth (ground) wire with crocodile clip	6,6 ft long 6,6 ft long, reinforced version 9,8 ft long	931 90 008 931 90 015 931 90 013

Capacity range



Motor Type	FBM 4000 Ex			F 458 F 458 EL	F 460 Ex F 460 Ex EL		F 458-1	F 460-1 Ex		
Pump tube set Type	Delivery rate* GPM	Delivery head** ft	Viscosity max. cP	Delivery rate* GPM	Delivery head** ft	Viscosity max. cP	Delivery rate* GPM	Delivery head** ft	Viscosity max. cP	
F 430 S-41/38	58	36	800	53	31	800	58	39	700	
F 430 S-41/37 Z	29	57	1000	26	46	1000	30	62	900	
F 430 S-50/38	58	36	800	53	31	800	58	39	700	
F 430 S-50/45 Z	32	75	800	34	62	900	38	82	900	
F 424 S-43/38	58	36	800	53	31	800	58	39	700	
F 424 S-43/37 Z	29	57	1000	26	46	1000	30	62	900	
F 424 S-50/45 Z	32	75	800	34	62	900	38	82	900	
F 425 S-41/34	29	26	800	30	26	800	30	33	900	
F 426 S-41/38	58	36	800	53	31	800	58	39	700	
F 427 S3-43/38	58	36	800	53	31	800	58	39	700	
F 430 AL-41/38	58	36	800	53	31	800	58	39	700	
F 430 AL-41/37 Z	29	57	1000	26	46	1000	30	62	800	
F 430 AL-50/38	58	36	800	53	31	800	58	39	700	
F 430 HC-40/38	58	36	800	53	31	800	58	39	700	
F 430 PP/PVDF-40/33	42	34	800	45	31	800	50	39	900	
F 430 PP/PVDF-40/33 Z	22	51	1000	22	49	1000	24	66	900	
F 430 PP/PVDF-50/38	58	36	800	53	31	800	58	39	700	
F 430 PP/PVDF-50/43 Z	28	98	1000	25	75	1000	29	92	900	
F 424 PP/PVDF-41/36	46	36	800	45	31	800	50	39	900	
F 424 PP/PVDF-41/35 Z	22	51	1000	22	49	1000	24	66	900	
F 424 PP/PVDF-50/38	58	36	800	53	31	800	58	39	700	
F 424 PP-50/43 Z	33	98	1000	25	75	1000	29	92	900	
F 425 PP-50/34	29	26	800	24	23	1000	29	33	900	
F 426 PP-50/33	42	34	800	45	31	800	50	39	900	

Values ± 10 % with water (68 °F) and a voltage of 230 Volt.



	F 414			F 416 Ex	F 416-1 Ex F 416-2 Ex		FEM 4070			F 457	F 457 EL	
	Delivery rate* GPM	Delivery head** ft	Viscosity max. cP	Delivery rate* GPM	Delivery rate** ft	Viscosity max. cP	Delivery rate* GPM	Delivery head** ft	Viscosity max. cP	Delivery rate* GPM	Delivery head** ft	Viscosity max. cP
	49	36	900	63	43	1000	57	33	600	58	39	800
	30	39	1000	32	79	1200	28	52	800	32	66	1000
	49	36	900	63	43	1000	57	33	600	58	39	800
	42	69	1000	38	98	1200	-	-	-	40	85	900
	49	36	900	63	43	1000	57	33	600	58	39	800
	30	39	1000	32	79	1200	28	52	800	32	66	1000
	42	69	1000	38	98	1200	-	-	-	40	85	900
	26	23	1000	34	43	1200	28	24	800	32	36	900
	49	36	900	63	43	1000	57	33	600	58	39	800
	49	36	900	63	43	1000	57	33	600	58	39	800
	49	36	900	63	43	1000	57	33	600	58	39	800
	30	39	1000	32	79	1200	28	52	800	32	66	1000
	49	36	900	63	43	1000	57	33	600	58	39	800
	49	36	900	63	43	1000	57	33	600	58	39	800
	38	33	1000	54	43	1200	43	31	600	50	39	800
	24	36	1000	26	79	1200	22	59	600	24	66	1000
	49	36	900	63	43	1000	57	33	600	58	39	800
	28	69	1000	28	98	1200	26	85	800	29	98	900
	38	33	1000	54	43	1200	43	31	600	50	39	800
	24	36	1000	26	79	1200	22	59	800	24	66	1000
	49	36	900	63	43	1000	43	33	600	58	39	800
	28	69	1000	28	98	1200	26	85	800	29	98	900
	24	26	1000	29	39	1200	28	24	800	32	36	1000
	38	33	900	54	43	1200	43	31	800	50	39	800

* Maximum delivery rate with free outlet; obtained on the outlet connection.

** Maximum delivery head with closed outlet; obtained on the outlet connection.

General view FLUX Drum and Container Pump with accessories for highly flammable liquids (explosion-proof version)

It is not merely the pump that makes the FLUX solution a perfect equipment. On this page you will find a general view on the explosion-proof FLUX drum pump together with all accessories for transferring highly flammable liquids. With all items in bold printing you will have a ready to use pump assembly, which may be completed by other accessories shown on this page.

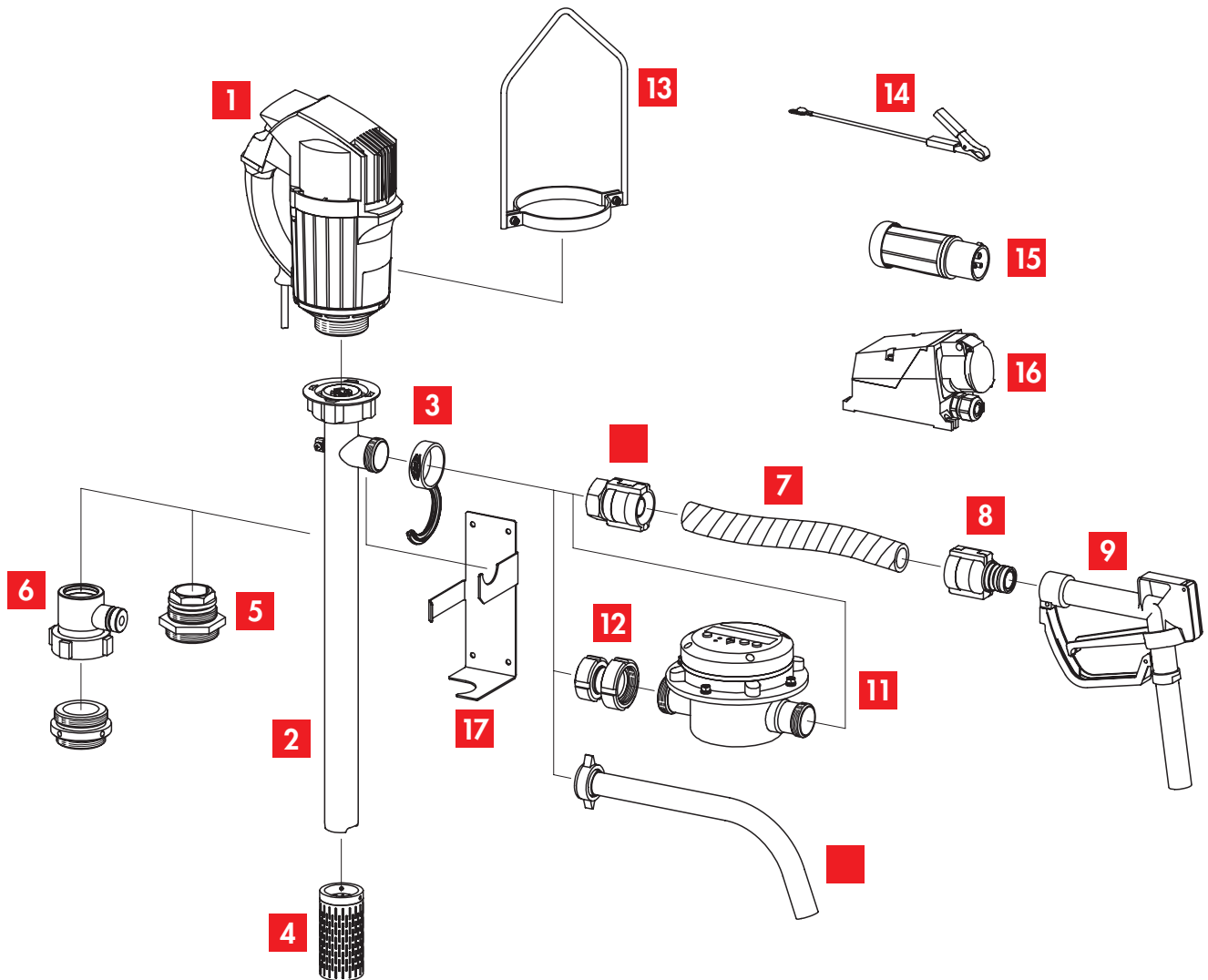

- | | |
|------------------------------------|------------------------------------|
| 1 Drive Motor | 10 Discharge spout |
| 2 Drum Pump (pump tube set) | 11 Liquid meter |
| 3 FLUX-Clip | 12 Connecting piece FMC 100 |
| 4 Suction strainer | 13 Carrying handle |
| 5 Compression gland | 14 Earth (ground) wire |
| 6 Fume gland Type FES | 15 Explosion-proof plug |
| 7 Flexible hose* | 16 Explosion-proof socket |
| 8 Swaged hose fittings* | 17 Wall bracket |
| 9 Quick action tap | |

* On request also available completely mounted and tested for electrical conductivity.

General view FLUX Drum and Container Pump with accessories for non-flammable liquids



It is not merely the pump that makes the FLUX solution a perfect equipment. On this page you will find a general view on the FLUX drum pump together with all accessories for transferring non-flammable liquids. With all items in bold printing you will have a ready to use pump assembly, which may be completed by other accessories shown on this page.

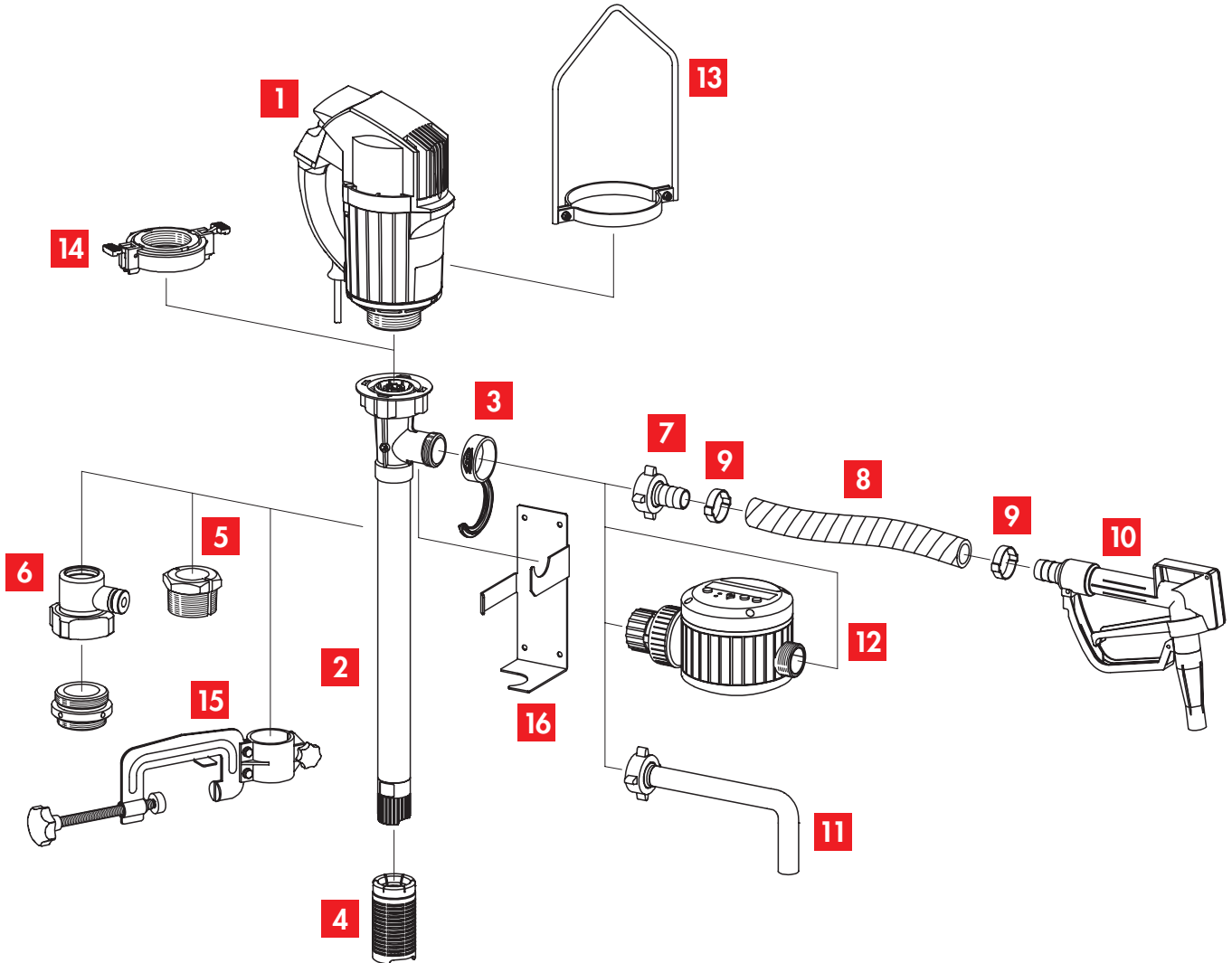

- | | |
|------------------------------------|--|
| 1 Drive Motor | 9 Hose clip |
| 2 Drum Pump (pump tube set) | 10 Quick action tap |
| 3 FLUX-Clip | 11 Discharge spout |
| 4 Suction strainer | 12 Liquid meter |
| 5 Compression gland | 13 Carrying handle |
| 6 Fume gland Type FES | 14 Quick action coupling Type SSK 400 |
| 7 Hose connection | 15 Attachment clamp |
| 8 Flexible hose* | 16 Wall bracket |

Dimensions

FEM 4070

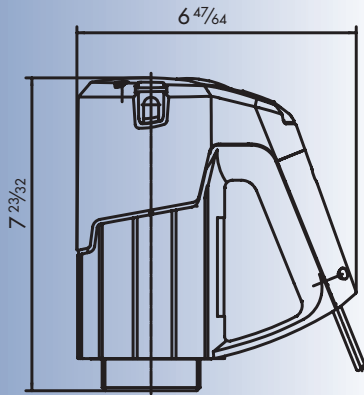

F 457/F 457 EL

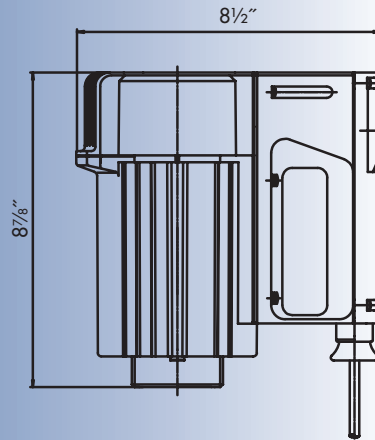

F 458/F 458 EL/F 458-1/
F 460 Ex/F 460 Ex EL/
F 460-1 Ex/FBM 4000 Ex

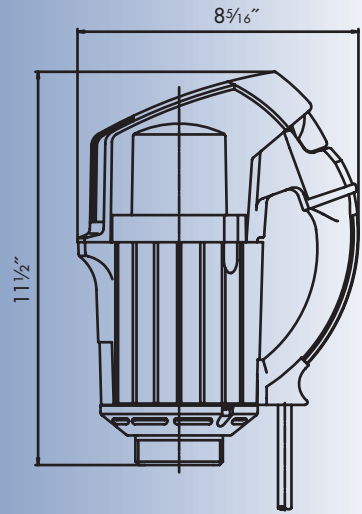

F 416 Ex

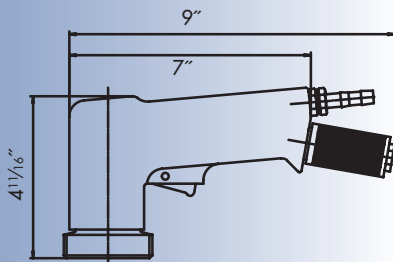

F 416-1 Ex

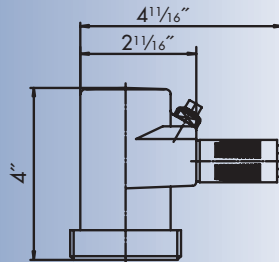

F 416-2 Ex

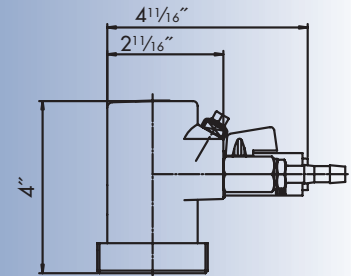

F 414

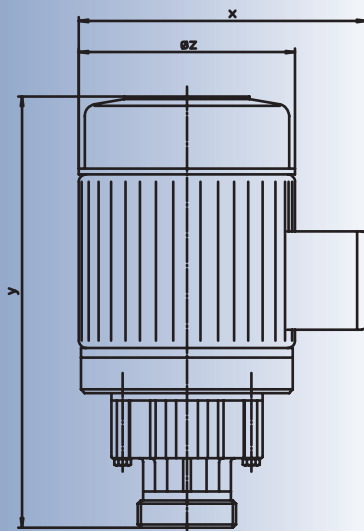

Type F 414

Capacity	X	Y	Øz
0,55 kW	8"	11"	5 19/32"
0,75 kW	8 1/2"	12"	6 3/16"
1,1 kW	8 1/2"	12"	6 3/16"

Note: with motor and pump assembled, the total length reduces by 5/8".

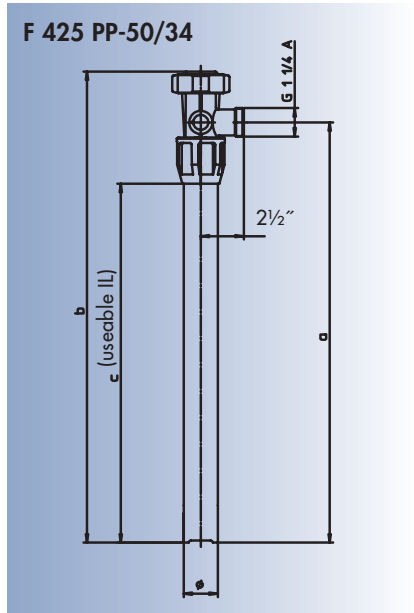
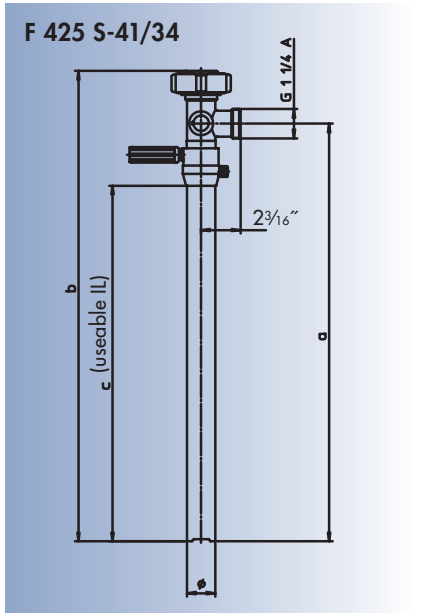
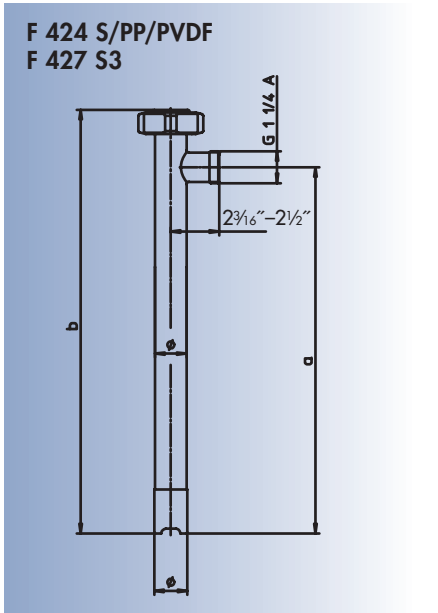

Type	F 424 S/PP/PVDF and F 427 S3			F 425 S-41/34			F 425 PP-50/34		
Dimensions	Ø	a	b	a	b	c	a	b	c
Immersion length 27"	S: 1 1/16" or 2"	28"	31"	32"	35"	29"	32"	35"	28 1/2"
Immersion length 39"	PP/PVDF: 1 1/32" or 2"	40"	43"	44"	47"	41"	44"	47"	40 1/2"
Immersion length 47"		48"	51"	52"	55"	49"	52"	55"	48 1/2"
	on models PP/PVDF-41/35 Z, dimensions a and b are reduced by 3/16".			with open valve dimensions a and b are increased by 17/64".			with open valve dimensions a and b are increased by 3/16".		

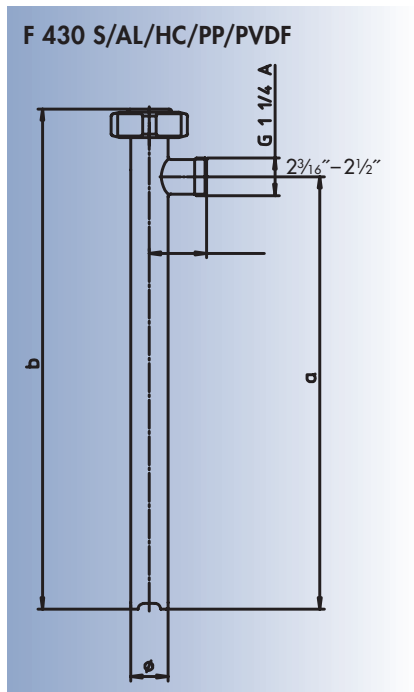
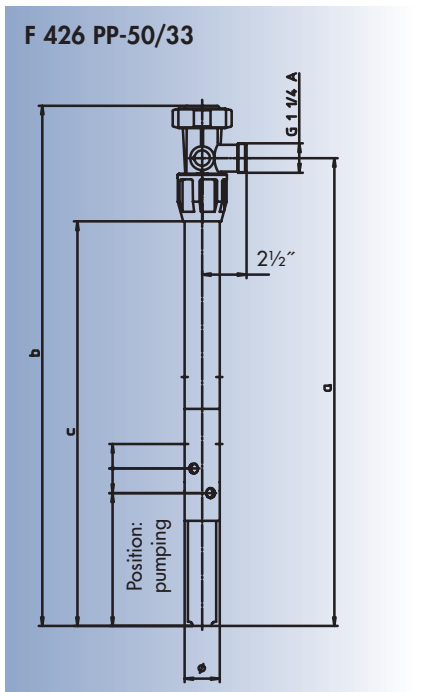
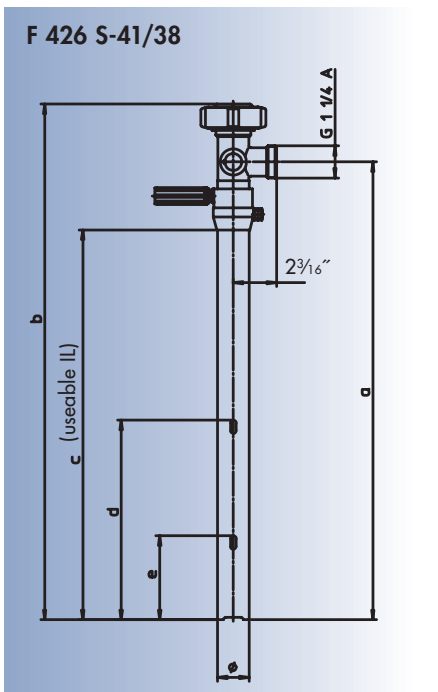

Type	F 426 S-41/38					F 426 PP-50/33			F 430 S/AL/HC/PP/PVDF		
Dimensions	a	b	c	d	e	a	b	c	Ø	a	b
Immersion length 27"	-	-	-	-	-	-	-	-	S/AL: 1 1/32" or 2". HC: 1 1/16".	28"	31"
Immersion length 39"	43 1/2"	46 1/2"	40"	14"	8"	43 1/2"	46 1/2"	40"	PP/PVDF: 1 1/16" or 2"	40"	42 1/2"
Immersion length 47"	51 1/2"	54 1/2"	48"	14"	8"	51 1/2"	54 1/2"	48"		47 1/2"	50 1/2"

For example: Type F 430 S-41/38 with an immersion length of 39" has a total length (shown as dimension „b“) of 42 1/2". The total length of the pump including motor type F 460 Ex is 42 1/2" + 11 1/2" = 54".

FLUX accessories & complements



It is not merely the pump that makes the FLUX solution a perfect equipment. FLUX Pump Kits include everything for that quick start required by today's busy engineers and buyers: a ready to work, straight out of the box pump. All component parts – pump, motor and accessories – are carefully selected to complement each other.

FLUX Pump Kits are available for:

- acids and alkalis
- concentrated acids and alkalis
- petroleum products
- highly flammable liquids
- universal applications
- 99,98 % drum emptying

Select the most suitable combination and see the advantages of buying a FLUX Pump Kit, the all-inclusive service!



If you want to keep your liquids under control, FLUX drum and container pumps can be completed by a Liquid Meter Type FMC 100. Various models are available in PP, ETFE or Stainless Steel for flowrates of 2,6 – 26 GAL /min. An easy-to-read 7-digit LCD unit together with multifunctional keys ensures a simple calibration and input, everything for easy use by the operator. All models are explosion-proof to II 2 G EEx ia IIB T6 according to ATEX-Directive 94/9/EC.

For detailed information on FLUX Pump Kits, FLUX Liquid Meters and other FLUX products please ask for our sales brochures. Just fill in the form on the following page and return it by fax.



YES!

I am interested in top class pump technology.
Please send the following catalogues:

- | | |
|---|--|
| <input type="checkbox"/> JUNIORFLUX for low volumes | <input type="checkbox"/> FLUX Air-operated Diaphragm Pumps |
| <input type="checkbox"/> FLUX Pump-Kits | <input type="checkbox"/> FLUX Mixers |
| <input type="checkbox"/> FLUX High Viscosity Liquid Pumps | <input type="checkbox"/> FLUX Liquid Meters |
| <input type="checkbox"/> FLUX Centrifugal Immersion Pumps | |

Name

Company

Address

Telephone

Fax

e-mail

Please mark with a cross, complete the address and then send us a fax. Fax number see on the back side!



Innovators in Flow Technology



All around the globe, FLUX is synonymous with top standards in pump technology. Whether it is drum pumps, high viscosity liquid pumps, vertical centrifugal immersion pumps, air-operated diaphragm pumps, liquid meters, mixers or top class accessories – FLUX with its complete and comprehensive range is always the one to address to. Benefit from our competence. We look forward to hearing from you!

FLUX PUMPS CORPORATION
4330 Commerce Circle, Atlanta, GA 30336
Phone: (404) 691-6010 · Fax (404) 691-6314
1-800-for-FLUX
www.flux-pumps.com

Distributed by